

DATA SHEET

For a complete data sheet, please also download:

- The IC06 74HC/HCT/HCU/HCMOS Logic Family Specifications
- The IC06 74HC/HCT/HCU/HCMOS Logic Package Information
- The IC06 74HC/HCT/HCU/HCMOS Logic Package Outlines

74HC/HCT237

3-to-8 line decoder/demultiplexer
with address latches

Product specification
File under Integrated Circuits, IC06

December 1990

3-to-8 line decoder/demultiplexer with address latches

74HC/HCT237

FEATURES

- Combines 3-to-8 decoder with 3-bit latch
- Multiple input enable for easy expansion or independent controls
- Active HIGH mutually exclusive outputs
- Output capability: standard
- I_{CC} category: MSI

GENERAL DESCRIPTION

The 74HC/HCT237 are high-speed Si-gate CMOS devices and are pin compatible with low power Schottky TTL (LSTTL). They are specified in compliance with JEDEC standard no. 7A.

The 74HC/HCT237 are 3-to-8 line decoder/demultiplexers with latches at the three address inputs (A_n). The "237" essentially combines the 3-to-8 decoder function with a 3-bit storage latch. When the latch is enabled ($\overline{LE} = \text{LOW}$), the "237" acts as a 3-to-8 active LOW decoder. When the latch enable (\overline{LE}) goes from LOW-to-HIGH, the last data present at the inputs before this transition, is stored in the latches. Further address changes are ignored as long as \overline{LE} remains HIGH.

The output enable input (\overline{E}_1 and E_2) controls the state of the outputs independent of the address inputs or latch operation. All outputs are HIGH unless \overline{E}_1 is LOW and E_2 is HIGH.

The "237" is ideally suited for implementing non-overlapping decoders in 3-state systems and strobed (stored address) applications in bus oriented systems.

QUICK REFERENCE DATA

GND = 0 V; $T_{amb} = 25\text{ }^\circ\text{C}$; $t_r = t_f = 6\text{ ns}$

SYMBOL	PARAMETER	CONDITIONS	TYPICAL		UNIT
			HC	HCT	
t_{PHL} / t_{PLH}	propagation delay	$C_L = 15\text{ pF}; V_{CC} = 5\text{ V}$			
	A_n to Y_n		16	19	ns
	\overline{LE} to Y_n		19	21	ns
	\overline{E}_1 to Y_n		14	17	ns
	E_2 to Y_n		14	17	ns
C_I	input capacitance		3.5	3.5	pF
C_{PD}	power dissipation capacitance per package	notes 1 and 2	60	63	pF

Notes

1. C_{PD} is used to determine the dynamic power dissipation (P_D in μW):

$$P_D = C_{PD} \times V_{CC}^2 \times f_i + \sum (C_L \times V_{CC}^2 \times f_o) \text{ where:}$$

f_i = input frequency in MHz

f_o = output frequency in MHz

$\sum (C_L \times V_{CC}^2 \times f_o)$ = sum of outputs

C_L = output load capacitance in pF

V_{CC} = supply voltage in V

2. For HC the condition is $V_I = \text{GND to } V_{CC}$
For HCT the condition is $V_I = \text{GND to } V_{CC} - 1.5\text{ V}$

ORDERING INFORMATION

See "74HC/HCT/HCU/HCMOS Logic Package Information".

3-to-8 line decoder/demultiplexer with address latches

74HC/HCT237

PIN DESCRIPTION

PIN NO.	SYMBOL	NAME AND FUNCTION
1, 2, 3	A ₀ to A ₂	data inputs
4	\overline{LE}	latch enable input (active LOW)
5	\overline{E}_1	data enable input (active LOW)
6	E ₂	data enable input (active HIGH)
8	GND	ground (0 V)
15, 14, 13, 12, 11, 10, 9, 7	Y ₀ to Y ₇	multiplexer outputs
16	V _{CC}	positive supply voltage

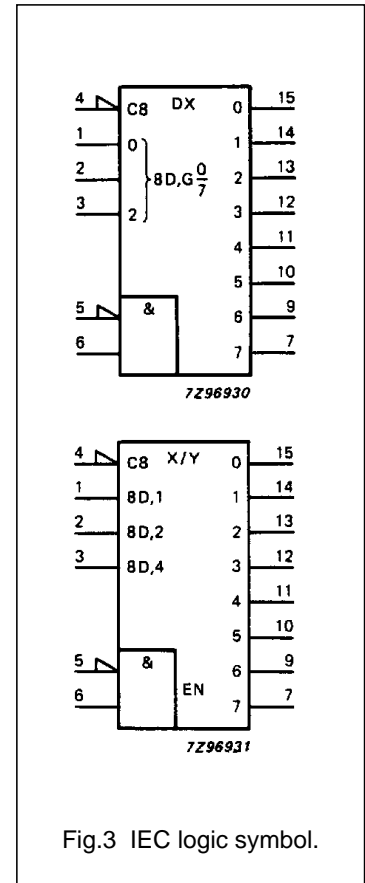
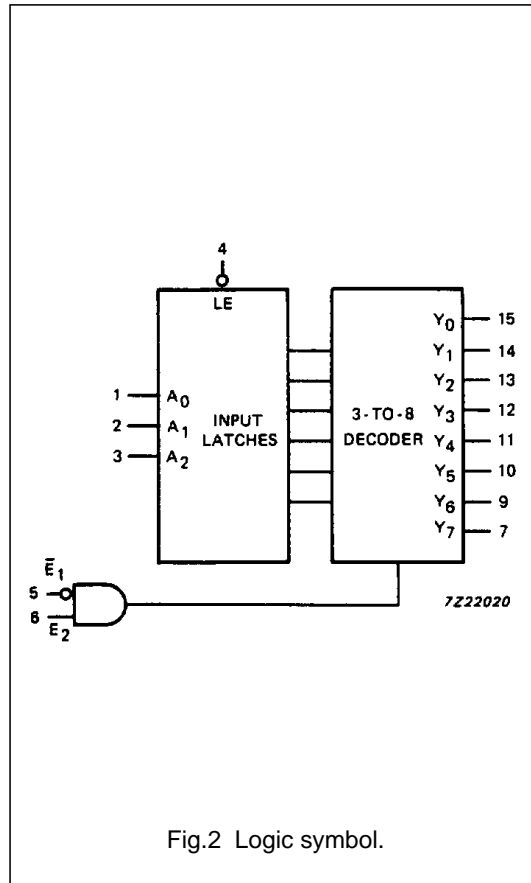
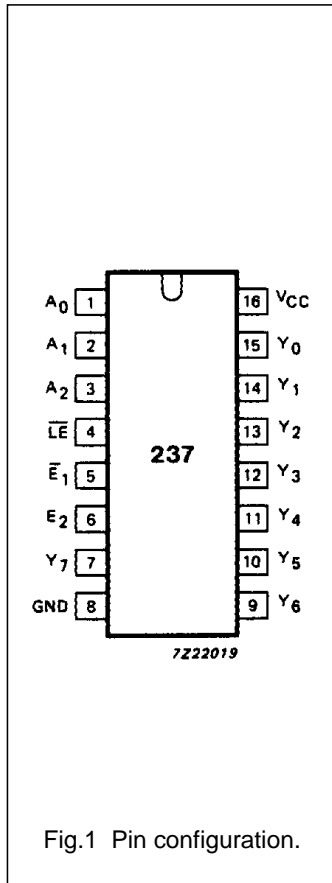

3-to-8 line decoder/demultiplexer with address latches

74HC/HCT237

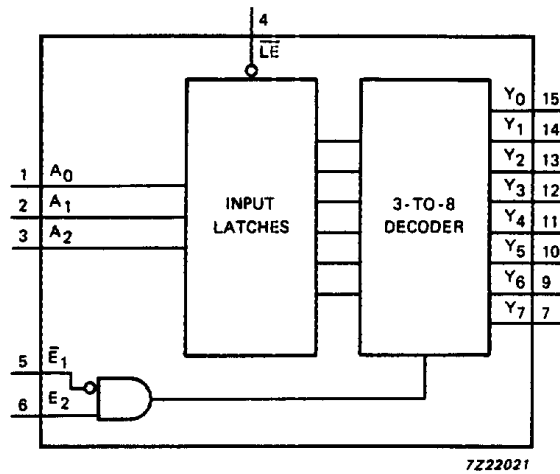

Fig.4 Functional diagram.

FUNCTION TABLE

INPUTS						OUTPUTS							
\overline{LE}	\overline{E}_1	E_2	A_0	A_1	A_2	Y_0	Y_1	Y_2	Y_3	Y_4	Y_5	Y_6	Y_7
H	L	H	X	X	X	stable							
X	H	X	X	X	X	L	L	L	L	L	L	L	L
X	X	L	X	X	X	L	L	L	L	L	L	L	L
L	L	H	L	L	L	H	L	L	L	L	L	L	L
L	L	H	H	L	L	L	H	L	L	L	L	L	L
L	L	H	L	H	L	L	L	H	L	L	L	L	L
L	L	H	H	H	L	L	L	L	H	L	L	L	L
L	L	H	L	L	H	L	L	L	L	H	L	L	L
L	L	H	H	L	H	L	L	L	L	L	H	L	L
L	L	H	L	H	H	L	L	L	L	L	L	H	L
L	L	H	H	H	H	L	L	L	L	L	L	L	H

Notes

- 1. H = HIGH voltage level
- L = LOW voltage level
- X = don't care

3-to-8 line decoder/demultiplexer with address latches

74HC/HCT237

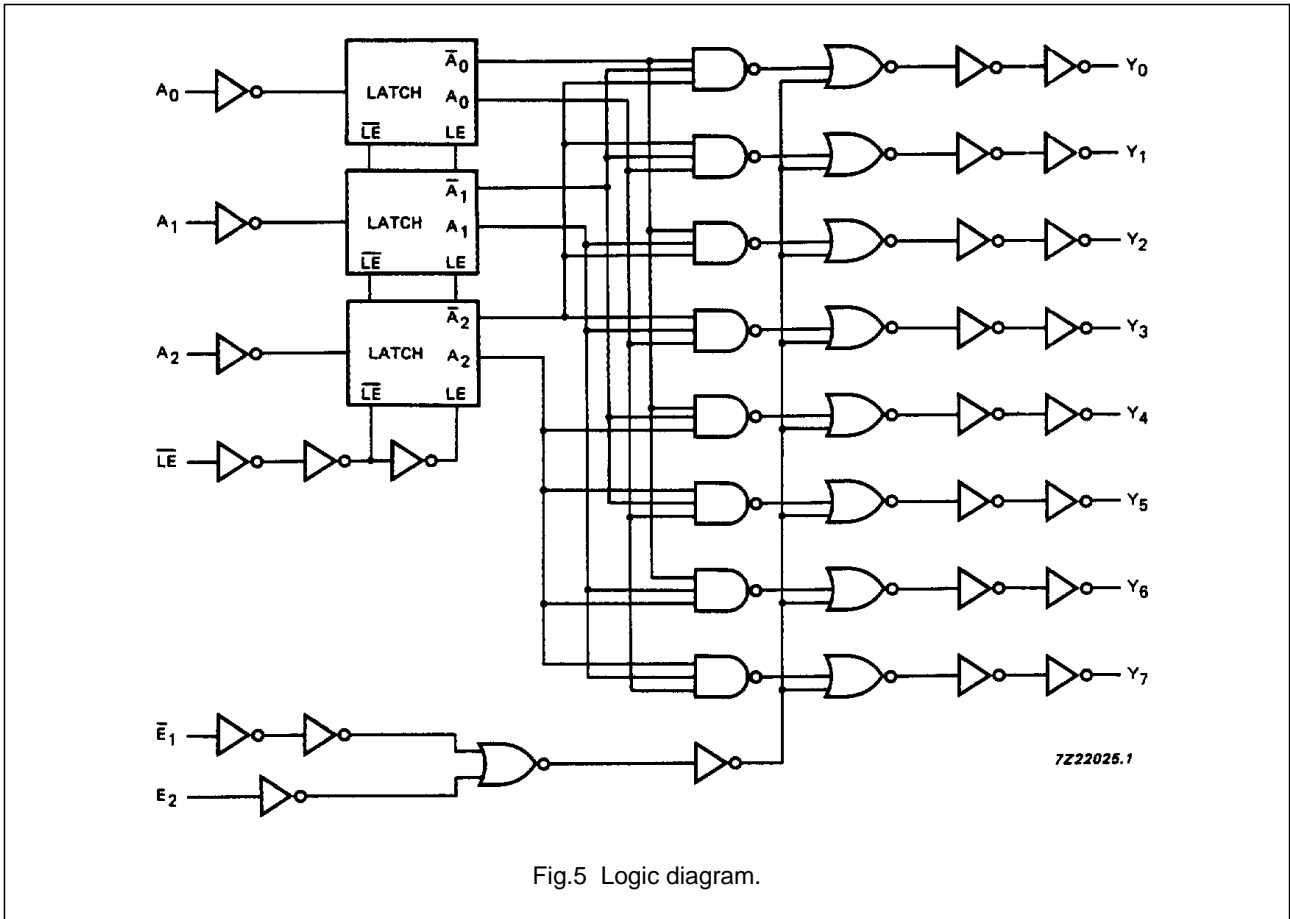

3-to-8 line decoder/demultiplexer with address latches

74HC/HCT237

DC CHARACTERISTICS FOR 74HC

For the DC characteristics see *"74HC/HCT/HCU/HCMOS Logic Family Specifications"*.

Output capability: standard

I_{CC} category: MSI

AC CHARACTERISTICS FOR 74HC

GND = 0 V; t_r = t_f = 6 ns; C_L = 50 pF

SYMBOL	PARAMETER	T _{amb} (°C)							UNIT	TEST CONDITIONS	
		74HC								V _{CC} (V)	WAVEFORMS
		+25			-40 to +85		-40 to +125				
		min.	typ.	max.	min.	max.	min.	max.			
t _{PHL} / t _{PLH}	propagation delay A _n to Y _n		52 19 15	160 32 27		200 40 34		240 48 41	ns	2.0 4.5 6.0	Fig.6
t _{PHL} / t _{PLH}	propagation delay $\overline{\text{LE}}$ to Y _n		61 22 18	190 38 32		240 48 41		285 57 48	ns	2.0 4.5 6.0	Fig.7
t _{PHL} / t _{PLH}	propagation delay $\overline{\text{E}}_1$ to Y _n		47 17 14	145 29 25		180 36 31		220 44 38	ns	2.0 4.5 6.0	Fig.7
t _{PHL} / t _{PLH}	propagation delay E ₂ to Y _n		47 17 14	145 29 25		180 36 31		220 44 38	ns	2.0 4.5 6.0	Fig.6
t _{THL} / t _{TLH}	output transition time		19 7 6	75 15 13		95 19 16		110 22 19	ns	2.0 4.5 6.0	Fig.6
t _w	$\overline{\text{LE}}$ pulse width LOW	50 10 9	11 4 3		65 13 11		75 15 13		ns	2.0 4.5 6.0	Fig.8
t _{su}	set-up time A _n to $\overline{\text{LE}}$	50 10 9	6 2 2		65 13 11		75 15 13		ns	2.0 4.5 6.0	Fig.8
t _h	hold time A _n to $\overline{\text{LE}}$	30 6 5	3 1 1		40 8 7		45 9 8		ns	2.0 4.5 6.0	Fig.8

3-to-8 line decoder/demultiplexer with address latches

74HC/HCT237

DC CHARACTERISTICS FOR 74HCT

For the DC characteristics see *"74HC/HCT/HCU/HCMOS Logic Family Specifications"*.

Output capability: standard

I_{CC} category: MSI

Note to HCT types

The value of additional quiescent supply current (ΔI_{CC}) for a unit load of 1 is given in the family specifications. To determine ΔI_{CC} per input, multiply this value by the unit load coefficient shown in the table below.

INPUT	UNIT LOAD COEFFICIENT
A _n	1.50
\overline{E}_1	1.50
E ₂	1.50
\overline{LE}	1.50

AC CHARACTERISTICS FOR 74HCT

GND = 0 V; t_r = t_f = 6 ns; C_L = 50 pF

SYMBOL	PARAMETER	T _{amb} (°C)							UNIT	TEST CONDITIONS	
		74HCT								V _{CC} (V)	WAVEFORMS
		+25			-40 to +85		-40 to +125				
		min.	typ.	max.	min.	max.	min.	max.			
t _{PHL} / t _{PLH}	propagation delay A _n to Y _n		22	38		48		57	ns	4.5	Fig.6
t _{PHL} / t _{PLH}	propagation delay \overline{LE} to Y _n		25	42		53		63	ns	4.5	Fig.7
t _{PHL} / t _{PLH}	propagation delay \overline{E}_1 to Y _n		20	35		44		53	ns	4.5	Fig.7
t _{PHL} / t _{PLH}	propagation delay E ₂ to Y _n		20	33		41		50	ns	4.5	Fig.6
t _{THL} / t _{TLH}	output transition time		7	15		19		22	ns	4.5	Fig.6
t _W	\overline{LE} pulse width HIGH	10	5		13		15		ns	4.5	Fig.8
t _{SU}	set-up time A _n to \overline{LE}	10	2		13		15		ns	4.5	Fig.8
t _H	hold time A _n to \overline{LE}	5	0		5		5		ns	4.5	Fig.8

3-to-8 line decoder/demultiplexer with address latches

74HC/HCT237

AC WAVEFORMS

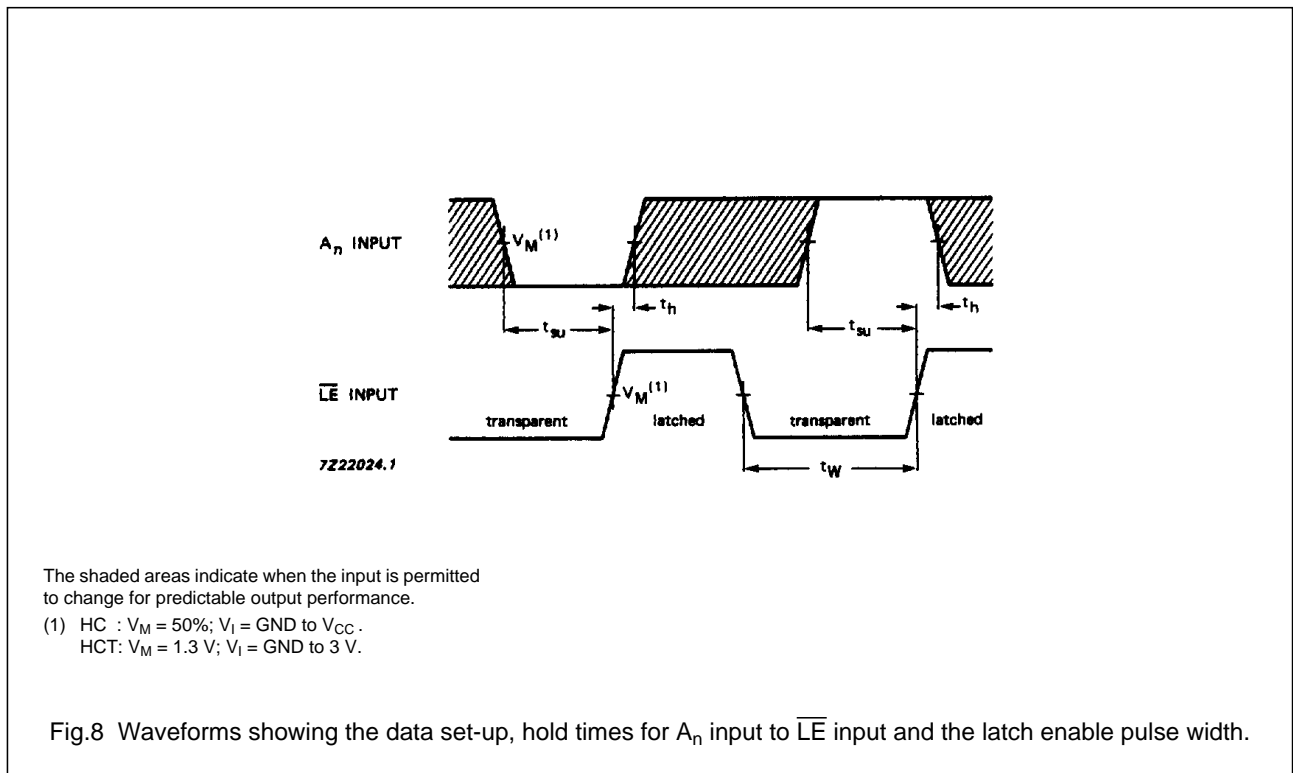
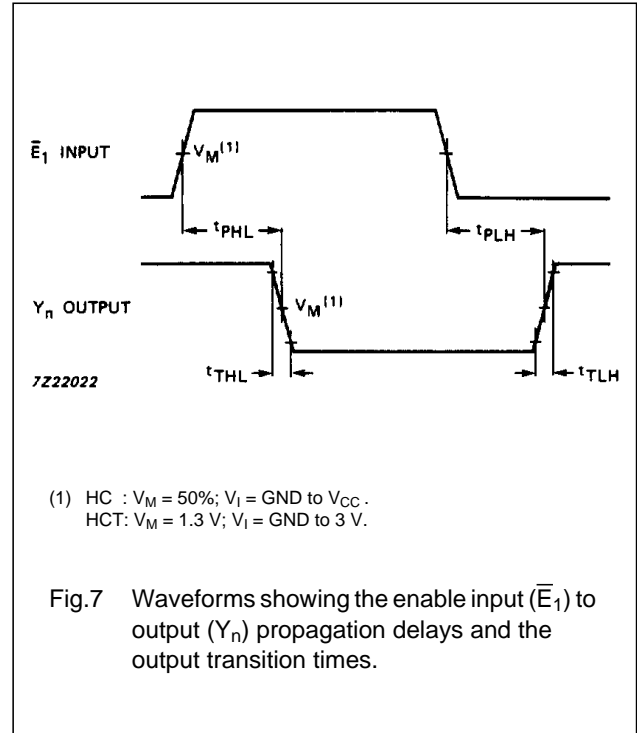
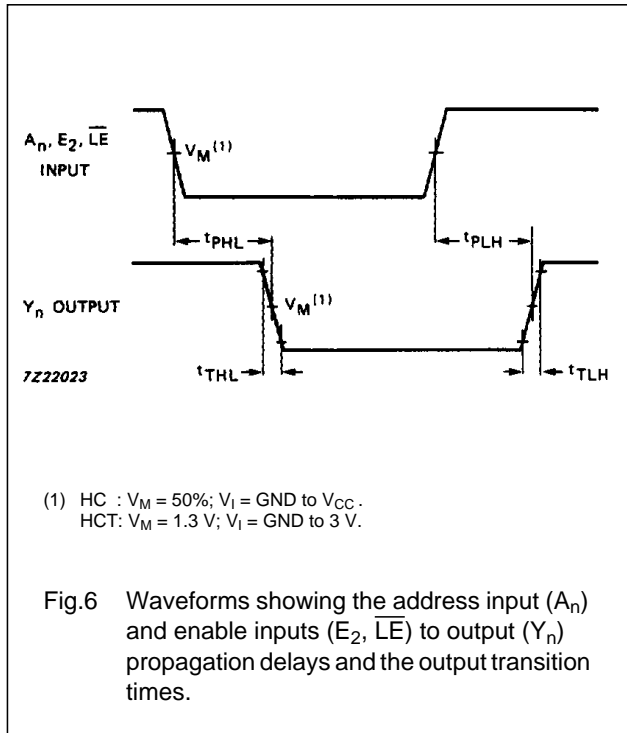

3-to-8 line decoder/demultiplexer with address latches

74HC/HCT237

APPLICATION INFORMATION

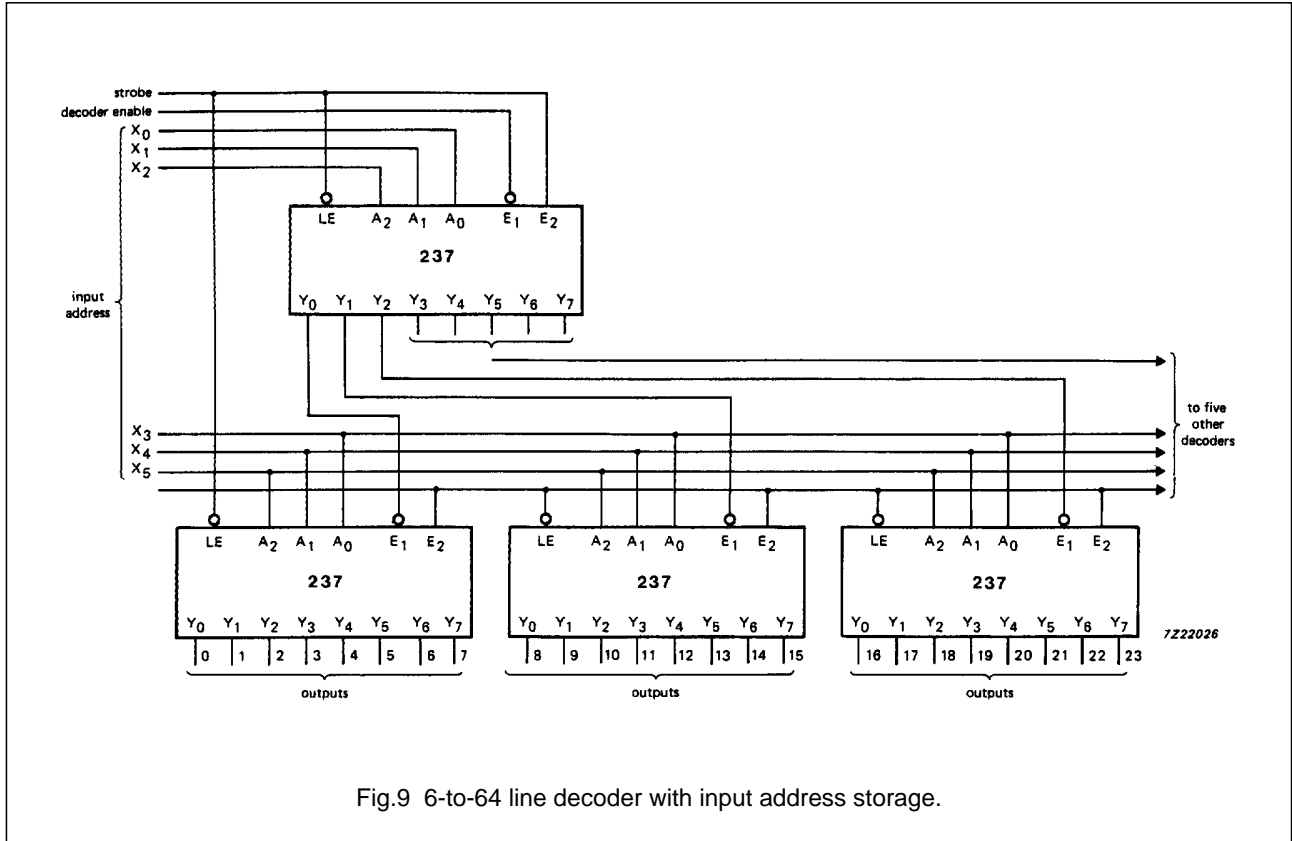

Fig.9 6-to-64 line decoder with input address storage.

PACKAGE OUTLINES

See "74HC/HCT/HCU/HCMOS Logic Package Outlines".