

# DATA SHEET

For a complete data sheet, please also download:

- The IC06 74HC/HCT/HCU/HCMOS Logic Family Specifications
- The IC06 74HC/HCT/HCU/HCMOS Logic Package Information
- The IC06 74HC/HCT/HCU/HCMOS Logic Package Outlines

## 74HC/HCT366

Hex buffer/line driver; 3-state;  
inverting

Product specification  
File under Integrated Circuits, IC06

December 1990

## Hex buffer/line driver; 3-state; inverting

## 74HC/HCT366

## FEATURES

- Inverting outputs
- Output capability: bus driver
- $I_{CC}$  category: MSI

The 74HC/HCT366 are hex inverting buffer/line drivers with 3-state outputs. The 3-state outputs ( $nY$ ) are controlled by the output enable inputs ( $\overline{OE}_1, \overline{OE}_2$ ).

A HIGH on  $\overline{OE}_n$  causes the outputs to assume a high impedance OFF-state.

The "366" is identical to the "365" but has inverting outputs.

## GENERAL DESCRIPTION

The 74HC/HCT366 are high-speed Si-gate CMOS devices and are pin compatible with low power Schottky TTL (LSTTL). They are specified in compliance with JEDEC standard no. 7A.

## QUICK REFERENCE DATA

GND = 0 V;  $T_{amb} = 25\text{ }^\circ\text{C}$ ;  $t_r = t_f = 6\text{ ns}$

SYMBOL	PARAMETER	CONDITIONS	TYPICAL		UNIT
			HC	HCT	
$t_{PHL}/t_{PLH}$	propagation delay nA to nY	$C_L = 15\text{ pF}$ ; $V_{CC} = 5\text{ V}$	10	11	ns
$C_I$	input capacitance		3.5	3.5	pF
$C_{PD}$	power dissipation capacitance per buffer	notes 1 and 2	30	30	pF

## Notes

1.  $C_{PD}$  is used to determine the dynamic power dissipation ( $P_D$  in  $\mu\text{W}$ ):

$$P_D = C_{PD} \times V_{CC}^2 \times f_i + \sum (C_L \times V_{CC}^2 \times f_o) \text{ where:}$$

$f_i$  = input frequency in MHz

$f_o$  = output frequency in MHz

$\sum (C_L \times V_{CC}^2 \times f_o)$  = sum of outputs

$C_L$  = output load capacitance in pF

$V_{CC}$  = supply voltage in V

2. For HC the condition is  $V_I = \text{GND to } V_{CC}$   
For HCT the condition is  $V_I = \text{GND to } V_{CC} - 1.5\text{ V}$

## ORDERING INFORMATION

See "74HC/HCT/HCU/HCMOS Logic Package Information".

Hex buffer/line driver; 3-state; inverting

74HC/HCT366

PIN DESCRIPTION

PIN NO.	SYMBOL	NAME AND FUNCTION
1, 15	$\overline{OE}_1, \overline{OE}_2$	output enable inputs (active LOW)
2, 4, 6, 10, 12, 14	1A to 6A	data inputs
3, 5, 7, 9, 11, 13	$1\overline{Y}$ to $6\overline{Y}$	data outputs
8	GND	ground (0 V)
16	V <sub>CC</sub>	positive supply voltage

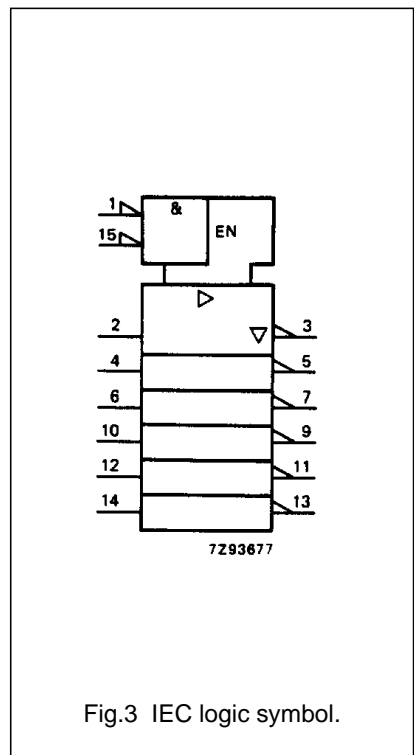
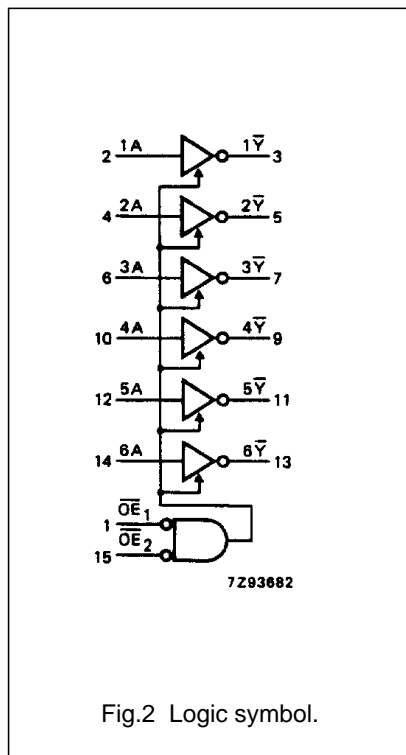
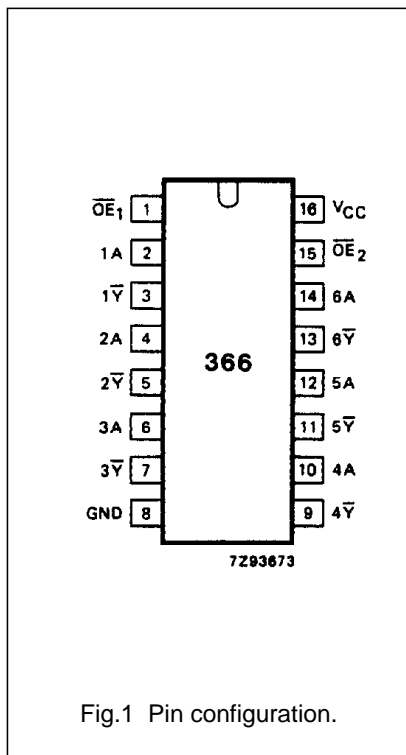

Hex buffer/line driver; 3-state; inverting

74HC/HCT366

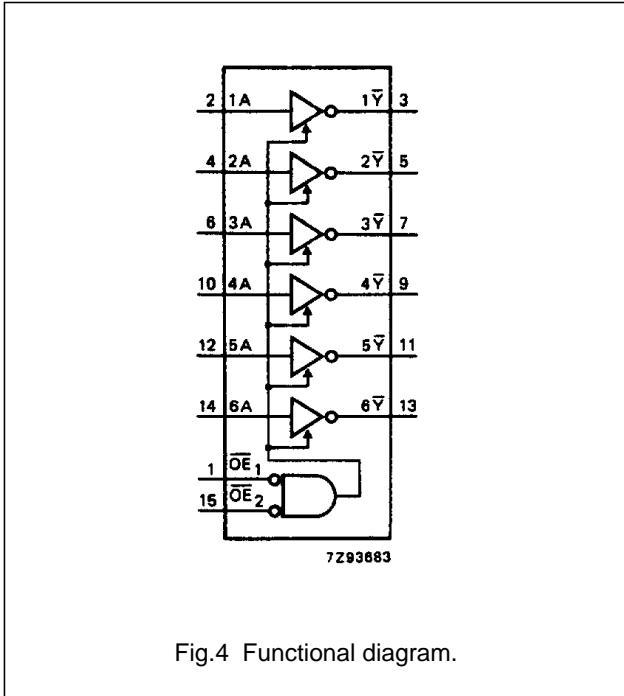

Fig.4 Functional diagram.

FUNCTION TABLE

INPUTS			OUTPUT
$\overline{OE}_1$	$\overline{OE}_2$	nA	n $\overline{Y}$
L	L	L	H
L	L	H	L
X	H	X	Z
H	X	X	Z

Notes

1. H = HIGH voltage level  
 L = LOW voltage level  
 X = don't care  
 Z = high impedance OFF-state

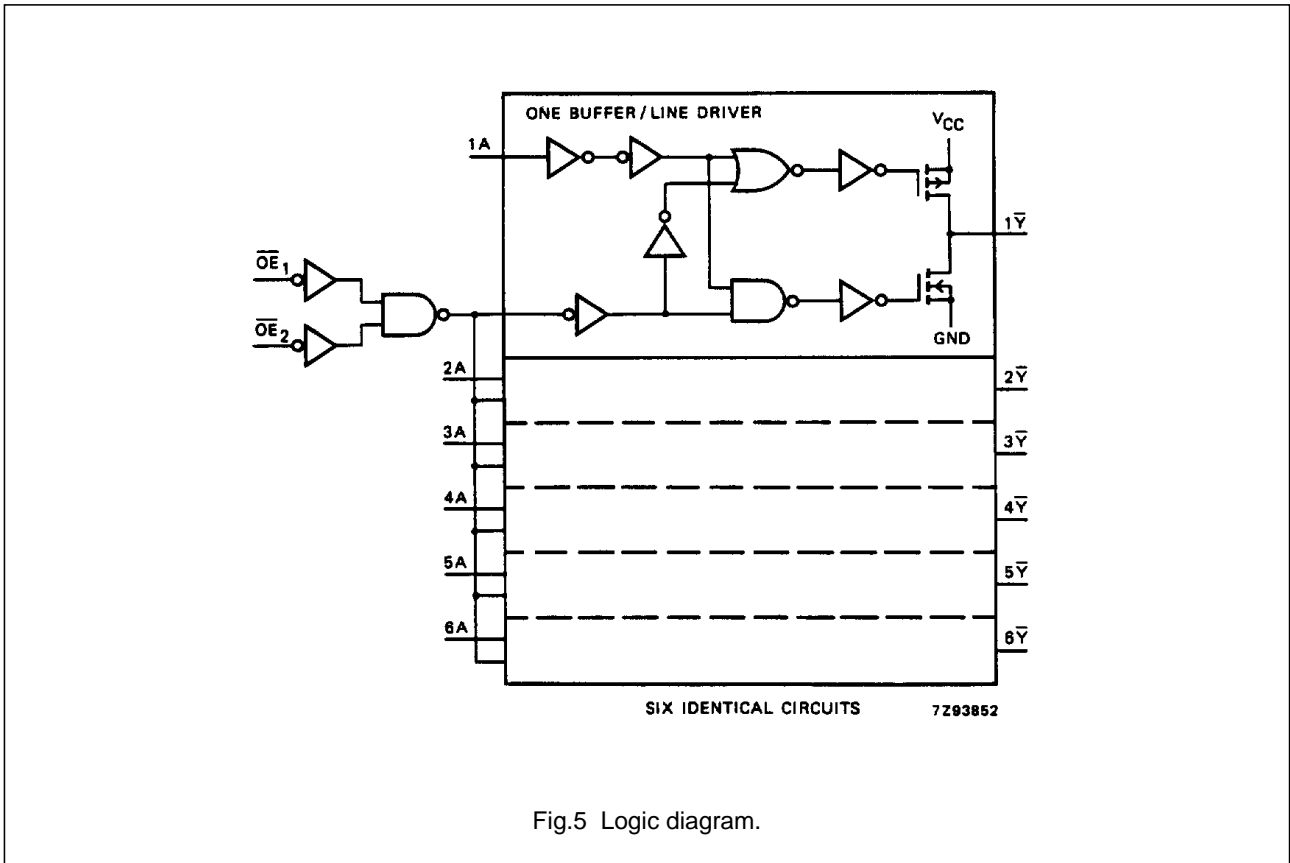

Fig.5 Logic diagram.

## Hex buffer/line driver; 3-state; inverting

## 74HC/HCT366

**DC CHARACTERISTICS FOR 74HC**

For the DC characteristics see *"74HC/HCT/HCU/HCMOS Logic Family Specifications"*.

Output capability: bus driver

I<sub>CC</sub> category: MSI

**AC CHARACTERISTICS FOR 74HC**

GND = 0 V; t<sub>r</sub> = t<sub>f</sub> = 6 ns; C<sub>L</sub> = 50 pF

SYMBOL	PARAMETER	T <sub>amb</sub> (°C)							UNIT	TEST CONDITIONS	
		74HC								V <sub>CC</sub> (V)	WAVEFORMS
		+25			-40 to +85		-40 to +125				
		min.	typ.	max.	min.	max.	min.	max.			
t <sub>PHL</sub> / t <sub>PLH</sub>	propagation delay nA to n $\bar{Y}$		33 12 10	100 20 17		125 25 21		150 30 26	ns	2.0 4.5 6.0	Fig.6
t <sub>PZH</sub> / t <sub>PZL</sub>	3-state output enable time $\overline{OE}_n$ to n $\bar{Y}$		44 16 13	150 30 26		190 38 33		225 45 38	ns	2.0 4.5 6.0	Fig.7
t <sub>PHZ</sub> / t <sub>PLZ</sub>	3-state output disable time $\overline{OE}_n$ to n $\bar{Y}$		55 20 16	150 30 26		190 38 33		225 45 38	ns	2.0 4.5 6.0	Fig.7
t <sub>THL</sub> / t <sub>TLH</sub>	output transition time		14 5 4	60 12 10		75 15 13		90 18 15	ns	2.0 4.5 6.0	Fig.6

## Hex buffer/line driver; 3-state; inverting

## 74HC/HCT366

**DC CHARACTERISTICS FOR 74HCT**

For the DC characteristics see *"74HC/HCT/HCU/HCMOS Logic Family Specifications"*.

Output capability: bus driver

I<sub>CC</sub> category: MSI

**Note to HCT types**

The value of additional quiescent supply current ( $\Delta I_{CC}$ ) for a unit load of 1 is given in the family specifications. To determine  $\Delta I_{CC}$  per input, multiply this value by the unit load coefficient shown in the table below.

INPUT	UNIT LOAD COEFFICIENT
$\overline{OE}_1$	1.00
$\overline{OE}_2$	0.90
nA	1.00

**AC CHARACTERISTICS FOR 74HCT**

GND = 0 V;  $t_r = t_f = 6$  ns;  $C_L = 50$  pF

SYMBOL	PARAMETER	T <sub>amb</sub> (°C)						UNIT	TEST CONDITIONS		
		74HCT							V <sub>CC</sub> (V)	WAVEFORMS	
		+25			-40 to +85		-40 to +125				
		min.	typ.	max.	min.	max.	min.				max.
t <sub>PHL</sub> / t <sub>PLH</sub>	propagation delay nA to n $\overline{Y}$		13	24		30		36	ns	4.5	Fig.6
t <sub>PZH</sub> / t <sub>PZL</sub>	3-state output enable time $\overline{OE}_n$ to n $\overline{Y}$		16	35		44		53	ns	4.5	Fig.7
t <sub>PHZ</sub> / t <sub>PLZ</sub>	3-state output disable time $\overline{OE}_n$ to n $\overline{Y}$		20	35		44		53	ns	4.5	Fig.7
t <sub>THL</sub> / t <sub>TLH</sub>	output transition time		5	12		15		18	ns	4.5	Fig.6

Hex buffer/line driver; 3-state; inverting

74HC/HCT366

AC WAVEFORMS

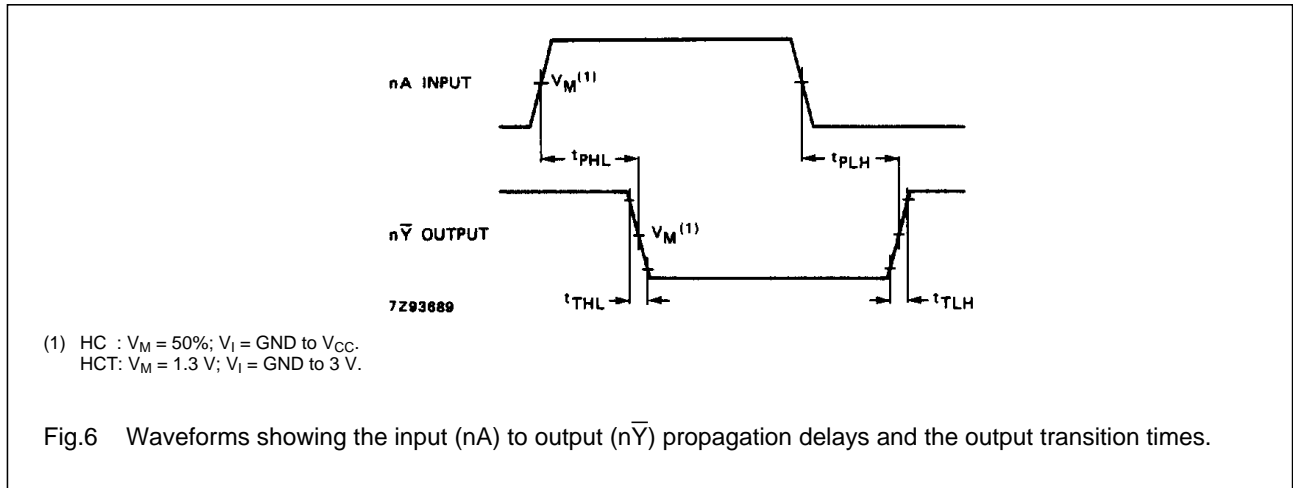

Fig.6 Waveforms showing the input (nA) to output (nY) propagation delays and the output transition times.

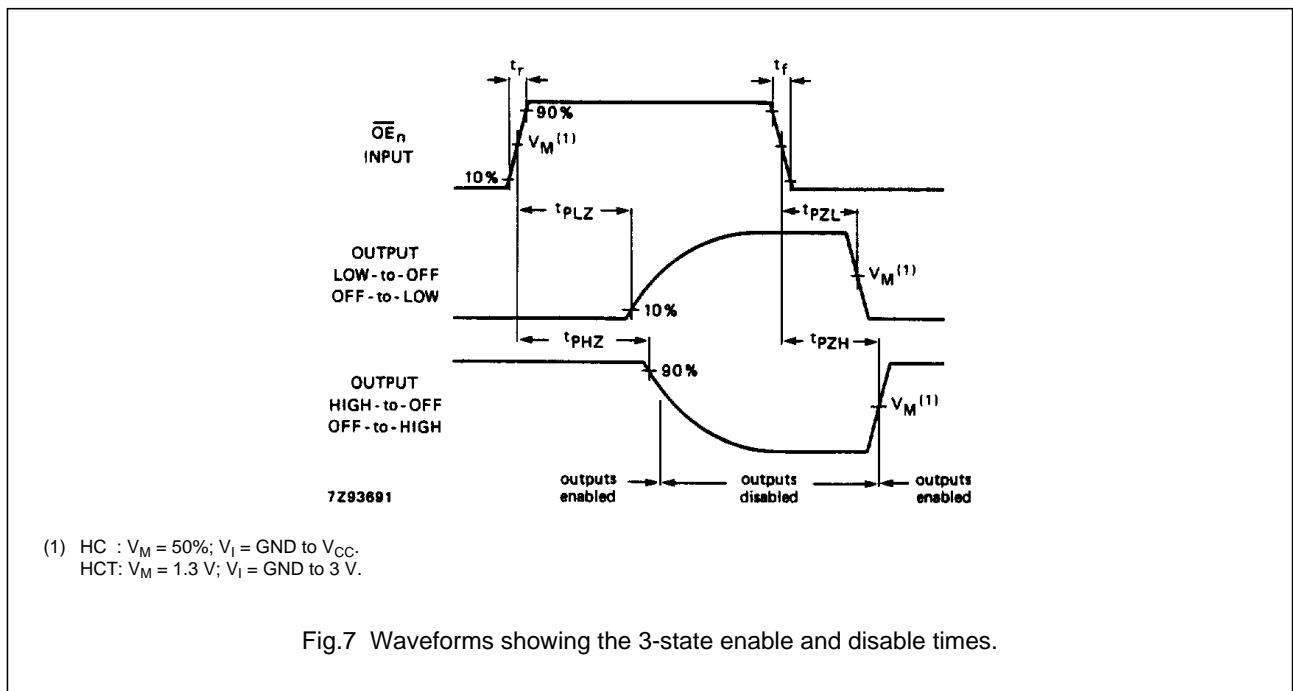

Fig.7 Waveforms showing the 3-state enable and disable times.

PACKAGE OUTLINES

See "74HC/HCT/HCU/HCMOS Logic Package Outlines".