

DATA SHEET

For a complete data sheet, please also download:

- The IC06 74HC/HCT/HCU/HCMOS Logic Family Specifications
- The IC06 74HC/HCT/HCU/HCMOS Logic Package Information
- The IC06 74HC/HCT/HCU/HCMOS Logic Package Outlines

74HC/HCT4052 Dual 4-channel analog multiplexer/demultiplexer

Product specification
File under Integrated Circuits, IC06

December 1990

Dual 4-channel analog multiplexer/demultiplexer

74HC/HCT4052

FEATURES

- Wide analog input voltage range: ± 5 V.
- Low "ON" resistance:
80 Ω (typ.) at $V_{CC} - V_{EE} = 4.5$ V
70 Ω (typ.) at $V_{CC} - V_{EE} = 6.0$ V
60 Ω (typ.) at $V_{CC} - V_{EE} = 9.0$ V
- Logic level translation:
to enable 5 V logic to communicate with ± 5 V analog signals
- Typical "break before make" built in
- Output capability: non-standard
- I_{CC} category: MSI

GENERAL DESCRIPTION

The 74HC/HCT4052 are high-speed Si-gate CMOS devices and are pin compatible with the "4052" of the "4000B" series. They are specified in compliance with JEDEC standard no. 7A.

QUICK REFERENCE DATA

$V_{EE} = GND = 0$ V; $T_{amb} = 25$ °C; $t_r = t_f = 6$ ns

SYMBOL	PARAMETER	CONDITIONS	TYPICAL		UNIT
			HC	HCT	
t_{PZH}/t_{PZL}	turn "ON" time \bar{E} or S_n to V_{OS}	$C_L = 15$ pF; $R_L = 1$ k Ω ;	28	18	ns
t_{PHZ}/t_{PLZ}	turn "OFF" time \bar{E} or S_n to V_{OS}	$V_{CC} = 5$ V	21	13	ns
C_I	input capacitance		3.5	3.5	pF
C_{PD}	power dissipation capacitance per switch	notes 1 and 2	57	57	pF
C_S	max. switch capacitance independent (Y)		5	5	pF
	common (Z)		12	12	pF

Notes

1. C_{PD} is used to determine the dynamic power dissipation (P_D in μ W):

$$P_D = C_{PD} \times V_{CC}^2 \times f_i + \sum \{(C_L + C_S) \times V_{CC}^2 \times f_o\}$$
 where:

f_i = input frequency in MHz

f_o = output frequency in MHz

$\sum \{(C_L + C_S) \times V_{CC}^2 \times f_o\}$ = sum of outputs

C_L = output load capacitance in pF

C_S = max. switch capacitance in pF

V_{CC} = supply voltage in V

2. For HC the condition is $V_I = GND$ to V_{CC}
For HCT the condition is $V_I = GND$ to $V_{CC} - 1.5$ V

The 74HC/HCT4052 are dual 4-channel analog multiplexers/demultiplexers with common select logic. Each multiplexer has four independent inputs/outputs (nY_0 to nY_3) and a common input/output (nZ). The common channel select logics include two digital select inputs (S_0 and S_1) and an active LOW enable input (\bar{E}).

With \bar{E} LOW, one of the four switches is selected (low impedance ON-state) by S_0 and S_1 . With \bar{E} HIGH, all switches are in the high impedance OFF-state, independent of S_0 and S_1 .

V_{CC} and GND are the supply voltage pins for the digital control inputs (S_0 and S_1 , and \bar{E}). The V_{CC} to GND ranges are 2.0 to 10.0 V for HC and 4.5 to 5.5 V for HCT. The analog inputs/outputs (nY_0 to nY_3 , and nZ) can swing between V_{CC} as a positive limit and V_{EE} as a negative limit. $V_{CC} - V_{EE}$ may not exceed 10.0 V.

For operation as a digital multiplexer/demultiplexer, V_{EE} is connected to GND (typically ground).

Dual 4-channel analog
multiplexer/demultiplexer

74HC/HCT4052

ORDERING INFORMATION

See "74HC/HCT/HCU/HCMOS Logic Package Information".

PIN DESCRIPTION

PIN NO.	SYMBOL	NAME AND FUNCTION
1, 5, 2, 4	2Y ₀ to 2Y ₃	independent inputs/outputs
6	\bar{E}	enable input (active LOW)
7	V _{EE}	negative supply voltage
8	GND	ground (0 V)
10, 9	S ₀ , S ₁	select inputs
12, 14, 15, 11	1Y ₀ to 1Y ₃	independent inputs/outputs
13, 3	1Z, 2Z	common inputs/outputs
16	V _{CC}	positive supply voltage

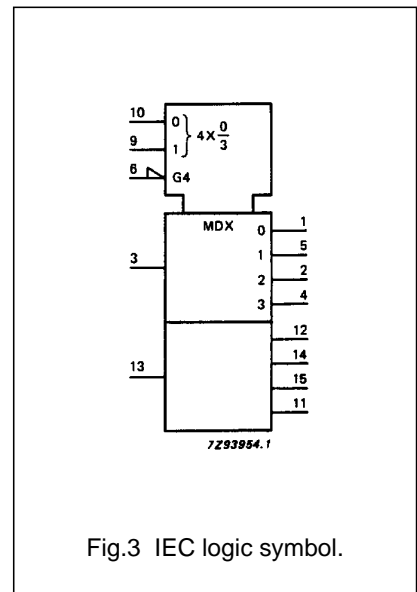
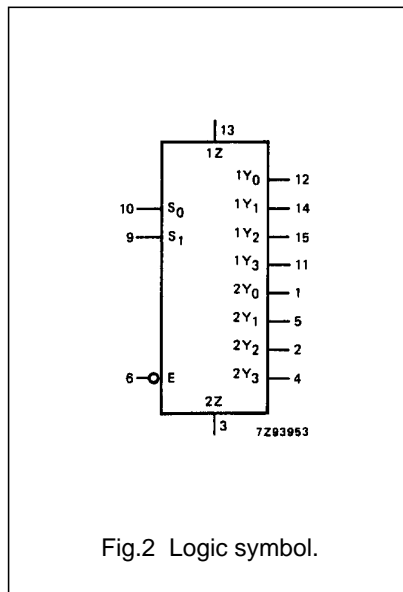
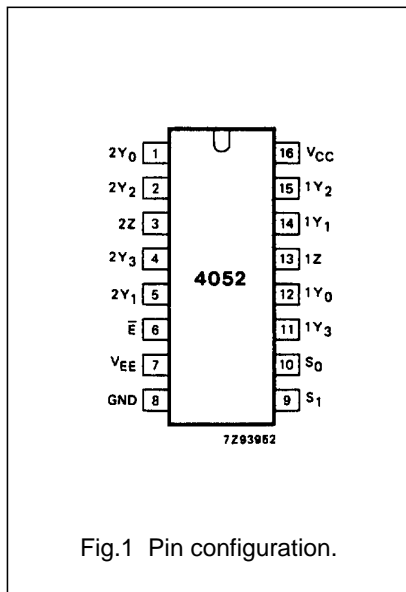

Dual 4-channel analog multiplexer/demultiplexer

74HC/HCT4052

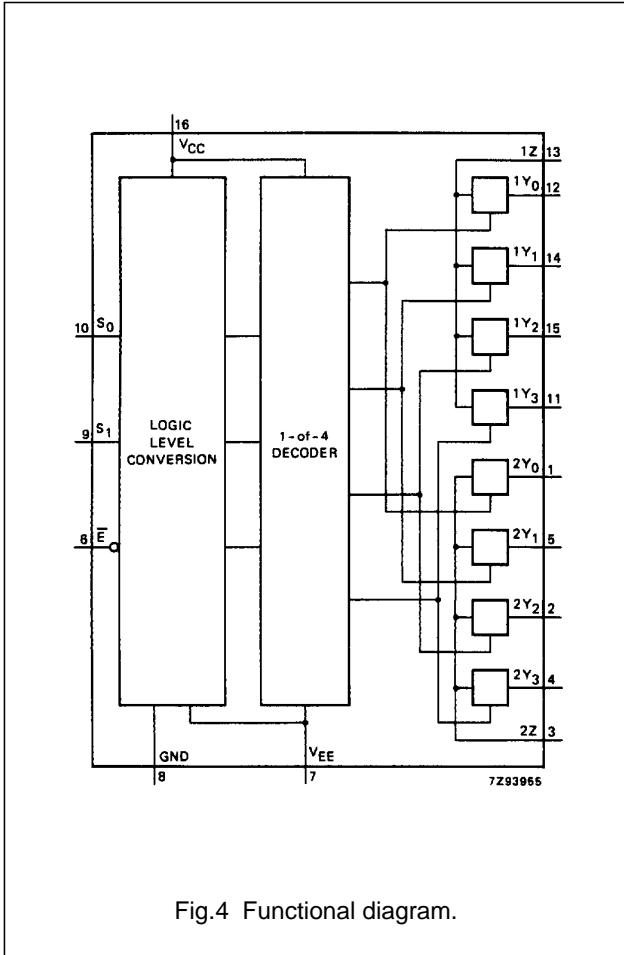

Fig.4 Functional diagram.

APPLICATIONS

- Analog multiplexing and demultiplexing
- Digital multiplexing and demultiplexing
- Signal gating

FUNCTION TABLE

INPUTS			CHANNEL ON
\bar{E}	S_1	S_0	
L	L	L	$nY_0 - nZ$
L	L	H	$nY_1 - nZ$
L	H	L	$nY_2 - nZ$
L	H	H	$nY_3 - nZ$
H	X	X	none

Notes

1. H = HIGH voltage level
L = LOW voltage level
X = don't care

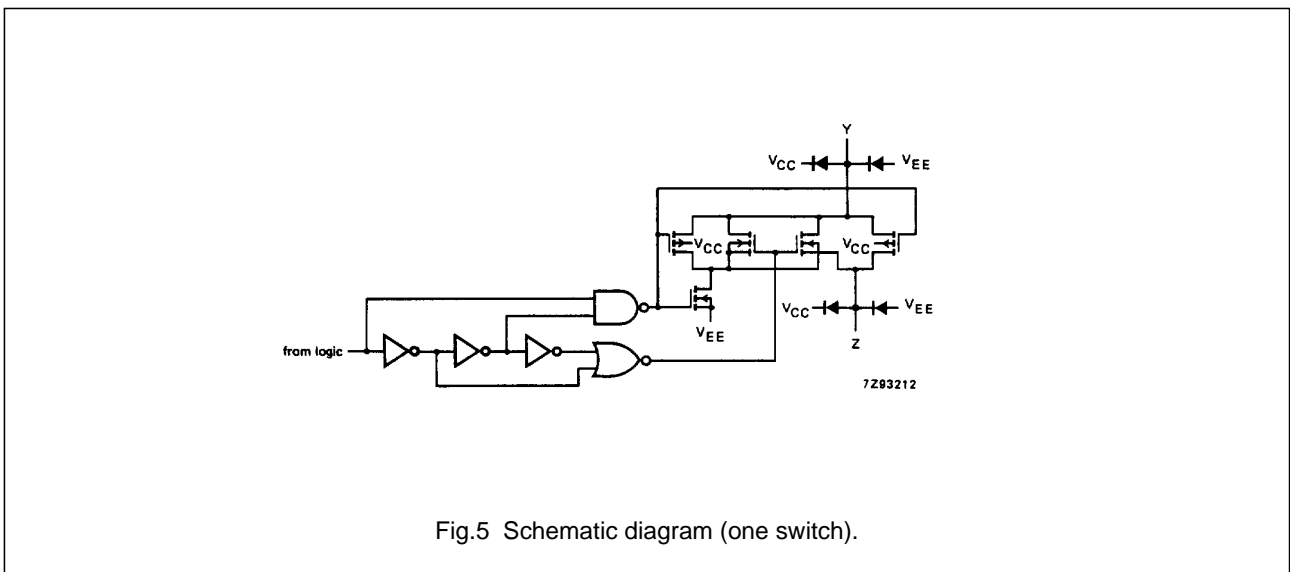

Fig.5 Schematic diagram (one switch).

Dual 4-channel analog multiplexer/demultiplexer

74HC/HCT4052

RATINGS

Limiting values in accordance with the Absolute Maximum System (IEC 134)

Voltages are referenced to $V_{EE} = \text{GND}$ (ground = 0 V)

SYMBOL	PARAMETER	MIN.	MAX.	UNIT	CONDITIONS
V_{CC}	DC supply voltage	-0.5	+11.0	V	
$\pm I_{IK}$	DC digital input diode current		20	mA	for $V_I < -0.5 \text{ V}$ or $V_I > V_{CC} + 0.5 \text{ V}$
$\pm I_{SK}$	DC switch diode current		20	mA	for $V_S < -0.5 \text{ V}$ or $V_S > V_{CC} + 0.5 \text{ V}$
$\pm I_S$	DC switch current		25	mA	for $-0.5 \text{ V} < V_S < V_{CC} + 0.5 \text{ V}$
$\pm I_{EE}$	DC V_{EE} current		20	mA	
$\pm I_{CC}; \pm I_{GND}$	DC V_{CC} or GND current		50	mA	
T_{stg}	storage temperature range	-65	+150	°C	
P_{tot}	power dissipation per package				for temperature range: -40 to +125 °C 74HC/HCT
	plastic DIL		750	mW	above +70 °C: derate linearly with 12 mW/K
	plastic mini-pack (SO)		500	mW	above +70 °C: derate linearly with 8 mW/K
P_S	power dissipation per switch		100	mW	

Note to ratings

- To avoid drawing V_{CC} current out of terminals nZ, when switch current flows in terminals nY_n, the voltage drop across the bidirectional switch must not exceed 0.4 V. If the switch current flows into terminals nZ, no V_{CC} current will flow out of terminals nY_n. In this case there is no limit for the voltage drop across the switch, but the voltages at nY_n and nZ may not exceed V_{CC} or V_{EE} .

RECOMMENDED OPERATING CONDITIONS

SYMBOL	PARAMETER	74HC			74HCT			UNIT	CONDITIONS
		min.	typ.	max.	min.	typ.	max.		
V_{CC}	DC supply voltage $V_{CC}-\text{GND}$	2.0	5.0	10.0	4.5	5.0	5.5	V	see Fig.6 and Fig.7
V_{CC}	DC supply voltage $V_{CC}-V_{EE}$	2.0	5.0	10.0	2.0	5.0	10.0	V	see Fig.6 and Fig.7
V_I	DC input voltage range	GND		V_{CC}	GND		V_{CC}	V	
V_S	DC switch voltage range	V_{EE}		V_{CC}	V_{EE}		V_{CC}	V	
T_{amb}	operating ambient temperature range	-40		+85	-40		+85	°C	see DC and AC CHARACTERISTICS
T_{amb}	operating ambient temperature range	-40		+125	-40		+125	°C	
t_r, t_f	input rise and fall times		6.0	1000 500 400 250		6.0	500	ns	$V_{CC} = 2.0 \text{ V}$ $V_{CC} = 4.5 \text{ V}$ $V_{CC} = 6.0 \text{ V}$ $V_{CC} = 10.0 \text{ V}$

Dual 4-channel analog
multiplexer/demultiplexer

74HC/HCT4052

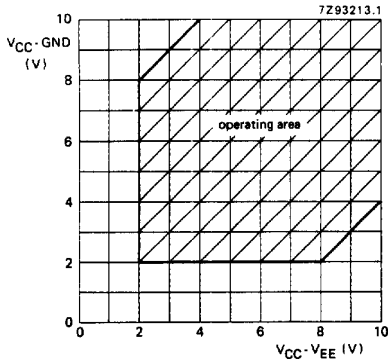

Fig.6 Guaranteed operating area as a function of the supply voltages for 74HC4052.

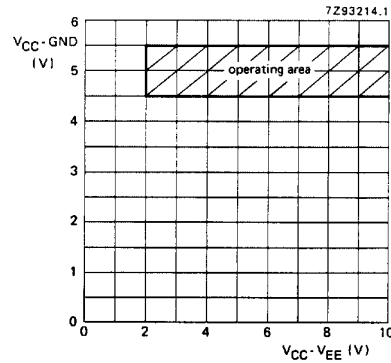

Fig.7 Guaranteed operating area as a function of the supply voltages for 74HCT4052.

DC CHARACTERISTICS FOR 74HC/HCT

For 74HC: $V_{CC} - GND$ or $V_{CC} - V_{EE} = 2.0, 4.5, 6.0$ and 9.0 V

For 74HCT: $V_{CC} - GND = 4.5$ and 5.5 V; $V_{CC} - V_{EE} = 2.0, 4.5, 6.0$ and 9.0 V

SYMBOL	PARAMETER	T_{amb} (°C)								UNIT	TEST CONDITIONS				
		74HC/HCT									V_{CC} (V)	V_{EE} (V)	I_S (μA)	V_{is}	V_I
		+25			-40 to +85		-40 to +125								
		min.	typ.	max.	min.	max.	min.	max.							
R_{ON}	ON resistance (peak)		-	-		-		-	Ω	2.0	0	100	V_{CC} to V_{EE}	V_{IH} or V_{IL}	
			100	180		225		270	Ω	4.5	0	1000			
			90	160		200		240	Ω	6.0	0	1000			
			70	130		165		195	Ω	4.5	-4.5	1000			
R_{ON}	ON resistance (rail)		150	-		-		-	Ω	2.0	0	100	V_{EE}	V_{IH} or V_{IL}	
			80	140		175		210	Ω	4.5	0	1000			
			70	120		150		180	Ω	6.0	0	1000			
			60	105		130		160	Ω	4.5	-4.5	1000			
R_{ON}	ON resistance (rail)		150	-		-		-	Ω	2.0	0	100	V_{CC}	V_{IH} or V_{IL}	
			90	160		200		240	Ω	4.5	0	1000			
			80	140		175		210	Ω	6.0	0	1000			
			65	120		150		180	Ω	4.5	-4.5	1000			
ΔR_{ON}	maximum ΔON resistance between any two channels		-						Ω	2.0	0		V_{CC} to V_{EE}	V_H or V_{IL}	
			9						Ω	4.5	0				
			8						Ω	6.0	0				
			6						Ω	4.5	-4.5				

Notes to the characteristics

- At supply voltages ($V_{CC} - V_{EE}$) approaching 2.0 V the Analog switch ON-resistance becomes extremely non-linear. There it is recommended that these devices be used to transmit digital signals only, when using these supply voltages
- For test circuit measuring R_{ON} see Fig.8

Dual 4-channel analog
multiplexer/demultiplexer

74HC/HCT4052

DC CHARACTERISTICS FOR 74HC

Voltages are referenced to GND (ground = 0 V)

SYMBOL	PARAMETER	T _{amb} (°C)						UNIT	TEST CONDITIONS				
		74HC							V _{CC} (V)	V _{EE} (V)	V _I	OTHER	
		+25			-40 to +85		-40 to +125						
		min.	typ.	max.	min.	max.	min.						max.
V _{IH}	HIGH level input voltage	1.5 3.15 4.2 6.3	1.2 2.4 3.2 4.7		1.5 3.15 4.2 6.3		1.5 3.15 4.2 6.3	V	2.0 4.5 6.0 9.0				
V _{IL}	LOW level input voltage		0.8 2.1 2.8 4.3	0.5 1.35 1.8 2.7		0.5 1.35 1.8 2.7		0.5 1.35 1.8 2.7	V	2.0 4.5 6.0 9.0			
±I _I	input leakage current			0.1 0.2		1.0 2.0		1.0 2.0	μA	6.0 10.0	0 0	V _{CC} or GND	
±I _S	analog switch OFF-state current per channel			0.1		1.0		1.0	μA	10.0	0	V _{IH} or V _{IL}	V _S = V _{CC} - V _{EE} (see Fig.10)
±I _S	analog switch OFF-state current all channels			0.2		2.0		2.0	μA	10.0	0	V _{IH} or V _{IL}	V _S = V _{CC} - V _{EE} (see Fig.10)
±I _S	analog switch ON-state current			0.2		2.0		2.0	μA	10.0	0	V _{IH} or V _{IL}	V _S = V _{CC} - V _{EE} (see Fig.11)
I _{CC}	quiescent supply current			8.0 16.0		80.0 160.0		160 320.0	μA	6.0 10.0	0 0	V _{CC} or GND	V _{IS} = V _{EE} or V _{CC} ; V _{OS} = V _{CC} or V _{EE}

Dual 4-channel analog multiplexer/demultiplexer

74HC/HCT4052

AC CHARACTERISTICS FOR 74HCGND = 0 V; $t_r = t_f = 6$ ns; $C_L = 50$ pF

SYMBOL	PARAMETER	T_{amb} (°C)						UNIT	TEST CONDITIONS			
		74HC							V_{CC} (V)	V_{EE} (V)	OTHER	
		+25			-40 to +85		-40 to +125					
		min.	typ.	max.	min.	max.	min.		max.			
t_{PHL}/t_{PLH}	propagation delay V_{is} to V_{os}		14 5 4 4	60 12 10 8		75 15 13 10		90 18 15 12	ns	2.0 4.5 6.0 4.5	0 0 0 -4.5	$R_L = \infty$; $C_L = 50$ pF (see Fig.18)
t_{PZH}/t_{PZL}	turn "ON" time \bar{E} to V_{os} S_n to V_{os}		105 38 30 26	325 65 55 46		405 81 69 58		490 98 83 69	ns	2.0 4.5 6.0 4.5	0 0 0 -4.5	$R_L = \infty$; $C_L = 50$ pF see Fig.19, 20 and 21
t_{PHZ}/t_{PLZ}	turn "OFF" time \bar{E} to V_{os} S_n to V_{os}		74 27 22 22	250 50 43 38		315 63 54 48		375 75 64 57	ns	2.0 4.5 6.0 4.5	0 0 0 -4.5	$R_L = 1$ k Ω ; $C_L = 50$ pF see Fig.19, 20 and 21

Dual 4-channel analog
multiplexer/demultiplexer

74HC/HCT4052

DC CHARACTERISTICS FOR 74HCT

Voltages are referenced to GND (ground = 0)

SYMBOL	PARAMETER	T _{amb} (°C)							UNIT	TEST CONDITIONS			
		74HCT								V _{CC} (V)	V _{EE} (V)	V _I	OTHER
		+25			-40 to +85		-40 to +125						
		min.	typ.	max.	min.	max.	min.	max.					
V _{IH}	HIGH level input voltage	2.0	1.6		2.0		2.0		V	4.5 to 5.5			
V _{IL}	LOW level input voltage		1.2	0.8		0.8		0.8	V	4.5 to 5.5			
±I _I	input leakage current			0.1		1.0		1.0	µA	5.5	0	V _{CC} or GND	
±I _S	analog switch OFF-state current per channel			0.1		1.0		1.0	µA	10.0	0	V _{IH} or V _{IL}	M _S = V _{CC} - V _{EE} (see Fig.10)
±I _S	analog switch OFF-state current all channels			0.2		2.0		2.0	µA	10.0	0	V _{IH} or V _{IL}	M _S = V _{CC} - V _{EE} (see Fig.10)
±I _S	analog switch ON-state current			0.2		2.0		2.0	µA	10.0	0	V _{IH} or V _{IL}	M _S = V _{CC} - V _{EE} (see Fig.11)
I _{CC}	quiescent supply current			8.0 16.0		80.0 160.0		160.0 320.0	µA	5.5 5.0	0 -5.0	V _{CC} or GND	V _{IS} = V _{EE} or V _{CC} ; V _{OS} = V _{CC} or V _{EE}
ΔI _{CC}	additional quiescent supply current per input pin for unit load coefficient is 1 (note 1)		100	360		450		490	µA	4.5 to 5.5	0	V _{CC} -2.1 V	other inputs at V _{CC} or GND

Note to HCT types

- The value of additional quiescent supply current (ΔI_{CC}) for a unit load of 1 is given here. To determine ΔI_{CC} per input, multiply this value by the unit load coefficient shown in the table below.

INPUT	UNIT LOAD COEFFICIENT
S _n	0.45
E	0.45

Dual 4-channel analog multiplexer/demultiplexer

74HC/HCT4052

AC CHARACTERISTICS FOR 74HCT

GND = 0 V; $t_r = t_f = 6$ ns; $C_L = 50$ pF

SYMBOL	PARAMETER	T_{amb} (°C)								UNIT	TEST CONDITIONS		
		74HCT									V_{CC} (V)	V_{EE} (V)	OTHER
		+25			-40 to +85		-40 to +125						
		min.	typ.	max.	min.	max.	min.	max.					
t_{PHL}/t_{PLH}	propagation delay V_{is} to V_{os}		5 4	12 8		15 10		18 12	ns	4.5 4.5	0 -4.5	$R_L = \infty$; $C_L = 50$ pF (see Fig.18)	
t_{PZH}/t_{PZL}	turn "ON" time \bar{E} to V_{os} S_n to V_{os}		41 28	70 48		88 60		105 72	ns	4.5 4.5	0 -4.5	$R_L = 1$ k Ω ; $C_L = 50$ pF see (Fig.19, 20 and 21)	
t_{PHZ}/t_{PLZ}	turn "OFF" time \bar{E} to V_{os} S_n to V_{os}		26 21	50 38		63 48		75 57	ns	4.5 4.5	0 -4.5	$R_L = 1$ k Ω ; $C_L = 50$ pF (Fig.19, 20 and 21)	

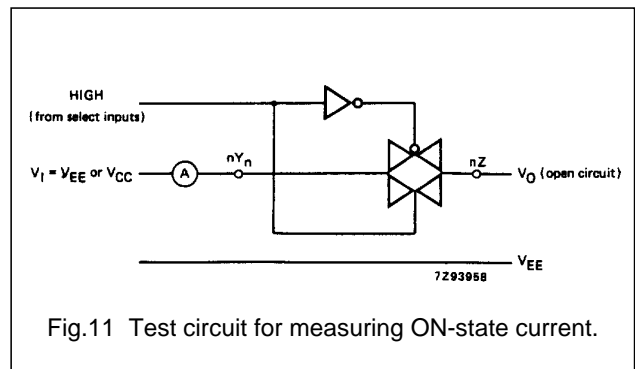
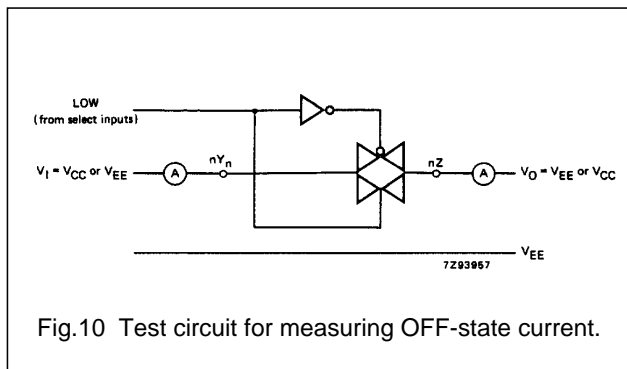
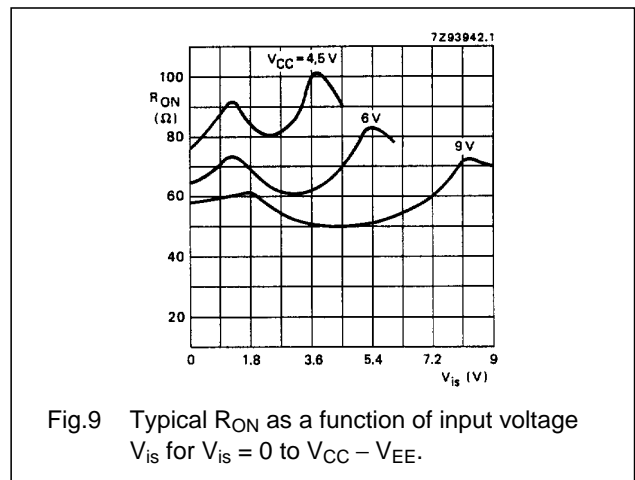
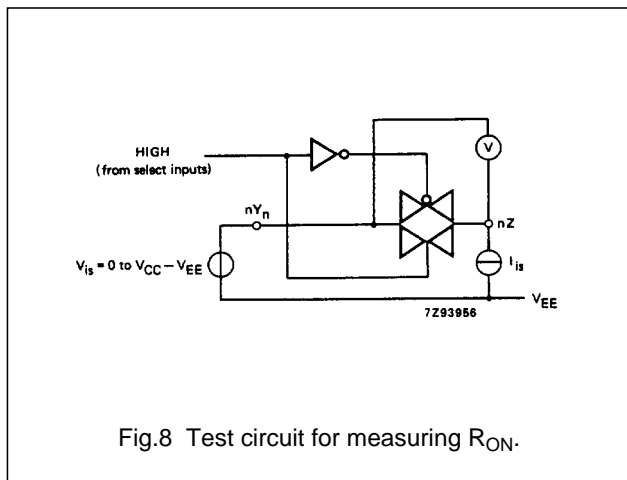

Dual 4-channel analog multiplexer/demultiplexer

74HC/HCT4052

ADDITIONAL AC CHARACTERISTICS FOR 74HC/HCT

Recommended conditions and typical values

GND = 0 V; $T_{amb} = 25\text{ }^{\circ}\text{C}$

SYMBOL	PARAMETER	typ.	UNIT	V_{CC} (V)	V_{EE} (V)	$V_{is(p-p)}$ (V)	CONDITIONS
	sine-wave distortion f = 1 kHz	0.04 0.02	% %	2.25 4.5	-2.25 -4.5	4.0 8.0	$R_L = 10\text{ k}\Omega$; $C_L = 50\text{ pF}$ (see Fig.14)
	sine-wave distortion f = 10 kHz	0.12 0.06	% %	2.25 4.5	-2.25 -4.5	4.0 8.0	$R_L = 10\text{ k}\Omega$; $C_L = 50\text{ pF}$ (see Fig.14)
	switch "OFF" signal feed-through	-50 -50	dB dB	2.25 4.5	-2.25 -4.5	note 1	$R_L = 600\text{ }\Omega$; $C_L = 50\text{ pF}$; f = 1 MHz see (Fig.12 and Fig.15)
	crosstalk between any two switches/ multiplexers	-60 -60	dB dB	2.25 4.5	-2.25 -4.5	note 1	$R_L = 600\text{ }\Omega$; $C_L = 50\text{ pF}$; f = 1 MHz (see Fig.16)
$V_{(p-p)}$	crosstalk voltage between control and any switch (peak-to-peak value)	110 220	mV mV	4.5 4.5	0 -4.5		$R_L = 600\text{ }\Omega$; $C_L = 50\text{ pF}$; f = 1 MHz (\bar{E} or S_n , square-wave between V_{CC} and GND, $t_r = t_f = 6\text{ ns}$) (see Fig.17)
f_{max}	minimum frequency response (-3dB)	170 180	MHz MHz	2.25 4.5	-2.25 -4.5	note 2	$R_L = 50\text{ }\Omega$; $C_L = 50\text{ pF}$ see (Fig.13 and Fig.14)
C_S	maximum switch capacitance independent (Y) common (Z)	5 12	pF pF				

Notes to AC characteristics

- Adjust input voltage V_{is} to 0 dBm level (0 dBm = 1 mW into 600 Ω).
- Adjust input voltage V_{is} to 0 dBm level at V_{OS} for 1 MHz (0 dBm = 1 mW into 50 Ω).

General notes

V_{is} is the input voltage at an nY_n or nZ terminal, whichever is assigned as an input

V_{os} is the output voltage at an nY_n or nZ terminal, whichever is assigned as an output

Dual 4-channel analog multiplexer/demultiplexer

74HC/HCT4052

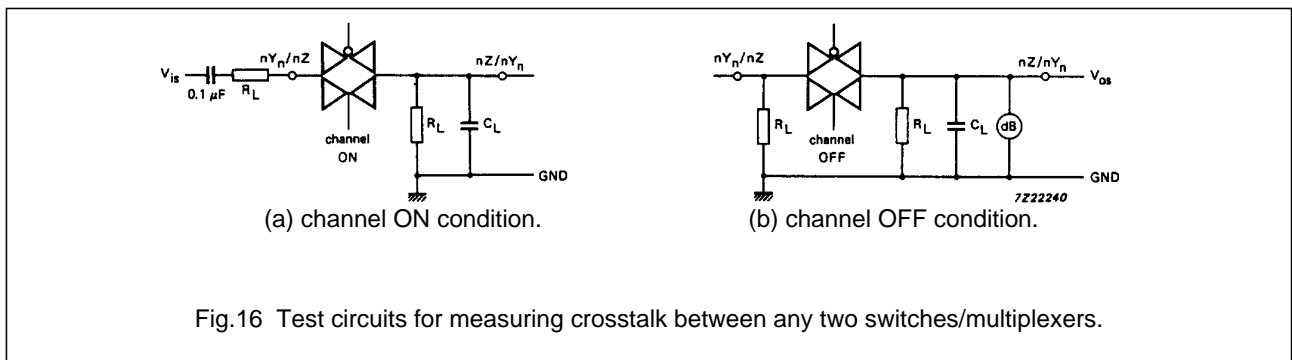
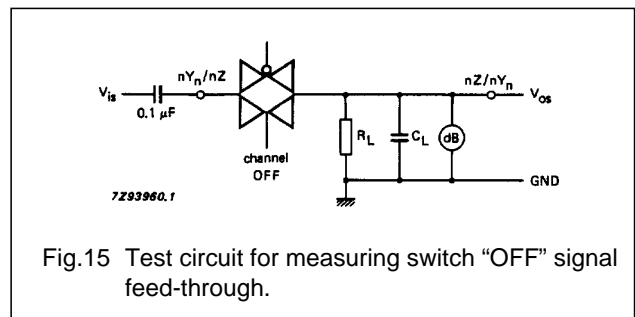
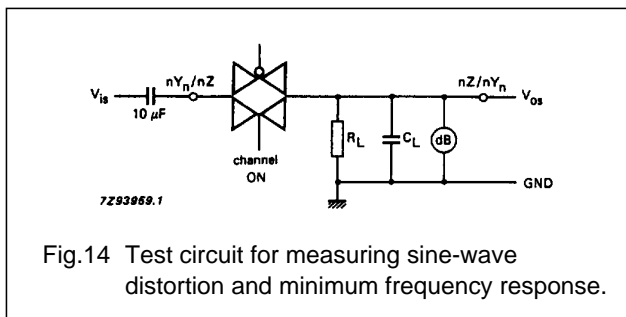
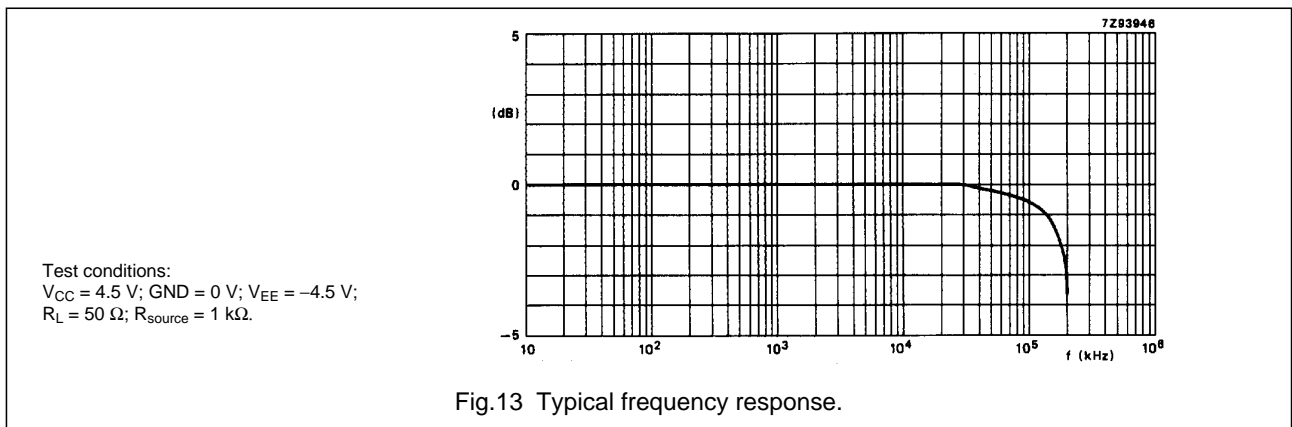
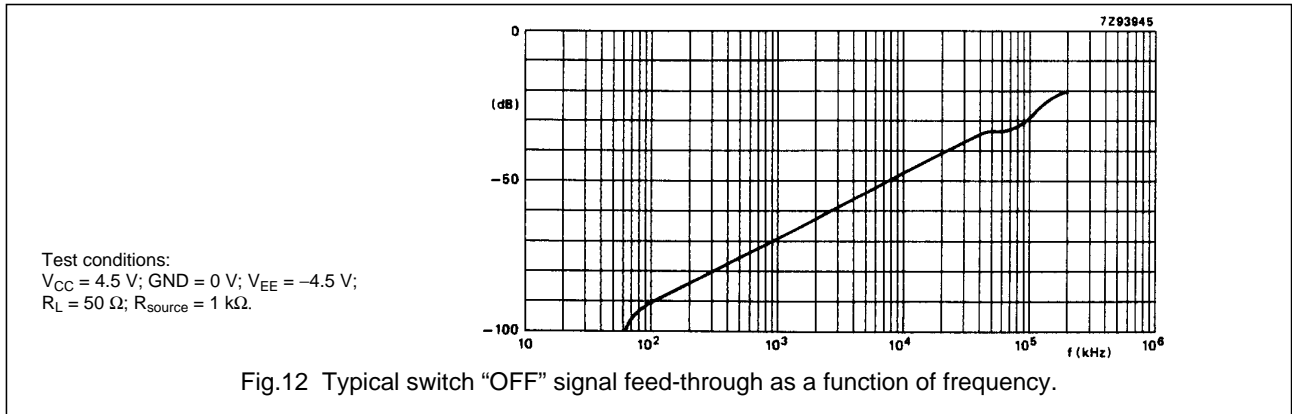

Dual 4-channel analog multiplexer/demultiplexer

74HC/HCT4052

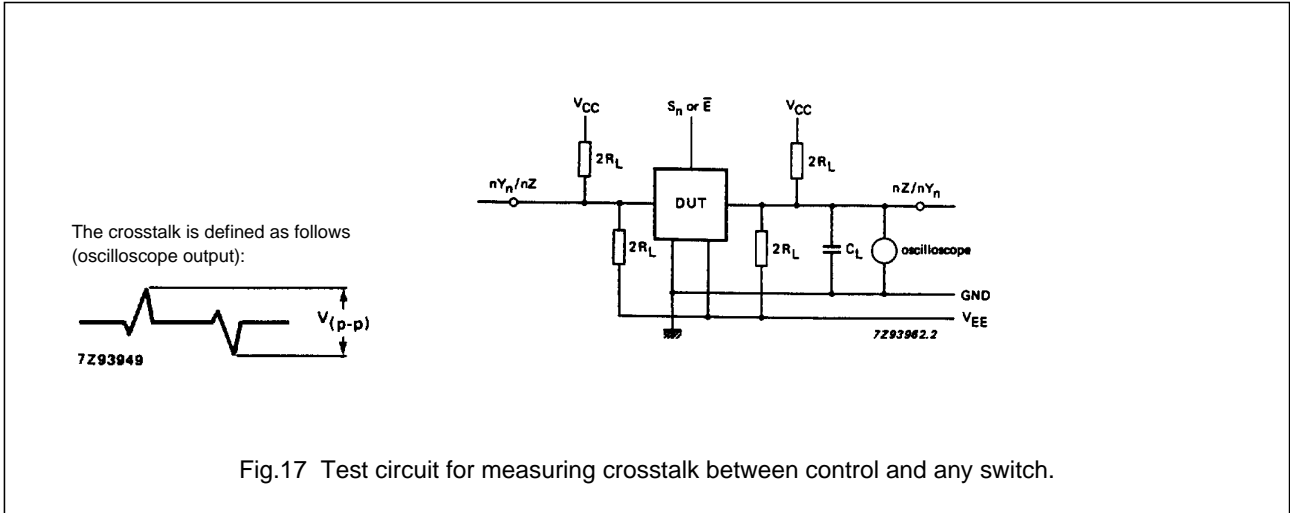

Fig.17 Test circuit for measuring crosstalk between control and any switch.

AC WAVEFORMS

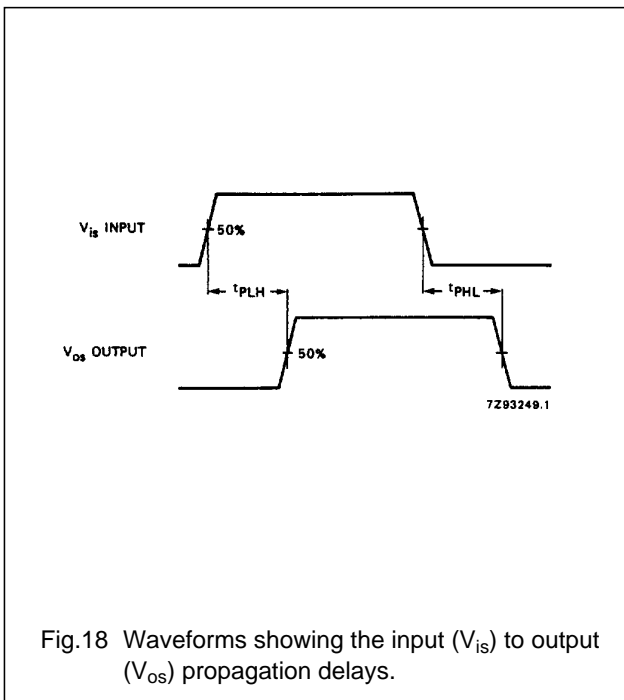

Fig.18 Waveforms showing the input (V_{is}) to output (V_{os}) propagation delays.

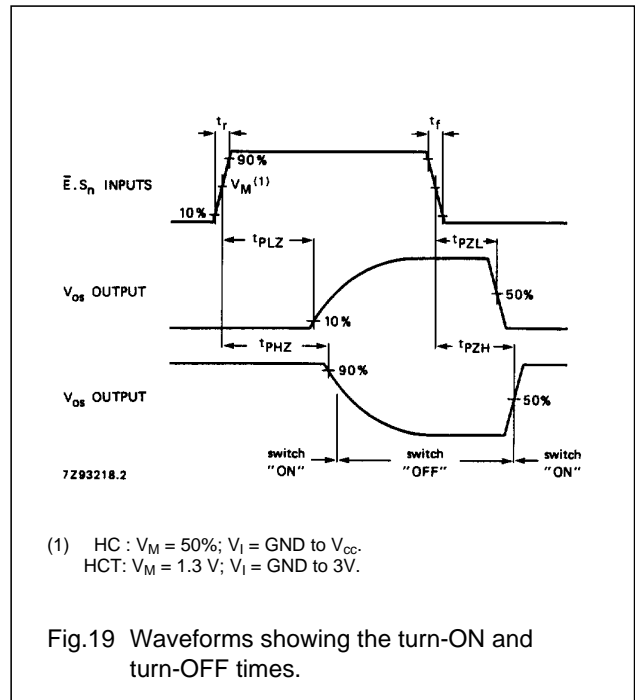
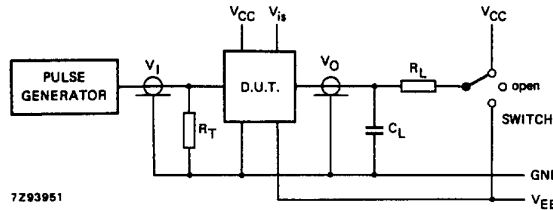

Fig.19 Waveforms showing the turn-ON and turn-OFF times.

Dual 4-channel analog multiplexer/demultiplexer

74HC/HCT4052

TEST CIRCUIT AND WAVEFORMS



Conditions

TEST	SWITCH	V_{is}
t_{PZH}	V_{EE}	V_{CC}
t_{PZL}	V_{CC}	V_{EE}
t_{PHZ}	V_{EE}	V_{CC}
t_{PLZ}	V_{CC}	V_{EE}
others	open	pulse

FAMILY	AMPLITUDE	V_M	$t_r; t_f$	
			$f_{max};$ PULSE WIDTH	OTHER
74HC	V_{CC}	50%	< 2 ns	6 ns
74HCT	3.0 V	1.3 V	< 2 ns	6 ns

C_L = load capacitance including jig and probe capacitance (see AC CHARACTERISTICS for values).
 R_T = termination resistance should be equal to the output impedance Z_O of the pulse generator.
 $t_r = t_f = 6$ ns; when measuring f_{max} , there is no constraint to t_r, t_f with 50% duty factor.

Fig.20 Test circuit for measuring AC performance.

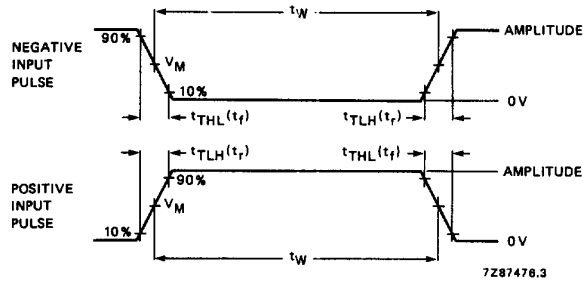

Conditions

TEST	SWITCH	V_{is}
t_{PZH}	V_{EE}	V_{CC}
t_{PZL}	V_{CC}	V_{EE}
t_{PHZ}	V_{EE}	V_{CC}
t_{PLZ}	V_{CC}	V_{EE}
others	open	pulse

FAMILY	AMPLITUDE	V_M	$t_r; t_f$	
			$f_{max};$ PULSE WIDTH	OTHER
74HC	V_{CC}	50%	< 2 ns	6 ns
74HCT	3.0 V	1.3 V	< 2 ns	6 ns

C_L = load capacitance including jig and probe capacitance (see AC CHARACTERISTICS for values).
 R_T = termination resistance should be equal to the output impedance Z_O of the pulse generator.
 $t_r = t_f = 6$ ns; when measuring f_{max} , there is no constraint to t_r, t_f with 50% duty factor.

Fig.21 Input pulse definitions.

Dual 4-channel analog
multiplexer/demultiplexer

74HC/HCT4052

PACKAGE OUTLINES

See *"74HC/HCT/HCU/HCMOS Logic Package Outlines"*.