

# DATA SHEET

For a complete data sheet, please also download:

- The IC06 74HC/HCT/HCU/HCMOS Logic Family Specifications
- The IC06 74HC/HCT/HCU/HCMOS Logic Package Information
- The IC06 74HC/HCT/HCU/HCMOS Logic Package Outlines

## **74HC/HCT4515**

**4-to-16 line decoder/demultiplexer  
with input latches; inverting**

Product specification  
File under Integrated Circuits, IC06

September 1993

## 4-to-16 line decoder/demultiplexer with input latches; inverting

## 74HC/HCT4515

### FEATURES

- Inverting outputs
- Output capability: standard
- $I_{CC}$  category: MSI

### GENERAL DESCRIPTION

The 74HC/HCT4515 are high-speed Si-gate CMOS devices and are pin compatible with "4515" of the "4000B" series. They are specified in compliance with JEDEC standard no. 7A.

The 74HC/HCT4515 are 4-to-16 line decoders/demultiplexers having four binary weighted address inputs ( $A_0$  to  $A_3$ ) with latches, a latch enable input (LE), and an active LOW enable input ( $\bar{E}$ ). The 16 inverting outputs ( $\bar{Q}_0$  to  $\bar{Q}_{15}$ ) are mutually exclusive active LOW. When LE is HIGH, the selected output is determined by the data on  $A_n$ . When LE goes LOW, the last data present at  $A_n$  are stored in the latches and the outputs remain stable. When  $\bar{E}$  is LOW, the selected output, determined by the contents of the latch, is LOW. When  $\bar{E}$  is HIGH, all outputs are HIGH. The enable input ( $\bar{E}$ ) does not affect the state of the latch.

When the "4515" is used as a demultiplexer,  $\bar{E}$  is the data input and  $A_0$  to  $A_3$  are the address inputs.

### QUICK REFERENCE DATA

GND = 0 V;  $T_{amb} = 25\text{ }^\circ\text{C}$ ;  $t_r = t_f = 6\text{ ns}$

SYMBOL	PARAMETER	CONDITIONS	TYPICAL		UNIT
			HC	HCT	
$t_{PHL}/t_{PLH}$	propagation delay $A_n$ to $\bar{Q}_n$	$C_L = 15\text{ pF}$ ; $V_{CC} = 5\text{ V}$	25	26	ns
$C_I$	input capacitance		3.5	3.5	pF
$C_{PD}$	power dissipation capacitance per package	notes 1 and 2	44	46	pF

### Notes

1.  $C_{PD}$  is used to determine the dynamic power dissipation ( $P_D$  in  $\mu\text{W}$ ):

$$P_D = C_{PD} \times V_{CC}^2 \times f_i + \sum (C_L \times V_{CC}^2 \times f_o) \text{ where:}$$

$f_i$  = input frequency in MHz

$f_o$  = output frequency in MHz

$\sum (C_L \times V_{CC}^2 \times f_o)$  = sum of outputs

$C_L$  = output load capacitance in pF

$V_{CC}$  = supply voltage in V

2. For HC the condition is  $V_I = \text{GND to } V_{CC}$   
For HCT the condition is  $V_I = \text{GND to } V_{CC} - 1.5\text{ V}$

### ORDERING INFORMATION

See "74HC/HCT/HCU/HCMOS Logic Package Information".

4-to-16 line decoder/demultiplexer with  
input latches; inverting

74HC/HCT4515

PIN DESCRIPTION

PIN NO.	SYMBOL	NAME AND FUNCTION
1	LE	latch enable input (active HIGH)
2, 3, 21, 22	A <sub>0</sub> to A <sub>3</sub>	address inputs
11, 9, 10, 8, 7, 6, 5, 4, 18, 17, 20, 19, 14, 13, 16, 15	$\bar{Q}_0$ to $\bar{Q}_{15}$	multiplexer outputs (active LOW)
12	GND	ground (0 V)
23	$\bar{E}$	enable input (active LOW)
24	V <sub>CC</sub>	positive supply voltage

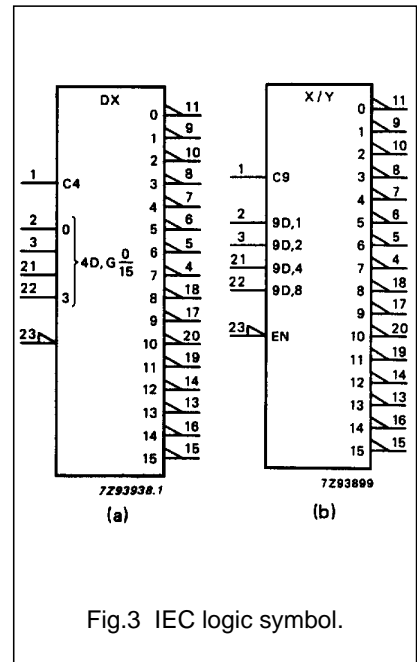
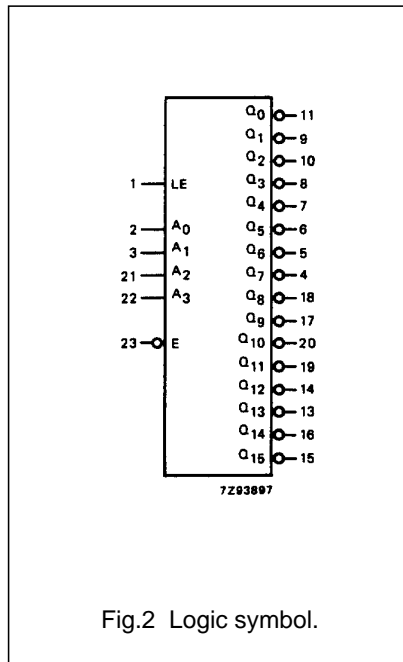
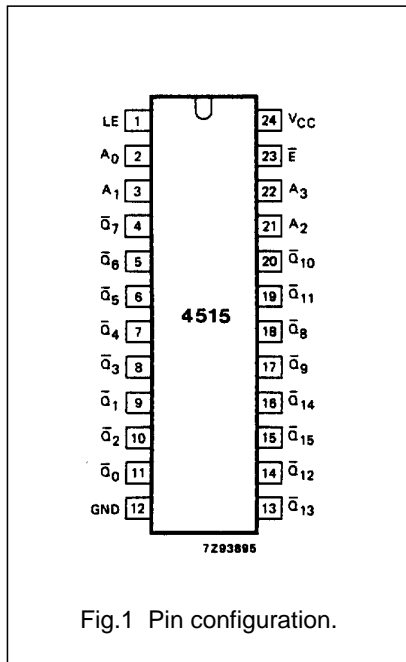

4-to-16 line decoder/demultiplexer with input latches; inverting

74HC/HCT4515

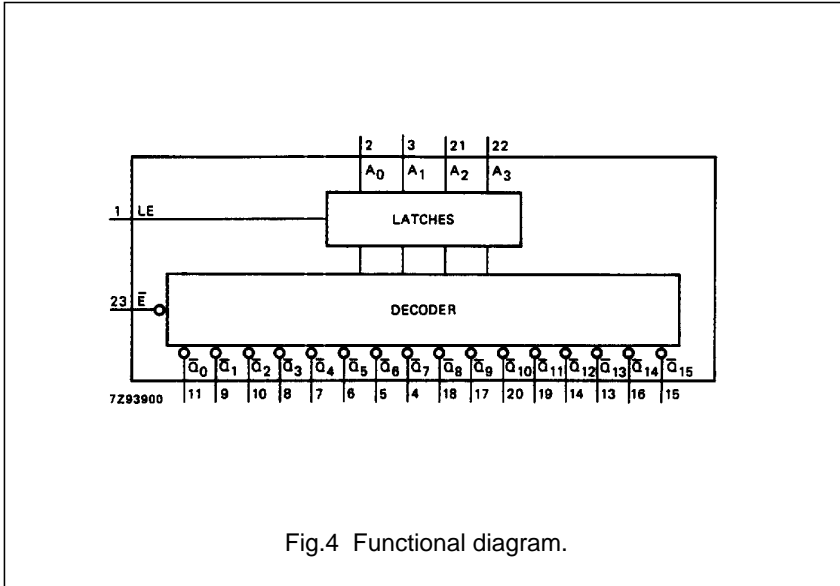

Fig.4 Functional diagram.

APPLICATIONS

- Digital multiplexing
- Address decoding
- Hexadecimal/BCD decoding

FUNCTION TABLE

INPUTS					OUTPUTS																
$\bar{E}$	A <sub>0</sub>	A <sub>1</sub>	A <sub>2</sub>	A <sub>3</sub>	$\bar{Q}_0$	$\bar{Q}_1$	$\bar{Q}_2$	$\bar{Q}_3$	$\bar{Q}_4$	$\bar{Q}_5$	$\bar{Q}_6$	$\bar{Q}_7$	$\bar{Q}_8$	$\bar{Q}_9$	$\bar{Q}_{10}$	$\bar{Q}_{11}$	$\bar{Q}_{12}$	$\bar{Q}_{13}$	$\bar{Q}_{14}$	$\bar{Q}_{15}$	
H	X	X	X	X	H	H	H	H	H	H	H	H	H	H	H	H	H	H	H	H	H
L	L	L	L	L	L	H	H	H	H	H	H	H	H	H	H	H	H	H	H	H	H
L	L	L	L	L	H	L	H	H	H	H	H	H	H	H	H	H	H	H	H	H	H
L	L	L	L	L	H	H	L	H	H	H	H	H	H	H	H	H	H	H	H	H	H
L	L	L	L	L	H	H	H	L	H	H	H	H	H	H	H	H	H	H	H	H	H
L	L	L	L	L	H	H	H	H	L	H	H	H	H	H	H	H	H	H	H	H	H
L	L	L	L	L	H	H	H	H	H	L	H	H	H	H	H	H	H	H	H	H	H
L	L	L	L	L	H	H	H	H	H	H	L	H	H	H	H	H	H	H	H	H	H
L	L	L	L	L	H	H	H	H	H	H	H	L	H	H	H	H	H	H	H	H	H
L	L	L	L	L	H	H	H	H	H	H	H	H	L	H	H	H	H	H	H	H	H
L	L	L	L	L	H	H	H	H	H	H	H	H	H	L	H	H	H	H	H	H	H
L	L	L	L	L	H	H	H	H	H	H	H	H	H	H	L	H	H	H	H	H	H
L	L	L	L	L	H	H	H	H	H	H	H	H	H	H	H	L	H	H	H	H	H
L	L	L	L	L	H	H	H	H	H	H	H	H	H	H	H	H	L	H	H	H	H
L	L	L	L	L	H	H	H	H	H	H	H	H	H	H	H	H	H	L	H	H	H
L	L	L	L	L	H	H	H	H	H	H	H	H	H	H	H	H	H	H	L	H	H
L	L	L	L	L	H	H	H	H	H	H	H	H	H	H	H	H	H	H	H	L	H
L	L	L	L	L	H	H	H	H	H	H	H	H	H	H	H	H	H	H	H	H	L

Notes

- LE = HIGH  
 H = HIGH voltage level  
 L = LOW voltage level  
 X = don't care

4-to-16 line decoder/demultiplexer with  
input latches; inverting

74HC/HCT4515

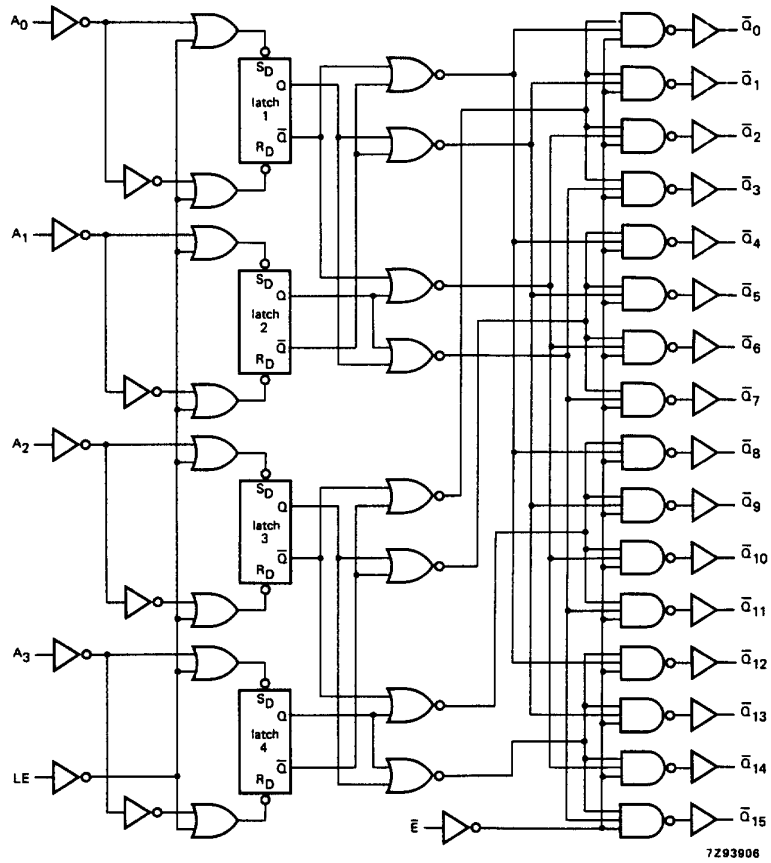

Fig.5 Logic diagram.

## 4-to-16 line decoder/demultiplexer with input latches; inverting

74HC/HCT4515

### DC CHARACTERISTICS FOR 74HC

For the DC characteristics see *"74HC/HCT/HCU/HCMOS Logic Family Specifications"*.

Output capability: standard

I<sub>CC</sub> category: MSI

### AC CHARACTERISTICS FOR 74HC

GND = 0 V; t<sub>r</sub> = t<sub>f</sub> = 6 ns; C<sub>L</sub> = 50 pF

SYMBOL	PARAMETER	T <sub>amb</sub> (°C)							UNIT	TEST CONDITIONS	
		74HC								V <sub>CC</sub> (V)	WAVEFORMS
		+25			-40 to +85		-40 to +125				
		min.	typ.	max.	min.	max.	min.	max.			
t <sub>PHL</sub> / t <sub>PLH</sub>	propagation delay A <sub>n</sub> to Q <sub>n</sub>		80 29 23	250 50 43		315 63 54		375 75 64	ns	2.0 4.5 6.0	Fig.6
t <sub>PHL</sub> / t <sub>PLH</sub>	propagation delay LE to Q <sub>n</sub>		66 24 19	225 45 38		280 56 48		340 68 58	ns	2.0 4.5 6.0	Fig.6
t <sub>PHL</sub> / t <sub>PLH</sub>	propagation delay Ē to Q <sub>n</sub>		50 18 14	175 35 30		220 44 37		265 53 45	ns	2.0 4.5 6.0	Fig.6
t <sub>THL</sub> / t <sub>TLH</sub>	output transition time		19 7 6	75 15 13		95 19 16		110 22 19	ns	2.0 4.5 6.0	Fig.6
t <sub>W</sub>	latch enable pulse width HIGH	75 15 13	14 5 4		95 19 16		110 22 19		ns	2.0 4.5 6.0	Fig.7
t <sub>su</sub>	set-up time A <sub>n</sub> to LE	90 18 15	28 10 8		115 23 20		135 27 23		ns	2.0 4.5 6.0	Fig.7
t <sub>h</sub>	hold time A <sub>n</sub> to LE	0 0 0	-11 -4 -3		0 0 0		0 0 0		ns	2.0 4.5 6.0	Fig.7

## 4-to-16 line decoder/demultiplexer with input latches; inverting

74HC/HCT4515

### DC CHARACTERISTICS FOR 74HCT

For the DC characteristics see *"74HC/HCT/HCU/HCMOS Logic Family Specifications"*.

Output capability: standard

I<sub>CC</sub> category: MSI

#### Note to HCT types

The value of additional quiescent supply current ( $\Delta I_{CC}$ ) for a unit load of 1 is given in the family specifications.

To determine  $\Delta I_{CC}$  per input, multiply this value by the unit load coefficient shown in the table below.

INPUT	UNIT LOAD COEFFICIENT
A <sub>n</sub>	0.65
LE	1.40
$\bar{E}$	1.00

### AC CHARACTERISTICS FOR 74HCT

GND = 0 V; t<sub>r</sub> = t<sub>f</sub> = 6 ns; C<sub>L</sub> = 50 pF

SYMBOL	PARAMETER	T <sub>amb</sub> (°C)						UNIT	TEST CONDITIONS		
		74HCT							V <sub>CC</sub> (V)	WAVEFORMS	
		+25			-40 to +85		-40 to +125				
		min.	typ.	max.	min.	max.	min.				max.
t <sub>PHL</sub> / t <sub>PLH</sub>	propagation delay A <sub>n</sub> to $\bar{Q}_n$		30	55		69		83	ns	4.5	Fig.6
t <sub>PHL</sub> / t <sub>PLH</sub>	propagation delay LE to $\bar{Q}_n$		29	50		63		75	ns	4.5	Fig.6
t <sub>PHL</sub> / t <sub>PLH</sub>	propagation delay $\bar{E}$ to $\bar{Q}_n$		18	40		50		60	ns	4.5	Fig.6
t <sub>THL</sub> / t <sub>TLH</sub>	output transition time		7	15		19		22	ns	4.5	Fig.6
t <sub>W</sub>	latch enable pulse width HIGH	16	3		20		24		ns	4.5	Fig.7
t <sub>SU</sub>	set-up time A <sub>n</sub> to LE	18	9		23		27		ns	4.5	Fig.7
t <sub>H</sub>	hold time A <sub>n</sub> to LE	3	-2		3		3		ns	4.5	Fig.7

4-to-16 line decoder/demultiplexer with  
input latches; inverting

74HC/HCT4515

AC WAVEFORMS

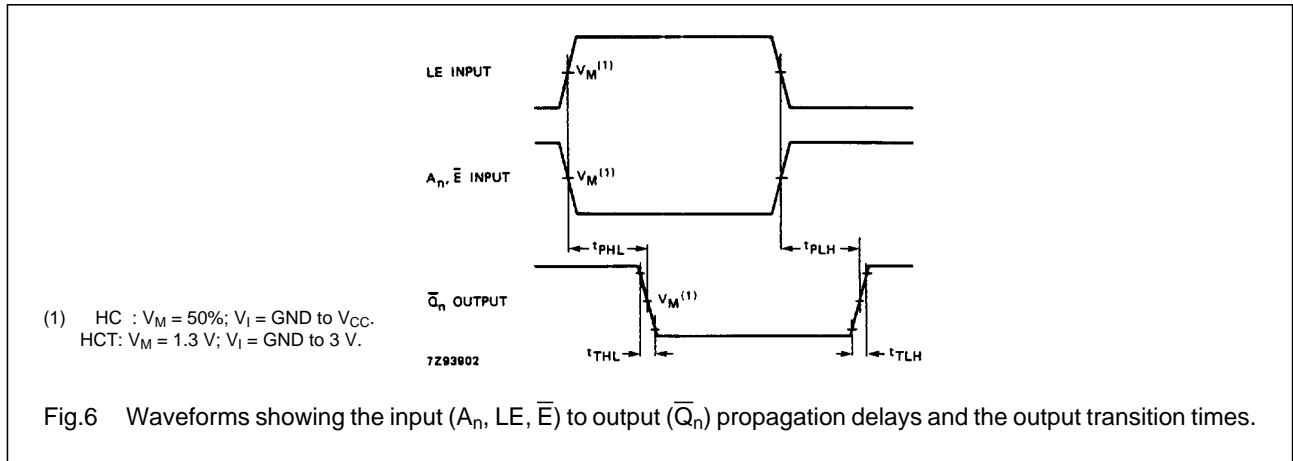

Fig.6 Waveforms showing the input ( $A_n$ , LE,  $\bar{E}$ ) to output ( $\bar{Q}_n$ ) propagation delays and the output transition times.

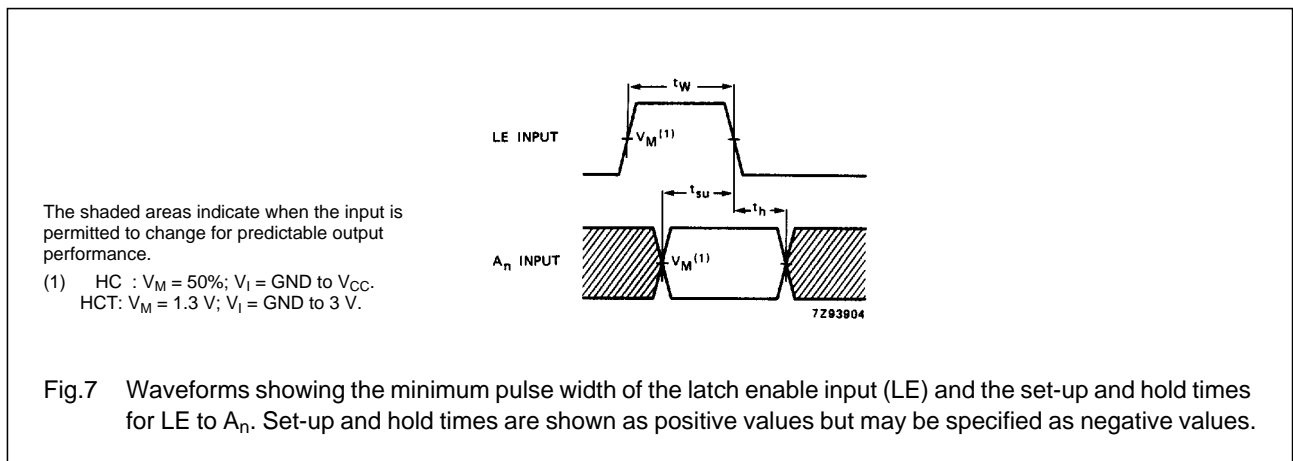

Fig.7 Waveforms showing the minimum pulse width of the latch enable input (LE) and the set-up and hold times for LE to  $A_n$ . Set-up and hold times are shown as positive values but may be specified as negative values.

PACKAGE OUTLINES

See "74HC/HCT/HCU/HCMOS Logic Package Outlines".