

DATA SHEET

For a complete data sheet, please also download:

- The IC06 74HC/HCT/HCU/HCMOS Logic Family Specifications
- The IC06 74HC/HCT/HCU/HCMOS Logic Package Information
- The IC06 74HC/HCT/HCU/HCMOS Logic Package Outlines

74HC/HCT93 4-bit binary ripple counter

Product specification
File under Integrated Circuits, IC06

December 1990

4-bit binary ripple counter

74HC/HCT93

FEATURES

- Various counting modes
- Asynchronous master reset
- Output capability: standard
- I_{CC} category: MSI

GENERAL DESCRIPTION

The 74HC/HCT93 are high-speed Si-gate CMOS devices and are pin compatible with low power Schottky TTL (LSTTL). They are specified in compliance with JEDEC standard no. 7A.

The 74HC/HCT93 are 4-bit binary ripple counters. The devices consist of four master-slave flip-flops internally connected to provide a

divide-by-two section and a divide-by-eight section. Each section has a separate clock input (\overline{CP}_0 and \overline{CP}_1) to initiate state changes of the counter on the HIGH-to-LOW clock transition. State changes of the Q_n outputs do not occur simultaneously because of internal ripple delays. Therefore, decoded output signals are subject to decoding spikes and should not be used for clocks or strobes.

A gated AND asynchronous master reset (MR₁ and MR₂) is provided which overrides both clocks and resets (clears) all flip-flops.

Since the output from the divide-by-two section is not internally connected to the succeeding stages,

the device may be operated in various counting modes. In a 4-bit ripple counter the output Q₀ must be connected externally to input \overline{CP}_1 . The input count pulses are applied to clock input \overline{CP}_0 . Simultaneous frequency divisions of 2, 4, 8 and 16 are performed at the Q₀, Q₁, Q₂ and Q₃ outputs as shown in the function table. As a 3-bit ripple counter the input count pulses are applied to input \overline{CP}_1 .

Simultaneous frequency divisions of 2, 4 and 8 are available at the Q₁, Q₂ and Q₃ outputs. Independent use of the first flip-flop is available if the reset function coincides with reset of the 3-bit ripple-through counter.

QUICK REFERENCE DATA

GND = 0 V; T_{amb} = 25 °C; t_r = t_f = 6 ns

SYMBOL	PARAMETER	CONDITIONS	TYPICAL		UNIT
			HC	HCT	
t _{PHL} / t _{PLH}	propagation delay \overline{CP}_0 to Q ₀	C _L = 15 pF; V _{CC} = 5 V	12	15	ns
f _{max}	maximum clock frequency		100	77	MHz
C _I	input capacitance		3.5	3.5	pF
C _{PD}	power dissipation capacitance per package	notes 1 and 2	22	22	pF

Notes

1. C_{PD} is used to determine the dynamic power dissipation (P_D in μW):

$$P_D = C_{PD} \times V_{CC}^2 \times f_i + \sum (C_L \times V_{CC}^2 \times f_o) \text{ where:}$$

f_i = input frequency in MHz; f_o = output frequency in MHz

∑ (C_L × V_{CC}² × f_o) = sum of outputs

C_L = output load capacitance in pF; V_{CC} = supply voltage in V

2. For HC the condition is V_I = GND to V_{CC}; for HCT the condition is V_I = GND to V_{CC} – 1.5 V

ORDERING INFORMATION

See "74HC/HCT/HCU/HCMOS Logic Package Information".

4-bit binary ripple counter

74HC/HCT93

PIN DESCRIPTION

PIN NO.	SYMBOL	NAME AND FUNCTION
1	\overline{CP}_1	clock input 2 nd , 3 rd and 4 th section (HIGH-to-LOW, edge-triggered)
2, 3	MR_1, MR_2	asynchronous master reset (active HIGH)
4, 6, 7, 13	n.c.	not connected
5	V_{CC}	positive supply voltage
10	GND	ground (0 V)
12, 9, 8, 11	Q_0 to Q_3	flip-flop outputs
14	\overline{CP}_0	clock input 1 st section (HIGH-to-LOW, edge-triggered)

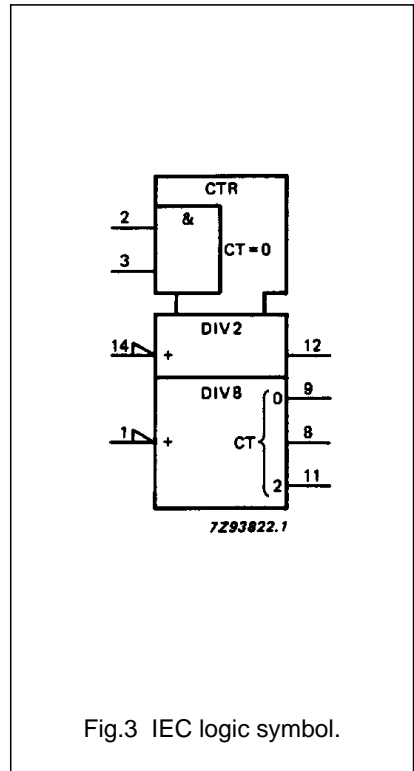
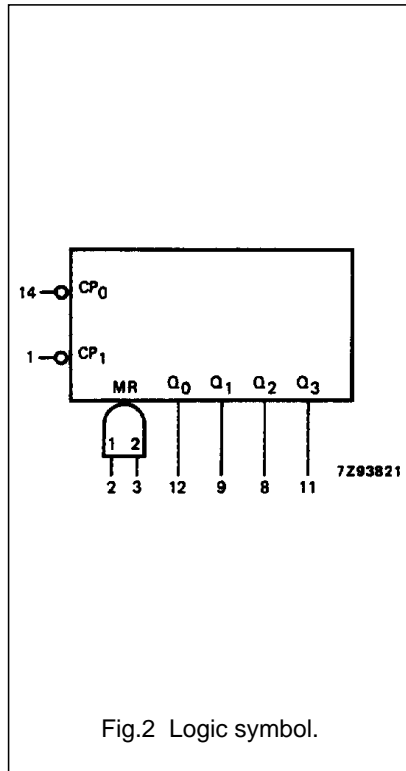
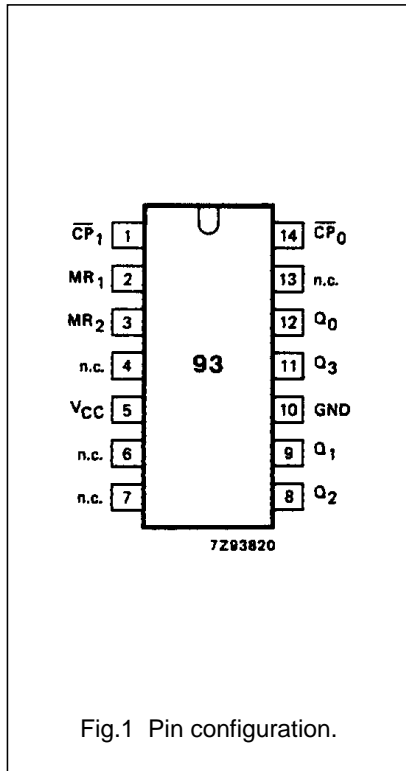

4-bit binary ripple counter

74HC/HCT93

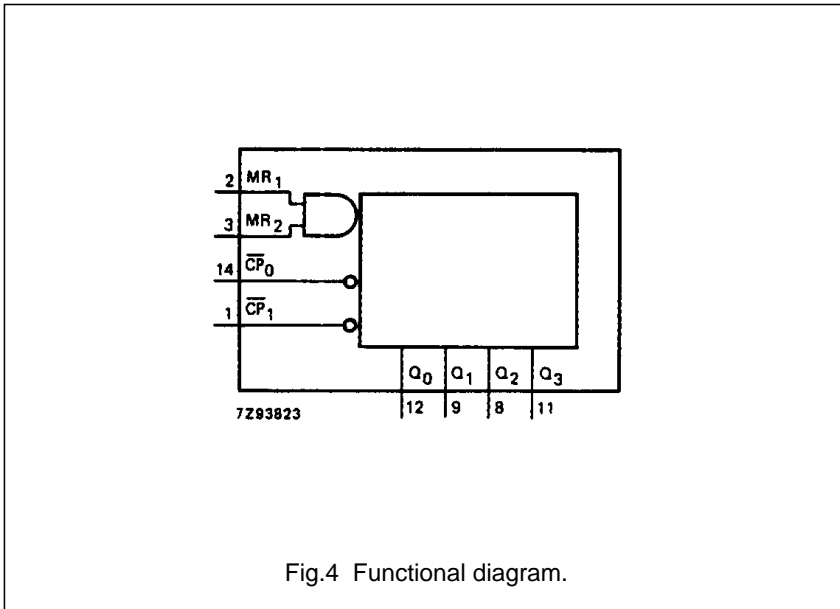

Fig.4 Functional diagram.

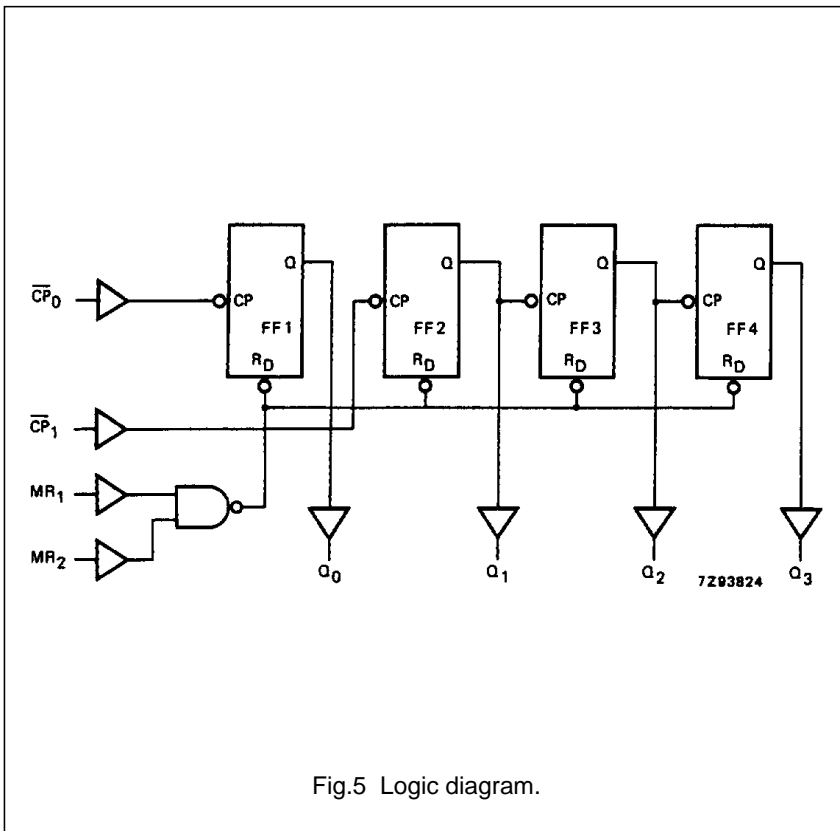

Fig.5 Logic diagram.

FUNCTION TABLE

COUNT	OUTPUTS			
	Q ₀	Q ₁	Q ₂	Q ₃
0	L	L	L	L
1	H	L	L	L
2	L	H	L	L
3	H	H	L	L
4	L	L	H	L
5	H	L	H	L
6	L	H	H	L
7	H	H	H	L
8	L	L	L	H
9	H	L	L	H
10	L	H	L	H
11	H	H	L	H
12	L	L	H	H
13	H	L	H	H
14	L	H	H	H
15	H	H	H	H

Notes

- Output Q₀ connected to \overline{CP}_1 .
H = HIGH voltage level
L = LOW voltage level

MODE SELECTION

RESET INPUTS		OUTPUTS			
MR ₁	MR ₂	Q ₀	Q ₁	Q ₂	Q ₃
H	H	L	L	L	L
L	H	count			
H	L	count			
L	L	count			

4-bit binary ripple counter

74HC/HCT93

DC CHARACTERISTICS FOR 74HC

For the DC characteristics see *"74HC/HCT/HCU/HCMOS Logic Family Specifications"*.

Output capability: standard

I_{CC} category: MSI

AC CHARACTERISTICS FOR 74HC

GND = 0 V; t_r = t_f = 6 ns; C_L = 50 pF

SYMBOL	PARAMETER	T _{amb} (°C)							UNIT	TEST CONDITIONS	
		74HC								V _{CC} (V)	WAVEFORMS
		+25			-40 to +85		-40 to +125				
		min.	typ.	max.	min.	max.	min.	max.			
t _{PHL} / t _{PLH}	propagation delay CP ₀ to Q ₀		41 15 12	125 25 21		155 31 26		190 38 32	ns	2.0 4.5 6.0	Fig.6
t _{PHL} / t _{PLH}	propagation delay CP ₁ to Q ₁		49 16 13	135 27 23		170 34 29		205 41 35	ns	2.0 4.5 6.0	Fig.6
t _{PHL} / t _{PLH}	propagation delay CP ₁ to Q ₂		61 22 18	185 37 31		230 46 39		280 56 48	ns	2.0 4.5 6.0	Fig.6
t _{PHL} / t _{PLH}	propagation delay CP ₁ to Q ₃		80 29 23	245 49 42		305 61 52		370 71 63	ns	2.0 4.5 6.0	Fig.6
t _{PHL}	propagation delay MR _n to Q _n		50 18 14	155 31 26		195 39 33		235 47 40	ns	2.0 4.5 6.0	Fig.7
t _{THL} / t _{TLH}	output transition time		19 7 6	75 15 13		95 19 16		110 22 19	ns	2.0 4.5 6.0	Fig.6
t _{rem}	removal time MR _n to CP ₀ , CP ₁	50 10 9	8 3 2		65 13 11		75 15 13		ns	2.0 4.5 6.0	Fig.7
t _w	pulse width CP ₀ , CP ₁	80 16 14	14 5 4		100 20 17		120 24 20		ns	2.0 4.5 6.0	Fig.6
t _w	master reset pulse width MR _n	80 16 14	14 5 4		100 20 17		120 24 20		ns	2.0 4.5 6.0	Fig.7
f _{max}	maximum clock pulse frequency CP ₀ , CP ₁	6.0 30 35	30 91 108		4.8 24 28		4.0 20 24		MHz	2.0 4.5 6.0	Fig.6

4-bit binary ripple counter

74HC/HCT93

DC CHARACTERISTICS FOR 74HCT

For the DC characteristics see *"74HC/HCT/HCU/HCMOS Logic Family Specifications"*.

Output capability: standard

I_{CC} category: MSI

Note to HCT types

The value of additional quiescent supply current (ΔI_{CC}) for a unit load of 1 is given in the family specifications. To determine ΔI_{CC} per input, multiply this value by the unit load coefficient shown in the table below.

INPUT	UNIT LOAD COEFFICIENT
$\overline{CP}_0, \overline{CP}_1$	0.60
MR _n	0.40

AC CHARACTERISTICS FOR 74HCT

GND = 0 V; t_r = t_f = 6 ns; C_L = 50 pF

SYMBOL	PARAMETER	T _{amb} (°C)								UNIT	TEST CONDITIONS	
		74HCT									V _{CC} (V)	WAVEFORMS
		+25			-40 to +85		-40 to +125					
		min.	typ.	max.	min.	max.	min.	max.				
t _{PHL} / t _{PLH}	propagation delay \overline{CP}_0 to Q ₀		18	34		43		51	ns	4.5	Fig.6	
t _{PHL} / t _{PLH}	propagation delay \overline{CP}_1 to Q ₁		18	34		43		51	ns	4.5	Fig.6	
t _{PHL} / t _{PLH}	propagation delay CP ₁ to Q ₂		24	46		58		69	ns	4.5	Fig.6	
t _{PHL} / t _{PLH}	propagation delay CP ₁ to Q ₃		30	58		73		87	ns	4.5	Fig.6	
t _{PHL}	propagation delay MR _n to Q _n		17	33		41		50	ns	4.5	Fig.7	
t _{THL} / t _{TLH}	output transition time		7	15		19		22	ns	4.5	Fig.6	
t _{rem}	removal time MR _n to $\overline{CP}_0, \overline{CP}_1$	10	3		13		15		ns	4.5	Fig.7	
t _W	pulse width $\overline{CP}_0, \overline{CP}_1$	16	7		20		24		ns	4.5	Fig.6	
t _W	master reset pulse width MR _n	16	5		20		24		ns	4.5	Fig.7	
f _{max}	maximum clock pulse frequency CP ₀ , CP ₁	30	70		24		20		MHz	4.5	Fig.6	

4-bit binary ripple counter

74HC/HCT93

AC WAVEFORMS

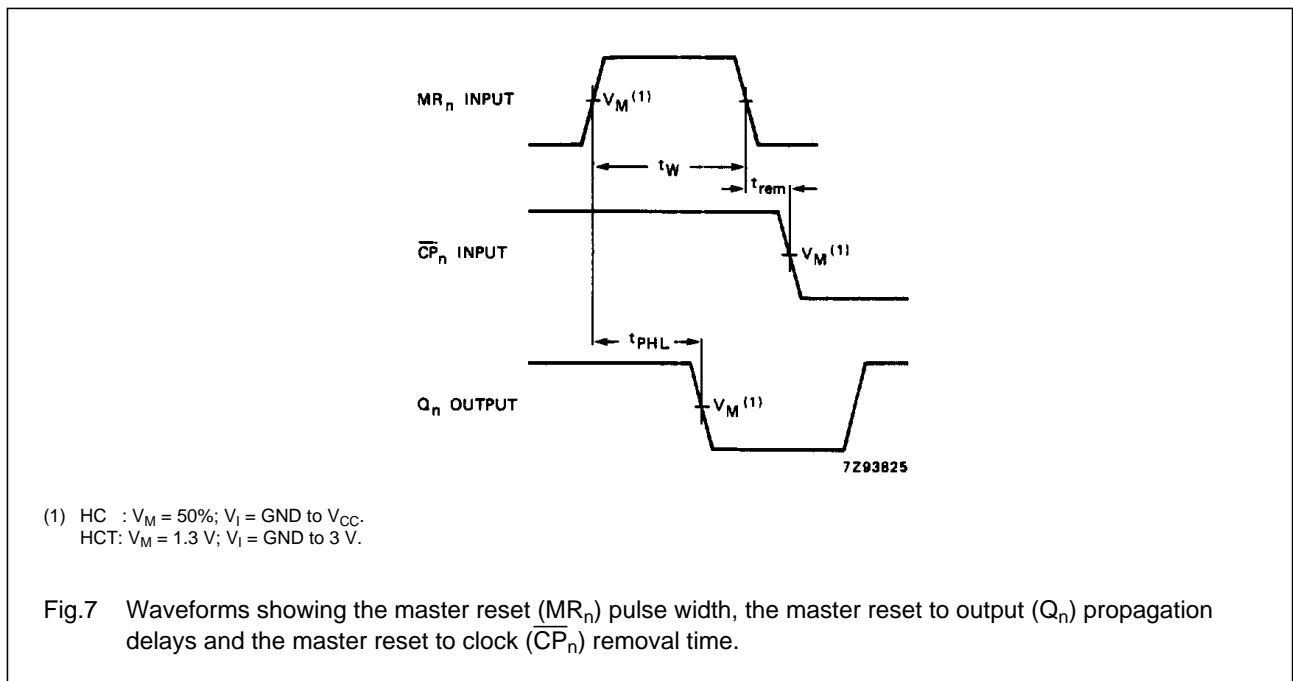
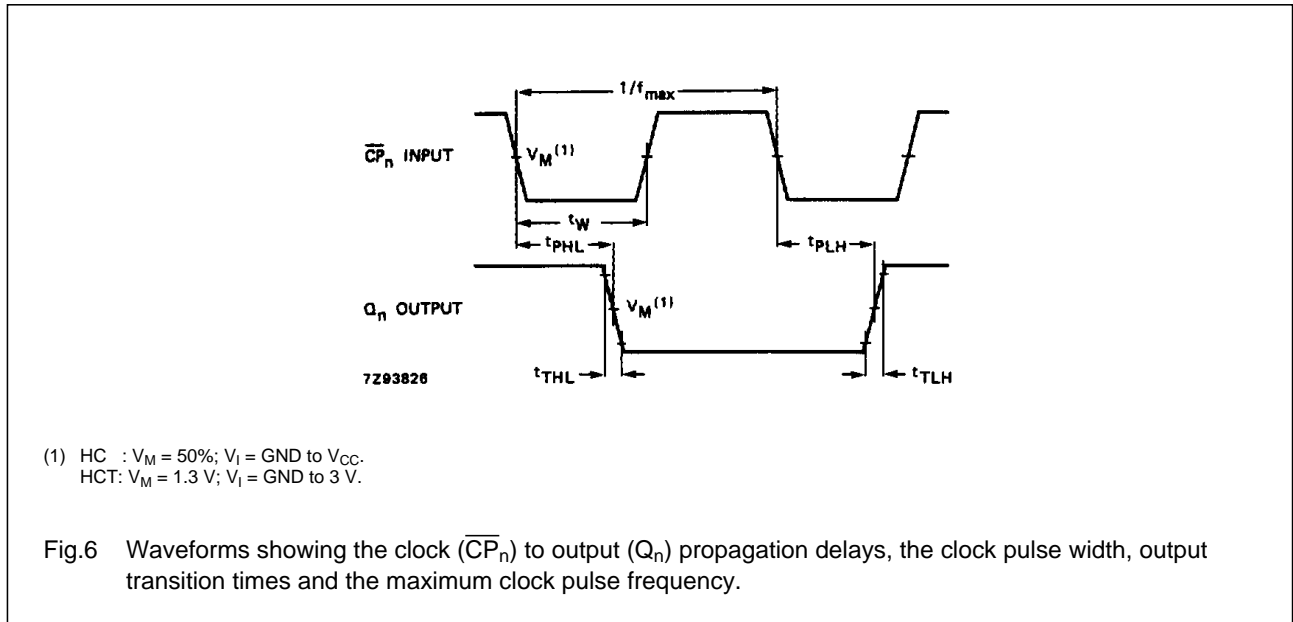

PACKAGE OUTLINES

See "74HC/HCT/HCU/HCMOS Logic Package Outlines".