

DATA SHEET

For a complete data sheet, please also download:

- The IC04 LOCMOS HE4000B Logic Family Specifications HEF, HEC
- The IC04 LOCMOS HE4000B Logic Package Outlines/Information HEF, HEC

HEF4001UB **gates** Quadruple 2-input NOR gate

Product specification
File under Integrated Circuits, IC04

January 1995

Quadruple 2-input NOR gate

HEF4001UB gates

DESCRIPTION

The HEF4001UB is a quadruple 2-input NOR gate. This unbuffered single stage version provides a direct implementation of the NOR function. The output impedance and output transition time depends on the input voltage and input rise and fall times applied.

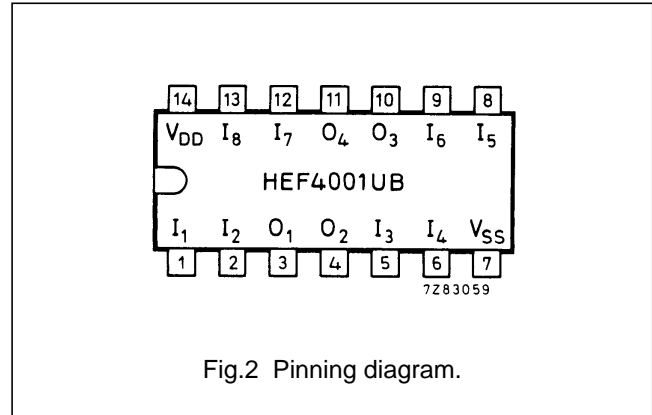
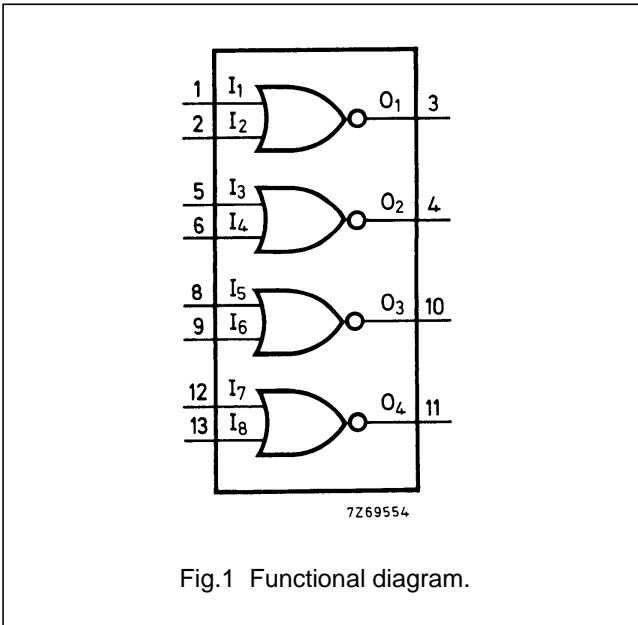

- HEF4001UBP(N): 14-lead DIL; plastic (SOT27-1)
- HEF4001UBD(F): 14-lead DIL; ceramic (cerdip) (SOT73)
- HEF4001UBT(D): 14-lead SO; plastic (SOT108-1)
- (): Package Designator North America

FAMILY DATA, I_{DD} LIMITS category GATES

See Family Specifications for V_{IH}/V_{IL} unbuffered stages

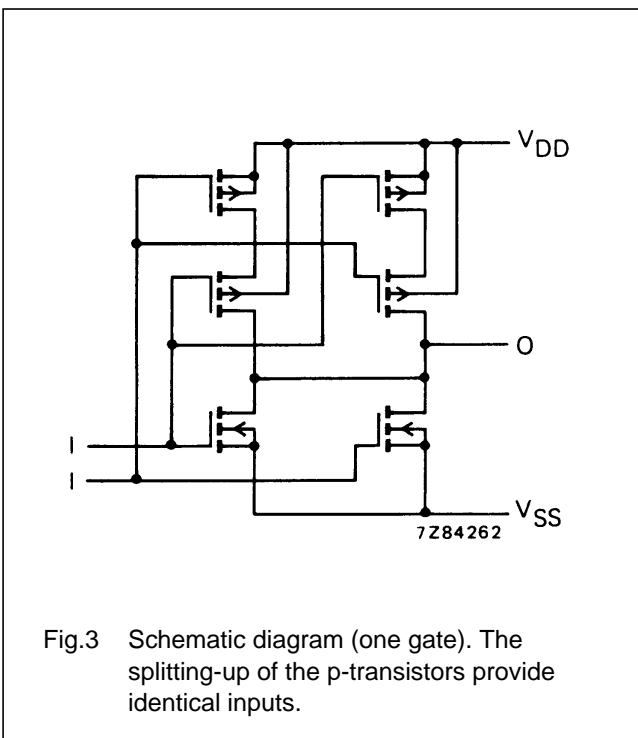

Quadruple 2-input NOR gate

HEF4001UB
gates

AC CHARACTERISTICS

$V_{SS} = 0\text{ V}$; $T_{amb} = 25\text{ }^\circ\text{C}$; $C_L = 50\text{ pF}$; input transition times $\leq 20\text{ ns}$

	V_{DD} V	SYMBOL	TYP.	MAX.		TYPICAL EXTRAPOLATION FORMULA
Propagation delays $I_n \rightarrow O_n$ HIGH to LOW	5	t_{PHL}	65	130	ns	$30\text{ ns} + (0,70\text{ ns/pF}) C_L$
	10		30	60	ns	$17\text{ ns} + (0,27\text{ ns/pF}) C_L$
	15		25	50	ns	$15\text{ ns} + (0,20\text{ ns/pF}) C_L$
LOW to HIGH	5	t_{PLH}	40	80	ns	$13\text{ ns} + (0,55\text{ ns/pF}) C_L$
	10		20	40	ns	$9\text{ ns} + (0,23\text{ ns/pF}) C_L$
	15		15	30	ns	$7\text{ ns} + (0,16\text{ ns/pF}) C_L$
Output transition times HIGH to LOW	5	t_{THL}	75	150	ns	$15\text{ ns} + (1,20\text{ ns/pF}) C_L$
	10		30	60	ns	$6\text{ ns} + (0,48\text{ ns/pF}) C_L$
	15		20	40	ns	$4\text{ ns} + (0,32\text{ ns/pF}) C_L$
LOW to HIGH	5	t_{TLH}	60	110	ns	$10\text{ ns} + (1,00\text{ ns/pF}) C_L$
	10		30	60	ns	$9\text{ ns} + (0,42\text{ ns/pF}) C_L$
	15		20	40	ns	$6\text{ ns} + (0,28\text{ ns/pF}) C_L$
Input capacitance		C_{IN}	–	10	pF	

	V_{DD} V	TYPICAL FORMULA FOR P (μW)	
Dynamic power dissipation per package (P)	5	$500 f_i + \sum (f_o C_L) \times V_{DD}^2$	where f_i = input freq. (MHz) f_o = output freq. (MHz) C_L = load capacitance (pF) $\sum(f_o C_L)$ = sum of outputs V_{DD} = supply voltage (V)
	10	$5000 f_i + \sum (f_o C_L) \times V_{DD}^2$	
	15	$30\ 000 f_i + \sum (f_o C_L) \times V_{DD}^2$	

Quadruple 2-input NOR gate

HEF4001UB
gates

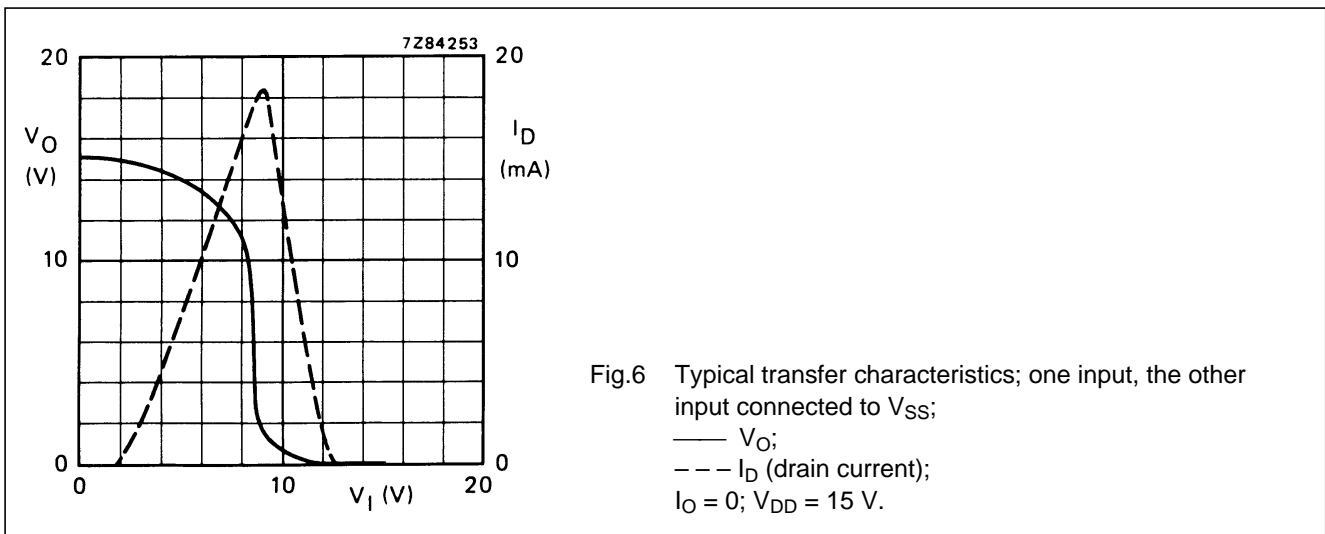
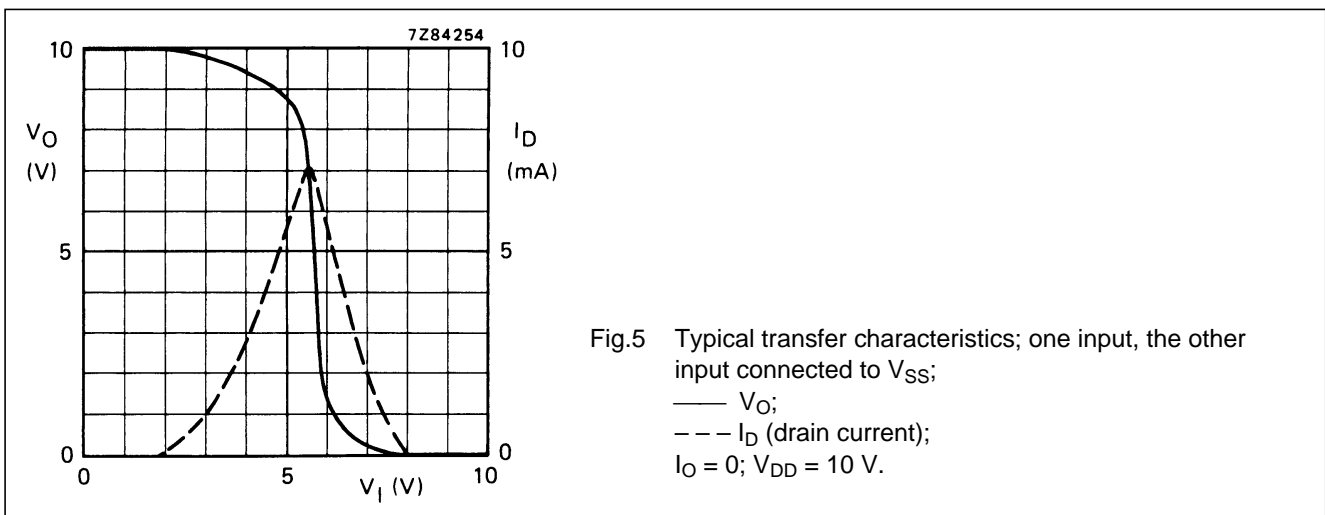
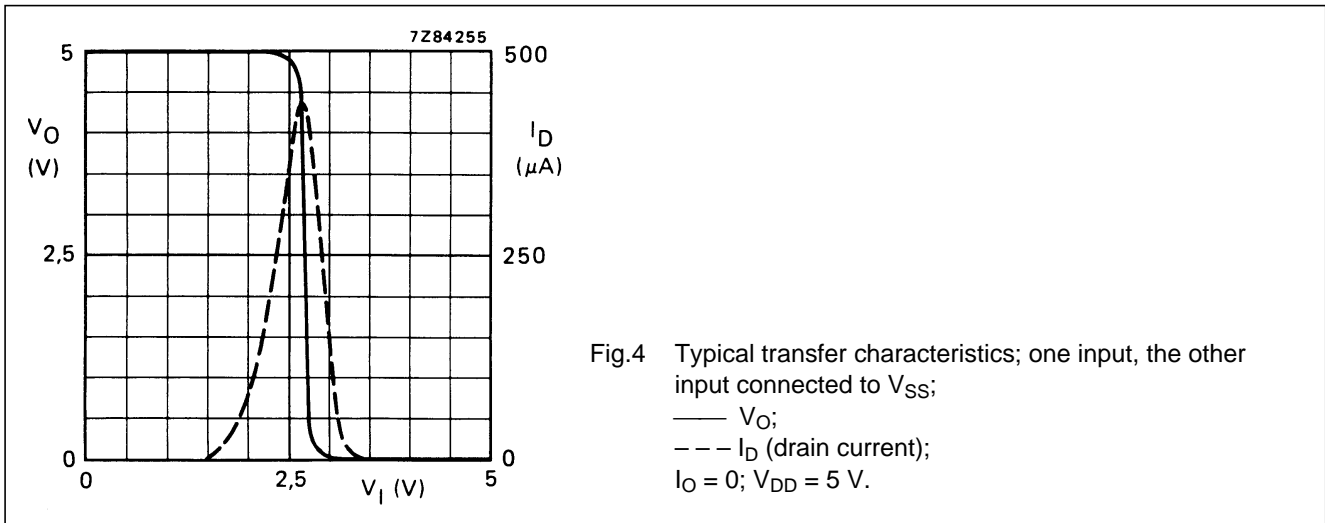

Quadruple 2-input NOR gate

HEF4001UB
gates

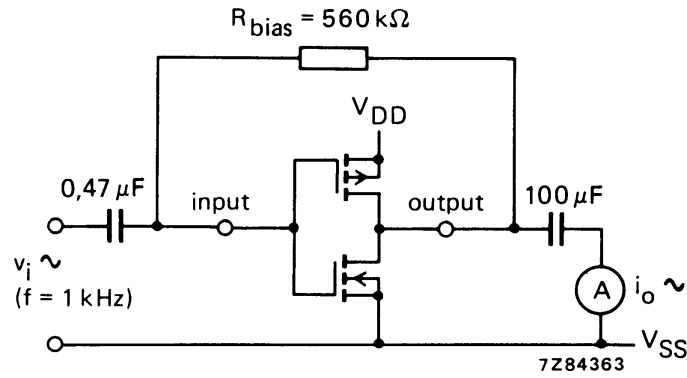
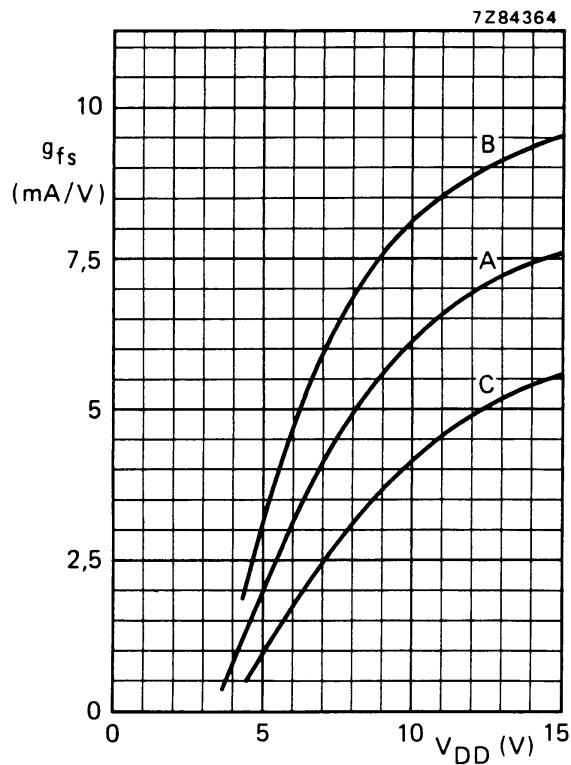

Fig.7 Test set-up for measuring forward transconductance $g_{fs} = di_o/dv_i$ at v_o is constant (see also graph Fig.8).



- A : average,
- B : average + 2 s,
- C : average - 2 s, in where 's' is the observed standard deviation.

Fig.8 Typical forward transconductance g_{fs} as a function of the supply voltage at $T_{amb} = 25\text{ }^\circ\text{C}$.

Quadruple 2-input NOR gate

HEF4001UB gates

APPLICATION INFORMATION

Some examples of applications for the HEF4001UB are shown below. Because of the fact that this circuit is unbuffered, it is suitable for use in (partly) analogue circuits.

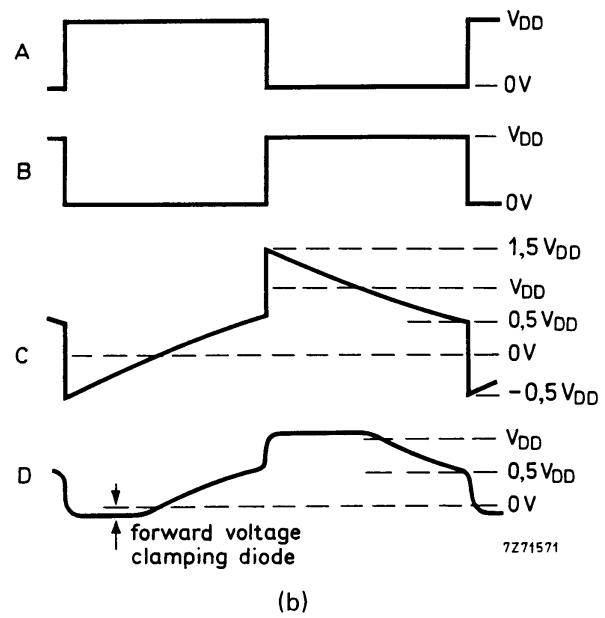
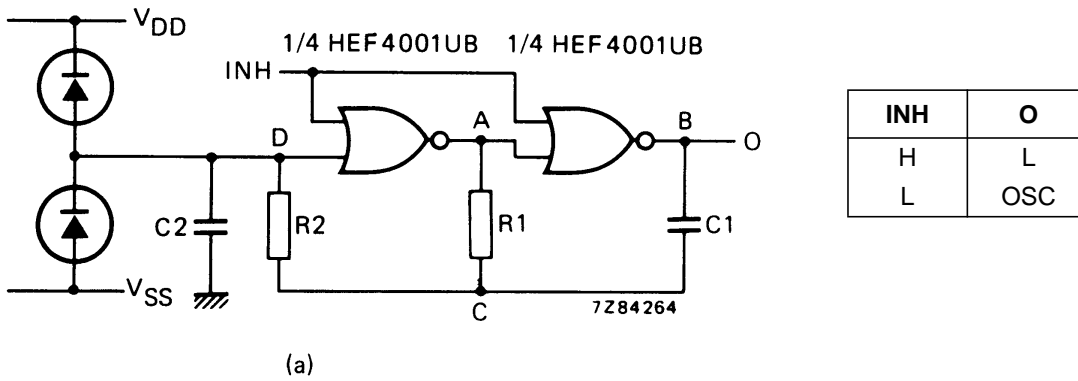

In Fig.9 the oscillation frequency is mainly determined by R1C1, provided $R1 \ll R2$ and $R2C2 \ll R1C1$.

The function of R2 is to minimize the influence of the forward voltage across the protection diodes on the frequency; C2 is a stray (parasitic) capacitance. The period T_p is given by $T_p = T_1 + T_2$, in which

$$T_1 = R1C1 \ln \frac{V_{DD} + V_{ST}}{V_{ST}} \text{ and } T_2 = R1C1 \ln \frac{2V_{DD} - V_{ST}}{V_{DD} - V_{ST}} \text{ where}$$

V_{ST} is the signal threshold level of the gate. The period is fairly independent of V_{DD} , V_{ST} and temperature. The duty factor, however, is influenced by V_{ST} .

Fig.9 (a) Astable relaxation oscillator using two HEF4001UB gates; the diodes may be BAW62; C2 is a parasitic capacitance.
 (b) Waveforms at the points marked A, B, C and D in the circuit diagram.

Quadruple 2-input NOR gate

HEF4001UB
gates

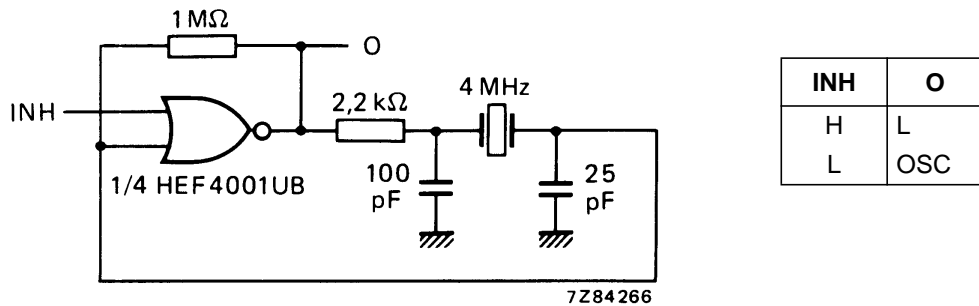

Fig.10 Example of a crystal oscillator using one HEF4001UB gate.

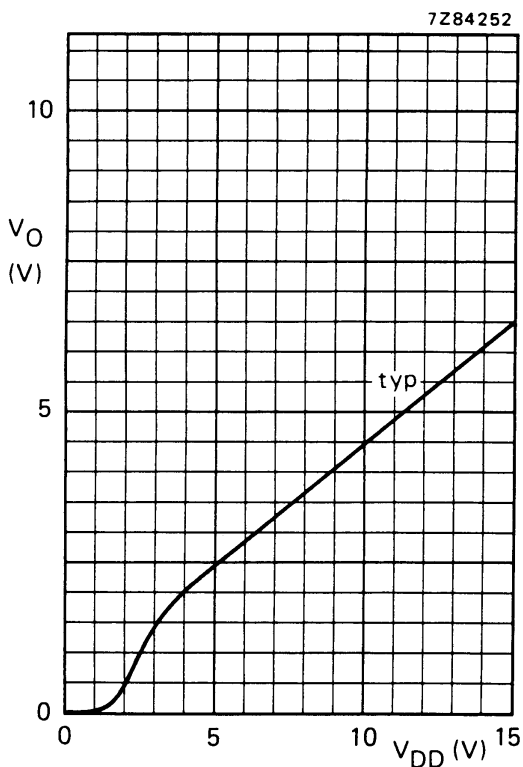

Fig.11 Output voltages as a function of supply voltage.

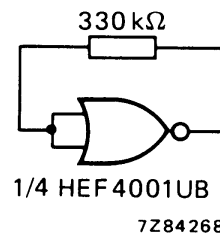

Fig.12 Test set-up for measuring graph of Fig.11.
Condition: all other inputs connected to ground.

NOTES

If a gate is just used as an amplifying inverter, there are two possibilities:

1. Connecting the inputs together gives simpler wiring, but makes the device output not completely symmetrical.
2. Connecting one input to V_{SS} will give the device a symmetrical output.

Quadruple 2-input NOR gate

HEF4001UB
gates

