

DATA SHEET

For a complete data sheet, please also download:

- The IC04 LOCMOS HE4000B Logic Family Specifications HEF, HEC
- The IC04 LOCMOS HE4000B Logic Package Outlines/Information HEF, HEC

HEF4502B **buffers** Strobed hex inverter/buffer

Product specification
File under Integrated Circuits, IC04

January 1995

Strobed hex inverter/buffer

HEF4502B buffers

DESCRIPTION

The HEF4502B consists of six inverter/buffers with 3-state outputs. When the output enable input (\overline{EO}) is HIGH all six outputs (O_1 to O_6) are in the high impedance OFF-state. When the enable input (\overline{E}) is HIGH all six outputs are switched to LOW. The outputs have a 2-TTL load drive capability.

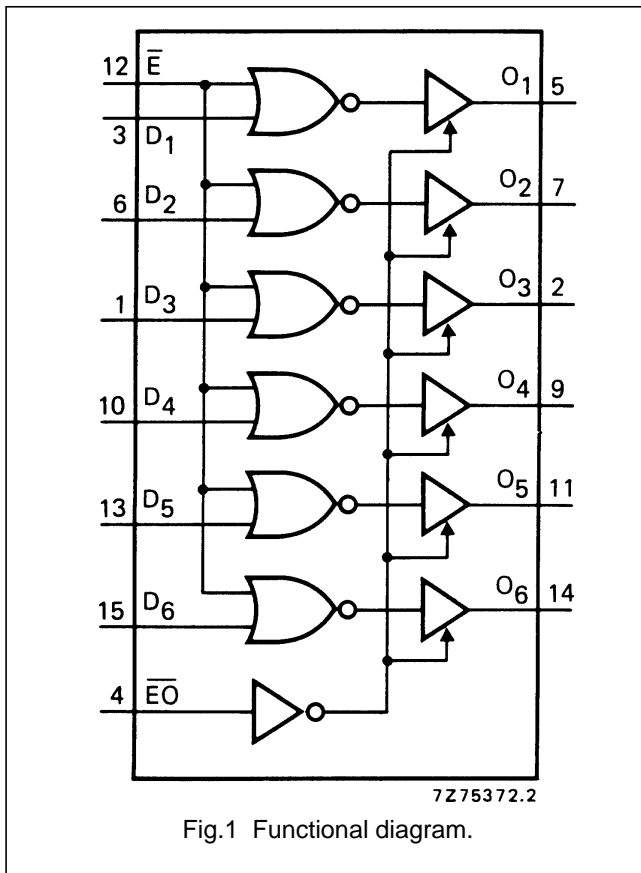

Fig.1 Functional diagram.

TRUTH TABLE

INPUTS			OUTPUT
D_n	\overline{E}	\overline{EO}	O_n
L	L	L	H
H	L	L	L
X	H	L	L
X	X	H	Z

Notes

- H = HIGH state (the more pos. voltage)
L = LOW state (the less pos. voltage)
X = state is immaterial
Z = high impedance off state

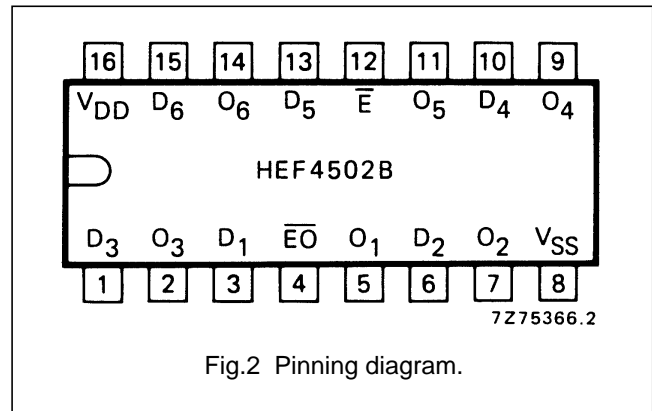

- HEF4502BP(N): 16-lead DIL; plastic (SOT38-1)
- HEF4502BD(F): 16-lead DIL; ceramic (cerdip) (SOT74)
- HEF4502BT(D): 16-lead SO; plastic (SOT109-1)
- (): Package Designator North America

PINNING

- D_1 to D_6 data inputs
- \overline{E} enable input
- \overline{EO} output enable input
- O_1 to O_6 3-state outputs

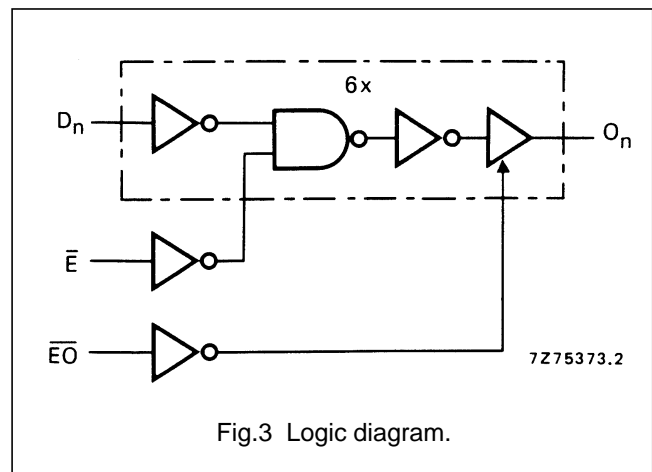

FAMILY DATA, I_{DD} LIMITS category BUFFERS

See Family Specifications

Strobed hex inverter/buffer

HEF4502B
buffers

DC CHARACTERISTICS

V_{SS} = 0 V

	V _{DD} V	V _{OH} V	V _{OL} V	SYMBOL	T _{amb} (°C)					
					-40		+ 25		+ 85	
					MIN.	MAX.	MIN.	MAX.	MIN.	MAX.
Output current HIGH	5	4,6		-I _{OH}	1,2		1,0		0,8	mA
	10	9,5			3,8		3,2		2,5	mA
	15	13,5			12,0		10,0		8,0	mA
Output current HIGH	5	2,5		-I _{OH}	3,8		3,2		2,5	mA
Output current LOW	4,75		0,4	I _{OL}	3,5		2,9		2,3	mA
	10		0,5		12,0		10,0		8,0	mA
	15		1,5		24,0		20,0		16,0	mA

AC CHARACTERISTICS

V_{SS} = 0 V; T_{amb} = 25 °C; input transition times ≤ 20 ns

	V _{DD} V	TYPICAL FORMULA FOR P (μW)	
Dynamic power dissipation per package (P)	5	$5\ 000 f_i + \sum (f_o C_L) \times V_{DD}^2$	where f _i = input freq. (MHz) f _o = output freq. (MHz) C _L = load capacitance (pF) ∑ (f _o C _L) = sum of outputs V _{DD} = supply voltage (V)
	10	$25\ 000 f_i + \sum (f_o C_L) \times V_{DD}^2$	
	15	$85\ 000 f_i + \sum (f_o C_L) \times V_{DD}^2$	

Strobed hex inverter/buffer

HEF4502B
buffers**AC CHARACTERISTICS** $V_{SS} = 0$ V; $T_{amb} = 25$ °C; $C_L = 50$ pF; input transition times ≤ 20 ns

	V_{DD} V	SYMBOL	TYP.	MAX.	TYPICAL EXTRAPOLATION FORMULA	
Propagation delays $D_n, \bar{E} \rightarrow O_n$ HIGH to LOW	5	t_{PHL}	85	170 ns	$77 \text{ ns} + (0,17 \text{ ns/pF}) C_L$	
	10		40	80 ns	$37 \text{ ns} + (0,06 \text{ ns/pF}) C_L$	
	15		35	70 ns	$33 \text{ ns} + (0,04 \text{ ns/pF}) C_L$	
	LOW to HIGH	5	t_{PLH}	80	160 ns	$66 \text{ ns} + (0,28 \text{ ns/pF}) C_L$
		10		35	70 ns	$28 \text{ ns} + (0,13 \text{ ns/pF}) C_L$
		15		30	60 ns	$25 \text{ ns} + (0,10 \text{ ns/pF}) C_L$
Output transition times HIGH to LOW	5	t_{THL}	25	50 ns	$10 \text{ ns} + (0,30 \text{ ns/pF}) C_L$	
	10		12	24 ns	$7 \text{ ns} + (0,11 \text{ ns/pF}) C_L$	
	15		8	15 ns	$5 \text{ ns} + (0,07 \text{ ns/pF}) C_L$	
	LOW to HIGH	5	t_{TLH}	30	60 ns	$5 \text{ ns} + (0,50 \text{ ns/pF}) C_L$
		10		15	30 ns	$3 \text{ ns} + (0,24 \text{ ns/pF}) C_L$
		15		12	24 ns	$3 \text{ ns} + (0,18 \text{ ns/pF}) C_L$
3-state propagation delays Output disable times $\bar{E}O \rightarrow O_n$ HIGH	5	t_{PHZ}	60	160 ns		
	10		55	140 ns		
	15		55	140 ns		
	LOW	5	t_{PLZ}	50		100 ns
		10		35		70 ns
		15		30		60 ns
Output enable times $\bar{E}O \rightarrow O_n$ HIGH	5	t_{PZH}	60	120 ns		
	10		35	70 ns		
	15		30	60 ns		
	LOW	5	t_{PZL}	55	110 ns	
		10		25	50 ns	
		15		20	40 ns	