

DATA SHEET

For a complete data sheet, please also download:

- The IC04 LOCMOS HE4000B Logic Family Specifications HEF, HEC
- The IC04 LOCMOS HE4000B Logic Package Outlines/Information HEF, HEC

HEF4557B

LSI

1-to-64 bit variable length shift register

Product specification
File under Integrated Circuits, IC04

January 1995

1-to-64 bit variable length shift register

HEF4557B LSI

DESCRIPTION

The HEF4557B is a static clocked serial shift register whose length may be programmed to be any number of bits between 1 and 64. The number of bits selected is equal to the sum of the subscripts of the enabled length control inputs ($L_1, L_2, L_4, L_8, L_{16}$ and L_{32}) plus one. Serial data may be selected from the D_A or D_B data inputs with the A/\bar{B} select input. This feature is useful for recirculation

purposes. Information on D_A or D_B is shifted into the first register position and all the data in the register is shifted one position to the right on the LOW to HIGH transition of CP_0 while $\overline{CP_1}$ is LOW or on the HIGH to LOW transition of $\overline{CP_1}$ while CP_0 is HIGH. A HIGH on master reset (MR) resets the register and forces O to LOW and \bar{O} to HIGH, independent of the other inputs.

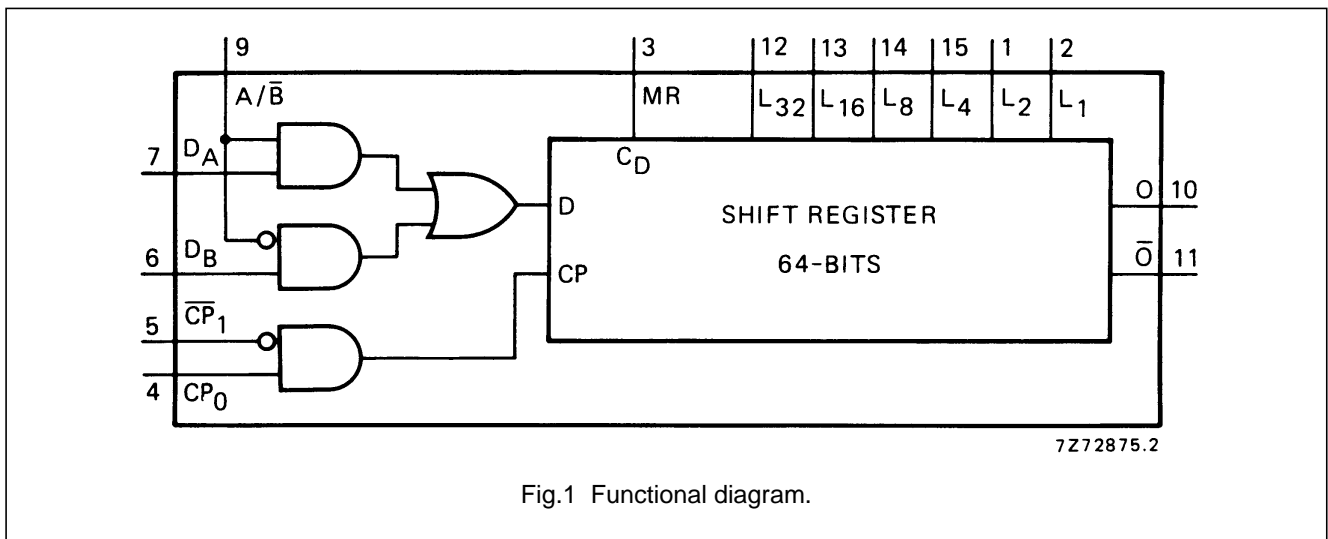

Fig.1 Functional diagram.

PINNING

- D_A, D_B data inputs
- A/\bar{B} select data input
- CP_0 clock input
- $\overline{CP_1}$ clock enable input
- MR asynchronous master reset
- L_1 to L_{32} bit-length control inputs
- O, \bar{O} buffered outputs

- HEF4557BP(N): 16-lead DIL; plastic (SOT38-1)
- HEF4557BD(F): 16-lead DIL; ceramic (cerdip) (SOT74)
- HEF4557BT(D): 16-lead SO; plastic (SOT109-1)
- (): Package Designator North America

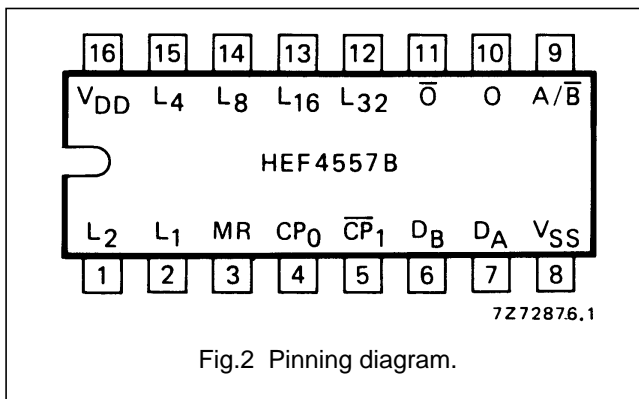

Fig.2 Pinning diagram.

FAMILY DATA, I_{DD} LIMITS category LSI

See Family Specifications

1-to-64 bit variable length shift register

HEF4557B
LSI

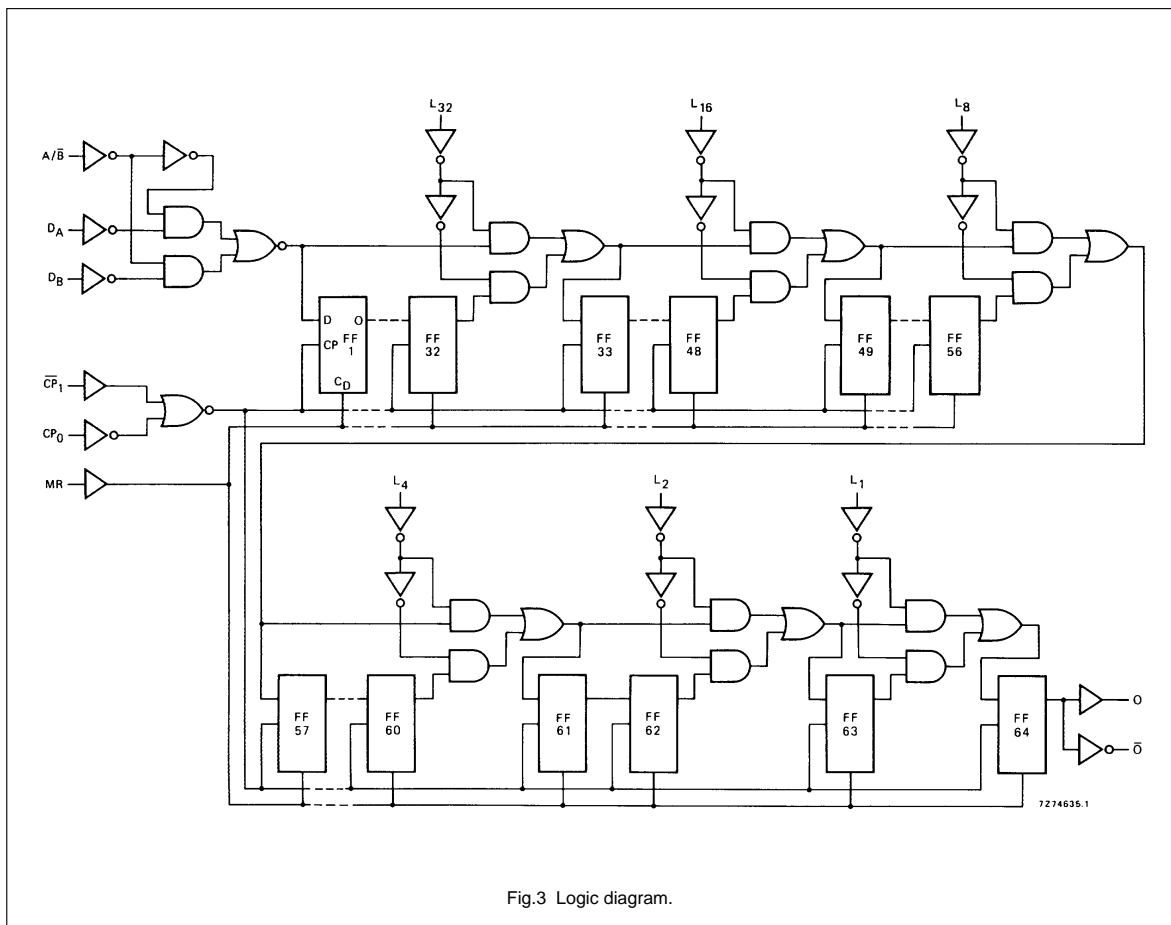

Fig.3 Logic diagram.

1-to-64 bit variable length shift register

HEF4557B
LSI

FUNCTION TABLE

INPUTS						OUTPUT
MR	A/B	D _A	D _B	CP _O	CP ₁	O ⁽¹⁾
L	L	D ₁	D ₂	↗	L	D ₂
L	H	D ₁	D ₂	↗	L	D ₁
L	L	D ₁	D ₂	H	↘	D ₂
L	H	D ₁	D ₂	H	↘	D ₁
H	X	X	X	X	X	L

Notes

1. The moment D_n appears at O depends on the bit-length shown in the table below.
2. H = HIGH state (the more positive voltage)
3. L = LOW state (the less positive voltage)
4. X = state is immaterial
5. ↗ = positive-going transition
6. ↘ = negative-going transition
7. D_n = either HIGH or LOW

BIT-LENGTH SELECT FUNCTION TABLE

L ₃₂	L ₁₆	L ₈	L ₄	L ₂	L ₁	REGISTER LENGTH
L	L	L	L	L	L	1-bit
L	L	L	L	L	H	2-bits
L	L	L	L	H	L	3-bits
L	L	L	L	H	H	4-bits
L	L	L	H	L	L	5-bits
L	L	L	H	L	H	6-bits
L	L	L	H	H	L	7-bits
L	L	L	H	H	H	8-bits
↓	↓	↓	↓	↓	↓	↓
L	H	H	H	H	H	32-bits
H	L	L	L	L	L	33-bits
H	L	L	L	L	H	34-bits
↓	↓	↓	↓	↓	↓	↓
H	H	H	H	L	L	61-bits
H	H	H	H	L	H	62-bits
H	H	H	H	H	L	63-bits
H	H	H	H	H	H	64-bits

AC CHARACTERISTICS

V_{SS} = 0 V; T_{amb} = 25 °C; input transition times ≤ 20 ns

	V _{DD} V	TYPICAL FORMULA FOR P (μW)	
Dynamic power dissipation per package (P)	5 10 15	3 500 f _i + ∑ (f _o C _L) × V _{DD} ² 15 000 f _i + ∑ (f _o C _L) × V _{DD} ² 37 000 f _i + ∑ (f _o C _L) × V _{DD} ²	where f _i = input freq. (MHz) f _o = output freq. (MHz) C _L = load capacitance (pF) ∑ (f _o C _L) = sum of outputs V _{DD} = supply voltage (V)

1-to-64 bit variable length shift register

HEF4557B
LSI

AC CHARACTERISTICS

$V_{SS} = 0\text{ V}$; $T_{amb} = 25\text{ }^\circ\text{C}$; $C_L = 50\text{ pF}$; input transition times $\leq 20\text{ ns}$

	V_{DD} V	SYMBOL	TYP.	MAX.		TYPICAL EXTRAPOLATION FORMULA	
Propagation delays $CP_0, \overline{CP}_1 \rightarrow O, \overline{O}$ HIGH to LOW	5	t_{PHL}	240	480	ns	$213\text{ ns} + (0,55\text{ ns/pF}) C_L$	
	10		90	180	ns	$79\text{ ns} + (0,23\text{ ns/pF}) C_L$	
	15		65	130	ns	$57\text{ ns} + (0,16\text{ ns/pF}) C_L$	
	LOW to HIGH	5	t_{PLH}	240	480	ns	$213\text{ ns} + (0,55\text{ ns/pF}) C_L$
		10		90	180	ns	$79\text{ ns} + (0,23\text{ ns/pF}) C_L$
		15		65	130	ns	$57\text{ ns} + (0,16\text{ ns/pF}) C_L$
	$MR \rightarrow O$ HIGH to LOW	5	t_{PHL}	170	340	ns	$143\text{ ns} + (0,55\text{ ns/pF}) C_L$
		10		80	160	ns	$69\text{ ns} + (0,23\text{ ns/pF}) C_L$
		15		60	120	ns	$52\text{ ns} + (0,16\text{ ns/pF}) C_L$
	$MR \rightarrow \overline{O}$ LOW to HIGH	5	t_{PLH}	140	280	ns	$113\text{ ns} + (0,55\text{ ns/pF}) C_L$
		10		70	140	ns	$59\text{ ns} + (0,23\text{ ns/pF}) C_L$
		15		55	110	ns	$47\text{ ns} + (0,16\text{ ns/pF}) C_L$
Output transition times HIGH to LOW	5	t_{THL}	60	120	ns	$10\text{ ns} + (1,0\text{ ns/pF}) C_L$	
	10		30	60	ns	$9\text{ ns} + (0,42\text{ ns/pF}) C_L$	
	15		20	40	ns	$6\text{ ns} + (0,28\text{ ns/pF}) C_L$	
	LOW to HIGH	5	t_{TLH}	60	120	ns	$10\text{ ns} + (1,0\text{ ns/pF}) C_L$
		10		30	60	ns	$9\text{ ns} + (0,42\text{ ns/pF}) C_L$
		15		20	40	ns	$6\text{ ns} + (0,28\text{ ns/pF}) C_L$

Interpolation table (see note next page)

LENGTH CONTROL INPUTS						MINIMUM NUMBER OF BITS SELECTED	SET-UP, HOLD, RECOVERY TIMES
L_1	L_2	L_4	L_8	L_{16}	L_{32}		
L	L	L	L	L	L	1	specified
H	L	L	L	L	L	2	
X	H	L	L	L	L	3	
X	X	H	L	L	L	5	six equal steps
X	X	X	H	L	L	9	
X	X	X	X	H	L	17	
X	X	X	X	X	H	33	specified

Notes

1. H = HIGH state (the more positive voltage)
2. L = LOW state (the less positive voltage)
3. X = state is immaterial

1-to-64 bit variable length shift register

HEF4557B
LSI**AC CHARACTERISTICS** $V_{SS} = 0$ V; $T_{amb} = 25$ °C; $C_L = 50$ pF; input transition times ≤ 20 ns; see also waveforms Fig.4

	V_{DD} V	SYMBOL	MIN.	TYP.		
Minimum clock pulse width; LOW for CP_0 or HIGH for \overline{CP}_1	5	t_{WCPL}	180	90 ns	see note	
	10	or	60	30 ns		
	15	t_{WCPH}	40	20 ns		
Minimum reset pulse width; HIGH	5	t_{WMRH}	150	75 ns		
	10		70	35 ns		
	15		50	25 ns		
Set-up times $D_A, D_B, A/\overline{B} \rightarrow CP_0,$ \overline{CP}_1 L_1 to $L_{32} = \text{LOW}$	5	t_{su}	360	180 ns		
	10		140	70 ns		
	15		90	45 ns		
	$L_{32} = \text{HIGH}$	5	t_{su}	40		-20 ns
		10		35		-10 ns
		15		30		-5 ns
Hold times $D_A, D_B, A/\overline{B} \rightarrow CP_0,$ \overline{CP}_1 L_1 to $L_{32} = \text{LOW}$	5	t_{hold}	-40	-110 ns		
	10		-10	-45 ns		
	15		0	-30 ns		
	$L_{32} = \text{HIGH}$	5	t_{hold}	90	30 ns	
		10		60	20 ns	
		15		50	15 ns	
Recovery times for MR L_1 to $L_{32} = \text{LOW}$	5	t_{RMR}	500	250 ns		
	10		250	125 ns		
	15		150	75 ns		
	$L_{32} = \text{HIGH}$	5	t_{RMR}	110	50 ns	
		10		70	30 ns	
		15		60	25 ns	
Minimum clock pulse frequency	5	f_{max}	2,5	5 MHz		
	10		7	14 MHz		
	15		10	20 MHz		

Note

1. The set-up, hold and recovery times vary with the minimum number of bits selected. For other values as specified one may interpolate as shown in the table (see previous page).

1-to-64 bit variable length shift register

HEF4557B
LSI

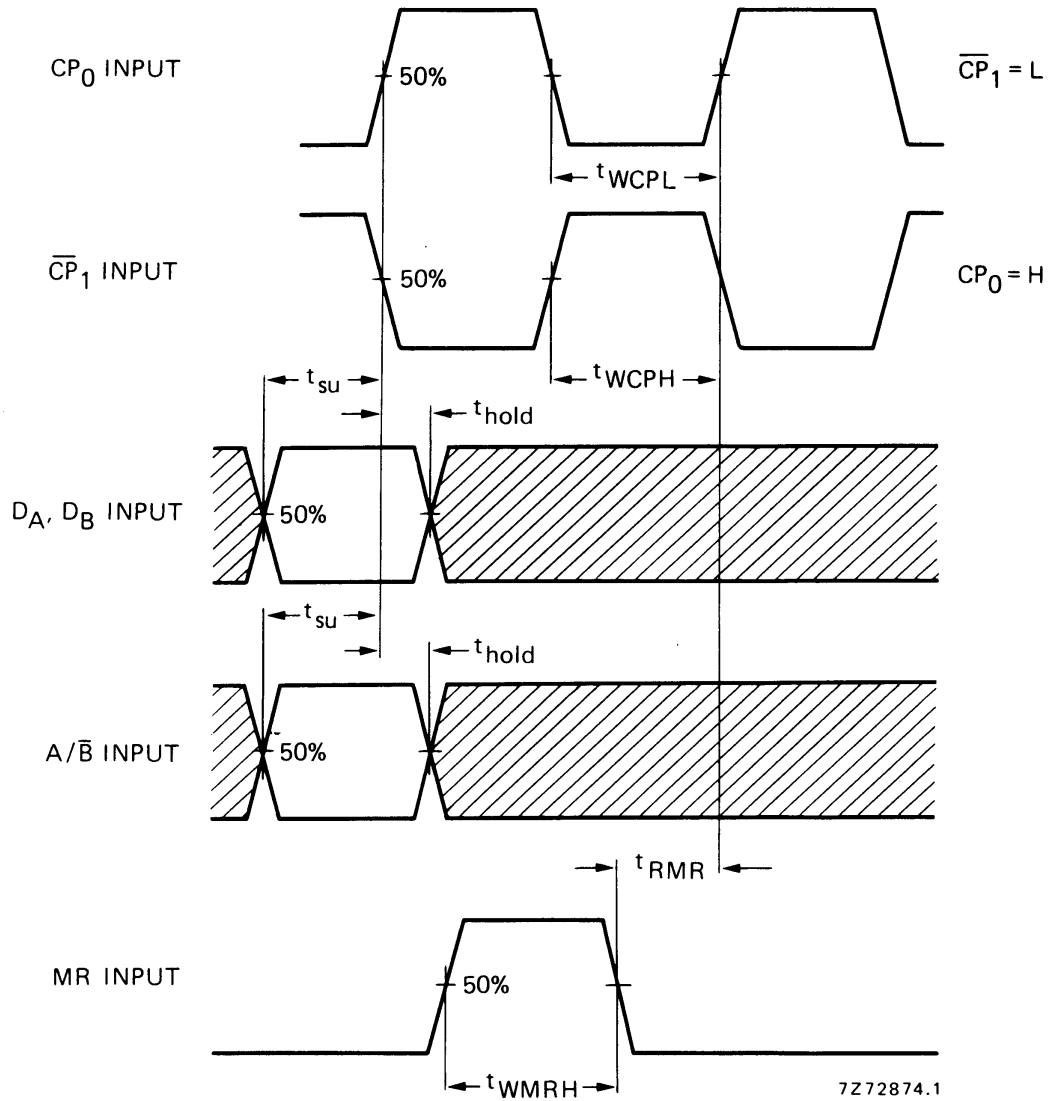

Fig.4 Waveforms showing recovery time for MR and minimum CP_0 , \overline{CP}_1 and MR pulse widths, set-up and hold times for D_A , D_B and A/\overline{B} to CP_0 and \overline{CP}_1 . Set-up and hold times are shown as positive values but may be specified as negative values.