

DATA SHEET

For a complete data sheet, please also download:

- The IC04 LOCMOS HE4000B Logic Family Specifications HEF, HEC
- The IC04 LOCMOS HE4000B Logic Package Outlines/Information HEF, HEC

HEF4585B

MSI

4-bit magnitude comparator

Product specification
File under Integrated Circuits, IC04

January 1995

4-bit magnitude comparator

HEF4585B MSI

DESCRIPTION

The HEF4585B is a 4-bit magnitude comparator which compares two 4-bit words (A and B), whether they are 'less than', 'equal to', or 'greater than'. Each word has four parallel inputs (A_0 to A_3 and B_0 to B_3); A_3 and B_3 being the most significant inputs. Three outputs are provided; A greater than B ($O_{A>B}$), A less than B ($O_{A<B}$) and A equal to B ($O_{A=B}$). Three expander inputs ($I_{A>B}$, $I_{A<B}$ and $I_{A=B}$) allow cascading of the devices without external gates.

For proper compare operation the expander inputs to the least significant position must be connected as follows: $I_{A=B} = I_{A>B} = \text{HIGH}$, $I_{A<B} = \text{LOW}$. For words greater than 4-bits, units can be cascaded by connecting outputs $O_{A<B}$ and $O_{A=B}$ to the corresponding inputs of the next significant comparator (input $I_{A>B}$ is connected to a HIGH).

Operation is not restricted to binary codes, the devices will work with any monotonic code. The function table describes the operation of the device under all possible logic conditions.

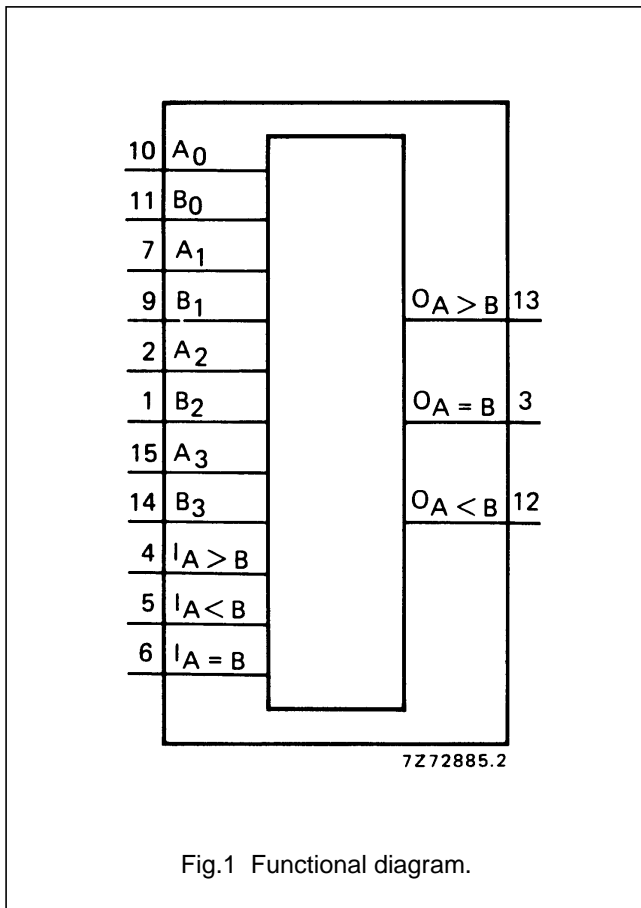

Fig.1 Functional diagram.

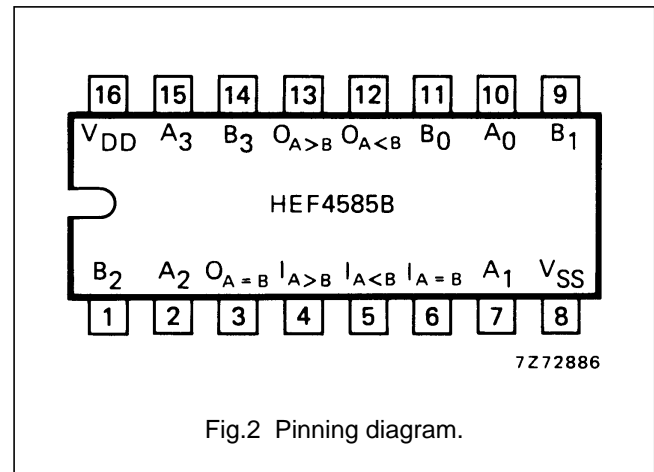

Fig.2 Pinning diagram.

- HEF4585BP(N): 16-lead DIL; plastic (SOT38-1)
- HEF4585BD(F): 16-lead DIL; ceramic (cerdip) (SOT74)
- HEF4585BT(D): 16-lead SO; plastic (SOT109-1)
- (): Package Designator North America

PINNING

- A_0 to A_3 word A parallel inputs
- B_0 to B_3 word B parallel inputs
- $I_{A>B}$, $I_{A<B}$, $I_{A=B}$ expander inputs
- $O_{A>B}$ A greater than B output
- $O_{A<B}$ A less than B output
- $O_{A=B}$ A equal to B output

FAMILY DATA, I_{DD} LIMITS category MSI

See Family Specifications

4-bit magnitude comparator

HEF4585B
MSI

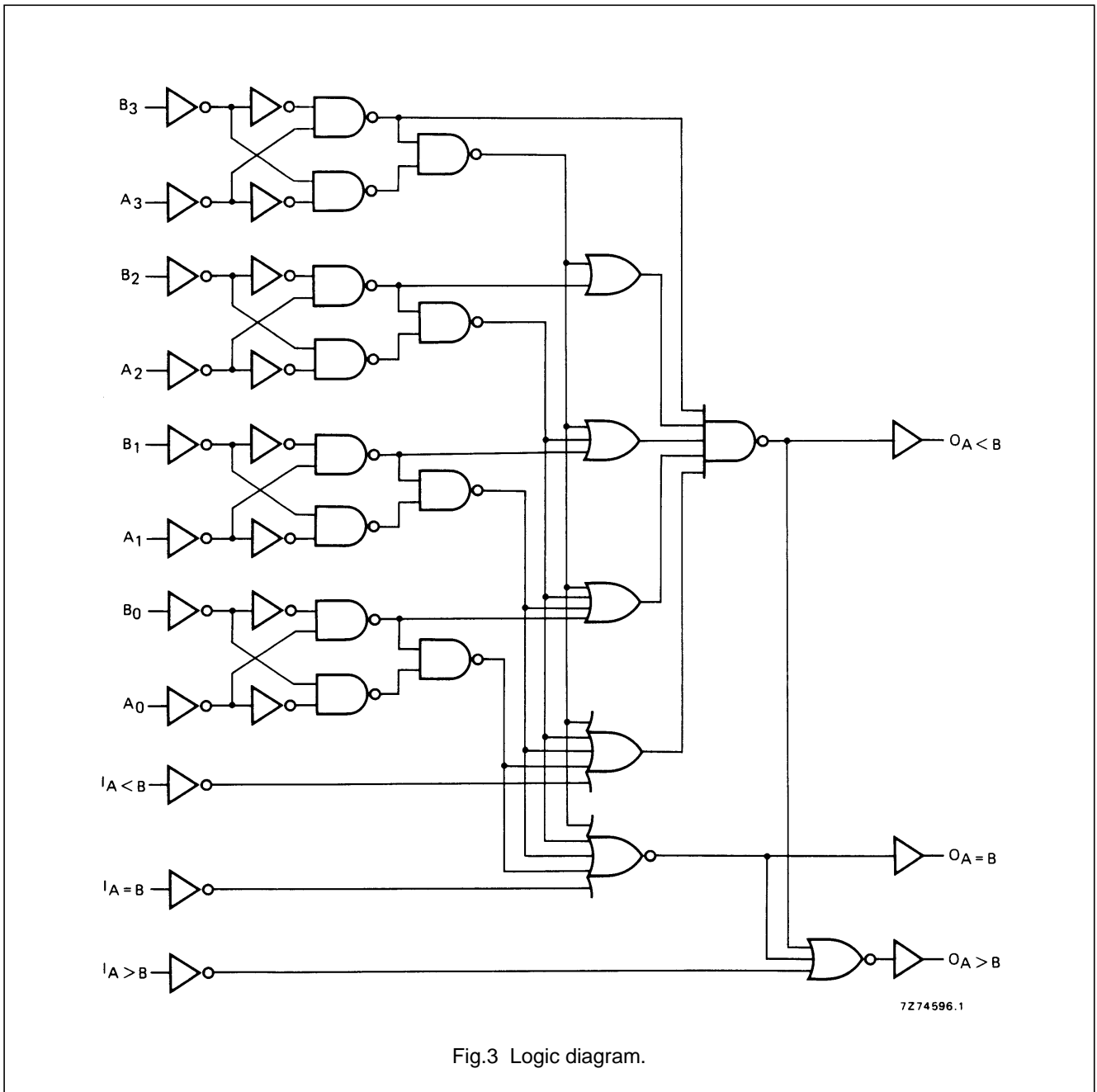

Fig.3 Logic diagram.

4-bit magnitude comparator

HEF4585B
MSI

FUNCTION TABLE

COMPARING INPUTS				CASCADING INPUTS			OUTPUTS		
A ₃ , B ₃	A ₂ , B ₂	A ₁ , B ₁	A ₀ , B ₀	I _{A > B}	I _{A < B}	I _{A = B}	O _{A > B}	O _{A < B}	O _{A = B}
A ₃ > B ₃	X	X	X	H	X	X	H	L	L
A ₃ < B ₃	X	X	X	X	X	X	L	H	L
A ₃ = B ₃	A ₂ > B ₂	X	X	H	X	X	H	L	L
A ₃ = B ₃	A ₂ < B ₂	X	X	X	X	X	L	H	L
A ₃ = B ₃	A ₂ = B ₂	A ₁ > B ₁	X	H	X	X	H	L	L
A ₃ = B ₃	A ₂ = B ₂	A ₁ < B ₁	X	X	X	X	L	H	L
A ₃ = B ₃	A ₂ = B ₂	A ₁ = B ₁	A ₀ > B ₀	H	X	X	H	L	L
A ₃ = B ₃	A ₂ = B ₂	A ₁ = B ₁	A ₀ < B ₀	X	X	X	L	H	L
A ₃ = B ₃	A ₂ = B ₂	A ₁ = B ₁	A ₀ = B ₀	X	L	H	L	L	H
A ₃ = B ₃	A ₂ = B ₂	A ₁ = B ₁	A ₀ = B ₀	H	L	L	H	L	L
A ₃ = B ₃	A ₂ = B ₂	A ₁ = B ₁	A ₀ = B ₀	X	H	L	L	H	L
A ₃ = B ₃	A ₂ = B ₂	A ₁ = B ₁	A ₀ = B ₀	X	H	H	L	H	H
A ₃ = B ₃	A ₂ = B ₂	A ₁ = B ₁	A ₀ = B ₀	L	L	L	L	L	L

Notes

- 1. H = HIGH state (the more positive voltage)
- L = LOW state (the less positive voltage)
- X = state is immaterial

The upper 11 lines describe the normal operation under all conditions that will occur in a single device or in a serial expansion scheme.

The lower 2 lines describe the operation under abnormal conditions on the cascading inputs. These conditions occur when the parallel expansion technique is used.

4-bit magnitude comparator

HEF4585B
MSI**AC CHARACTERISTICS** $V_{SS} = 0\text{ V}$; $T_{amb} = 25\text{ }^{\circ}\text{C}$; $C_L = 50\text{ pF}$; input transition times $\leq 20\text{ ns}$

	V_{DD} V	SYMBOL	MIN.	TYP.	MAX.	TYPICAL EXTRAPOLATION FORMULA			
Propagation delays	5	t_{PHL}			ns	$A_n, B_n \rightarrow O_n$			
						HIGH to LOW			
						10	160	320	$133\text{ ns} + (0,55\text{ ns/pF}) C_L$
	15					65	130	$54\text{ ns} + (0,23\text{ ns/pF}) C_L$	
	5					150	300	$123\text{ ns} + (0,55\text{ ns/pF}) C_L$	
	10					60	120	$49\text{ ns} + (0,23\text{ ns/pF}) C_L$	
	15	45	90	$37\text{ ns} + (0,16\text{ ns/pF}) C_L$					
	LOW to HIGH	5	t_{PLH}		ns	$I_n \rightarrow O_n$			
						HIGH to LOW			
						10	110	220	$83\text{ ns} + (0,55\text{ ns/pF}) C_L$
	15	45				90	$34\text{ ns} + (0,23\text{ ns/pF}) C_L$		
	5	120				240	$93\text{ ns} + (0,55\text{ ns/pF}) C_L$		
10	50	100				$39\text{ ns} + (0,23\text{ ns/pF}) C_L$			
15	30	60	$22\text{ ns} + (0,16\text{ ns/pF}) C_L$						
Output transition times	5	t_{THL}		ns	HIGH to LOW				
					10	60	120	$10\text{ ns} + (1,0\text{ ns/pF}) C_L$	
					15	30	60	$9\text{ ns} + (0,42\text{ ns/pF}) C_L$	
	LOW to HIGH	5	t_{TLH}		ns	HIGH to LOW			
						10	60	120	$10\text{ ns} + (1,0\text{ ns/pF}) C_L$
						15	20	40	$6\text{ ns} + (0,28\text{ ns/pF}) C_L$
5	60	120				$10\text{ ns} + (1,0\text{ ns/pF}) C_L$			
10	30	60				$9\text{ ns} + (0,42\text{ ns/pF}) C_L$			
15	20	40				$6\text{ ns} + (0,28\text{ ns/pF}) C_L$			

	V_{DD} V	TYPICAL FORMULA FOR P (μW)	
Dynamic power dissipation per package (P)	5	$1250 f_i + \sum (f_o C_L) \times V_{DD}^2$	where f_i = input freq. (MHz) f_o = output freq. (MHz) C_L = load capacitance (pF) $\sum (f_o C_L)$ = sum of outputs V_{DD} = supply voltage (V)
	10	$5500 f_i + \sum (f_o C_L) \times V_{DD}^2$	
	15	$15\ 000 f_i + \sum (f_o C_L) \times V_{DD}^2$	

APPLICATION INFORMATION

Some examples of applications for the HEF4585B are:

- Process controllers.
- Servo-motor control.

4-bit magnitude comparator

HEF4585B
MSI

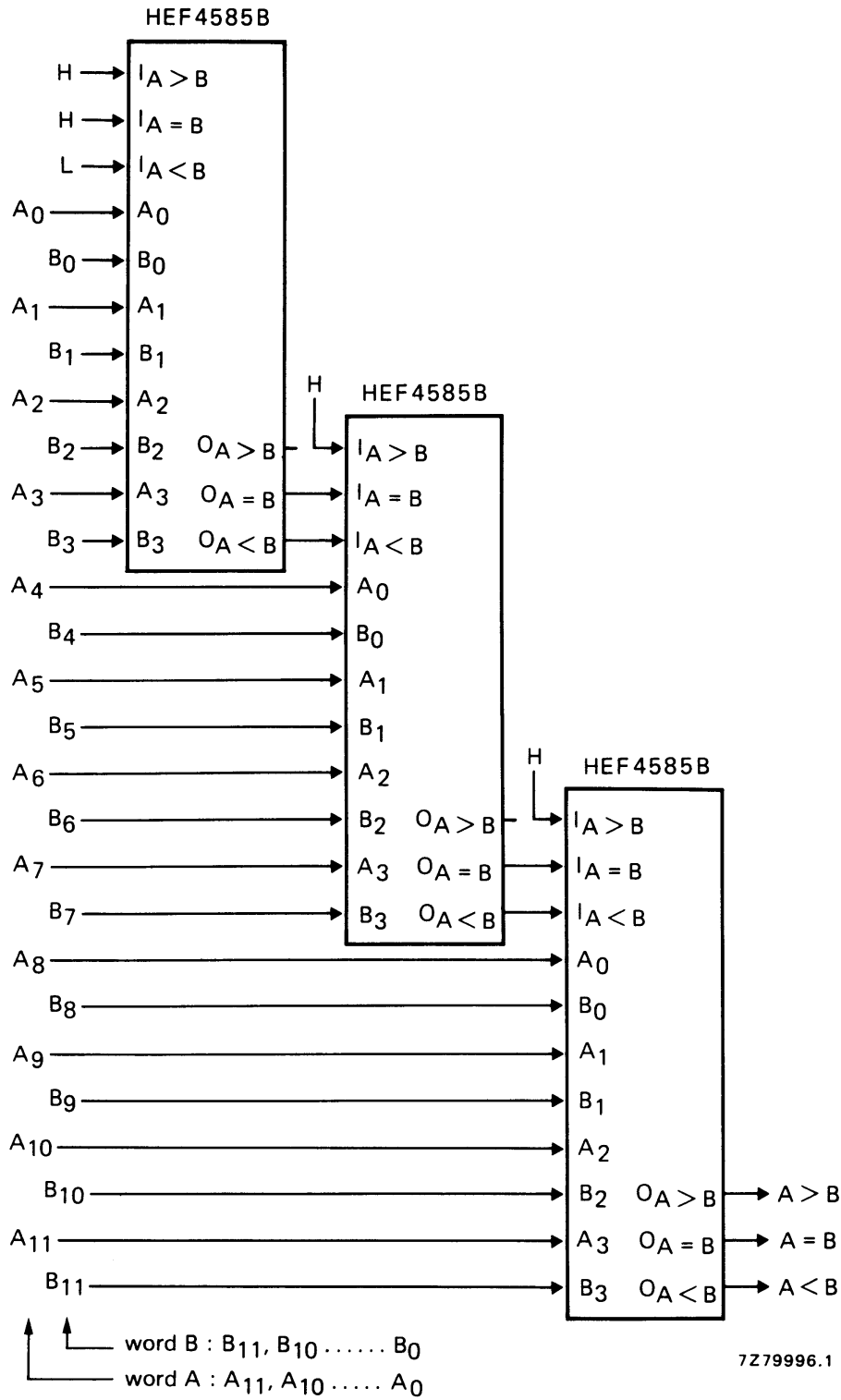

Fig.4 Example of cascading comparators.