

# DATA SHEET

## **74ALS573B/74ALS574A** Latch flip-flop

Product specification  
IC05 Data Handbook

1991 Feb 08

## Latch/flip-flop

## 74ALS573B/74ALS574A

74ALS573B Octal transparent latch (3-State)  
74ALS574A Octal D flip-flop (3-State)

## FEATURES

- 74ALS573B is broadside pinout version of 74ALS373
- 74ALS574A is broadside pinout version of 74ALS374
- Inputs and outputs on opposite side of package allow easy interface to microprocessors
- Useful as an input or output port for microprocessors
- 3-State outputs for bus interfacing
- Common output enable
- 74ALS563A and 74ALS564A are inverting version of 74ALS573B and 74ALS574A respectively

## DESCRIPTION

The 74ALS573B is an octal transparent latch coupled to eight 3-State output devices. The two sections of the device are controlled independently by enable (E) and output enable ( $\overline{OE}$ ) control gates.

The 74ALS573B is functionally identical to the 74ALS373 but has a broadside pinout configuration to facilitate PC board layout and allow easy interface with microprocessors.

The data on the D inputs is transferred to the latch outputs when the enable (E) input is High. The latch remains transparent to the data input while E is High, and stores the data that is present one setup time before the High-to-Low enable transition.

The 74ALS574A is functionally identical to the 74ALS374 but has a broadside pinout configuration to facilitate PC board layout and allow easy interface with microprocessors.

It is an 8-bit edge triggered register coupled to eight 3-State output buffers. The two sections of the device are controlled independently by clock (CP) and output enable ( $\overline{OE}$ ) control gates.

The register is fully edge triggered. The state of the D input, one setup time before the Low-to-High clock transition is transferred to the corresponding flip-flop's Q output.

The active-Low output enable ( $\overline{OE}$ ) controls all eight 3-State buffers independent of the latch operation. When  $\overline{OE}$  is Low, latched or transparent data appears at the output.

When  $\overline{OE}$  is High, the outputs are in high impedance "off" state, which means they will neither drive nor load the bus.

TYPE	TYPICAL PROPAGATION DELAY	TYPICAL SUPPLY CURRENT (TOTAL)
74ALS573B	5.0ns	12mA
74ALS574A	6.0ns	15mA

## ORDERING INFORMATION

DESCRIPTION	ORDER CODE	DRAWING NUMBER
	COMMERCIAL RANGE $V_{CC} = 5V \pm 10\%$ , $T_{amb} = 0^{\circ}C$ to $+70^{\circ}C$	
20-pin plastic DIP	74ALS573BN, 74ALS574AN	SOT146-1
20-pin plastic SOL	74ALS573BD, 74ALS574AD	SOT163-1
20-pin plastic SSOP Type II	74ALS573BDB, 74ALS574ADB	SOT339-1

## INPUT AND OUTPUT LOADING AND FAN-OUT TABLE

PINS	DESCRIPTION	74ALS (U.L.) HIGH/LOW	LOAD VALUE HIGH/LOW
D0 – D7	Data inputs	1.0/1.0	20 $\mu$ A/0.2mA
E (74ALS573B)	Latch enable input	1.0/1.0	20 $\mu$ A/0.1mA
$\overline{OE}$	Output Enable input (active-Low)	1.0/1.0	20 $\mu$ A/0.1mA
CP (74ALS574A)	Clock pulse input (active rising edge)	1.0/2.0	20 $\mu$ A/0.2mA
Q0 – Q7	Data outputs	130/240	2.6mA/24mA

**NOTE:** One (1.0) ALS unit load is defined as: 20 $\mu$ A in the High state and 0.1mA in the Low state.

# Latch/flip-flop

# 74ALS573B/74ALS574A

## PIN CONFIGURATION – 74ALS573B

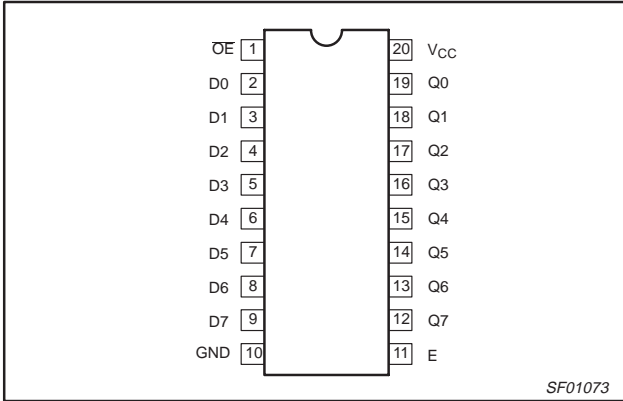

## PIN CONFIGURATION – 74ALS574A

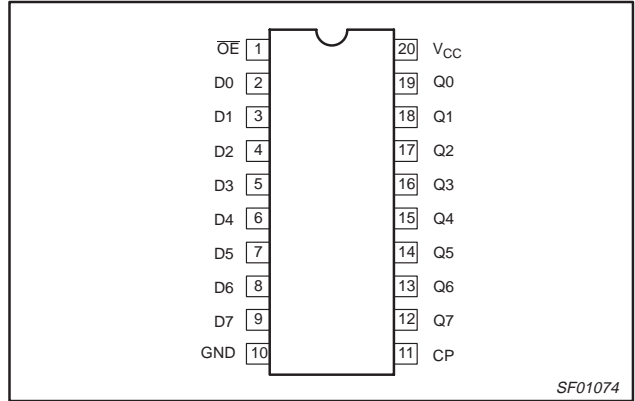

## LOGIC SYMBOL – 74ALS573B

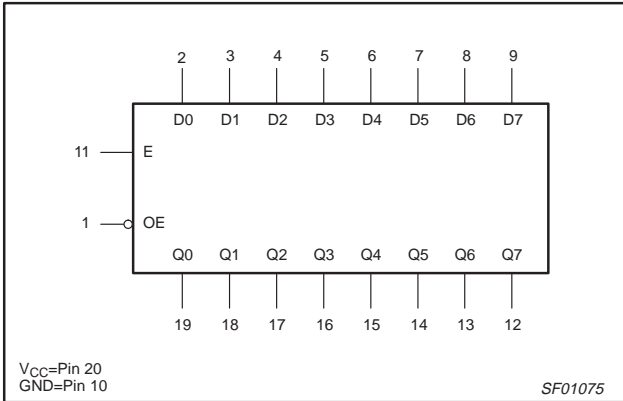

## LOGIC SYMBOL – 74ALS574A

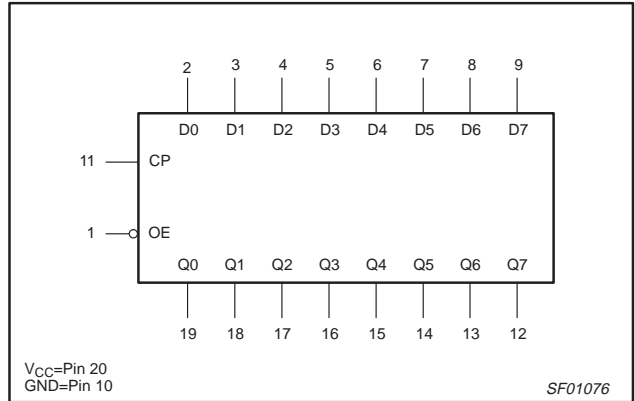

## IEC/IEEE SYMBOL – 74ALS573B

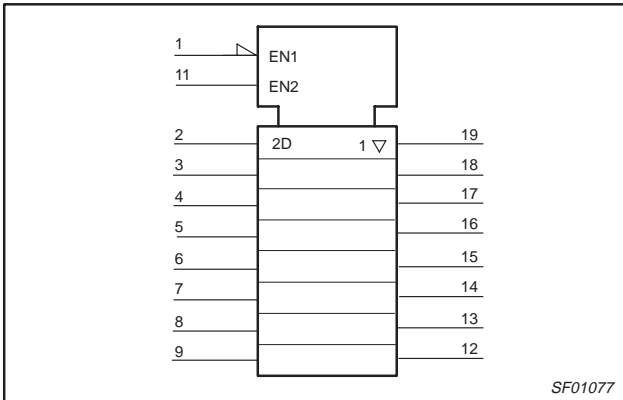

## IEC/IEEE SYMBOL – 74ALS574A

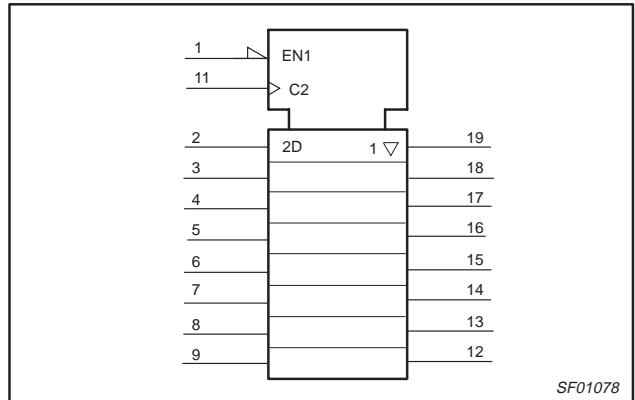

Latch/flip-flop

74ALS573B/74ALS574A

LOGIC DIAGRAM – 74ALS573B

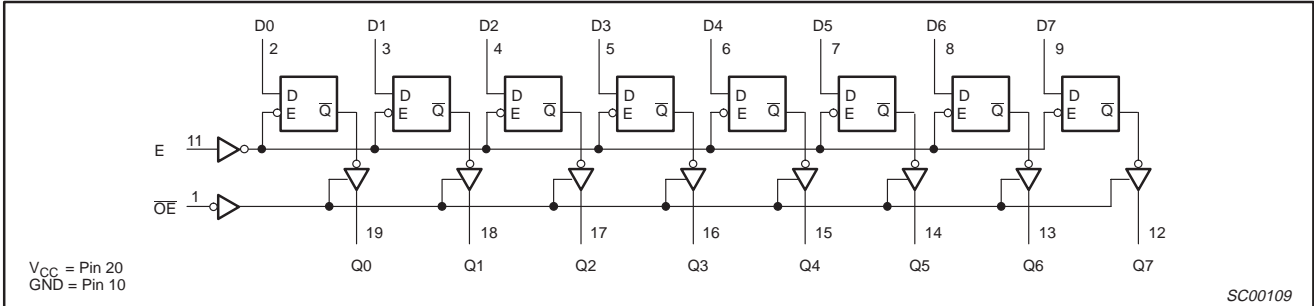

FUNCTION TABLE – 74ALS573B

INPUTS			OUTPUTS REGISTER	INTERNAL	OPERATING MODE
OE	E	Dn		Q0 – Q7	
L	H	L	L	L	Enable and read register
L	H	H	H	H	
L	↓	l	L	L	Latch and read register
L	↓	h	H	H	
L	L	X	NC	NC	Hold
H	L	X	NC	Z	Disable outputs
H	H	Dn	Dn	Z	

- H = High-voltage level
- h = High state must be present one setup time before the High-to-Low enable transition
- L = Low-voltage level
- l = Low state must be present one setup time before the High-to-Low enable transition
- NC= No change
- X = Don't care
- Z = High impedance "off" state
- ↓ = High-to-Low enable transition

LOGIC DIAGRAM – 74ALS574A

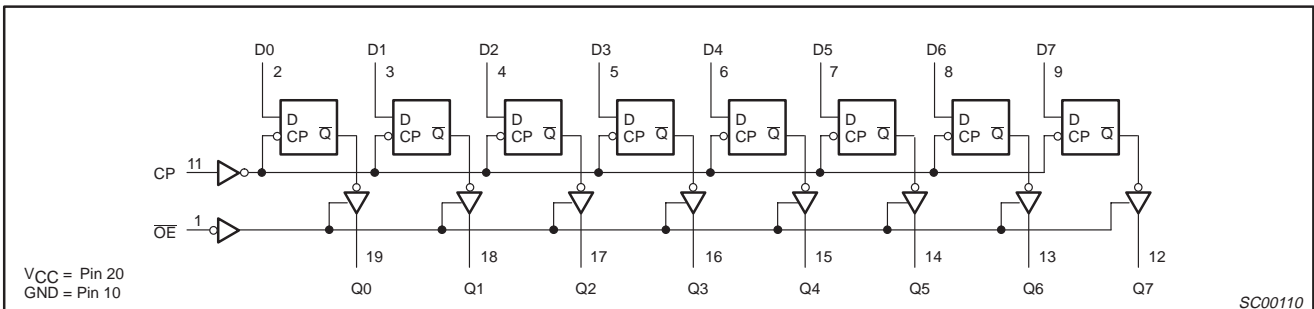

## Latch/flip-flop

## 74ALS573B/74ALS574A

FUNCTION TABLE – 74ALS574A

INPUTS			OUTPUTS REGISTER	INTERNAL	OPERATING MODE
$\overline{OE}$	CP	Dn		Q0 – Q7	
L	↑	l	L	L	Latch and read register
L	↑	h	H	H	
L	↑	X	NC	NC	Hold
H	↑	X	NC	Z	Disable outputs
H	↑	Dn	Dn	Z	

H = High-voltage level

h = High state must be present one setup time before the Low-to-High clock transition

L = Low-voltage level

l = Low state must be present one setup time before the Low-to-High clock transition

NC = No change

X = Don't care

Z = High impedance "off" state

↑ = Low-to-High clock transition

↑ = Not Low-to-High clock transition

## ABSOLUTE MAXIMUM RATINGS

(Operation beyond the limit set forth in this table may impair the useful life of the device.)

Unless otherwise noted these limits are over the operating free-air temperature range.)

SYMBOL	PARAMETER	RATING	UNIT
$V_{CC}$	Supply voltage	-0.5 to +7.0	V
$V_{IN}$	Input voltage	-0.5 to +7.0	V
$I_{IN}$	Input current	-30 to +5	mA
$V_{OUT}$	Voltage applied to output in High output state	-0.5 to $V_{CC}$	V
$I_{OUT}$	Current applied to output in Low output state	48	mA
$T_{amb}$	Operating free-air temperature range	0 to +70	°C
$T_{stg}$	Storage temperature range	-65 to +150	°C

## RECOMMENDED OPERATING CONDITIONS

SYMBOL	PARAMETER	LIMITS			UNIT
		MIN	NOM	MAX	
$V_{CC}$	Supply voltage	4.5	5.0	5.5	V
$V_{IH}$	High-level input voltage	2.0			V
$V_{IL}$	Low-level input voltage			0.8	V
$I_{IK}$	Input clamp current			-18	mA
$I_{OH}$	High-level output current			-2.6	mA
$I_{OL}$	Low-level output current			24	mA
$T_{amb}$	Operating free-air temperature range	0		+70	°C

## Latch/flip-flop

## 74ALS573B/74ALS574A

**DC ELECTRICAL CHARACTERISTICS**

(Over recommended operating free-air temperature range unless otherwise noted.)

SYMBOL	PARAMETER		TEST CONDITIONS <sup>1</sup>	LIMITS			UNIT	
				MIN	TYP <sup>2</sup>	MAX		
V <sub>OH</sub>	High-level output voltage		V <sub>CC</sub> = ±10%, V <sub>IL</sub> = MAX, V <sub>IH</sub> = MIN	I <sub>OH</sub> = -0.4mA	V <sub>CC</sub> - 2		V	
				I <sub>OH</sub> = MAX	2.4	3.2	V	
V <sub>OL</sub>	Low-level output voltage		V <sub>CC</sub> = MIN, V <sub>IL</sub> = MAX, V <sub>IH</sub> = MIN	I <sub>OL</sub> = 12mA		0.25	0.40	V
				I <sub>OL</sub> = 24mA		0.35	0.50	V
V <sub>IK</sub>	Input clamp voltage		V <sub>CC</sub> = MIN, I <sub>I</sub> = I <sub>IK</sub>		-0.73	-1.2	V	
I <sub>I</sub>	Input current at minimum input voltage		V <sub>CC</sub> = MAX, V <sub>I</sub> = 7.0V			0.1	mA	
I <sub>IH</sub>	High-level input current		V <sub>CC</sub> = MAX, V <sub>I</sub> = 2.7V			20	μA	
I <sub>IL</sub>	Low-level input current	74ALS573B	V <sub>CC</sub> = MAX, V <sub>I</sub> = 0.4V			-0.1	mA	
		74ALS574A	V <sub>CC</sub> = MAX, V <sub>I</sub> = 0.4V			-0.2	mA	
I <sub>OZH</sub>	Off-state output current, High-level voltage applied		V <sub>CC</sub> = MAX, V <sub>I</sub> = 2.7V			20	μA	
I <sub>OZL</sub>	Off-state output current, Low-level voltage applied		V <sub>CC</sub> = MAX, V <sub>I</sub> = 0.4V			-20	μA	
I <sub>O</sub>	Output current <sup>3</sup>		V <sub>CC</sub> = MAX, V <sub>O</sub> = 2.25V	-30		-112	mA	
I <sub>CC</sub>	Supply current (total)	74ALS573B	I <sub>CCH</sub>	V <sub>CC</sub> = MAX		7	12	mA
			I <sub>CCL</sub>			13	21	mA
			I <sub>CCZ</sub>			15	24	mA
		74ALS574A	I <sub>CCH</sub>			10	16	mA
			I <sub>CCL</sub>			17	27	mA
			I <sub>CCZ</sub>			18	28	mA

**NOTES:**

- For conditions shown as MIN or MAX, use the appropriate value specified under recommended operating conditions for the applicable type.
- All typical values are at V<sub>CC</sub> = 5V, T<sub>amb</sub> = 25°C.
- The output conditions have been chosen to produce a current that closely approximates one half of the true short-circuit output current, I<sub>OS</sub>.

## Latch/flip-flop

## 74ALS573B/74ALS574A

## AC ELECTRICAL CHARACTERISTICS

SYMBOL	PARAMETER		TEST CONDITION	LIMITS		UNIT
				$T_{amb} = 0^{\circ}\text{C to } +70^{\circ}\text{C}$ $V_{CC} = +5.0\text{V} \pm 10\%$ $C_L = 50\text{pF}, R_L = 500\Omega$		
				MIN	MAX	
$t_{PLH}$ $t_{PHL}$	Propagation delay Dn to Qn	74ALS573B	Waveform 3	2.0 2.0	10.0 10.0	ns
$t_{PLH}$ $t_{PHL}$	Propagation delay E to Qn		Waveform 2	4.0 4.0	12.0 12.0	ns
$t_{PZH}$ $t_{PZL}$	Output enable time to High or Low level		Waveform 6 Waveform 7	2.0 4.0	9.0 11.0	ns
$t_{PHZ}$ $t_{PLZ}$	Output disable time from High or Low level		Waveform 6 Waveform 7	1.0 2.0	9.0 11.0	ns
$f_{MAX}$	Maximum clock frequency	74ALS574A	Waveform 1	45		MHz
$t_{PLH}$ $t_{PHL}$	Propagation delay CP to Qn		Waveform 1	3.0 4.0	12.0 12.0	ns
$t_{PZH}$ $t_{PZL}$	Output enable time to High or Low level		Waveform 6 Waveform 7	2.0 4.0	9.0 11.0	ns
$t_{PHZ}$ $t_{PLZ}$	Output disable time from High or Low level		Waveform 6 Waveform 7	1.0 2.0	9.0 11.0	ns

## AC SETUP CHARACTERISTICS

SYMBOL	PARAMETER		TEST CONDITION	LIMITS		UNIT
				$T_{amb} = 0^{\circ}\text{C to } +70^{\circ}\text{C}$ $V_{CC} = +5.0\text{V} \pm 10\%$ $C_L = 50\text{pF}, R_L = 500\Omega$		
				MIN	MAX	
$t_{su(H)}$ $t_{su(L)}$	Setup time, High or Low Dn to E	74ALS573B	Waveform 4	6.0 6.0		ns
$t_h(H)$ $t_h(L)$	Hold time, High or Low Dn to E		Waveform 4	6.0 6.0		ns
$t_w(H)$	E Pulse width, High		Waveform 1	10.0		ns
$t_{su(H)}$ $t_{su(L)}$	Setup time, High or Low Dn to CP	74ALS574A	Waveform 5	6.0 6.0		ns
$t_h(H)$ $t_h(L)$	Hold time, High or Low Dn to CP		Waveform 5	1.0 1.0		ns
$t_w(H)$ $t_w(L)$	CP Pulse width, High or Low		Waveform 5	8.0 12.0		ns

# Latch/flip-flop

# 74ALS573B/74ALS574A

## AC WAVEFORMS

For all waveforms,  $V_M = 1.3V$ .

The shaded areas indicate when the input is permitted to change for predictable output performance.

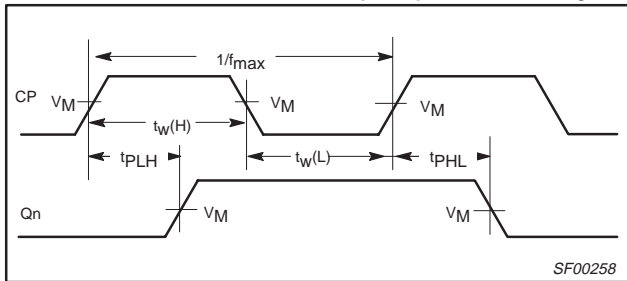

**Waveform 1. Propagation Delay for Clock Input to Output, Clock Pulse Widths, and Maximum Clock Frequency**

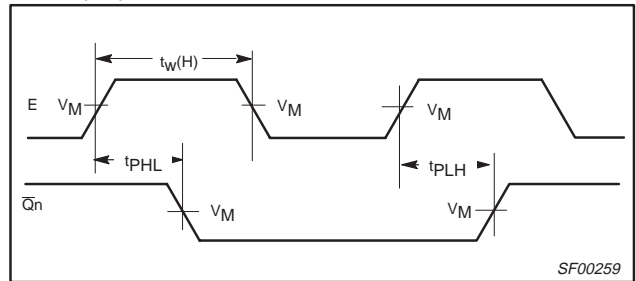

**Waveform 2. Propagation Delay for Enable to Output and Enable Pulse Width**

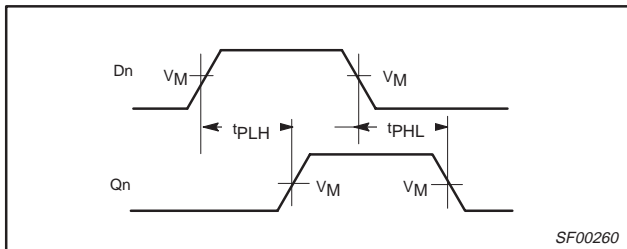

**Waveform 3. Propagation Delay for Data to Output**

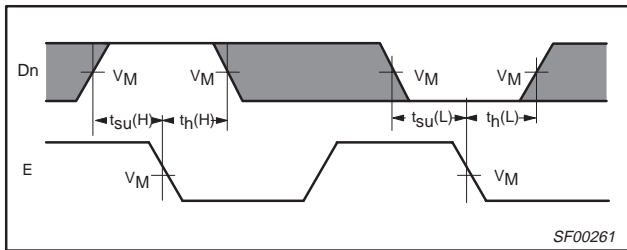

**Waveform 4. Data Setup Time and Hold Times**

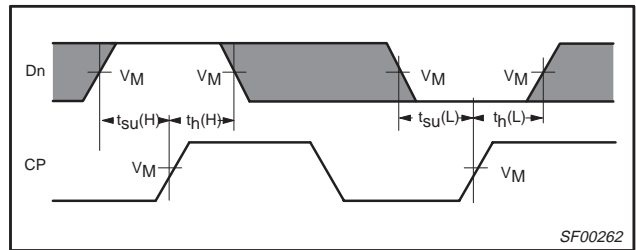

**Waveform 5. Data Setup Time and Hold Times**

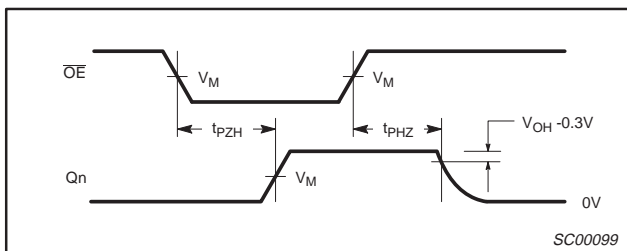

**Waveform 6. 3-State Output Enable Time to High Level and Output Disable Time from High Level**

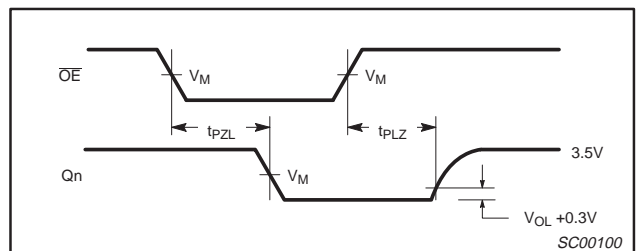

**Waveform 7. 3-State Output Enable Time to Low Level and Output Disable Time from Low Level**



# Latch/flip-flop

# 74ALS573B/74ALS574A

## TEST CIRCUIT AND WAVEFORMS

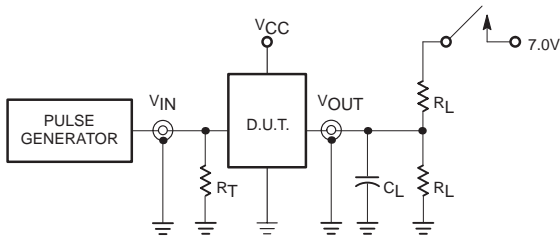

Test Circuit for 3-State Outputs

**SWITCH POSITION**

TEST	SWITCH
$t_{PLZ}$ , $t_{PZL}$	closed
All other	open

**DEFINITIONS:**

- $R_L$  = Load resistor; see AC electrical characteristics for value.
- $C_L$  = Load capacitance includes jig and probe capacitance; see AC electrical characteristics for value.
- $R_T$  = Termination resistance should be equal to  $Z_{OUT}$  of pulse generators.

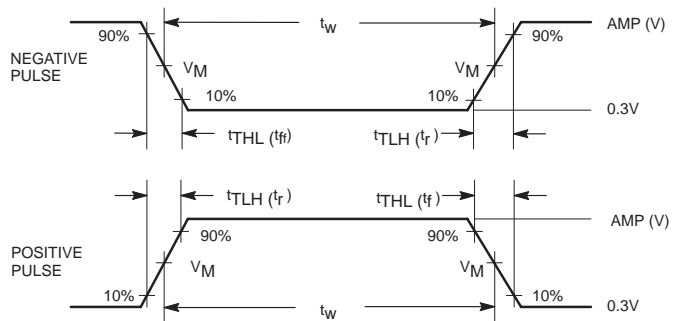

Input Pulse Definition

Family	INPUT PULSE REQUIREMENTS					
	Amplitude	$V_M$	Rep.Rate	$t_w$	$t_{TLH}$	$t_{THL}$
74ALS	3.5V	1.3V	1MHz	500ns	2.0ns	2.0ns

SC00072

Latch/flip-flop

74ALS573B/74ALS574A

DIP20: plastic dual in-line package; 20 leads (300 mil)

SOT146-1

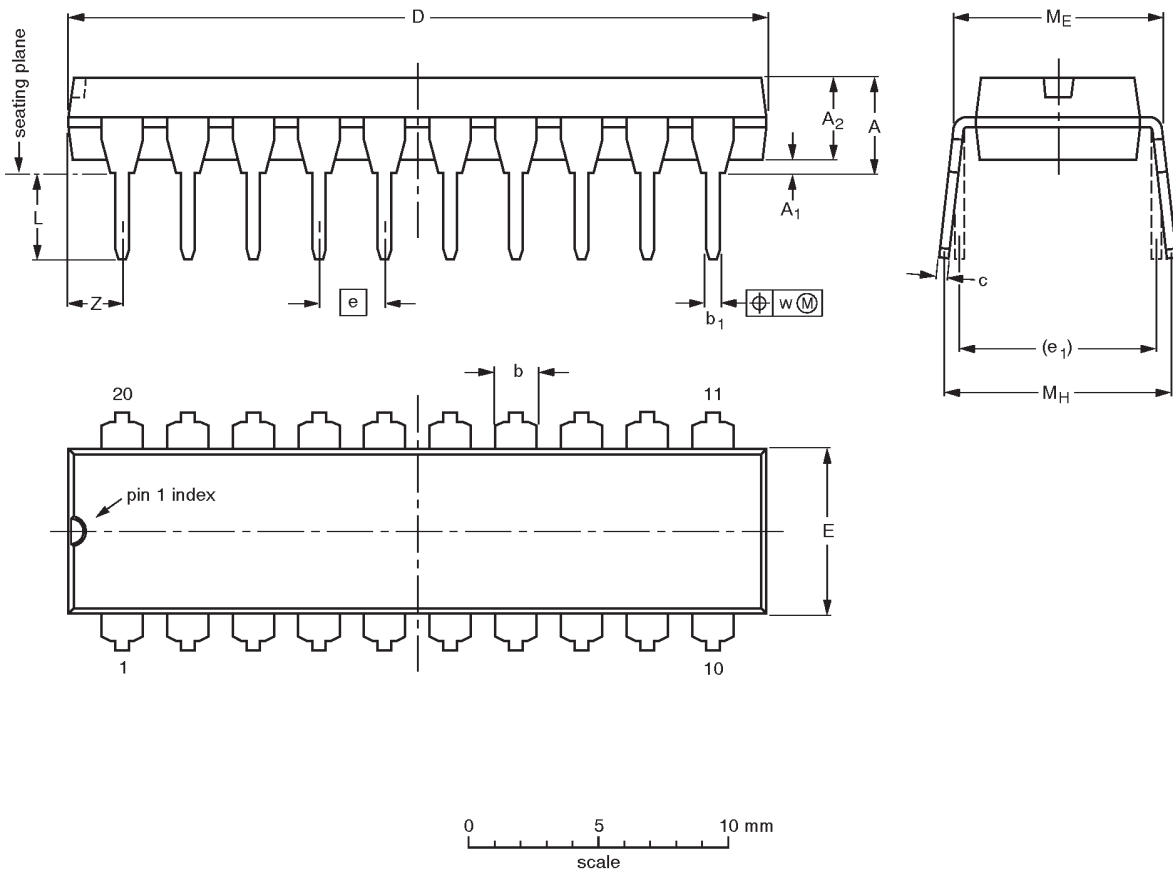

DIMENSIONS (inch dimensions are derived from the original mm dimensions)

UNIT	A max.	A <sub>1</sub> min.	A <sub>2</sub> max.	b	b <sub>1</sub>	c	D <sup>(1)</sup>	E <sup>(1)</sup>	e	e <sub>1</sub>	L	M <sub>E</sub>	M <sub>H</sub>	w	Z <sup>(1)</sup> max.
mm	4.2	0.51	3.2	1.73 1.30	0.53 0.38	0.36 0.23	26.92 26.54	6.40 6.22	2.54	7.62	3.60 3.05	8.25 7.80	10.0 8.3	0.254	2.0
inches	0.17	0.020	0.13	0.068 0.051	0.021 0.015	0.014 0.009	1.060 1.045	0.25 0.24	0.10	0.30	0.14 0.12	0.32 0.31	0.39 0.33	0.01	0.078

Note

1. Plastic or metal protrusions of 0.25 mm maximum per side are not included.

OUTLINE VERSION	REFERENCES				EUROPEAN PROJECTION	ISSUE DATE
	IEC	JEDEC	EIAJ			
SOT146-1			SC603			92-11-17 95-05-24

Latch/flip-flop

74ALS573B/74ALS574A

SO20: plastic small outline package; 20 leads; body width 7.5 mm

SOT163-1

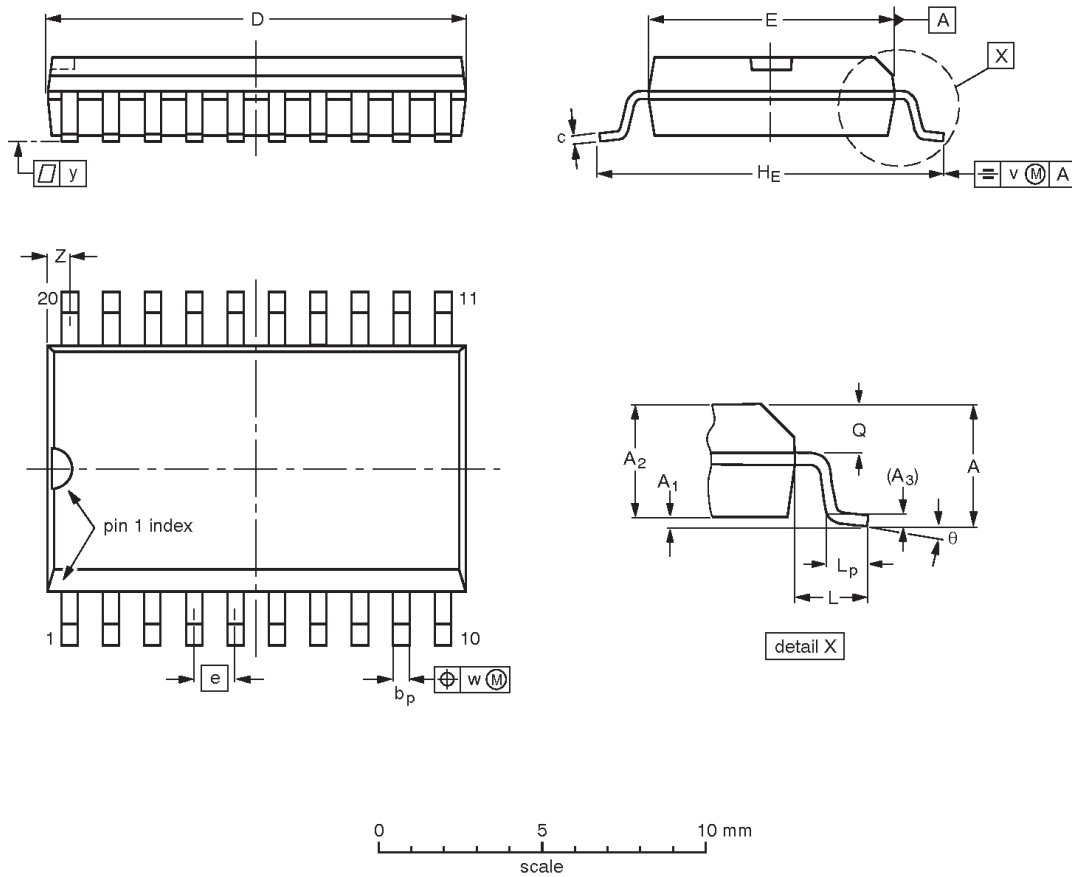

**DIMENSIONS (inch dimensions are derived from the original mm dimensions)**

UNIT	A max.	A <sub>1</sub>	A <sub>2</sub>	A <sub>3</sub>	b <sub>p</sub>	c	D <sup>(1)</sup>	E <sup>(1)</sup>	e	H <sub>E</sub>	L	L <sub>p</sub>	Q	v	w	y	z <sup>(1)</sup>	θ
mm	2.65	0.30 0.10	2.45 2.25	0.25	0.49 0.36	0.32 0.23	13.0 12.6	7.6 7.4	1.27	10.65 10.00	1.4	1.1 0.4	1.1 1.0	0.25	0.25	0.1	0.9 0.4	8° 0°
inches	0.10	0.012 0.004	0.096 0.089	0.01	0.019 0.014	0.013 0.009	0.51 0.49	0.30 0.29	0.050	0.42 0.39	0.055	0.043 0.016	0.043 0.039	0.01	0.01	0.004	0.035 0.016	

**Note**

1. Plastic or metal protrusions of 0.15 mm maximum per side are not included.

OUTLINE VERSION	REFERENCES				EUROPEAN PROJECTION	ISSUE DATE
	IEC	JEDEC	EIAJ			
SOT163-1	075E04	MS-013AC				92-11-17 95-01-24

Latch/flip-flop

74ALS573B/74ALS574A

SSOP20: plastic shrink small outline package; 20 leads; body width 5.3 mm

SOT339-1

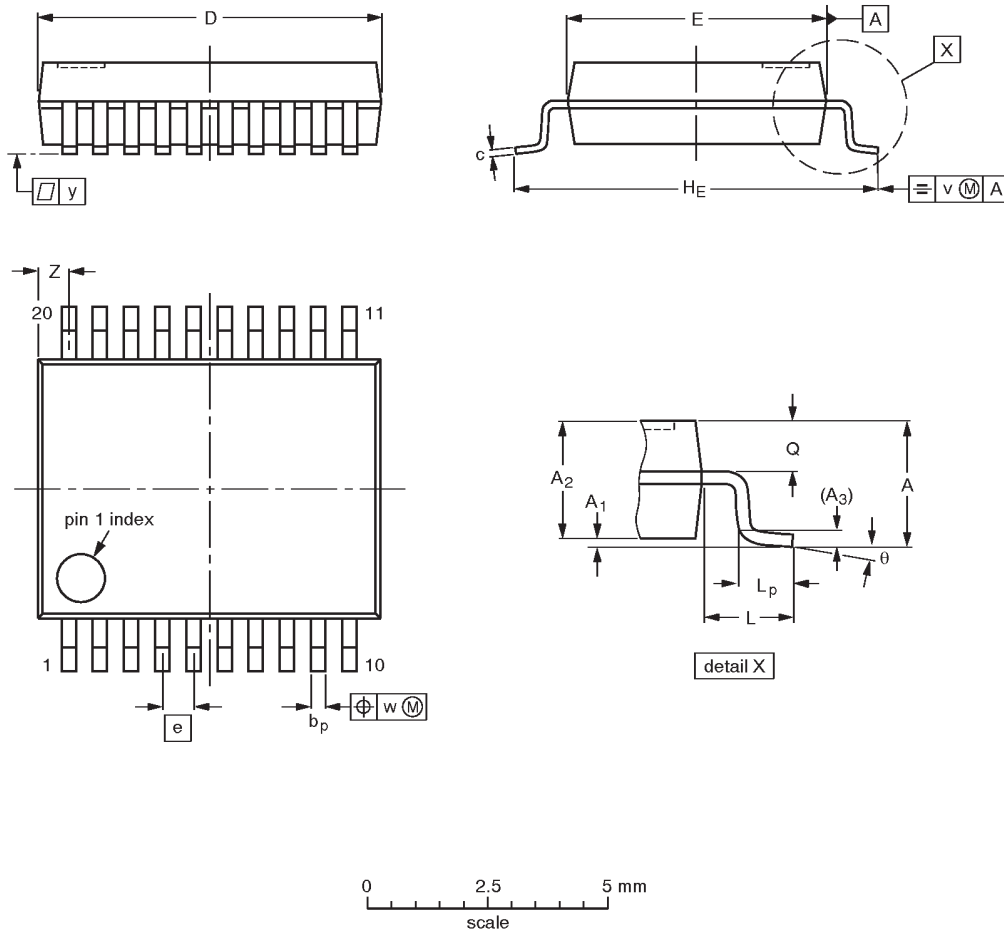

DIMENSIONS (mm are the original dimensions)

UNIT	A max.	A <sub>1</sub>	A <sub>2</sub>	A <sub>3</sub>	b <sub>p</sub>	c	D <sup>(1)</sup>	E <sup>(1)</sup>	e	H <sub>E</sub>	L	L <sub>p</sub>	Q	v	w	y	z <sup>(1)</sup>	θ
mm	2.0	0.21 0.05	1.80 1.65	0.25	0.38 0.25	0.20 0.09	7.4 7.0	5.4 5.2	0.65	7.9 7.6	1.25	1.03 0.63	0.9 0.7	0.2	0.13	0.1	0.9 0.5	8° 0°

Note

1. Plastic or metal protrusions of 0.20 mm maximum per side are not included.

OUTLINE VERSION	REFERENCES				EUROPEAN PROJECTION	ISSUE DATE
	IEC	JEDEC	EIAJ			
SOT339-1		MO-150AE				93-09-08 95-02-04

Latch/flip-flop

74ALS573B/74ALS574A

## DEFINITIONS

Data Sheet Identification	Product Status	Definition
<i>Objective Specification</i>	<b>Formative or in Design</b>	This data sheet contains the design target or goal specifications for product development. Specifications may change in any manner without notice.
<i>Preliminary Specification</i>	<b>Preproduction Product</b>	This data sheet contains preliminary data, and supplementary data will be published at a later date. Philips Semiconductors reserves the right to make changes at any time without notice in order to improve design and supply the best possible product.
<i>Product Specification</i>	<b>Full Production</b>	This data sheet contains Final Specifications. Philips Semiconductors reserves the right to make changes at any time without notice, in order to improve design and supply the best possible product.

Philips Semiconductors and Philips Electronics North America Corporation reserve the right to make changes, without notice, in the products, including circuits, standard cells, and/or software, described or contained herein in order to improve design and/or performance. Philips Semiconductors assumes no responsibility or liability for the use of any of these products, conveys no license or title under any patent, copyright, or mask work right to these products, and makes no representations or warranties that these products are free from patent, copyright, or mask work right infringement, unless otherwise specified. Applications that are described herein for any of these products are for illustrative purposes only. Philips Semiconductors makes no representation or warranty that such applications will be suitable for the specified use without further testing or modification.

## LIFE SUPPORT APPLICATIONS

Philips Semiconductors and Philips Electronics North America Corporation Products are not designed for use in life support appliances, devices, or systems where malfunction of a Philips Semiconductors and Philips Electronics North America Corporation Product can reasonably be expected to result in a personal injury. Philips Semiconductors and Philips Electronics North America Corporation customers using or selling Philips Semiconductors and Philips Electronics North America Corporation Products for use in such applications do so at their own risk and agree to fully indemnify Philips Semiconductors and Philips Electronics North America Corporation for any damages resulting from such improper use or sale.

**Philips Semiconductors**  
**811 East Arques Avenue**  
**P.O. Box 3409**  
**Sunnyvale, California 94088-3409**  
**Telephone 800-234-7381**

© Copyright Philips Electronics North America Corporation 1997  
 All rights reserved. Printed in U.S.A.

*Let's make things better.*

**Philips**  
**Semiconductors**



**PHILIPS**