

# DATA SHEET

For a complete data sheet, please also download:

- The IC06 74HC/HCT/HCU/HCMOS Logic Family Specifications
- The IC06 74HC/HCT/HCU/HCMOS Logic Package Information
- The IC06 74HC/HCT/HCU/HCMOS Logic Package Outlines

## 74HC/HCT648

Octal bus transceiver/register;  
3-state; inverting

Product specification  
File under Integrated Circuits, IC06

December 1990

# Octal bus transceiver/register; 3-state; inverting

## 74HC/HCT648

### FEATURES

- Independent register for A and B buses
- Multiplexed real-time and stored data
- Output capability: bus driver
- I<sub>CC</sub> category: MSI

### GENERAL DESCRIPTION

The 74HC/HCT648 are high-speed Si-gate CMOS devices and are pin compatible with low power Schottky TTL (LSTTL). They are specified in compliance with JEDEC standard no. 7A.

The 74HC/HCT648 consist of bus transceiver circuits with 3-state inverting outputs, D-type flip-flops, and control circuitry arranged for multiplexed transmission of data directly from the internal registers. Data on the "A" or "B"

bus will be clocked into the registers as the appropriate clock (CP<sub>AB</sub> and CP<sub>BA</sub>) goes to a HIGH logic level. Output enable ( $\overline{OE}$ ) and direction (DIR) inputs are provided to control the transceiver function. In the transceiver mode, data present at the high-impedance port may be stored in either the "A" or "B" register, or in both. The select source inputs (S<sub>AB</sub> and S<sub>BA</sub>) can multiplex stored and real-time (transparent mode) data. The direction (DIR) input determines which bus will receive data when  $\overline{OE}$  is active (LOW). In the isolation mode ( $\overline{OE} = \text{HIGH}$ ), "A" data may be stored in the "B" register and/or "B" data may be stored in the "A" register.

When an output function is disabled, the input function is still enabled and may be used to store and transmit data. Only one of the two buses, A or B, may be driven at a time.

The "648" is functionally identical to the "646", but has inverting data paths.

### QUICK REFERENCE DATA

GND = 0 V; T<sub>amb</sub> = 25 °C; t<sub>r</sub> = t<sub>f</sub> = 6 ns

SYMBOL	PARAMETER	CONDITIONS	TYPICAL		UNIT
			HC	HCT	
t <sub>PHL</sub> /t <sub>PLH</sub>	propagation delay $\overline{A}_n, \overline{B}_n$ to $\overline{B}_n, \overline{A}_n$	C <sub>L</sub> = 15 pF; V <sub>CC</sub> = 5 V	11	11	ns
f <sub>max</sub>	maximum clock frequency		75	88	MHz
C <sub>I</sub>	input capacitance		3.5	3.5	pF
C <sub>PD</sub>	power dissipation capacitance per channel	notes 1 and 2	30	31	pF

### Notes

1. C<sub>PD</sub> is used to determine the dynamic power dissipation (P<sub>D</sub> in μW):

$$P_D = C_{PD} \times V_{CC}^2 \times f_i + \sum (C_L \times V_{CC}^2 \times f_o) \text{ where:}$$

f<sub>i</sub> = input frequency in MHz

f<sub>o</sub> = output frequency in MHz

∑ (C<sub>L</sub> × V<sub>CC</sub><sup>2</sup> × f<sub>o</sub>) = sum of outputs

C<sub>L</sub> = output load capacitance in pF

V<sub>CC</sub> = supply voltage in V

2. For HC the condition is V<sub>I</sub> = GND to V<sub>CC</sub>  
For HCT the condition is V<sub>I</sub> = GND to V<sub>CC</sub> - 1.5 V

### ORDERING INFORMATION

See "74HC/HCT/HCU/HCMOS Logic Package Information".

Octal bus transceiver/register; 3-state;  
inverting

74HC/HCT648

PIN DESCRIPTION

PIN NO.	SYMBOL	NAME AND FUNCTION
1	CP <sub>AB</sub>	A to B clock input (LOW-to-HIGH, edge-triggered)
2	S <sub>AB</sub>	select A to B source input
3	DIR	direction control input
4, 5, 6, 7, 8, 9, 10, 11	$\bar{A}_0$ to $\bar{A}_7$	$\bar{A}$ data inputs/outputs
12	GND	ground (0 V)
20, 19, 18, 17, 16, 15, 14, 13	$\bar{B}_0$ to $\bar{B}_7$	$\bar{B}$ data inputs/outputs
21	$\bar{OE}$	output enable input (active LOW)
22	S <sub>BA</sub>	select B to A source input
23	CP <sub>BA</sub>	B to A clock input (LOW-to-HIGH, edge-triggered)
24	V <sub>CC</sub>	positive supply voltage

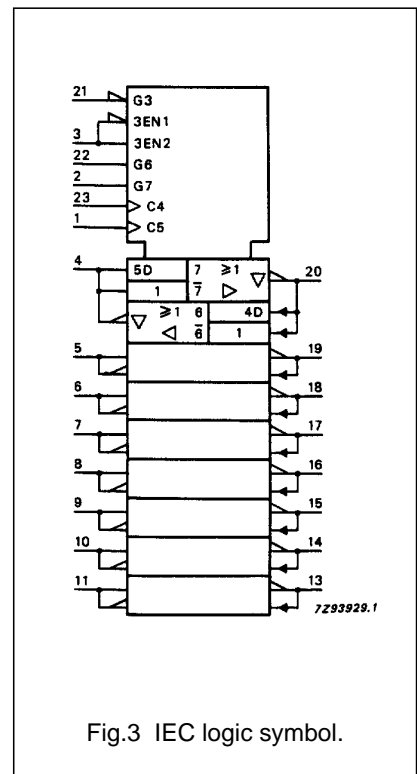
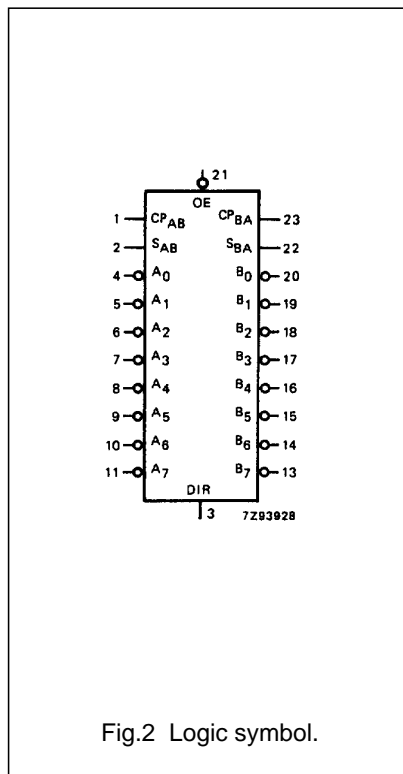
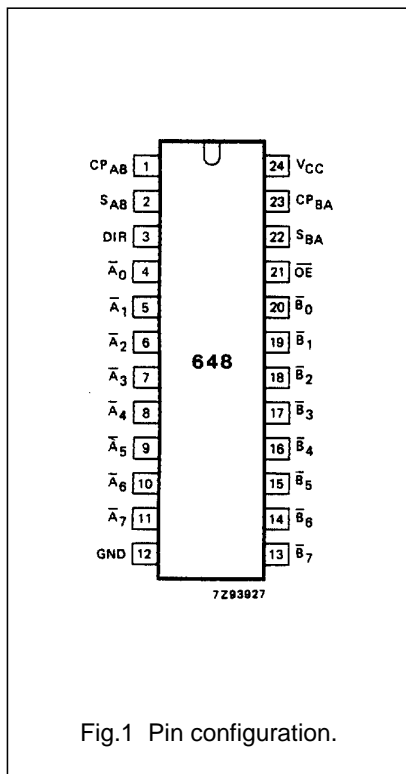

Octal bus transceiver/register; 3-state;  
inverting

74HC/HCT648

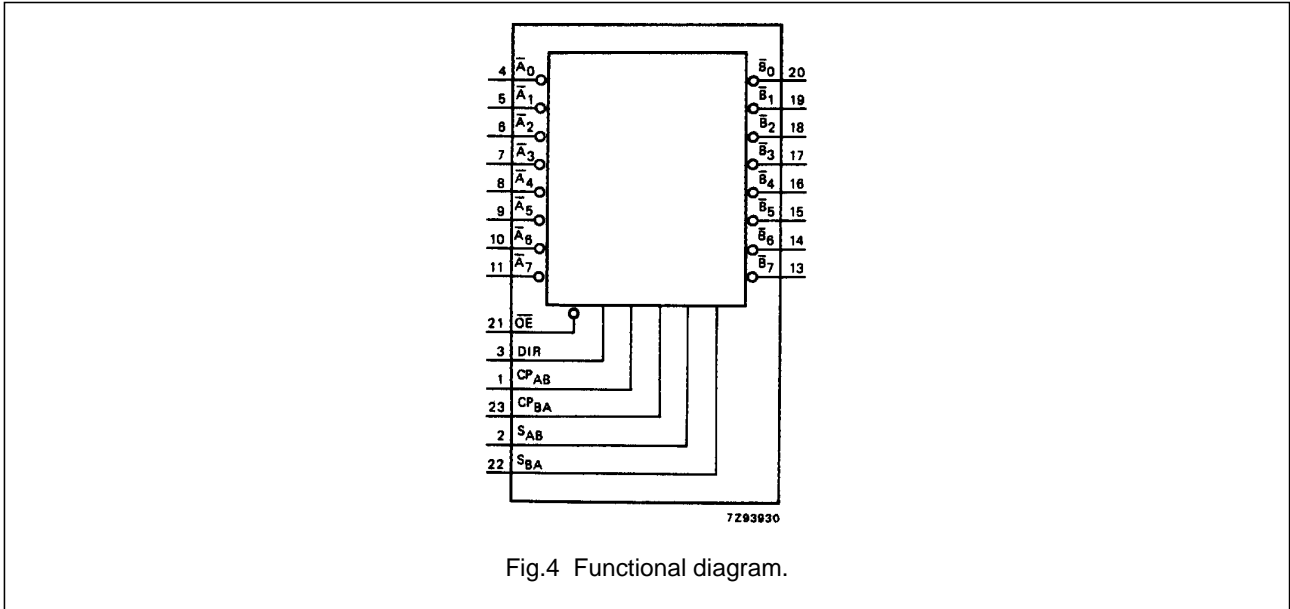

Fig.4 Functional diagram.

FUNCTION TABLE

INPUTS <sup>(1)</sup>						DATA I/O <sup>(2)</sup>		FUNCTION
$\overline{OE}$	DIR	$CP_{AB}$	$CP_{BA}$	$S_{AB}$	$S_{BA}$	$\overline{A}_0$ TO $\overline{A}_7$	$\overline{B}_0$ TO $\overline{B}_7$	
H	X	H or L	H or L	X	X	input	input	isolation store $\overline{A}$ and $\overline{B}$ data
H	X	↑	↑	X	X	input	input	store $\overline{B}$ data to A bus
L	L	X	X	X	L	output	input	real-time $\overline{B}$ data to A bus
L	L	X	H or L	X	H	output	input	stored $\overline{B}$ data to A bus
L	H	X	X	L	X	input	output	real-time $\overline{A}$ data to B bus
L	H	H or L	X	H	X	input	output	stored $\overline{A}$ data to B bus

Notes

- H = HIGH voltage level  
L = LOW voltage level  
X = don't care  
↑ = LOW-to-HIGH level transition
- The data output functions may be enabled or disabled by various signals at the  $\overline{OE}$  and DIR inputs. Data input functions are always enabled, i.e., data at the bus inputs will be stored on every LOW-to-HIGH transition on the clock inputs.

Octal bus transceiver/register; 3-state;  
inverting

74HC/HCT648

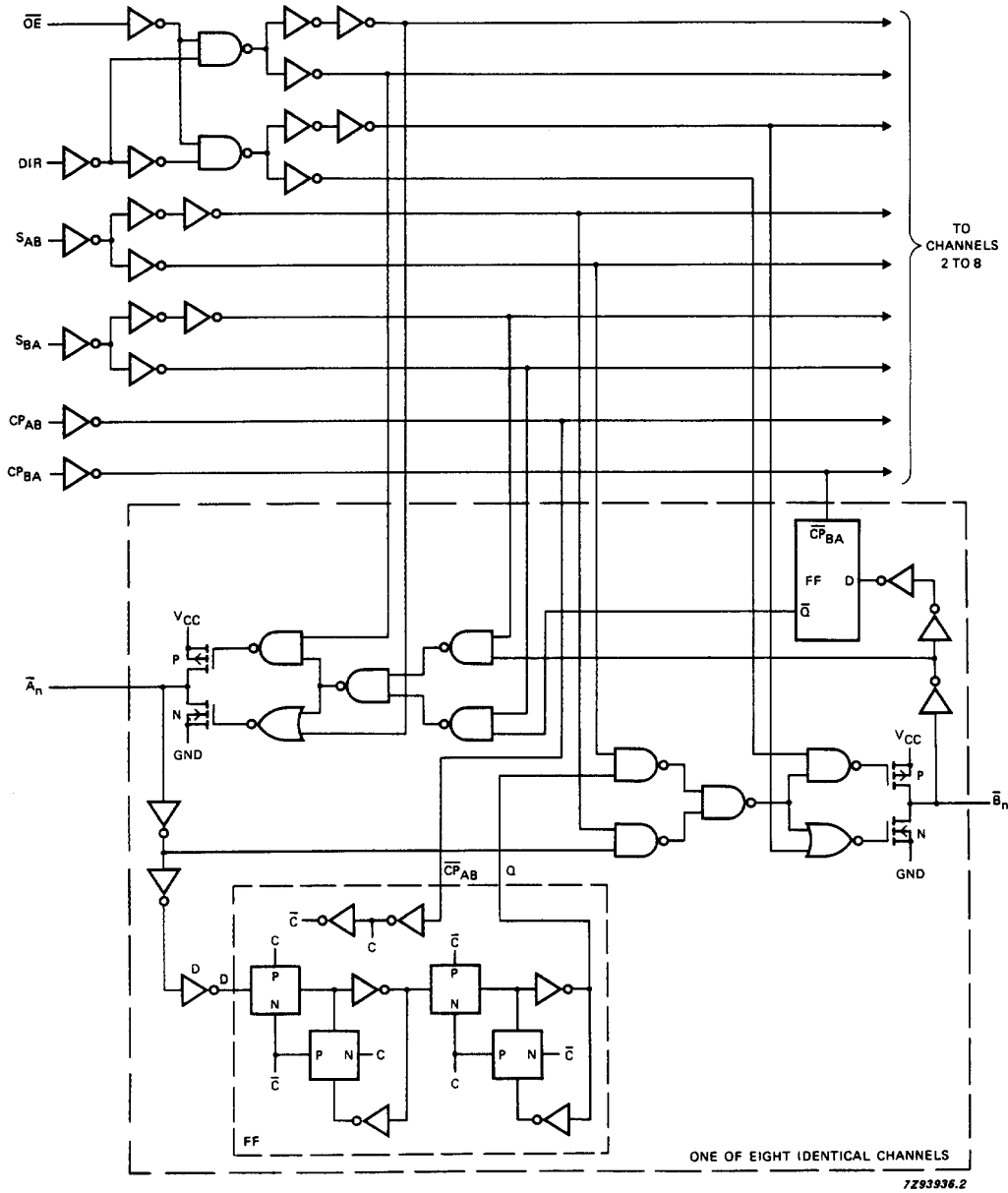

Fig.5 Logic diagram.

# Octal bus transceiver/register; 3-state; inverting

74HC/HCT648

## DC CHARACTERISTICS FOR 74HC

For the DC characteristics see "74HC/HCT/HCU/HCMOS Logic Family Specifications".

Output capability: bus driver

I<sub>CC</sub> category: MSI

## AC CHARACTERISTICS FOR 74HC

GND = 0 V; t<sub>r</sub> = t<sub>f</sub> = 6 ns; C<sub>L</sub> = 50 pF

SYMBOL	PARAMETER	T <sub>amb</sub> (°C)							UNIT	TEST CONDITIONS	
		74HC								V <sub>CC</sub> (V)	WAVEFORMS
		+25			-40 to +85		-40 to +125				
		min.	typ.	max.	min.	max.	min.	max.			
t <sub>PHL</sub> / t <sub>PLH</sub>	propagation delay A <sub>n</sub> , B <sub>n</sub> to B <sub>n</sub> , A <sub>n</sub>		39 14 11	135 27 23		170 34 29		205 41 35	ns	2.0 4.5 6.0	Fig.6
t <sub>PHL</sub> / t <sub>PLH</sub>	propagation delay CP <sub>AB</sub> , CP <sub>BA</sub> to B <sub>n</sub> , A <sub>n</sub>		74 27 22	230 46 39		290 58 49		345 69 59	ns	2.0 4.5 6.0	Fig.7
t <sub>PHL</sub> / t <sub>PLH</sub>	propagation delay S <sub>AB</sub> , S <sub>BA</sub> to B <sub>n</sub> , A <sub>n</sub>		55 20 16	190 38 32		240 48 41		285 57 48	ns	2.0 4.5 6.0	Fig.8
t <sub>PZH</sub> / t <sub>PZL</sub>	3-state output enable time OE to A <sub>n</sub> , B <sub>n</sub>		52 19 15	175 35 30		220 44 37		265 53 45	ns	2.0 4.5 6.0	Fig.9
t <sub>PHZ</sub> / t <sub>PLZ</sub>	3-state output disable time OE to A <sub>n</sub> , B <sub>n</sub>		61 22 18	175 35 30		220 44 37		265 53 45	ns	2.0 4.5 6.0	Fig.9
t <sub>PZH</sub> / t <sub>PZL</sub>	3-state output enable time DIR to A <sub>n</sub> , B <sub>n</sub>		52 19 15	175 35 30		220 44 37		265 53 45	ns	2.0 4.5 6.0	Fig.10
t <sub>PHZ</sub> / t <sub>PLZ</sub>	3-state output disable time DIR to A <sub>n</sub> , B <sub>n</sub>		55 20 16	175 35 30		220 44 37		265 53 45	ns	2.0 4.5 6.0	Fig.10
t <sub>THL</sub> / t <sub>TLH</sub>	output transition time		14 5 4	60 12 10		75 15 13		90 18 15	ns	2.0 4.5 6.0	Fig.6 and Fig.8
t <sub>w</sub>	clock pulse width HIGH or LOW CP <sub>AB</sub> or CP <sub>BA</sub>	80 16 14	25 9 7		100 20 17		120 24 20		ns	2.0 4.5 6.0	Fig.7
t <sub>su</sub>	set-up time A <sub>n</sub> , B <sub>n</sub> to CP <sub>AB</sub> , CP <sub>BA</sub>	60 12 10	0 0 0		75 15 13		90 18 15		ns	2.0 4.5 6.0	Fig.7
t <sub>h</sub>	hold time A <sub>n</sub> , B <sub>n</sub> to CP <sub>AB</sub> , CP <sub>BA</sub>	35 7 6	6 2 2		45 9 8		55 11 9		ns	2.0 4.5 6.0	Fig.7
f <sub>max</sub>	maximum clock pulse frequency	6.0 30 35	22 68 81		4.8 24 28		4.0 20 24		MHz	2.0 4.5 6.0	Fig.7

---

**Octal bus transceiver/register; 3-state;  
inverting**

---

**74HC/HCT648****DC CHARACTERISTICS FOR 74HCT**

For the DC characteristics see *"74HC/HCT/HCU/HCMOS Logic Family Specifications"*.

Output capability: bus driver

I<sub>CC</sub> category: MSI

**Note to HCT types**

The value of additional quiescent supply current ( $\Delta I_{CC}$ ) for a unit load of 1 is given in the family specifications. To determine  $\Delta I_{CC}$  per input, multiply this value by the unit load coefficient shown in the table below.

INPUT	UNIT LOAD COEFFICIENT
S <sub>AB</sub> , S <sub>BA</sub>	0.60
A <sub>0</sub> to A <sub>7</sub> ; and $\bar{B}_0$ to $\bar{B}_7$ ;	0.75

INPUT	UNIT LOAD COEFFICIENT
CP <sub>AB</sub> ; CP <sub>BA</sub> ;	1.50
OE	1.50
DIR	1.25

# Octal bus transceiver/register; 3-state; inverting

74HC/HCT648

**AC CHARACTERISTICS FOR 74HCT**GND = 0 V;  $t_r = t_f = 6$  ns;  $C_L = 50$  pF

SYMBOL	PARAMETER	$T_{amb}$ (°C)							UNIT	TEST CONDITIONS	
		74HCT								$V_{CC}$ (V)	WAVEFORMS
		+25			-40 to +85		-40 to +125				
		min.	typ.	max.	min.	max.	min.	max.			
$t_{PHL}/t_{PLH}$	propagation delay $\bar{A}_n, \bar{B}_n$ to $\bar{B}_n, \bar{A}_n$		14	27		34		41	ns	4.5	Fig.6
$t_{PHL}/t_{PLH}$	propagation delay $CP_{AB}, CP_{BA}$ to $\bar{B}_n, \bar{A}_n$		25	46		58		69	ns	4.5	Fig.7
$t_{PHL}/t_{PLH}$	propagation delay $S_{AB}, S_{BA}$ to $\bar{B}_n, \bar{A}_n$		20	38		48		57	ns	4.5	Fig.8
$t_{PZH}/t_{PZL}$	3-state output enable time $\bar{OE}$ to $\bar{A}_n, \bar{B}_n$		21	40		50		60	ns	4.5	Fig.9
$t_{PHZ}/t_{PLZ}$	3-state output disable time $\bar{OE}$ to $\bar{A}_n, \bar{B}_n$		20	35		44		53	ns	4.5	Fig.9
$t_{PZH}/t_{PZL}$	3-state output enable time DIR to $\bar{A}_n, \bar{B}_n$		20	40		50		60	ns	4.5	Fig.10
$t_{PHZ}/t_{PLZ}$	3-state output disable time DIR to $\bar{A}_n, \bar{B}_n$		21	35		44		53	ns	4.5	Fig.10
$t_{THL}/t_{TLH}$	output transition time		5	12		15		18	ns	4.5	Fig.6 and Fig.8
$t_W$	clock pulse width HIGH or LOW $CP_{AB}$ or $CP_{BA}$	16	7		20		24		ns	4.5	Fig.7
$t_{su}$	set-up time $\bar{A}_n, \bar{B}_n$ to $CP_{AB}, CP_{BA}$	12	2		15		18		ns	4.5	Fig.7
$t_h$	hold time $A_n, B_n$ to $CP_{AB}, CP_{BA}$	5	0		5		5		ns	4.5	Fig.7
$f_{max}$	maximum clock pulse frequency	30	80		24		20		ns	MHz	Fig.7



Octal bus transceiver/register; 3-state;  
inverting

74HC/HCT648

AC WAVEFORMS

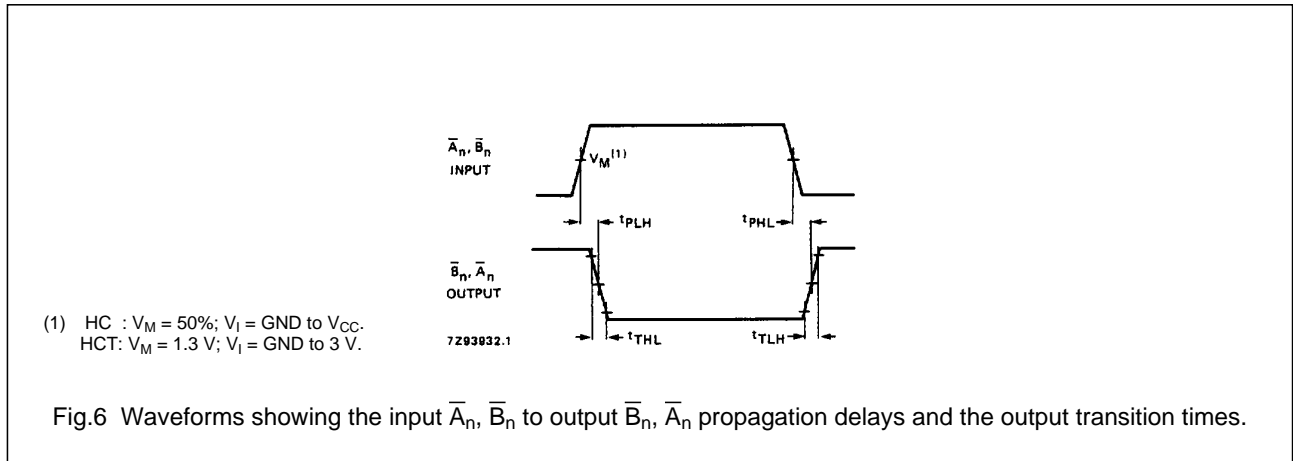

Fig.6 Waveforms showing the input  $\bar{A}_n, \bar{B}_n$  to output  $\bar{B}_n, \bar{A}_n$  propagation delays and the output transition times.

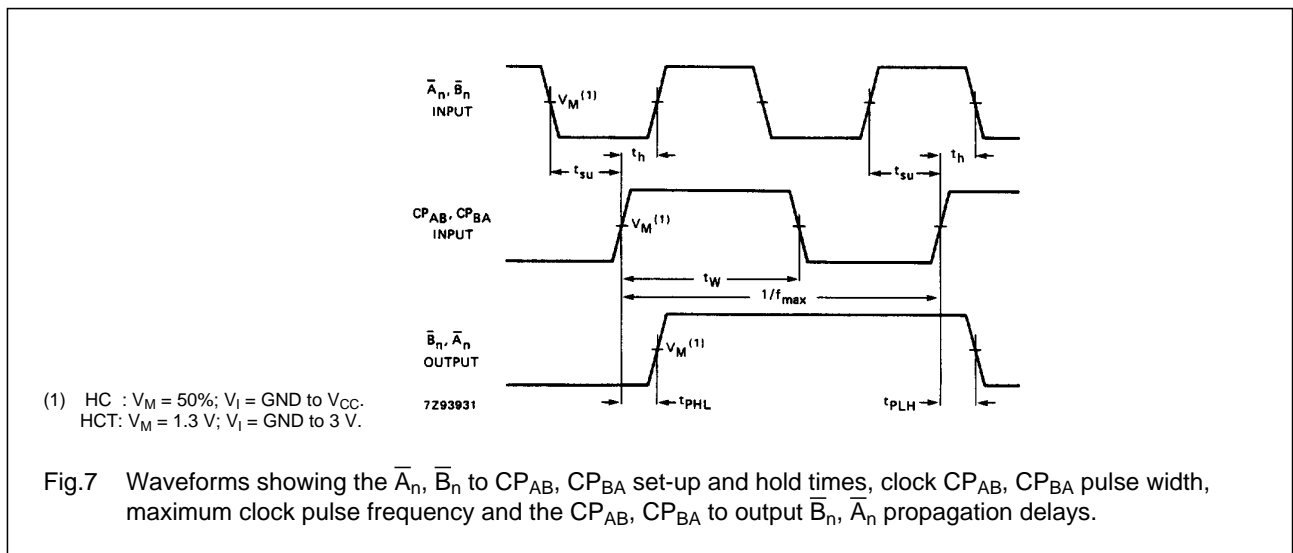

Fig.7 Waveforms showing the  $\bar{A}_n, \bar{B}_n$  to  $CP_{AB}, CP_{BA}$  set-up and hold times, clock  $CP_{AB}, CP_{BA}$  pulse width, maximum clock pulse frequency and the  $CP_{AB}, CP_{BA}$  to output  $\bar{B}_n, \bar{A}_n$  propagation delays.

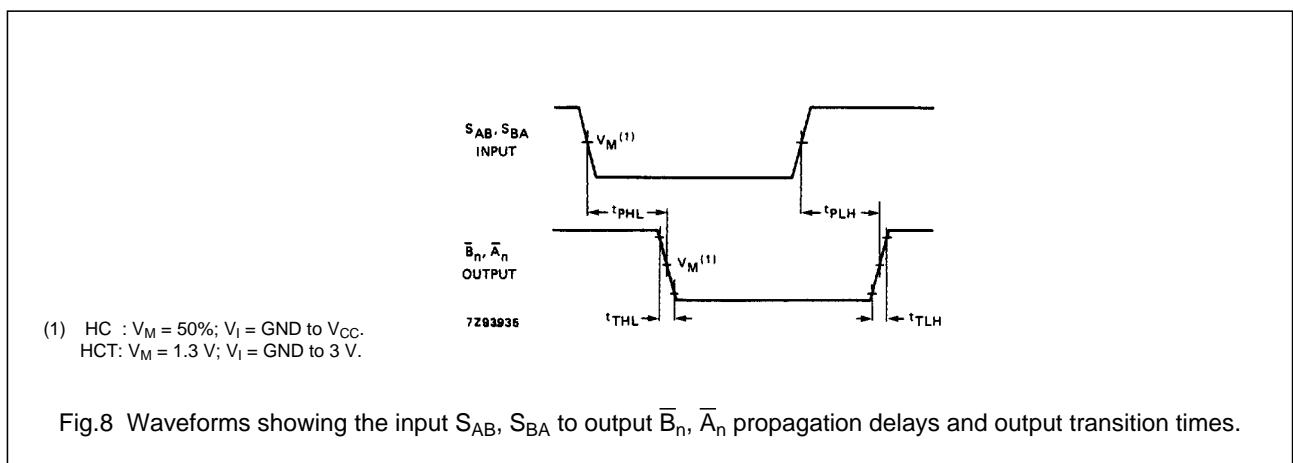
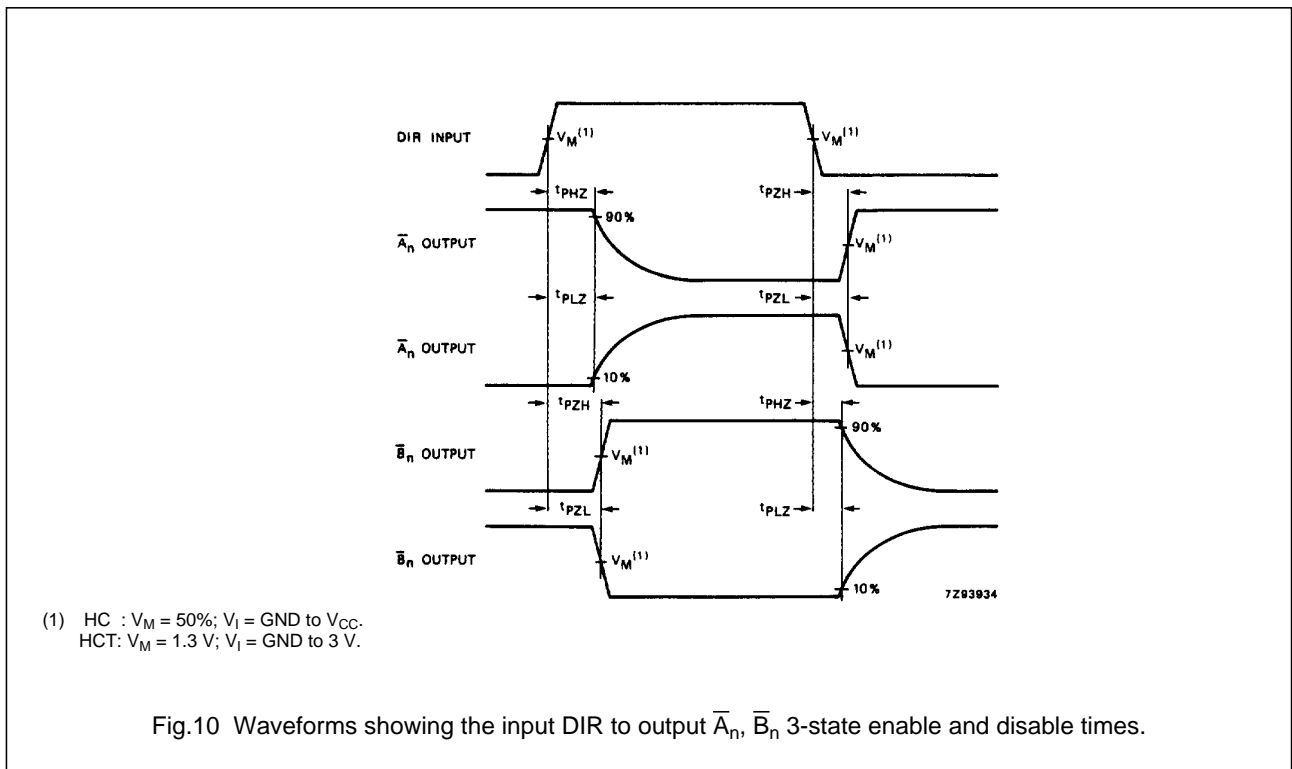
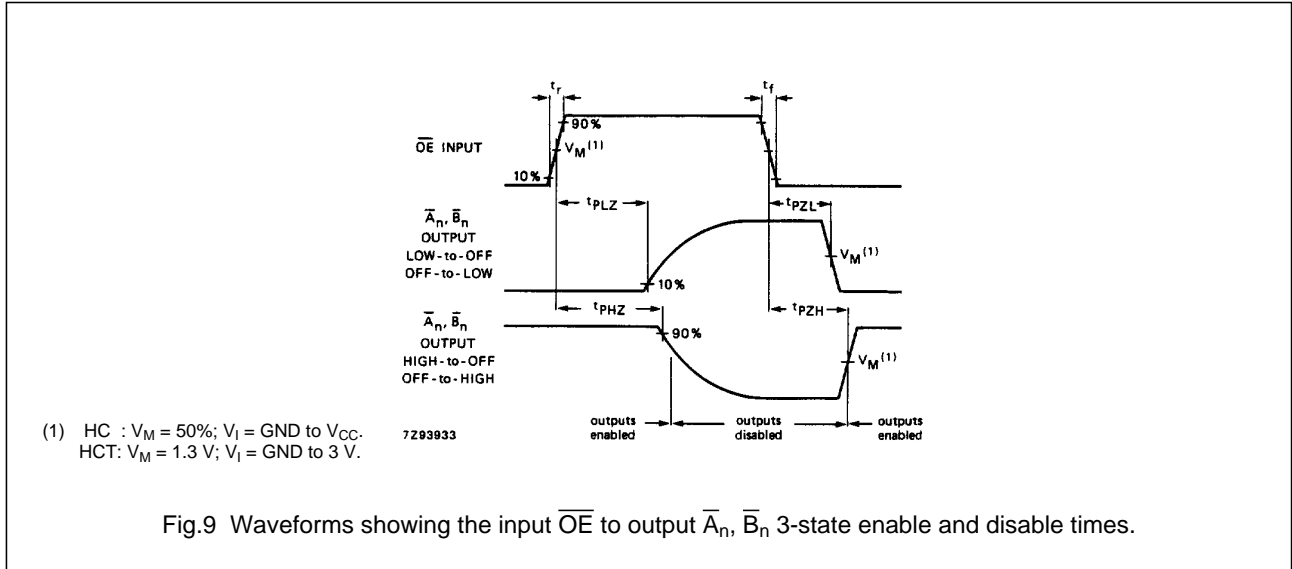

Fig.8 Waveforms showing the input  $S_{AB}, S_{BA}$  to output  $\bar{B}_n, \bar{A}_n$  propagation delays and output transition times.

Octal bus transceiver/register; 3-state;  
inverting

74HC/HCT648



Octal bus transceiver/register; 3-state;  
inverting

74HC/HCT648

APPLICATION INFORMATION

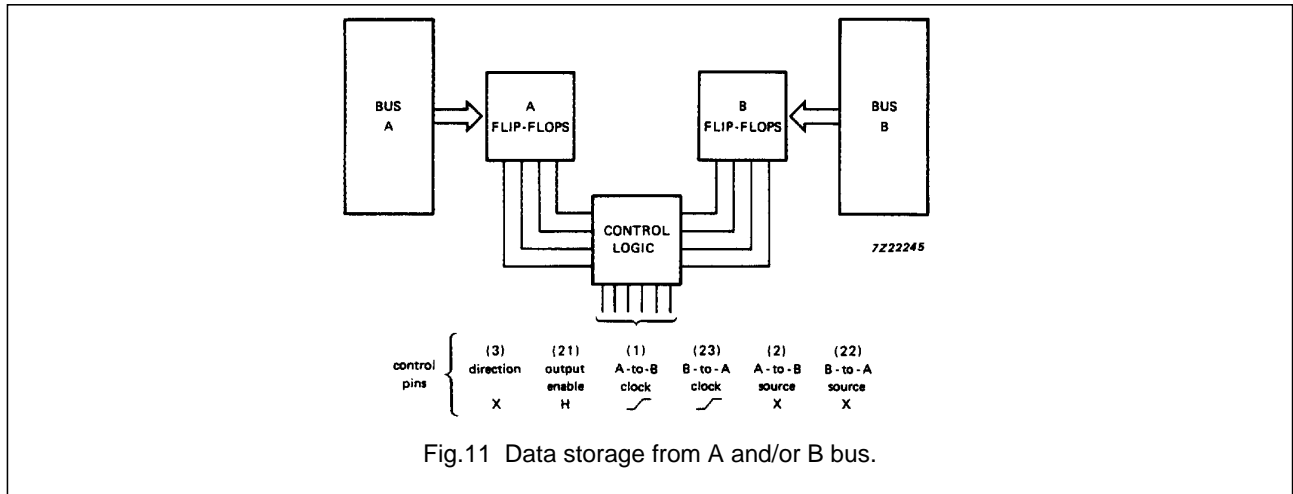

Fig.11 Data storage from A and/or B bus.

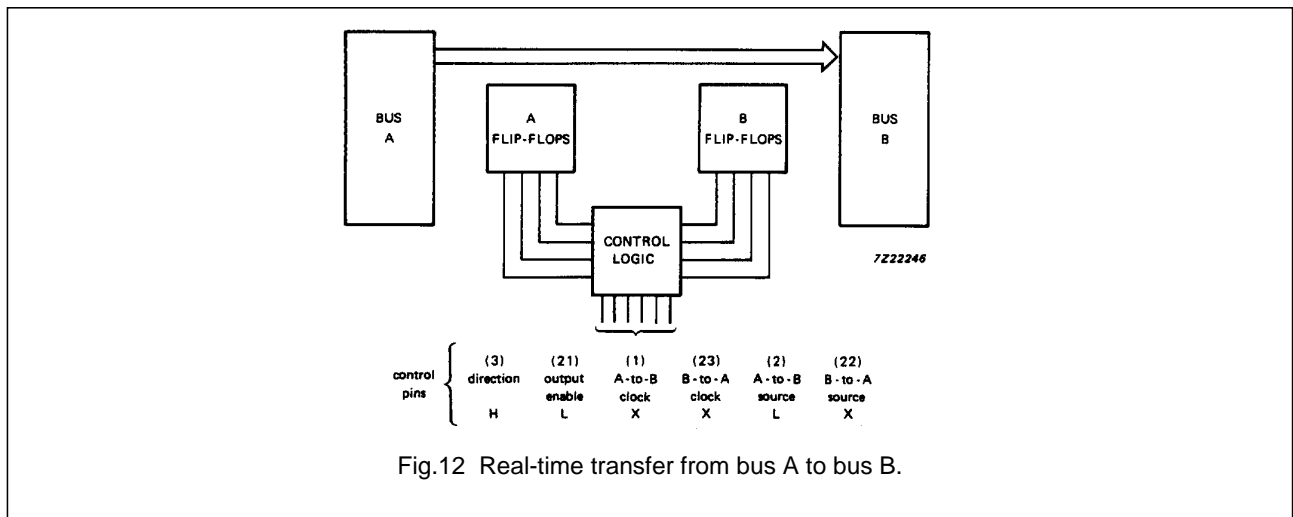

Fig.12 Real-time transfer from bus A to bus B.

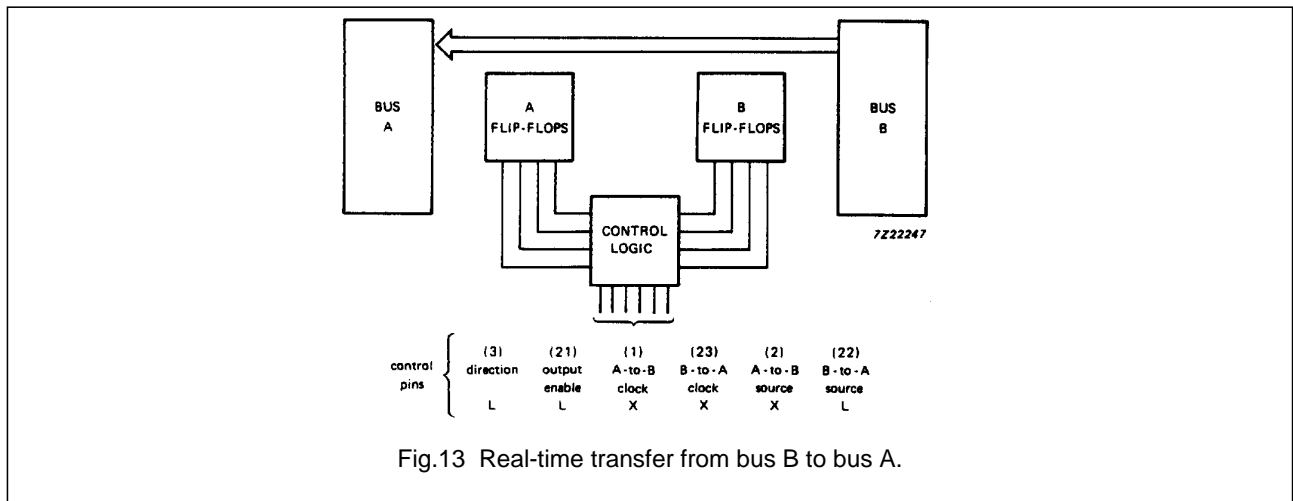

Fig.13 Real-time transfer from bus B to bus A.

---

Octal bus transceiver/register; 3-state;  
inverting

---

74HC/HCT648

**PACKAGE OUTLINES**

See *"74HC/HCT/HCU/HCMOS Logic Package Outlines"*.