

DATA SHEET

For a complete data sheet, please also download:

- The IC06 74HC/HCT/HCU/HCMOS Logic Family Specifications
- The IC06 74HC/HCT/HCU/HCMOS Logic Package Information
- The IC06 74HC/HCT/HCU/HCMOS Logic Package Outlines

74HC/HCT7540

Octal Schmitt trigger buffer/line driver; 3-state; inverting

Product specification
Supersedes data of March 1988
File under Integrated Circuits, IC06

December 1990

Octal Schmitt trigger buffer/line driver; 3-state; inverting

74HC/HCT7540

FEATURES

- Inverting outputs
- Schmitt trigger action on all data inputs
- Output capability: bus driver
- I_{CC} category: MSI

GENERAL DESCRIPTION

The 74HC/HCT7540 are high-speed Si-gate CMOS devices and are pin compatible with low power Schottky TTL (LSTTL). They are specified in compliance with JEDEC standard no. 7A.

The 74HC/HCT7540 are octal Schmitt trigger inverting buffer/line drivers with 3-state outputs. The 3-state outputs are controlled by the output enable inputs \overline{OE}_1 and \overline{OE}_2 .

A HIGH on \overline{OE}_n causes the outputs to assume a high impedance OFF-state.

The Schmitt trigger action in the data inputs transforms slowly changing input signals into sharply defined jitter-free output signals.

The "7540" is identical to the "540" but has hysteresis on the data inputs.

QUICK REFERENCE DATA

GND = 0 V; T_{amb} = 25 °C; t_r = t_f = 6 ns

SYMBOL	PARAMETER	CONDITIONS	TYPICAL		UNIT
			HC	HCT	
t _{PHL} / t _{PLH}	propagation delay A _n to \overline{Y}_n	C _L = 15 pF; V _{CC} = 5 V	11	16	ns
C _I	input capacitance		3.5	3.5	pF
C _{PD}	power dissipation capacitance per buffer	notes 1 and 2	29	31	pF

Notes

1. C_{PD} is used to determine the dynamic power dissipation (P_D in μW):

$$P_D = C_{PD} \times V_{CC}^2 \times f_i + \sum (C_L \times V_{CC}^2 \times f_o) \text{ where:}$$

f_i = input frequency in MHz

f_o = output frequency in MHz

∑ (C_L × V_{CC}² × f_o) = sum of outputs

C_L = output load capacitance in pF

V_{CC} = supply voltage in V

2. For HC the condition is V_I = GND to V_{CC}

For HCT the condition is V_I = GND to V_{CC} – 1.5 V

ORDERING INFORMATION

See "74HC/HCT/HCU/HCMOS Logic Package Information".

Octal Schmitt trigger buffer/line driver;
3-state; inverting

74HC/HCT7540

PIN DESCRIPTION

PIN NO.	SYMBOL	NAME AND FUNCTION
1, 19	$\overline{OE}_1, \overline{OE}_2$	output enable inputs (active LOW)
2, 3, 4, 5, 6, 7, 8, 9	A_0 to A_7	data inputs
10	GND	ground (0 V)
18, 17, 16, 15, 14, 13, 12, 11	\overline{Y}_0 to \overline{Y}_7	bus outputs
20	V_{CC}	positive supply voltage

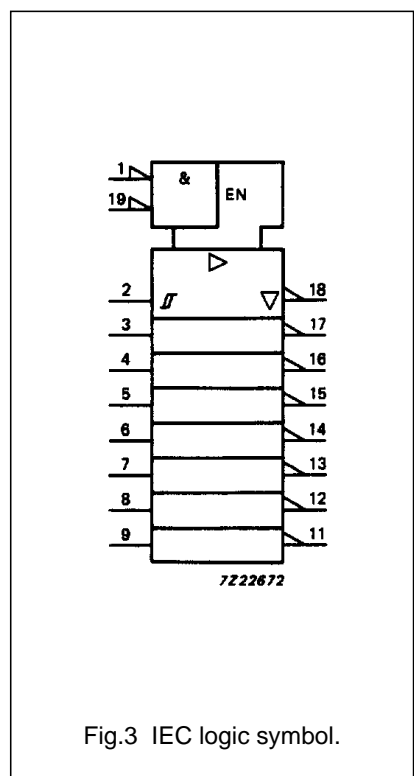
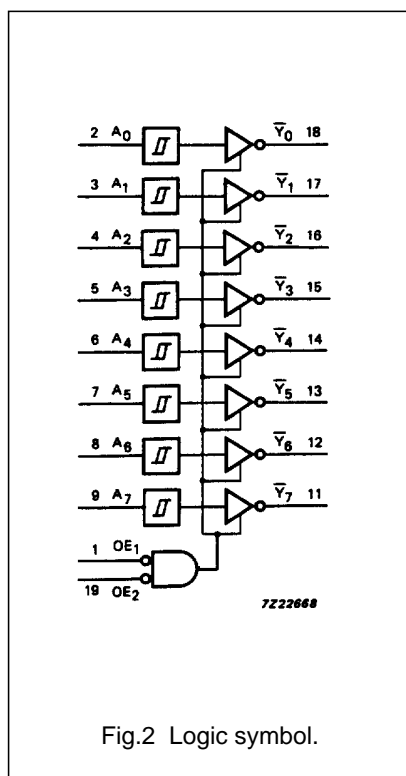
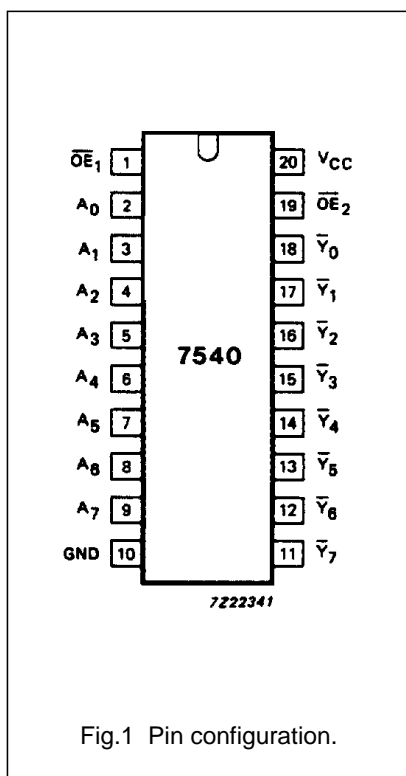

Octal Schmitt trigger buffer/line driver;
3-state; inverting

74HC/HCT7540

FUNCTION TABLE

INPUTS			OUTPUTS
\overline{OE}_1	\overline{OE}_2	A_n	\overline{Y}_n
L	L	L	H
L	L	H	L
X	H	X	Z
H	X	X	Z

Notes

- H = HIGH voltage level
L = LOW voltage level
X = don't care
Z = high impedance OFF-state

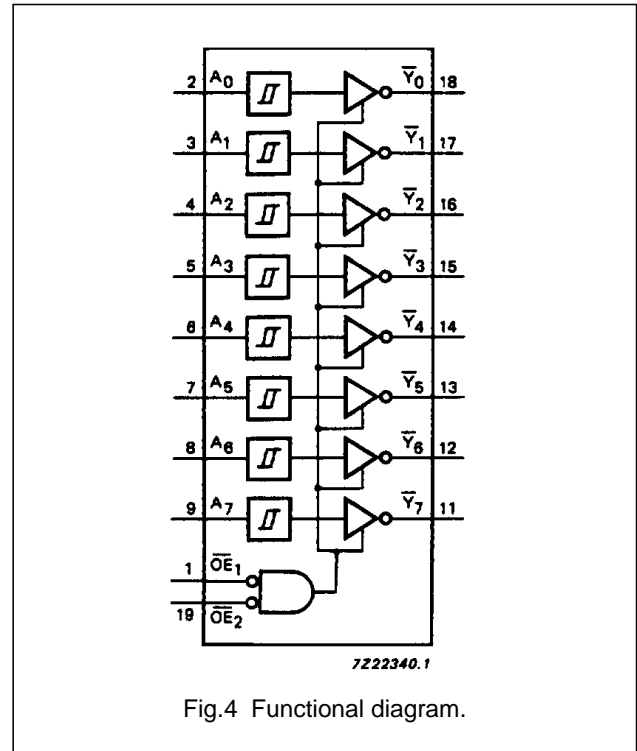

Fig.4 Functional diagram.

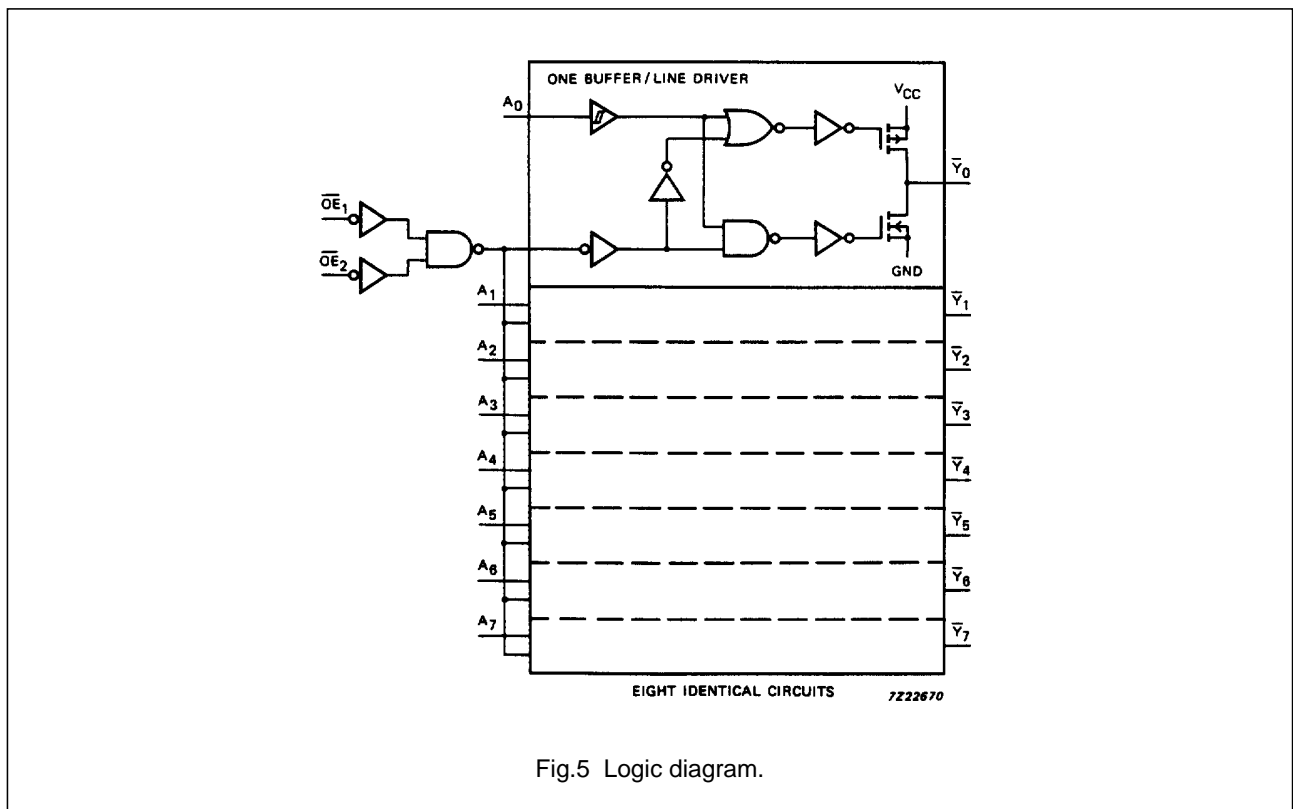

Fig.5 Logic diagram.

Octal Schmitt trigger buffer/line driver; 3-state; inverting

74HC/HCT7540

DC CHARACTERISTICS FOR 74HC

For the DC characteristics see *"74HC/HCT/HCU/HCMOS Logic Family Specifications"*.
Transfer characteristics are given below (not applicable for \overline{OE}_n inputs).

Output capability: bus driver
I_{CC} category: MSI

AC CHARACTERISTICS FOR 74HC

GND = 0 V; t_r = t_f = 6 ns; C_L = 50 pF

SYMBOL	PARAMETER	T _{amb} (°C)							UNIT	TEST CONDITIONS	
		74HC								V _{CC} (V)	WAVEFORMS
		+25			-40 to +85		-40 to +125				
		min.	typ.	max.	min.	max.	min.	max.			
t _{PHL} / t _{PLH}	propagation delay A _n to \overline{Y}_n		39 14 11	120 24 20		150 30 26		180 36 31	ns	2.0 4.5 6.0	Fig.8
t _{PZH} / t _{PZL}	3-state output enable time \overline{OE}_n to \overline{Y}_n		41 15 12	150 30 26		190 38 33		225 45 38	ns	2.0 4.5 6.0	Fig.9
t _{PHZ} / t _{PLZ}	3-state output disable time \overline{OE}_n to \overline{Y}_n		52 19 15	150 30 26		190 38 33		225 45 38	ns	2.0 4.5 6.0	Fig.9
t _{THL} / t _{TLH}	output transition time		14 5 4	60 12 10		75 15 13		90 18 15	ns	2.0 4.5 6.0	Fig.8

TRANSFER CHARACTERISTICS FOR 74HC

Voltages are referred to GND (ground = 0 V)

SYMBOL	PARAMETER	T _{amb} (°C)							UNIT	TEST CONDITIONS	
		74HC								V _{CC} (V)	WAVEFORMS
		+25			-40 to +85		-40 to +125				
		min.	typ.	max.	min.	max.	min.	max.			
V _{T+}	positive-going threshold			1.50 3.15 4.20		1.50 3.15 4.20		1.50 3.15 4.20	V	2.0 4.5 6.0	Figs 6 and 7
V _{T-}	negative-going threshold	0.30 1.35 1.80			0.30 1.35 1.80		0.30 1.35 1.80		V	2.0 4.5 6.0	Figs 6 and 7
V _H	hysteresis (V _{T+} - V _{T-})	0.10 0.25 0.30	0.20 0.40 0.50		0.10 0.25 0.30		0.10 0.25 0.30		V	2.0 4.5 6.0	Figs 6 and 7

Octal Schmitt trigger buffer/line driver; 3-state; inverting

74HC/HCT7540

DC CHARACTERISTICS FOR 74HCT

For the DC characteristics see *"74HC/HCT/HCU/HCMOS Logic Family Specifications"*.
Transfer characteristics are given below (not applicable for \overline{OE}_n inputs).

Output capability: bus driver
 I_{CC} category: MSI

Note to HCT types

The value of additional quiescent supply current (ΔI_{CC}) for a unit load of 1 is given in the family specifications.
To determine ΔI_{CC} per input, multiply this value by the unit load coefficient shown in the table below.

INPUT	UNIT LOAD
\overline{OE}_1	1.30
\overline{OE}_2	1.30
A_n	0.20

AC CHARACTERISTICS FOR 74HCT

GND = 0 V; $t_r = t_f = 6$ ns; $C_L = 50$ pF

SYMBOL	PARAMETER	T_{amb} (°C)						UNIT	TEST CONDITIONS		
		74HCT							V_{CC} (V)	WAVEFORMS	
		+25			-40 to +85		-40 to +125				
		min	typ.	max.	min	max.	min.				max.
t_{PHL}/t_{PLH}	propagation delay A_n to \overline{Y}_n		19	32		40		48	ns	4.5	Fig.8
t_{PZH}/t_{PZL}	3-state output enable time \overline{OE}_n to \overline{Y}_n		19	32		40		48	ns	4.5	Fig.9
t_{PHZ}/t_{PLZ}	3-state output disable time \overline{OE}_n to \overline{Y}_n		20	32		40		48	ns	4.5	Fig.9
t_{THL}/t_{TLH}	output transition time		5	12		15		18	ns	4.5	Fig.8

TRANSFER CHARACTERISTICS FOR 74HCT

Voltages are referred to GND (ground = 0 V)

SYMBOL	PARAMETER	T_{amb} (°C)						UNIT	TEST CONDITIONS		
		74HCT							V_{CC} (V)	WAVEFORMS	
		+25			-40 to +85		-40 to +125				
		min	typ.	max.	min	max.	min.				max.
V_{T+}	positive-going threshold			2.0 2.1		2.0 2.1		2.0 2.1	V	4.5 5.5	Figs 6 and 7
V_{T-}	negative-going threshold	0.70 0.80			0.64 0.74		0.60 0.70		V	4.5 5.5	Figs 6 and 7
V_H	hysteresis ($V_{T+} - V_{T-}$)	0.17 0.17	0.23 0.23						V	4.5 5.5	Figs 6 and 7

Octal Schmitt trigger buffer/line driver;
3-state; inverting

74HC/HCT7540

TRANSFER CHARACTERISTIC WAVEFORMS

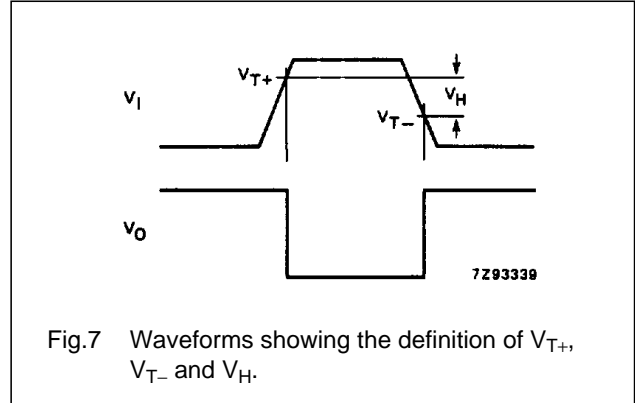
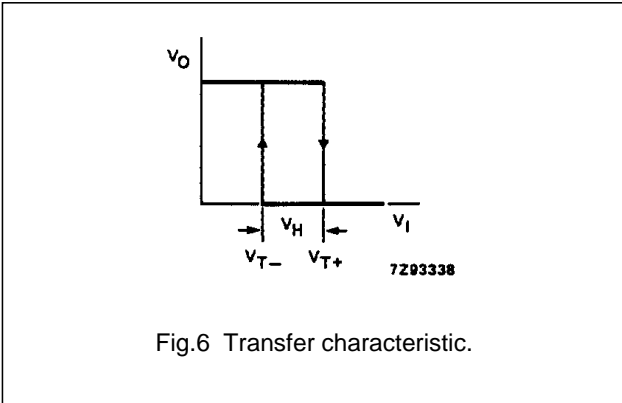

AC WAVEFORMS

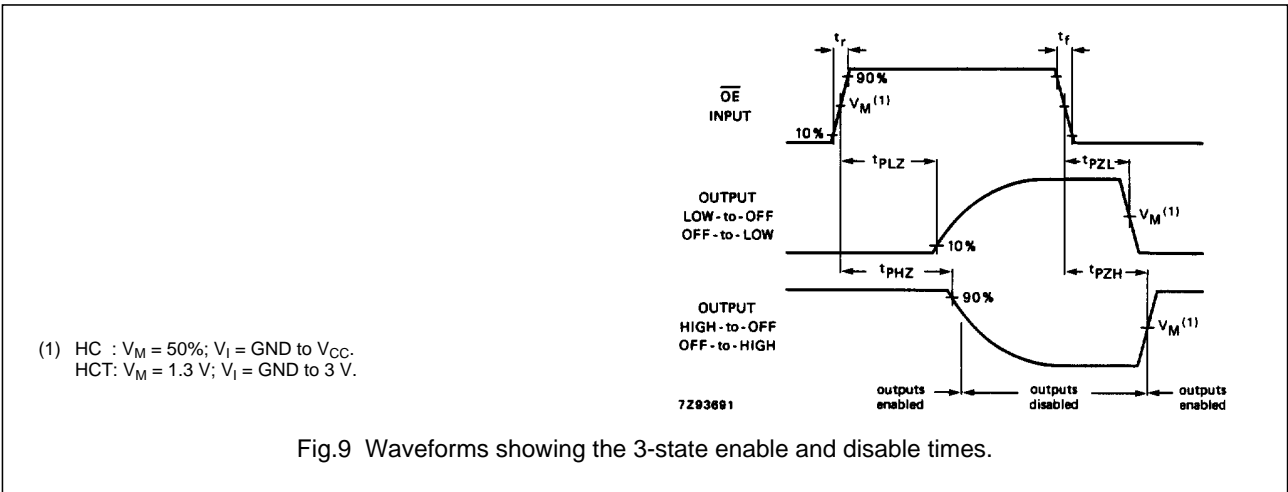
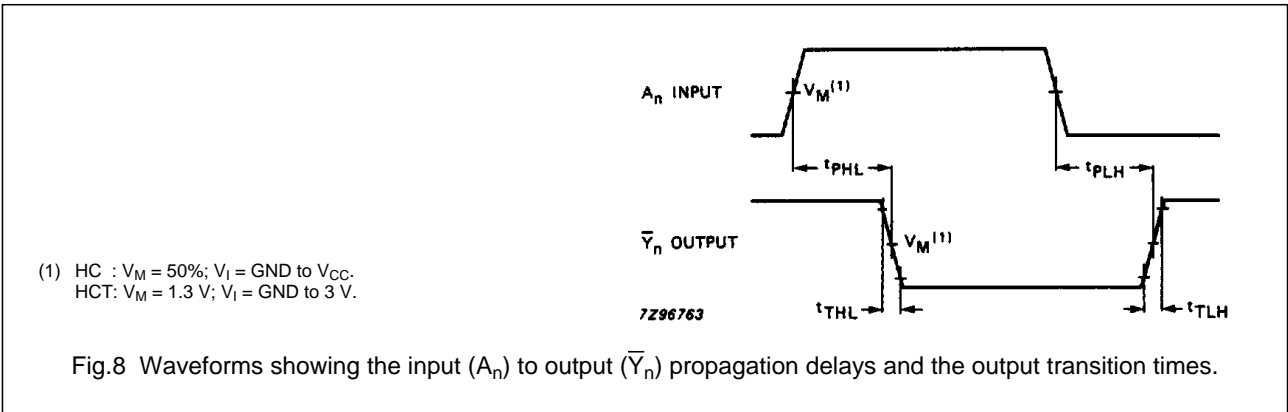

PACKAGE OUTLINES

See "74HC/HCT/HCU/HCMOS Logic Package Outlines".