

# Quad high-performance operational amplifier

# NE/SE5514

## DESCRIPTION

The NE/SE5514 family of quad operational amplifiers sets new standards in bipolar quad amplifier performance. The amplifiers feature low input bias current and low offset voltages. Pinout is identical to LM324/LM348 which facilitates direct product substitution for improved system performance in dual supply applications. Output characteristics are similar to a  $\mu A741$  with improved slew and drive capability.

## FEATURES

- Low input bias current:  $< \pm 3nA$
- Low input offset current:  $< \pm 3nA$
- Low input offset voltage:  $< 1mV$
- Low supply current:  $1.5mA/A$
- $1V/\mu s$  slew rate
- High input impedance:  $100M\Omega$
- High common-mode impedance:  $10G\Omega$
- Internal compensation for unity gain
- $600\Omega$  drive capability ( $7V_{RMS}$ )

## APPLICATIONS

- AC amplifiers
- RC active filters
- Transducer amplifiers
- DC gain block
- Instrumentation amplifier

## ORDERING INFORMATION

DESCRIPTION	TEMPERATURE RANGE	ORDER CODE	DWG #
16-Pin Plastic Small Outline Large (SOL) package	0 to $+70^{\circ}C$	NE5514D	0171B
14-Pin Plastic Dual In-Line Package (DIP)	0 to $+70^{\circ}C$	NE5514N	0405B
14-Pin Plastic Dual In-Line Package (DIP)	$-55$ to $+125^{\circ}C$	SE5514N	0405B

## PIN CONFIGURATIONS

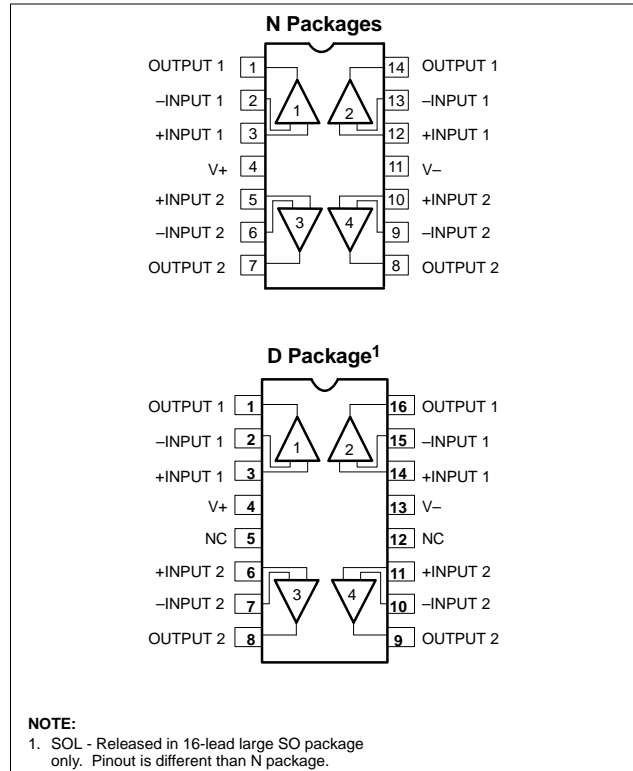

# Quad high-performance operational amplifier

NE/SE5514

## EQUIVALENT SCHEMATIC

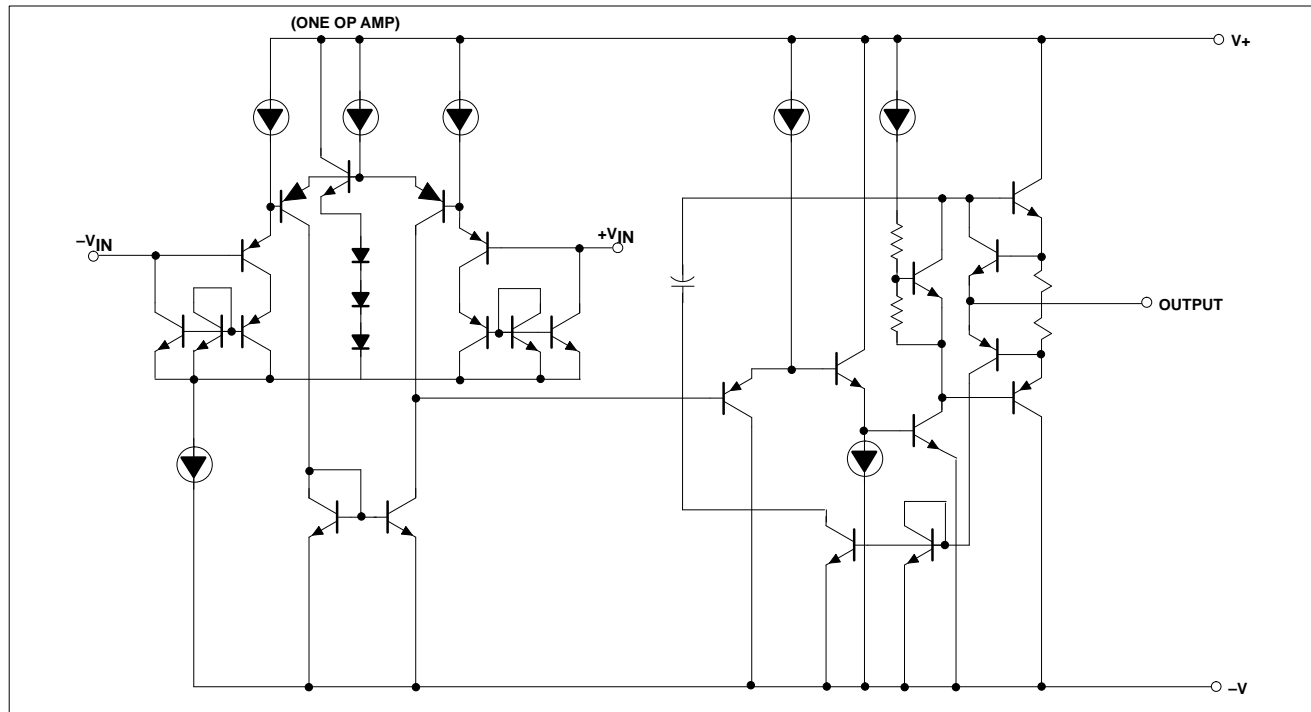

## ABSOLUTE MAXIMUM RATINGS

SYMBOL	PARAMETER	RATING	UNIT
V <sub>CC</sub>	Supply voltage	±16	V
V <sub>DIFF</sub>	Differential input voltage	32	V
V <sub>IN</sub>	Input voltage	0 to 32	V
	Output short to ground	Continuous	
T <sub>STG</sub>	Storage temperature range	-65 to +150	°C
T <sub>SOLD</sub>	Lead soldering temperature (10sec max)	300	°C
T <sub>A</sub>	Operating ambient temperature range		
	NE5514	0 to 70	°C
	SE5514	-55 to +125	°C
P <sub>MAX</sub>	Maximum power dissipation		
	T <sub>A</sub> =25°C (still-air) <sup>1</sup>		
	N package	1420	mW
	D package	1250	mW

### NOTES:

- The following derating factors should be applied above 25°C
  - N package at 11.4mW/°C
  - D package at 10.0mW/°C

## Quad high-performance operational amplifier

NE/SE5514

**ELECTRICAL CHARACTERISTICS** $V_{CC} = \pm 15V$ ,  $T_A = 25^\circ C$  unless otherwise specified.

SYMBOL	PARAMETER	TEST CONDITIONS	SE5514			NE5514			UNIT
			Min	Typ	Max	Min	Typ	Max	
$V_{OS}$	Input offset voltage	$R_S=100\Omega$ , $T_A=+25^\circ C$ Over temp.		0.7 1	2 3		1 1.5	5 6	mV
$\Delta V_{OS}$		Over temp.		4			5		$\mu V/^\circ C$
$I_{OS}$	Input offset current	$R_S=100k\Omega$ , $T_A=+25^\circ C$ Over temp.		3 4	10 20		6 8	20 30	nA
$\Delta I_{OS}$		Over temp.		30			40		$pA/^\circ C$
$I_{BIAS}$	Input bias current	$R_S=100k\Omega$ , $T_A=+25^\circ C$ Over temp.		3 4	10 20		6 8	20 30	nA
$\Delta I_{BIAS}$		Over temp.		30			40		$pA/^\circ C$
$R_{IN}$	Input resistance differential	$T_A=25^\circ C$		100			100		M $\Omega$
$V_{CM}$	Input common mode range	$T_A=25^\circ C$ Over temp.	$\pm 13.5$ $\pm 13$	$\pm 13.7$ $\pm 13.2$		$\pm 13.5$ $\pm 13$	$\pm 13.7$ $\pm 13.2$		V
CMRR	Input common-mode rejection ratio	$V_{CC}=\pm 15V$ , $V_{IN}=\pm 13.5V$ @ $T_A=25^\circ C$ $V_{IN}=\pm 13V$ @ Over temp.	70	100		70	100		dB
$A_V$	Large-signal voltage gain	$R_L=2k\Omega$ , $T_A=25^\circ C$ $V_O = \pm 10V$ , Over temp.	50 25	200		50 25	200		V/mV
SR	Slew rate	$T_A=25^\circ C$	0.6	1		0.6	1		V/ $\mu s$
GBW	Small-signal unity gain bandwidth	$T_A=25^\circ C$		3			3		MHz
$\theta_M$	Phase margin	$T_A=25^\circ C$		45			45		Deg
$V_{OUT}$	Output voltage swing	$R_L=2k\Omega$ , $T_A=25^\circ C$ Over temp.	$\pm 13$ $\pm 12.5$	$\pm 13.5$ $\pm 13$		$\pm 13$ $\pm 12.5$	$\pm 13.5$ $\pm 13$		V
$V_{OUT}$	Output voltage swing	$R_L=600\Omega^1$ , $T_A=25^\circ C$ Over temp.	$\pm 10$ $\pm 7.5$	$\pm 11.5$ $\pm 9$		$\pm 10$ $\pm 8$	$\pm 11.5$ $\pm 9$		V
$I_{CC}$	Power supply current	$R_L=Open$ , $T_A=25^\circ C$ Over temp.		6 7	10 12		6 7	10 12	mA
PSRR	Power supply rejection ratio	$\pm 5V \leq V_{CC} \leq \pm 15V$ Over temp.	80	110		80	110		dB
AA	Amplifier to amplifier coupling	$f=1kHz$ to $20kHz$ , $T_A=25^\circ C$		-120			-120		dB
THD	Total harmonic distortion	$f=10kHz$ , $T_A=25^\circ C$ $V_O=7V_{RMS}$		0.01			0.01		%
$V_{NOISE}$	Input noise voltage	$f=1kHz$ , $T_A=25^\circ C$		30			30		nV/ $\sqrt{Hz}$
$I_{SC}$	Short-circuit current	$T_A=25^\circ C$	10	40	60	10	40	60	mA

**NOTES:**

1. Not to exceed maximum power dissipation.