

DATA SHEET

BLT71 UHF power transistor

Product specification

1995 Aug 17

UHF power transistor

BLT71

FEATURES

- Very high efficiency
- Low supply voltage.

APPLICATIONS

- Hand-held radio equipment in common emitter class-AB operation in the 900 MHz communications band.

DESCRIPTION

NPN silicon planar epitaxial transistor encapsulated in a SOT223 envelope.

PINNING - SOT223

PIN	SYMBOL	DESCRIPTION
1	e	emitter
2	b	base
3	e	emitter
4	c	collector

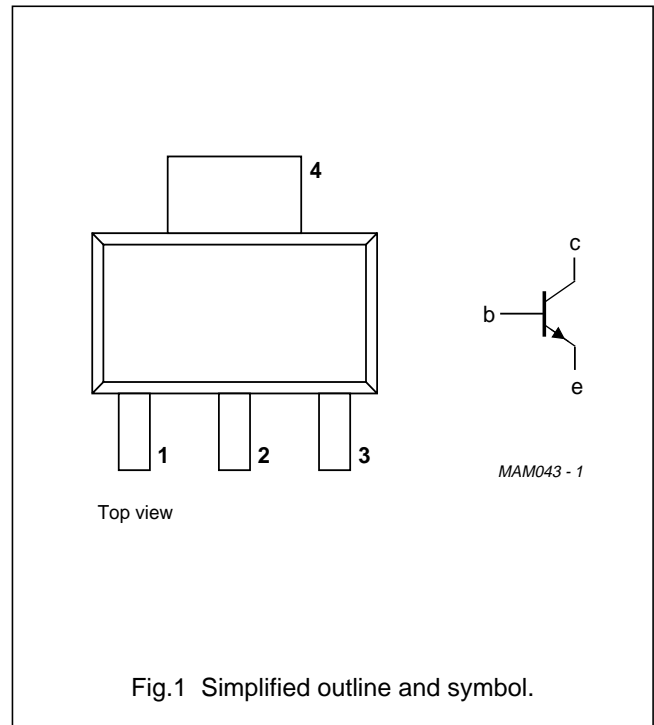

QUICK REFERENCE DATA

RF performance at $T_s \leq 60 \text{ }^\circ\text{C}$ in a common emitter test circuit.

MODE OF OPERATION	f (MHz)	V _{CE} (V)	P _L (W)	G _p (dB)	η_c (%)
CW, class-AB	900	4.8	1.2	≥ 6	≥ 60

UHF power transistor

BLT71

LIMITING VALUES

In accordance with the Absolute Maximum Rating System (IEC 134).

SYMBOL	PARAMETER	CONDITIONS	MIN.	MAX.	UNIT
V_{CBO}	collector-base voltage	open emitter	–	16	V
V_{CEO}	collector-emitter voltage	open base	–	8	V
V_{EBO}	emitter-base voltage	open collector	–	2.5	V
I_C	collector current (DC)		–	500	mA
P_{tot}	total power dissipation	up to $T_s = 90\text{ °C}$	–	3.5	W
T_{stg}	storage temperature		–65	+150	°C
T_j	operating junction temperature		–	175	°C

THERMAL CHARACTERISTICS

SYMBOL	PARAMETER	CONDITIONS	VALUE	UNIT
$R_{th\ j-s}$	thermal resistance from junction to soldering point	$P_{tot} = 3.5\text{ W}$; up to $T_s = 90\text{ °C}$; note 1	24	K/W

Note

- T_s is the temperature at the soldering point of the collector lead.

CHARACTERISTICS $T_j = 25\text{ °C}$ unless otherwise specified.

SYMBOL	PARAMETER	CONDITIONS	MIN.	TYP.	MAX.	UNIT
$V_{(BR)CBO}$	collector-base breakdown voltage	open emitter; $I_C = 0.5\text{ mA}$	16	–	–	V
$V_{(BR)CEO}$	collector-emitter breakdown voltage	open base; $I_C = 10\text{ mA}$	8	–	–	V
$V_{(BR)EBO}$	emitter-base breakdown voltage	open collector; $I_E = 0.1\text{ mA}$	2.5	–	–	V
I_{CES}	collector leakage current	$V_{CE} = 8\text{ V}$; $V_{BE} = 0$	–	–	100	μA
h_{FE}	DC current gain	$V_{CE} = 5\text{ V}$; $I_C = 100\text{ mA}$	25	–	–	
C_c	collector capacitance	$V_{CB} = 4.8\text{ V}$; $I_E = i_e = 0$; $f = 1\text{ MHz}$	–	–	7	pF
C_{re}	feedback capacitance	$V_{CE} = 4.8\text{ V}$; $I_C = 0$; $f = 1\text{ MHz}$	–	–	5	pF

UHF power transistor

BLT71

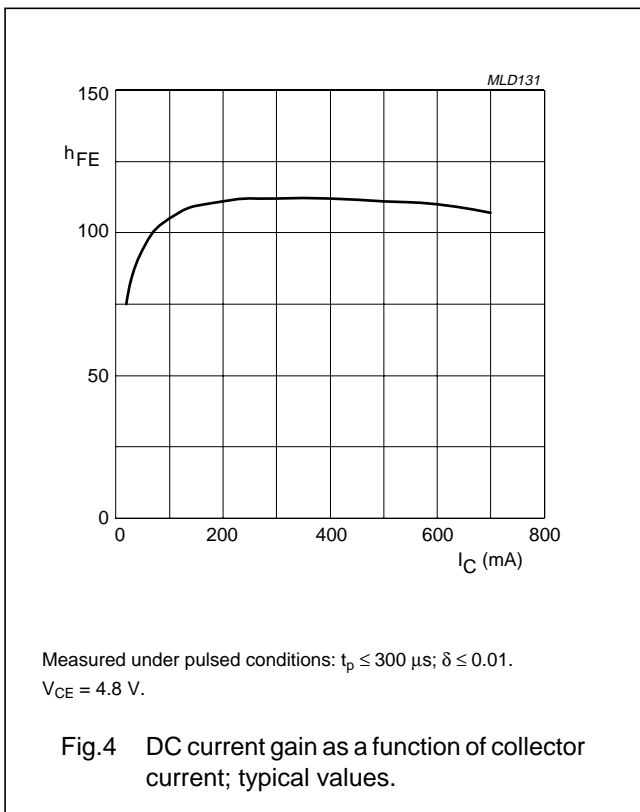
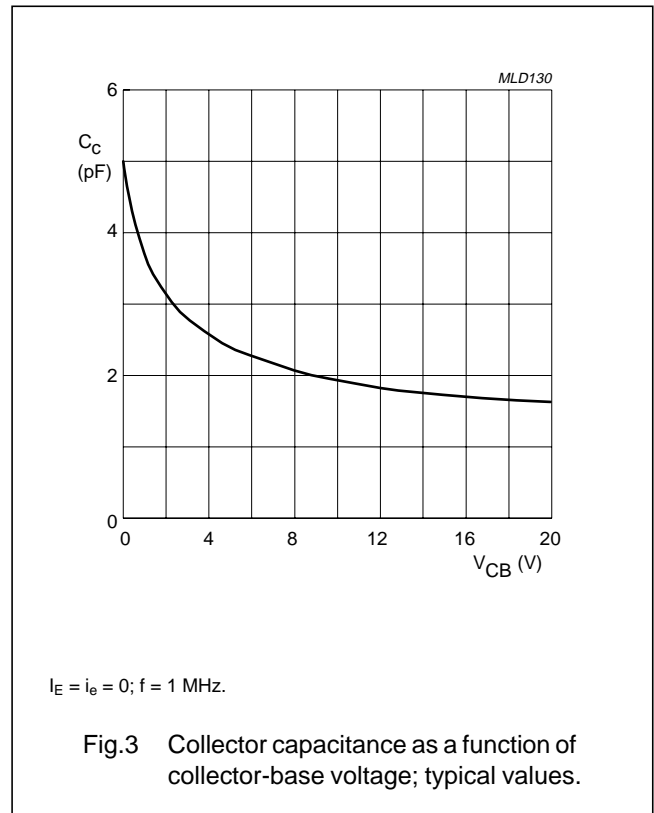
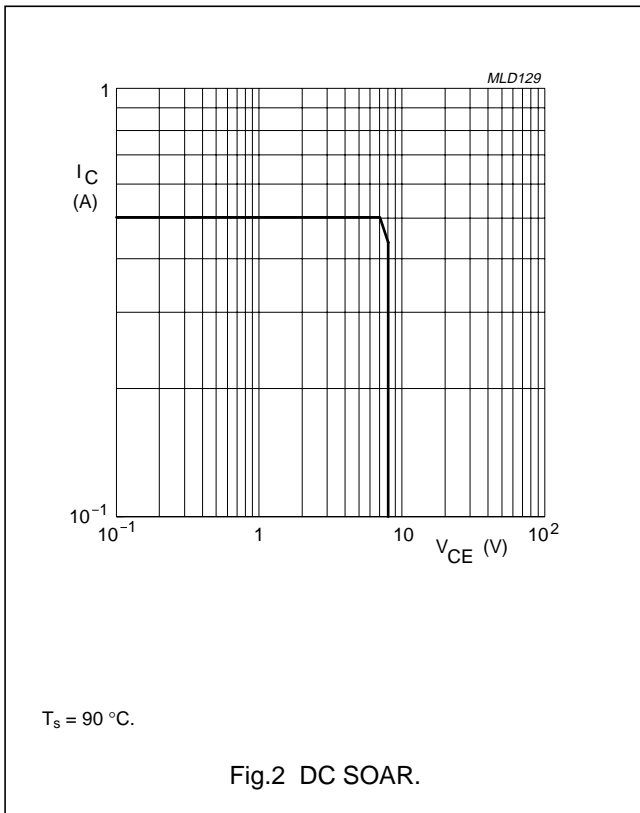

UHF power transistor

BLT71

APPLICATION INFORMATION

RF performance at $T_s \leq 60^\circ\text{C}$ in a common emitter test circuit.

MODE OF OPERATION	f (MHz)	V _{CE} (V)	I _{CQ} (mA)	P _L (W)	G _p (dB)	η _c (%)
CW, class-AB	900	4.8	1	1.2	≥6	≥60

Ruggedness in class-AB operation

The BLT71 is capable of withstanding a load mismatch corresponding to VSWR = 6 : 1 through all phases under the following conditions: P_L = 1.2 W; V_{CE} = 6.5 V; f = 900 MHz.

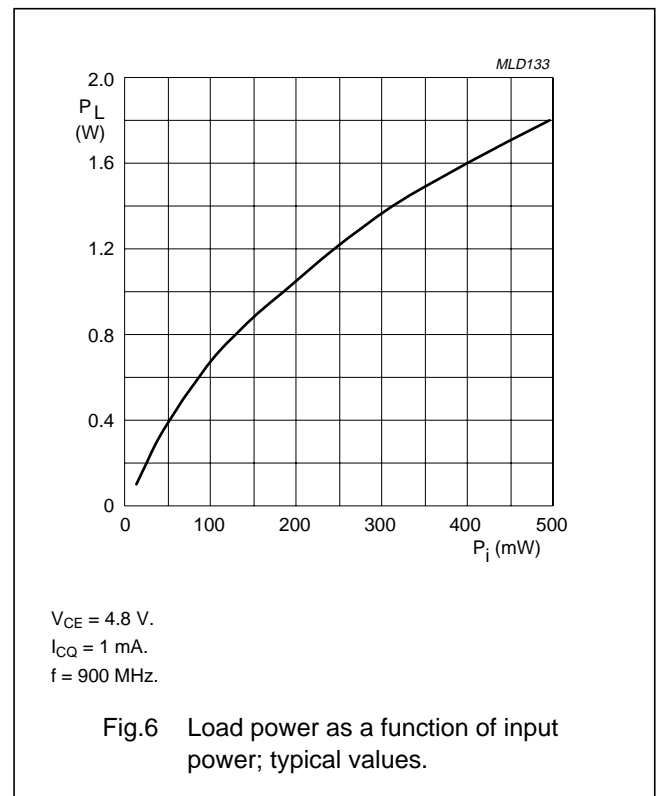
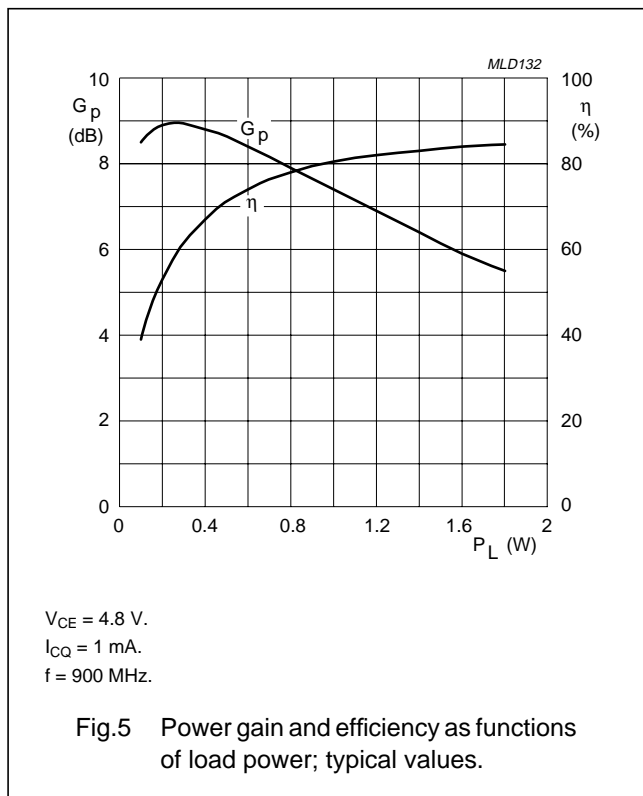

UHF power transistor

BLT71

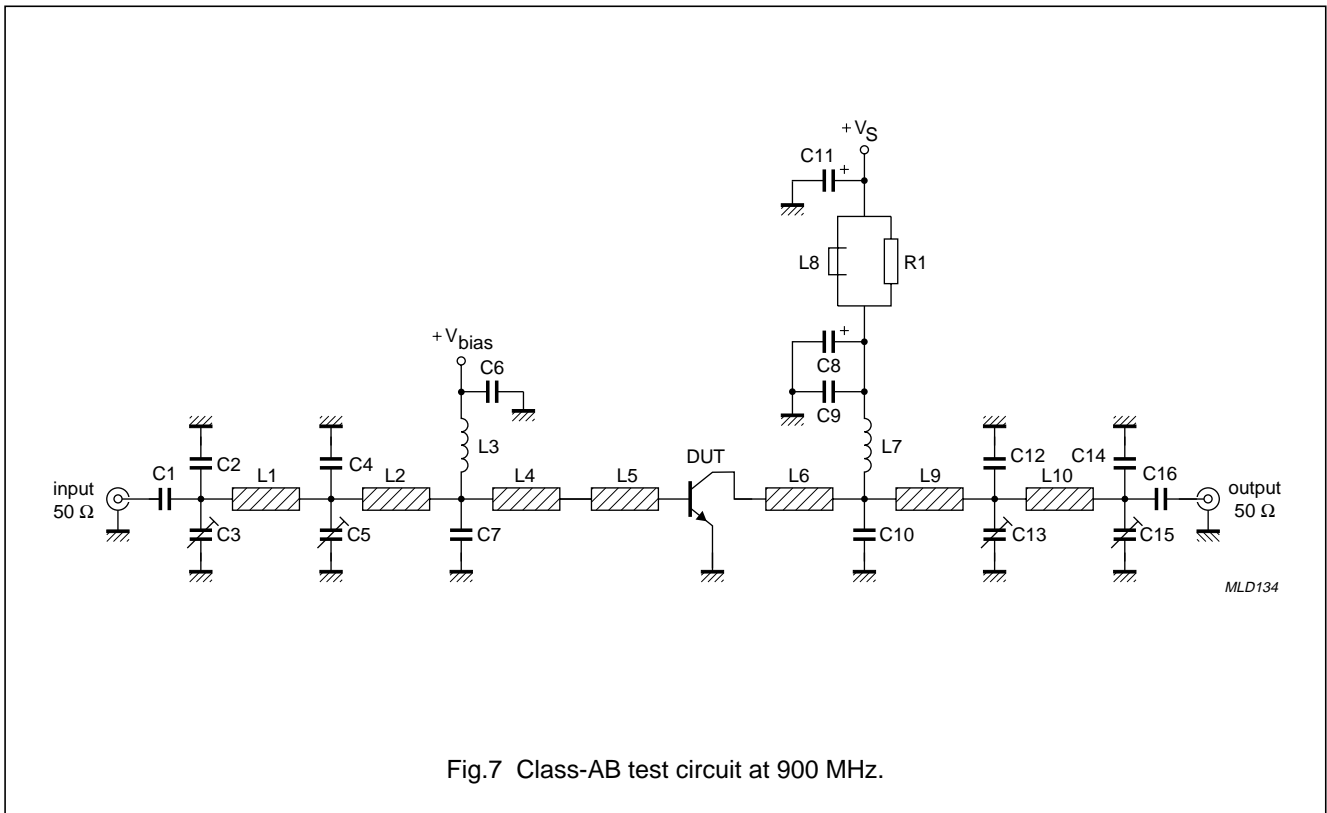

UHF power transistor

BLT71

List of components (see Figs 7 and 8)

COMPONENT	DESCRIPTION	VALUE	DIMENSIONS	CATALOGUE No.
C1, C6, C9, C16	multilayer ceramic chip capacitor; note 1	100 pF		
C2, C4, C12, C14	multilayer ceramic chip capacitor; note 1	1 pF		
C3, C5, C13, C15	film dielectric trimmer	1.4 to 5.5 pF		2222 809 09004
C7	multilayer ceramic chip capacitor; note 1	6.8 pF		
C8	tantalum capacitor	1 μ F, 35 V		
C10	multilayer ceramic chip capacitor; note 1	5.1 pF		
C11	tantalum capacitor	100 μ F, 20 V		
L1	stripline; note 2	50 Ω	length 28.5 mm width 5 mm	
L2	stripline; note 2	50 Ω	length 23 mm width 5 mm	
L3	11 turns enamelled 0.6 mm copper wire	100 nH	length 7.5 mm internal dia. 3.3 mm	
L4	stripline; note 2	50 Ω	length 1 mm width 5 mm	
L5	stripline; note 2	50 Ω	length 3 mm width 2.5 mm	
L6	stripline; note 2	50 Ω	length 9 mm width 5 mm	
L7	7 turns enamelled 0.6 mm copper wire	37 nH	length 7.3 mm internal dia. 3.3 mm	
L8	grade 3B Ferroxcube wideband HF choke			4132 020 36640
L9	stripline; note 2	50 Ω	length 13.5 mm width 5 mm	
L10	stripline; note 2	50 Ω	length 26.5 mm width 5 mm	
R1	metal film resistor	0.1 W, 10 Ω		

Notes

- American Technical Ceramics type 100A or capacitor of same quality.
- The striplines are on a double copper-clad printed-circuit board, with DUROID dielectric ($\epsilon_r = 2.2$); thickness $\frac{1}{16}$ "; thickness of the copper sheet $2 \times 35 \mu\text{m}$.

UHF power transistor

BLT71

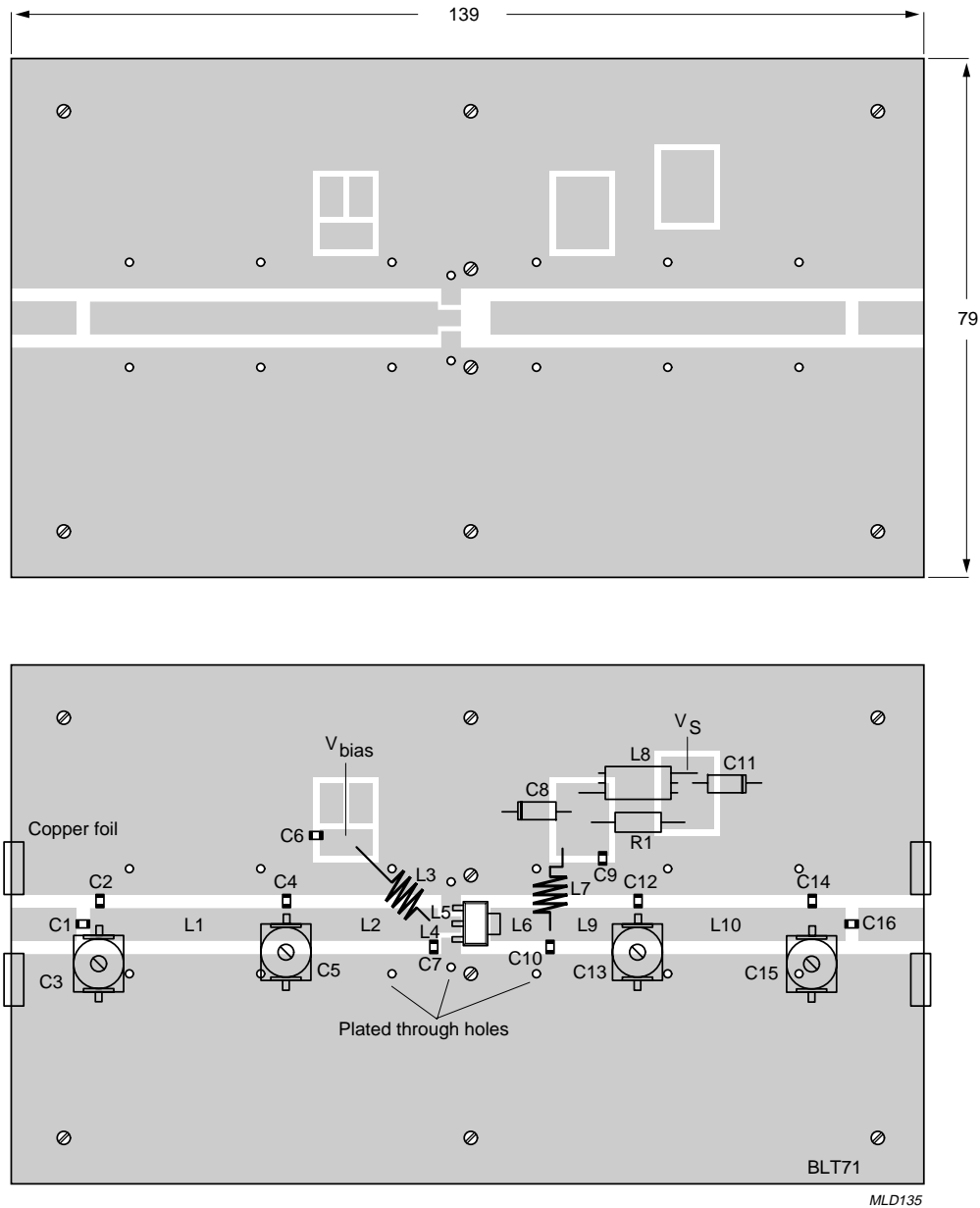

Dimensions in mm.

The components are situated on one side of the copper-clad PCB, the other side is unetched and serves as a ground plane. Earth connections from the component side to the ground plane are made by through metallization.

Fig.8 Component lay-out and printed-circuit board for 900 MHz class-AB test circuit.

UHF power transistor

BLT71

SPICE parameters for the BLT71 crystal

SEQUENCE No.	PARAMETER	VALUE	UNIT
1	IS	3.503	fA
2	BF	190.5	–
3	NF	0.981	–
4	VAF	35.45	V
5	IKF	24.52	A
6	ISE	184.9	fA
7	NE	1.475	–
8	BR	12.61	–
9	NR	1.042	–
10	VAR	1.476	V
11	IKR	2.206	A
12	ISC	866.5	aA
13	NC	1.025	–
14	RB	2.000	Ω
15	IRB	1.000	μA
16	RBM	2.000	Ω
17	RE	373.8	mΩ
18	RC	330.6	mΩ
19 ⁽¹⁾	XTB	0.000	–
20 ⁽¹⁾	EG	1.110	eV
21 ⁽¹⁾	XTI	3.000	–
22	CJE	9.746	pF
23	VJE	0.600	V
24	MJE	0.288	–
25	TF	11.99	ps
26	XTF	0.979	–
27	VTF	19.52	mV
28	ITF	0.137	A
29	PTF	0.000	deg
30	CJC	5.028	pF
31	VJC	0.609	V
32	MJC	0.368	–
33	XCJC	0.150	–
34	TR	3.841	ns
35 ⁽¹⁾	CJS	0.000	F
36 ⁽¹⁾	VJS	750.0	mV
37 ⁽¹⁾	MJS	0.000	–
38	FC	0.813	–

Note

1. These parameters have not been extracted, the default values are shown.

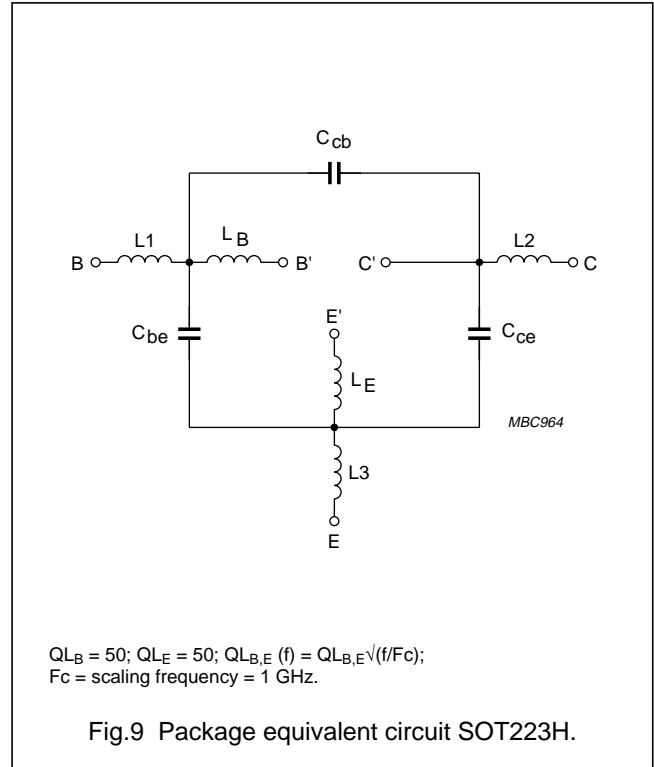

Fig.9 Package equivalent circuit SOT223H.

List of components (see Fig.9)

DESIGNATION	VALUE	UNIT
C _{be}	182	fF
C _{cb}	16	fF
C _{ce}	249	fF
L1	0.025	nH
L2	1.19	nH
L3	0.6	nH
L _B	1.85	nH
L _E	1.22	nH

UHF power transistor

BLT71

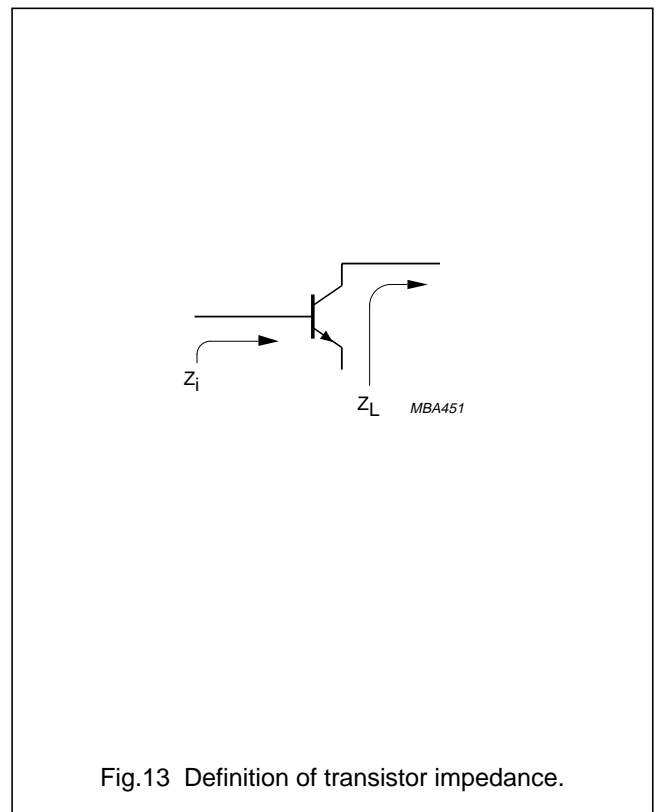
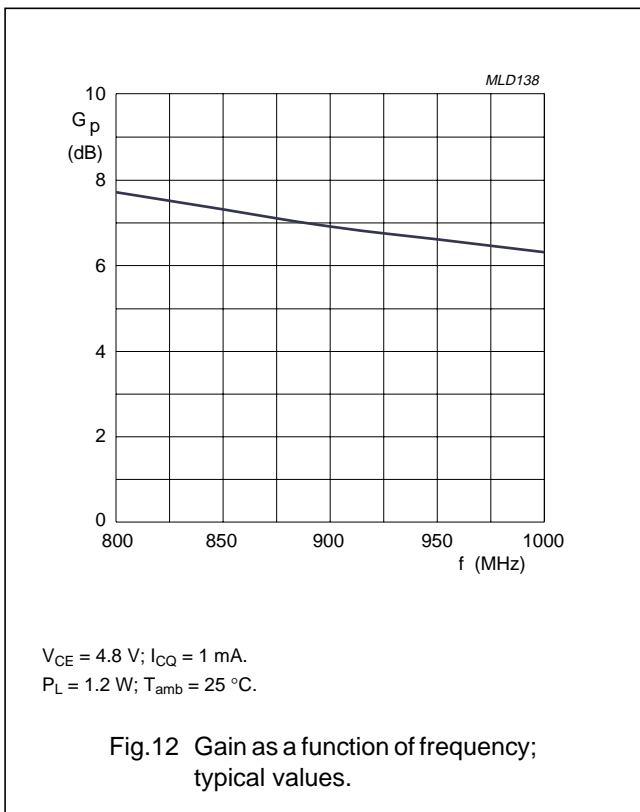
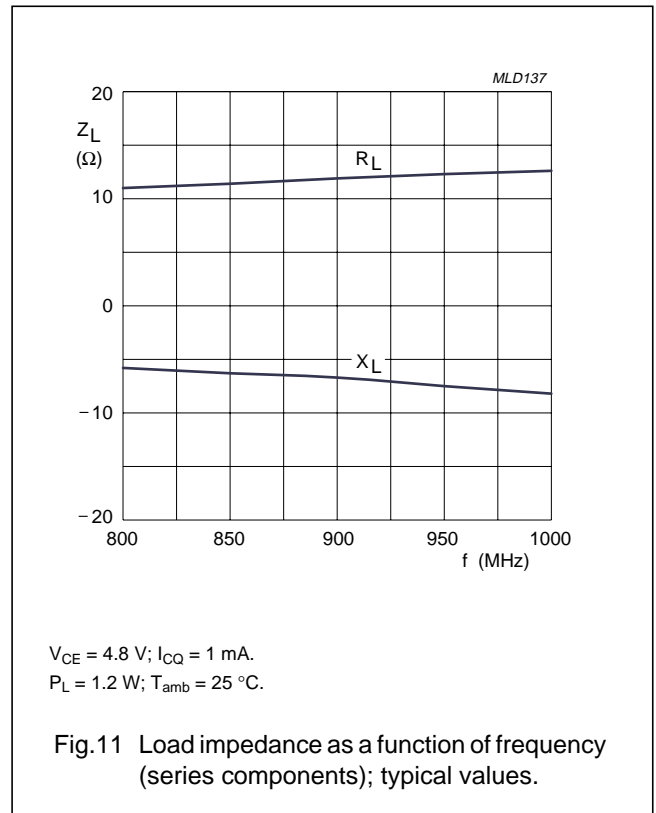
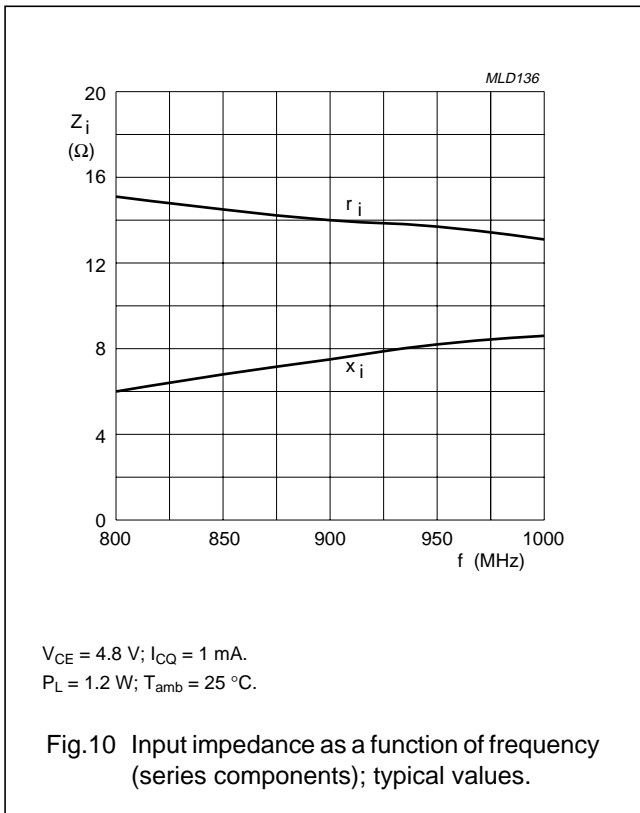

UHF power transistor

BLT71

DEFINITIONS

Data Sheet Status	
Objective specification	This data sheet contains target or goal specifications for product development.
Preliminary specification	This data sheet contains preliminary data; supplementary data may be published later.
Product specification	This data sheet contains final product specifications.
Limiting values	
Limiting values given are in accordance with the Absolute Maximum Rating System (IEC 134). Stress above one or more of the limiting values may cause permanent damage to the device. These are stress ratings only and operation of the device at these or at any other conditions above those given in the Characteristics sections of the specification is not implied. Exposure to limiting values for extended periods may affect device reliability.	
Application information	
Where application information is given, it is advisory and does not form part of the specification.	

LIFE SUPPORT APPLICATIONS

These products are not designed for use in life support appliances, devices, or systems where malfunction of these products can reasonably be expected to result in personal injury. Philips customers using or selling these products for use in such applications do so at their own risk and agree to fully indemnify Philips for any damages resulting from such improper use or sale.