

DATA SHEET



PCD5002A Enhanced Pager Decoder for APOC1/POCSAG

Product specification
File under Integrated Circuits, IC17

1999 Jan 08

Enhanced Pager Decoder for APOC1/POCSAG

PCD5002A

CONTENTS

1	FEATURES		
2	APPLICATIONS		
3	GENERAL DESCRIPTION		
4	ORDERING INFORMATION		
5	LICENSE		
6	BLOCK DIAGRAM		
7	PINNING		
8	FUNCTIONAL DESCRIPTION		
8.1	Introduction	8.41	Warbled alert
8.2	The POCSAG paging code	8.42	Direct alert control
8.3	The APOC1 paging code	8.43	Alert priority
8.4	Error correction	8.44	Cancelling alerts
8.5	Operating states	8.45	Automatic POCSAG alerts
8.6	ON status	8.46	SRAM access
8.7	OFF status	8.47	RAM write address pointer (06H; read)
8.8	Reset	8.48	RAM read address pointer (08H; read/write)
8.9	Bit rates	8.49	RAM data output register (09H; read)
8.10	Oscillator	8.50	EEPROM access
8.11	Input data processing	8.51	EEPROM address pointer (07H; read/write)
8.12	Battery saving	8.52	EEPROM data I/O register (0AH; read/write)
8.13	POCSAG synchronization strategy	8.53	EEPROM access limitations
8.14	APOC1 synchronization strategy	8.54	EEPROM read operation
8.15	Call termination	8.55	EEPROM write operation
8.16	Enhanced call termination	8.56	Invalid write address
8.17	Call data output format	8.57	Incomplete programming sequence
8.18	Error type indication	8.58	Unused EEPROM locations
8.19	Data transfer	8.59	Special programmed function allocation
8.20	Continuous data decoding	8.60	Synthesizer programming data
8.21	Receiver and oscillator control	8.61	Identifier storage allocation
8.22	Demodulator quick charge	8.62	Voltage doubler
8.23	External receiver control and monitoring	8.63	Level-shifted interface
8.24	Battery condition input	8.64	Signal test mode
8.25	Synthesizer control	9	OPERATING INSTRUCTIONS
8.26	Serial microcontroller interface	9.1	Reset conditions
8.27	Decoder I ² C-bus access	9.2	Power-on reset circuit
8.28	External interrupt	9.3	Reset timing
8.29	Interrupt masking	9.4	Initial programming
8.30	Status/control register	10	LIMITING VALUES
8.31	Pending interrupts	11	DC CHARACTERISTICS
8.32	Out-of-range indication	12	DC CHARACTERISTICS (WITH VOLTAGE CONVERTER)
8.33	Real-time clock	13	OSCILLATOR CHARACTERISTICS
8.34	Periodic interrupt	14	AC CHARACTERISTICS
8.35	Received call delay	15	APPLICATION INFORMATION
8.36	Alert generation	16	PACKAGE OUTLINE
8.37	Alert cadence register (03H; write)	17	SOLDERING
8.38	Acoustic alert	17.1	Introduction to soldering surface mount packages
8.39	Vibrator alert	17.2	Reflow soldering
8.40	LED alert	17.3	Wave soldering
		17.4	Manual soldering
		17.5	Suitability of surface mount IC packages for wave and reflow soldering methods
		18	DEFINITIONS
		19	LIFE SUPPORT APPLICATIONS
		20	PURCHASE OF PHILIPS I ² C COMPONENTS

Enhanced Pager Decoder for APOC1/POCSAG

PCD5002A



1 FEATURES

- Wide operating supply voltage range: 1.5 to 6.0 V
- EEPROM programming requires only 2.0 V supply
- Low operating current: 50 μ A typ. (ON), 25 μ A typ. (OFF)
- Temperature range -25 to $+70$ °C
- "CCIR radio paging Code No. 1" (POCSAG) compatible
- Supports Advanced Pager Operator's Code Phase 1 (APOC1) for extended battery economy
- 512, 1200 and 2400 bits/s data rates using 76.8 kHz crystal
- Built-in data filter (16 times oversampling) and bit clock recovery
- Advanced ACCESS[®] synchronization algorithm
- 2-bit random and (optional) 4-bit burst error correction
- Up to 6 user addresses Receiver Identity Codes (RICs), each with 4 functions/alert cadences
- Optional automatic call termination when bit error rate is high
- Up to 6 user address frames, independently programmable
- Standard POCSAG sync word, plus up to 4 user programmable sync words
- Continuous data decoding upon reception of user programmable sync word (optional)
- Received data inversion (optional)
- Call alert via beeper, vibrator or LED
- 2-level acoustic alert using single external transistor
- Alert control: automatic (POCSAG type), via cadence register or alert input pin
- Separate power control of receiver and RF oscillator for battery economy
- Dedicated pin for easy control of superheterodyne receiver
- Synthesizer set-up and control interface (3-line serial)
- On-chip EEPROM for storage of user addresses (RICs), pager configuration and synthesizer data
- On-chip SRAM buffer for message data
- Slave I²C-bus interface to microcontroller for transfer of message data, status/control and EEPROM programming (data transfer at up to 100 kbits/s)
- Wake-up interrupt for microcontroller, programmable polarity
- Direct and I²C-bus control of operating status (ON/OFF)
- Battery-low indication (external detector)
- Out-of-range condition indication
- Real-time clock reference output
- On-chip voltage doubler
- Interfaces directly to UAA2080 and UAA2082 paging receivers.

2 APPLICATIONS

- Advanced display pagers (POCSAG and APOC1)
- Basic alert-only pagers
- Information services
- Personal organizers
- Telepoint
- Telemetry/data transmission.

3 GENERAL DESCRIPTION

The PCD5002A is a very low power pager decoder and controller, capable of handling both standard POCSAG and the advanced APOC1 code. Continuous data decoding upon reception of a dedicated sync word is available for news pager applications.

Data rates supported are 512, 1200 and 2400 bits/s using a single 76.8 kHz crystal. On-chip EEPROM is programmable using a minimum supply voltage of 2.0 V, allowing 'over-the-air' programming. I²C-bus compatible.

4 ORDERING INFORMATION

TYPE NUMBER	PACKAGE		
	NAME	DESCRIPTION	VERSION
PCD5002AH	LQFP32	plastic low profile quad flat package; 32 leads; body 7 × 7 × 1.4 mm	SOT358-1

Enhanced Pager Decoder for APOC1/POCSAG

PCD5002A

5 LICENSE

Supply of this IC does neither convey nor express an implied license under any patent right to use this in any APOC application.

6 BLOCK DIAGRAM

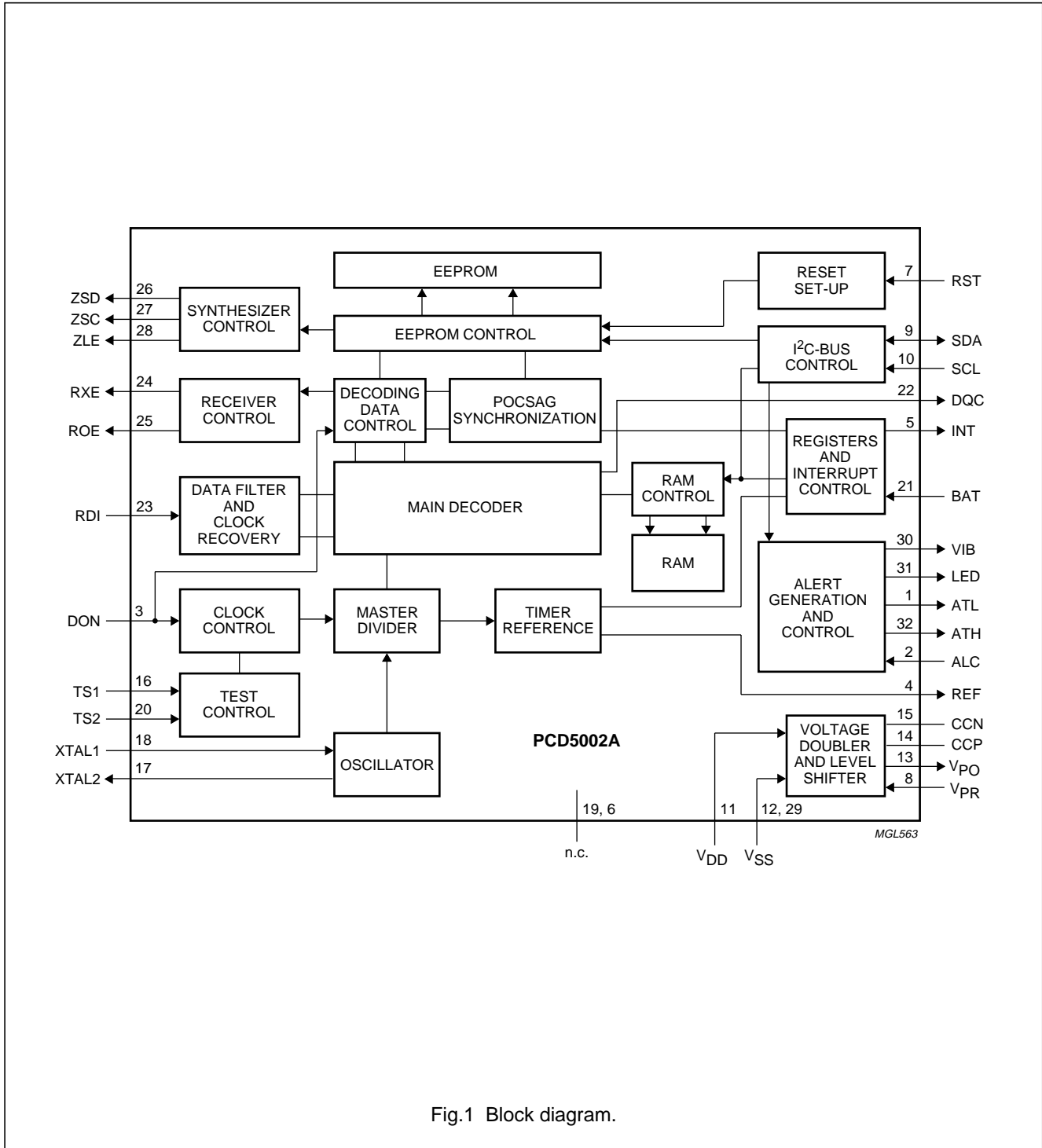

Fig.1 Block diagram.

Enhanced Pager Decoder for APOC1/POCSAG

PCD5002A

7 PINNING

SYMBOL	PIN	DESCRIPTION
ATL	1	alert LOW level output
ALC	2	alert control input (normally LOW by internal pull-down)
DON	3	direct ON/OFF input (normally LOW by internal pull-down)
REF	4	real-time clock frequency reference output
INT	5	interrupt output
n.c.	6	not connected
RST	7	reset input (normally LOW by internal pull-down)
V _{PR}	8	external positive voltage reference input
SDA	9	I ² C-bus serial data input/output
SCL	10	I ² C-bus serial clock input
V _{DD}	11	main positive supply voltage
V _{SS}	12	main negative supply voltage
V _{PO}	13	voltage converter positive output
CCP	14	voltage converter shunt capacitor (positive side)
CCN	15	voltage converter shunt capacitor (negative side)

SYMBOL	PIN	DESCRIPTION
TS1	16	test input 1 (normally LOW by internal pull-down)
XTAL2	17	decoder crystal oscillator output
XTAL1	18	decoder crystal oscillator input
n.c.	19	not connected
TS2	20	test input 2 (normally LOW by internal pull-down)
BAT	21	battery sense input
DQC	22	demodulator quick charge output
RDI	23	received data input (POCSAG or APOC1)
RXE	24	receiver circuit enable output
ROE	25	receiver oscillator enable output
ZSD	26	synthesizer serial data output
ZSC	27	synthesizer serial clock output
ZLE	28	synthesizer latch enable output
V _{SS}	29	main negative supply voltage
VIB	30	vibrator motor drive output
LED	31	LED drive output
ATH	32	alert HIGH level output

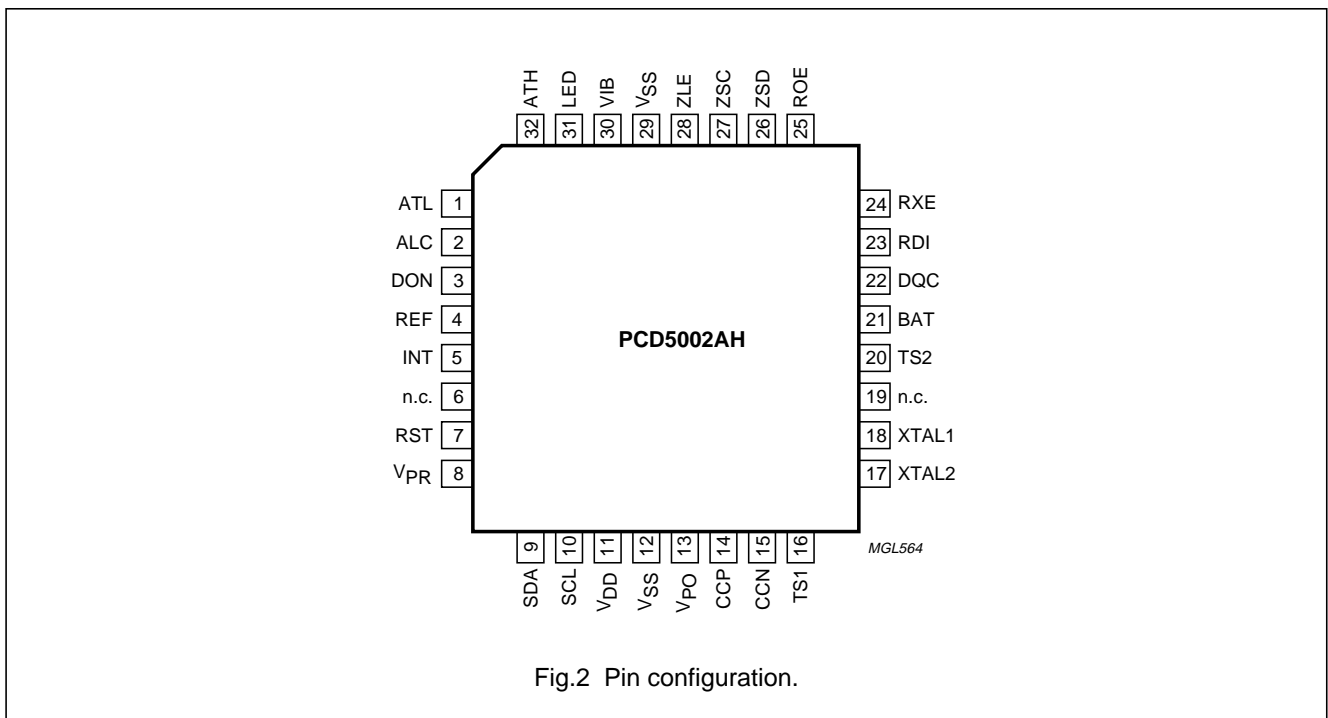

Fig.2 Pin configuration.

Enhanced Pager Decoder for APOC1/POCSAG

PCD5002A

8 FUNCTIONAL DESCRIPTION

8.1 Introduction

The PCD5002A is a very low power decoder and pager controller specifically designed for use in new generation radio pagers. The architecture of the PCD5002A allows for flexible application in a wide variety of radio pager designs.

The PCD5002A is fully compatible with "CCIR Radio paging Code No. 1" (also known as the POCSAG code) operating at data rates of 512, 1200 and 2400 bits/s using a single oscillator crystal of 76.8 kHz.

The PCD5002A also supports the new Advanced Pager Operator's Code Phase 1 (APOC1). This compatible extension to the POCSAG code improves battery economy by introducing 'cycles' and batch numbering. A cycle consists of 5 or 15 standard POCSAG batches. Each pager will be allocated a batch number in addition to its POCSAG address and it will only search for its address during this batch.

In addition to the standard POCSAG sync word (used also in APOC1) the PCD5002A is also capable of recognizing up to 4 User Programmable Sync Words (UPSWs). This permits the reception of both private services and POCSAG or APOC1 transmissions via the same radio channel. As an option reception of a UPSW may activate Continuous Data Decoding (CDD).

Used together with the Philips UAA2080 or UAA2082 paging receiver, the PCD5002A offers a highly sophisticated, miniature solution for the radio paging market. Control of an RF synthesizer circuit is also provided to ease alignment and channel selection.

On-chip EEPROM provides storage for user addresses (Receiver Identity Codes or RICs) and Special Programmed Functions (SPFs) and UPSWs, which eliminates the need for external storage devices and interconnection. For other non-volatile storage 20 bytes of general purpose EEPROM are available. The low EEPROM programming voltage makes the PCD5002A well suited for 'over-the-air' programming/reprogramming.

On request from an external controlling device or automatically (by SPF programming), the PCD5002A will provide standard POCSAG alert cadences by driving a standard acoustic 'beeper'. Non-standard alert cadences may be generated via a cadence register or a dedicated control input.

The PCD5002A can also produce a HIGH level acoustic alert as well as drive an LED indicator and a vibrator motor via external bipolar transistors.

The PCD5002A contains a low-power, high-efficiency voltage converter (doubler) designed to provide a higher voltage supply to LCD drivers or microcontrollers. In addition, an independent level shifted interface is provided allowing communication to a microcontroller operating at a higher voltage than the PCD5002A.

Interface to such an external device is provided by an I²C-bus which allows received call identity and message data, data for the programming of the internal EEPROM, alert control and pager status information to be transferred between the devices. Pager status includes features provided by the PCD5002A such as battery-low and out-of-range indications. A dedicated interrupt line minimizes the required microcontroller activity.

A selectable low frequency timing reference is provided for use in real-time clock functions.

Data synchronization is achieved by the Philips patented ACCESS[®] algorithm ensuring that maximum advantage is made of the POCSAG code structure particularly in fading radio signal conditions. The algorithm allows for data synchronization without preamble detection whilst minimizing battery power consumption. The APOC1 code uses an extended version of the ACCESS[®] synchronization algorithm.

Random (and optional) burst error correction techniques are applied to the received data to optimize the call success rate without increasing the falsing rate beyond specified POCSAG levels.

8.2 The POCSAG paging code

A transmission using the "CCIR Radio paging Code No. 1" (POCSAG code) is constructed in accordance with the following rules (see Fig.3).

The transmission is started by sending a **preamble**, consisting of at least 576 continuously alternating bits (10101010...). The preamble is followed by an arbitrary number of batch blocks. Only complete batches are transmitted.

Each **batch** comprises 17 code-words of 32 bits each. The first code-word is a synchronization code-word with a fixed pattern. The **sync** word is followed by 8 frames (0 to 7) of 2 code-words each, containing message information. A code-word in a frame can either be an address, message or idle code-word.

Idle code-words also have a fixed pattern and are used to fill empty frames or to separate messages.

Enhanced Pager Decoder for APOC1/POCSAG

PCD5002A

Address code-words are identified by an MSB at logic 0 and are coded as shown in Fig.3. A user address or RIC consists of 21 bits. Only the upper 18 bits are encoded in the address code-word (bits 2 to 19). The lower 3 bits designate the frame number (0 to 7) in which the address is transmitted.

Four different call types ('numeric', 'alphanumeric' and two 'alert only' types) can be distinguished. The call type is determined by two function bits in the address code-word (bits 20 and 21), as shown in Table 1.

Alert-only calls consist only of a single address code-word. Numeric and alphanumeric calls have message code-words following the address. A message causes the frame structure to be temporarily suspended. Message code-words are sent until the message is completed, with only the sync words being transmitted in their expected positions.

Message code-words are identified by an MSB at logic 1 and are coded as shown in Fig.3. The message information is stored in a 20-bit field (bits 2 to 21).

The standard data format is determined by the call type: 4 bits per digit for numeric messages and 7 bits per (ASCII) character for alphanumeric messages.

Each code-word is protected against transmission errors by 10 CRC check bits (bits 22 to 31) and an even-parity bit (bit 32).

This permits correction of a maximum of 2 random errors or up to 3 errors in a burst of 4 bits (a 4-bit burst error) per code-word.

8.3 The APOC1 paging code

The APOC1 paging code is fully POCSAG compatible and involves the introduction of batch grouping and a Batch Zero Identifier (BZI). This reserved address code-word indicates the start of a 'cycle' of 5 or 15 batches long and is transmitted immediately after a sync word.

Cycle transmission must be coherent i.e. a transmission starting an integer number of cycle periods after the start of the previous one.

Broadcast message data may be included in a transmission. This information may occupy any number of message code-words and immediately follows the batch zero identifier of the first cycle after preamble.

The presence of data is indicated by the function bits in the batch zero identifier: 1,1 indicates 'no broadcast data'. Any other combination indicates a broadcast message.

The PCD5002A can be configured for POCSAG or APOC1 operation via SPF programming. The batch zero identifier is programmable and can be stored in any identifier location in EEPROM.

The POCSAG standard only allows combinations of data formats and function code bits as given in Table 1. However, other (non-standard) combinations will be decoded normally by the PCD5002A.

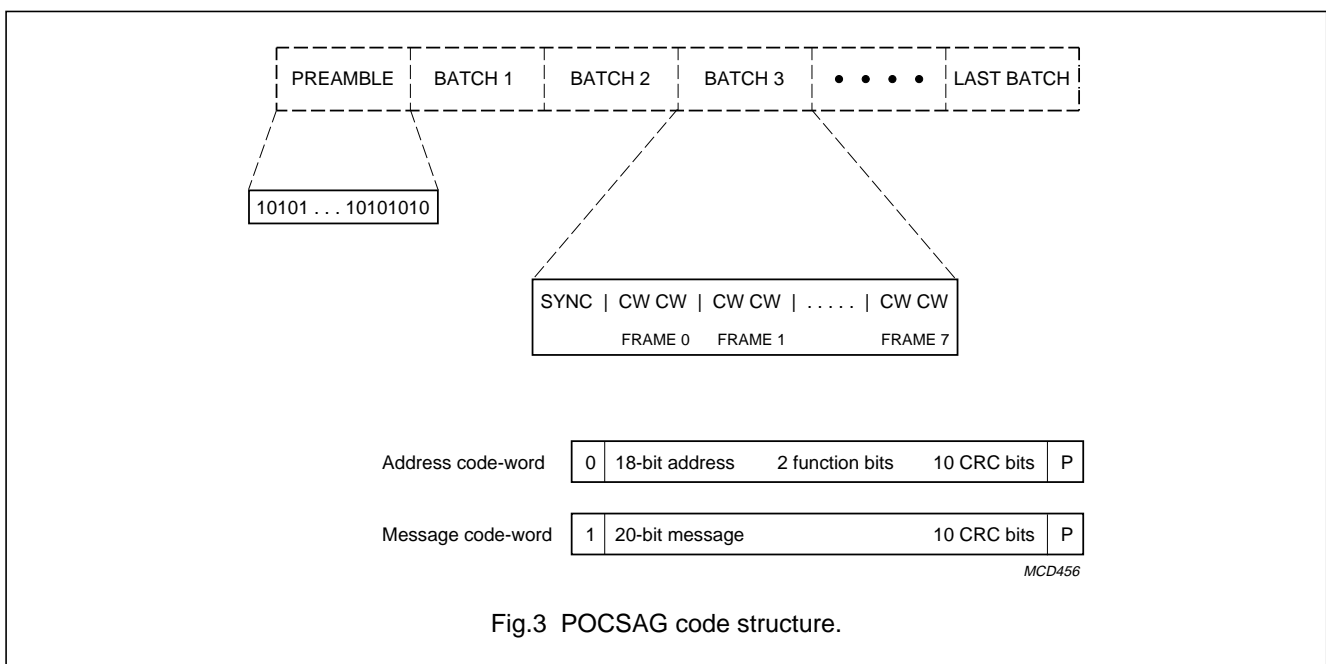

Fig.3 POCSAG code structure.

Enhanced Pager Decoder for APOC1/POCSAG

PCD5002A

Table 1 POCSAG recommended call types and function bits

BIT 20 (MSB)	BIT 21 (LSB)	CALL TYPE	DATA FORMAT
0	0	numeric	4-bits per digit
0	1	alert only 1	–
1	0	alert only 2	–
1	1	alphanumeric	7-bits per ASCII character

8.4 Error correction

In the PCD5002A error correction methods have been implemented as shown in Table 2.

Random error correction is default for both address and message code-words. In addition, burst error correction can be enabled by SPF programming. Up to 3 erroneous bits in a 4-bit burst can be corrected.

The error type detected for each code-word is identified in the message data output to the microcontroller, allowing rejection of calls with too many errors.

Table 2 Error correction

ITEM	CORRECTION
Preamble	4 random errors in 31 bits
Synchronization code-word	2 random errors in 32 bits
Address code-word	2 random errors; plus 4-bit burst errors (optional)
Message code-word	2 random errors; plus 4-bit burst errors (optional)

8.5 Operating states

The PCD5002A has 2 operating states:

- ON status
- OFF status.

The operating state is determined by a direct control input (DON) and bit D4 in the control register (see Table 3).

Table 3 Truth table for decoder operating status

DON INPUT	CONTROL BIT D4	OPERATING STATUS
0	0	OFF
0	1	ON
1	0	ON
1	1	ON

8.6 ON status

In the ON status the decoder pulses the receiver and oscillator enable outputs (RXE and ROE respectively) according to the code structure and the synchronization algorithm. Data received serially at the data input (RDI) is processed for call reception.

The data protocol can be POCSAG or APOC1. Continuous data decoding upon reception of a special sync word is also supported. The data protocol is selected by SPF programming.

Reception of a valid paging call is signalled to the microcontroller by an interrupt signal. The received address and message data can then be read via the I²C-bus interface.

8.7 OFF status

In the OFF status the decoder will neither activate the receiver or oscillator enable outputs, nor process any data at the data input. The crystal oscillator remains active to permit communication with the microcontroller.

In both operating states an accurate timing reference is available via the REF output. Using SPF programming the signal periodicity may be selected as; 32.768 kHz, 50 Hz, 2 Hz or 1/60 Hz.

8.8 Reset

The decoder can be reset by applying a positive pulse on input pin RST. For successful reset at power-on, a HIGH level must be present on the RST pin while the device is powering-up.

This can be applied by the microcontroller, or via a suitable RC power-on reset circuit connected to the RST input. Reset circuit details and conditions during and after a reset are described in Chapter 9.

Enhanced Pager Decoder for APOC1/POCSAG

PCD5002A

8.9 Bit rates

The PCD5002A can be configured for data rates of 512, 1200 or 2400 bits/s by SPF programming. These data rates are derived from a single 76.8 kHz oscillator frequency.

8.10 Oscillator

The oscillator circuit is designed to operate at 76.8 kHz. Typically, a tuning fork crystal will be used as a frequency source. Alternatively, an external clock signal can be applied to pin XTAL1 (amplitude = V_{DD} to V_{SS}), but a slightly higher oscillator current is consumed. A 2.2 M Ω feedback resistor connected between XTAL1 and XTAL2 is required for proper operation.

To allow easy oscillator adjustment (e.g. by a variable capacitor) a 32.768 kHz reference frequency can be selected at output REF by SPF programming.

8.11 Input data processing

Data input is binary and fully asynchronous. Input bit rates of 512, 1200 and 2400 bits/s are supported. As a programmable option, the polarity of the received data can be inverted before further processing.

The input data is noise filtered by a digital filter. Data is sampled at 16 times the data rate and averaged by majority decision.

The filtered data is used to synchronize an internal clock generator by monitoring transitions. The recovered clock phase can be adjusted in steps of $\frac{1}{8}$ or $\frac{1}{32}$ bit period per received bit.

The larger step size is used when bit synchronization has not been achieved, the smaller when a valid data sequence has been detected (e.g. preamble or sync word).

8.12 Battery saving

Current consumption is reduced by switching off internal decoder sections whenever the receiver is not enabled.

To further increase battery efficiency, reception and decoding of an address code-word is stopped as soon as the uncorrected address field differs by more than 3 bits from the enabled RICs. If the next code-word must be received again, the receiver is re-enabled thus observing the programmed establishment times t_{RXE} and t_{ROE} .

The current consumption of the complete pager can be minimized by separately activating the RF oscillator circuit (using output ROE) before activating the rest of the receiver. This is possible using the UAA2082 receiver which has external biasing for the oscillator circuit.

8.13 POCSAG synchronization strategy

In the ON status the PCD5002A synchronizes to the POCSAG data stream by the Philips ACCESS[®] algorithm. A flow diagram is shown in Fig.4. Where 'sync word' is used, this implies both the standard POCSAG sync word and any enabled User Programmable Sync Word (UPSW).

Several modes of operation can be distinguished depending on the synchronization state. Each mode uses a different method to obtain or retain data synchronization. The receiver and oscillator enable outputs (RXE and ROE respectively) are switched accordingly, with the appropriate establishment times (t_{RXON} and t_{ROON} respectively).

Before comparing received data with preamble, an enabled sync word or programmed user addresses, the appropriate error correction is applied.

Initially, after switching to the ON status, the decoder is in **switch-on** mode. Here the receiver will be enabled for a period up to 3 batches, testing for preamble and the sync word. Failure to detect preamble or the sync word will cause the device to switch to the 'carrier off' mode.

When preamble is detected it will cause the device to switch to the **preamble receive** mode, in which a sync word is searched for. The receiver will remain enabled while preamble is detected. When neither sync word nor preamble is found within a 1 batch duration the 'carrier off' mode is entered.

Upon detection of a sync word the **data receive** mode is entered. The receiver is activated only during enabled user address frames and sync word periods. When an enabled user address has been detected, the receiver will be kept enabled for message code-word reception until the call termination criteria are met.

During call reception data bytes are stored in an internal SRAM buffer, capable of storing 2 batches of message data.

Messages are transmitted contiguously, only interrupted by sync words at the beginning of each batch.

Enhanced Pager Decoder for APOC1/POCSAG

PCD5002A

When a message extends beyond the end of a batch no testing for sync takes place. Instead, a message data transfer will be initiated by an interrupt to the external controller. Data reception continues normally after a period corresponding to the sync word duration.

If any message code-word is found to be uncorrectable, the 'data fail' mode is entered and no data transfer will be attempted at the next sync word position. Instead, a test for sync word will be carried out.

In the **data fail** mode message reception continues normally for 1 batch duration. When a sync word is detected at the expected position the decoder returns to the 'data receive' mode. If the sync word again fails to appear, then batch synchronization is deemed lost. Call reception is then terminated and the 'fade recovery' mode is entered.

The **fade recovery** mode is intended to scan for sync word and preamble over an extended window (nominal position ± 8 bits). This is performed for a period of up to

15 batches, allowing recovery of synchronization from long fades in the radio signal. Detection of preamble causes switching to the 'preamble receive' mode, while sync word detection causes switching to the 'data receive' mode. When neither is found within a period of 15 batches, the radio signal is considered lost and the 'carrier off' mode is entered.

The purpose of the **carrier off** mode is to detect a valid radio transmission and synchronize to it quickly and efficiently. Because transmissions may start at random, the decoder enables the receiver for 1 code-word in every 18 code-words looking for preamble or sync word. By using a buffer containing 32 bits (n bits from the current scan, 32 - n from the previous scan) effectively every batch bit position can be tested within a continuous transmission of at least 18 batches. Detection of preamble causes the device to switch to the 'preamble receive' mode, while sync word detection causes the device to switch to the 'data receive' mode.

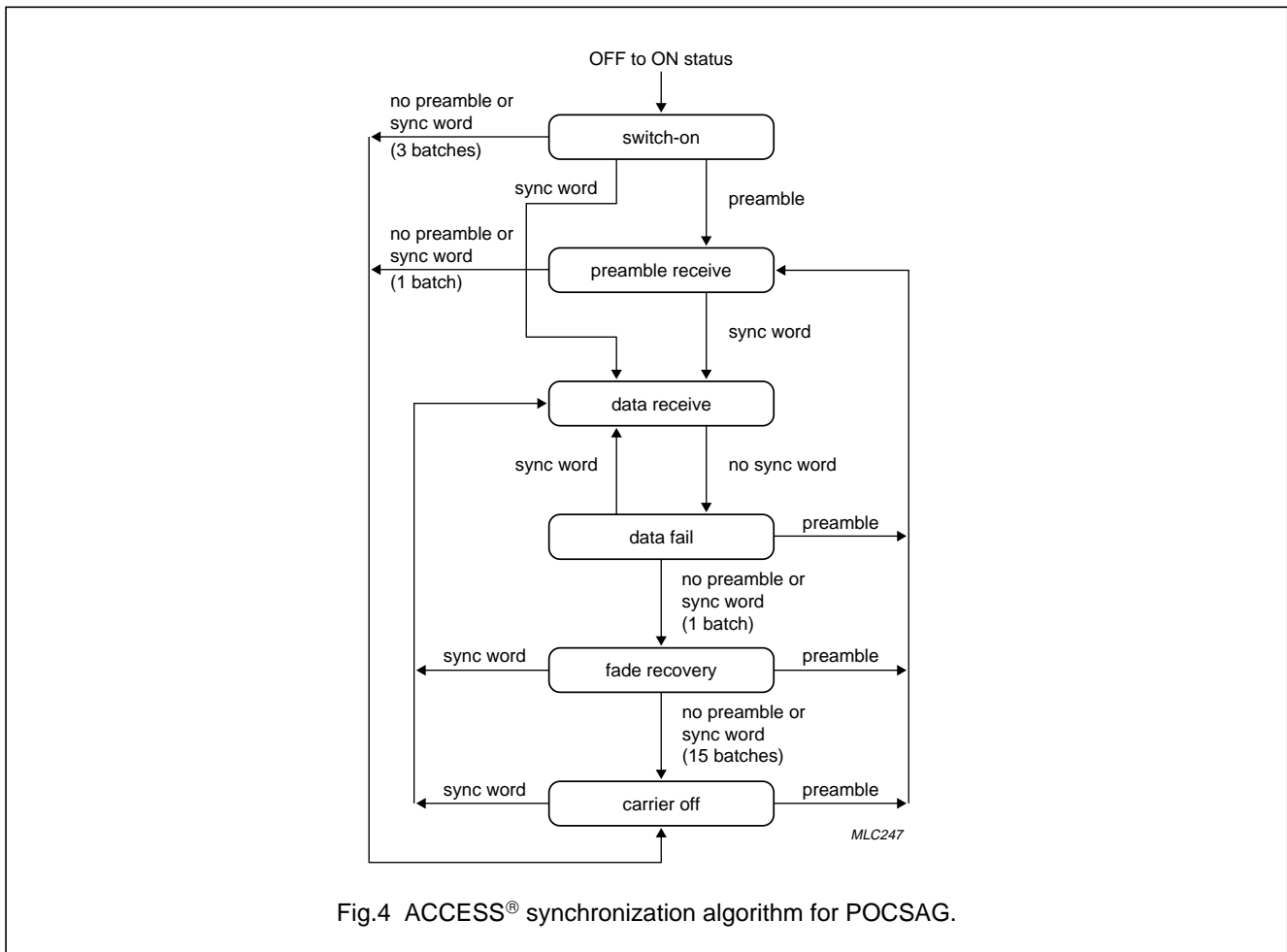

Fig.4 ACCESS® synchronization algorithm for POCSAG.

Enhanced Pager Decoder for
APOC1/POCSAG

PCD5002A

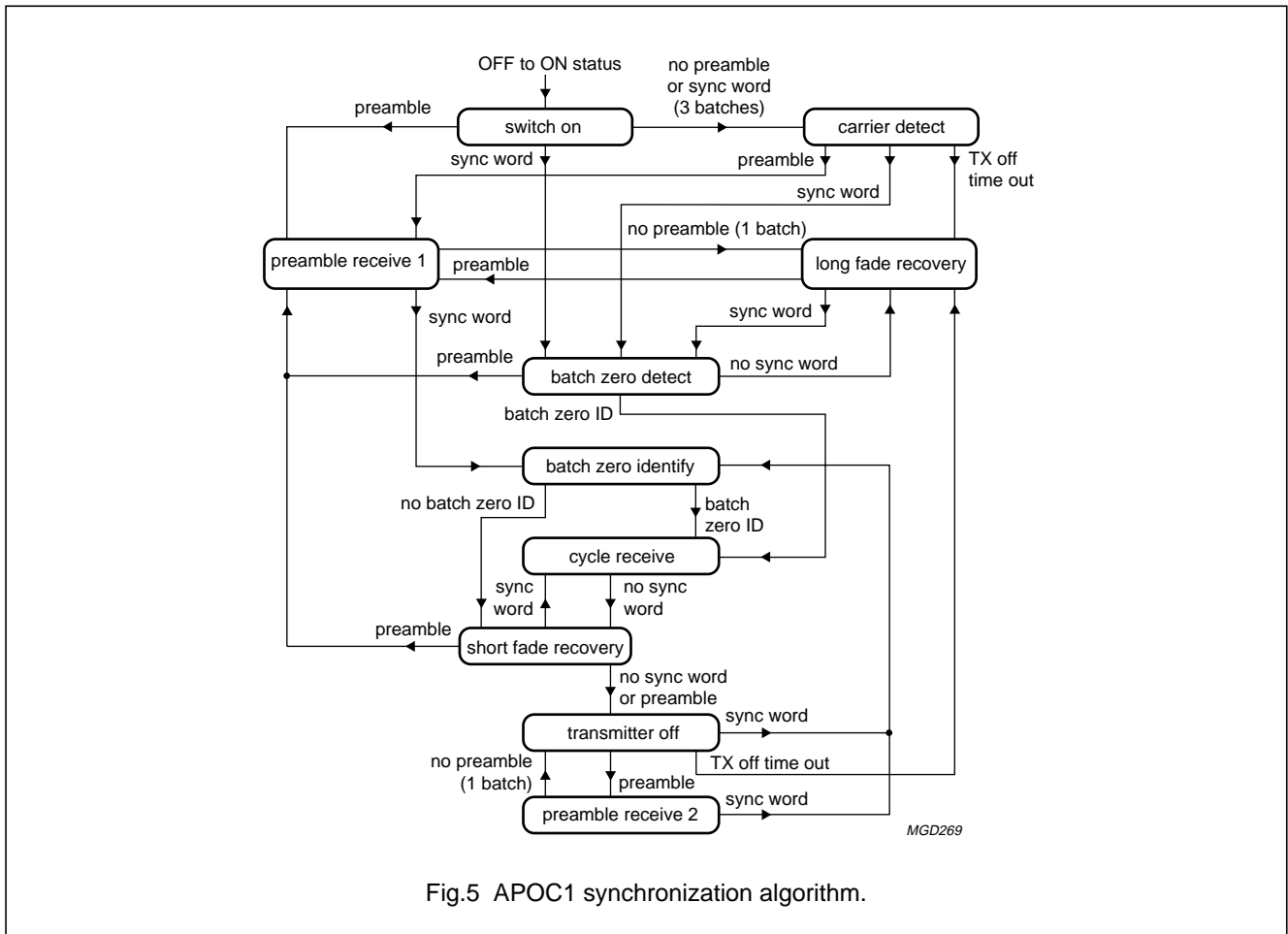

Fig.5 APOC1 synchronization algorithm.

8.14 APOC1 synchronization strategy

The synchronization strategy in APOC1 is an extended version of the ACCESS[®] scheme and is illustrated in Fig.5. The PCD5002A counts the number of batches in a transmission, starting from the first batch received after preamble. Counter overflow occurs due to the size of a cycle, as determined by SPF programming.

Initially, after switching to the ON status, the decoder will be in the **switch-on** mode. Here the receiver will be enabled for up to 3 batches, testing for preamble and sync word. Detection of preamble causes the device to switch to the 'preliminary receive' mode, while any enabled sync word enters the 'batch zero detect' mode. Failure to detect either will cause the device to switch to the 'carrier detect' mode.

In the **preliminary receive 1** mode the PCD5002A searches for a sync word, the receiver remaining enabled while preamble is detected. As soon as an enabled sync word is found the 'batch zero identify' mode is started.

If preamble is not found within one batch duration then the 'long fade recovery' mode is entered.

When in **batch zero detect** mode the PCD5002A switches on every batch to maintain synchronization and check for the batch zero identifier. Detection of the batch zero identifier activates the 'cycle receive' mode. When synchronization is lost the 'long fade recovery' mode is entered. 'preliminary receive' mode is entered when preamble is detected.

In the **batch zero identify** mode the first code-word immediately after the sync word of the first batch is compared with the programmed batch zero identifier. Failure to detect the batch zero identifier will cause the device to enter the 'short fade recovery' mode.

When this comparison is successful the function bits determine whether any broadcast message will follow. Any function bit combination other than '1,1' will cause the PCD5002A to accept message code-words until terminated by a valid address code-word.

Enhanced Pager Decoder for APOC1/POCSAG

PCD5002A

After reception of any broadcast message data the PCD5002A continues to operate in the 'cycle receive' mode.

In the **cycle receive** mode the PCD5002A enables call reception in only one programmed batch per cycle. Sync word detection takes place from 2 bits before to 2 bits after the expected sync word position of this batch. If the sync word is not detected then the position of the current sync word will be maintained and the 'short fade recovery' mode will be entered.

When a valid sync word is found user address code-word detection takes place, as in normal POCSAG code. Any following message code-words are received normally. If a message extends into a subsequent batch containing a batch zero identifier, then the batch zero identifier is detected normally and message reception will continue.

Data reception is suspended after the programmed batch until the same batch position in the next cycle. The exception being when a received call continues into the next batch.

In the **short fade recovery** mode the programmed data receive batch will continue to be checked for user address code-words. In addition the first code-word after the programmed batch is checked for sync word or preamble.

When a valid sync word is detected the 'cycle receive' mode is re-entered, while detection of preamble causes the device to switch to the 'preamble receive' mode. When neither is found then the 'transmitter off' mode is entered.

In the **transmitter off** mode a time-out is set to a pre-programmed duration. This time-out corresponds to the maximum time between subsequent transmissions (preamble to preamble).

The PCD5002A then checks the first batch of every cycle for sync word or preamble. The programmed data receive batch is ignored (unless it is batch 0).

Table 4 Synchronization window tolerance as a function of bit rate

TIME FROM LOSS OF SIGNAL	TOLERANCE		
	512 (bits/s)	1200 (bits/s)	2400 (bits/s)
≤30 s	4 bits	4 bits	4 bits
≤60 s	4 bits	4 bits	8 bits
≤120 s	4 bits	8 bits	16 bits
≤240 s	8 bits	16 bits	32 bits

Synchronization checking is performed over a window ranging from 'n' bits before to 'n' bits after the expected sync word position. The window tolerance 'n' depends on the time since the 'transmitter off' mode was entered and on the selected bit rate (see Table 4).

When a sync word is detected in this widened synchronization window the PCD5002A enters the 'batch zero identify' mode. Time-out expiry before a sync word has been detected causes the device to switch to the 'long fade recovery' mode.

Detection of preamble in the 'transmitter off' mode initiates the **preamble receive 2** mode. Operation in this mode is identical to 'preamble receive mode'. Failure to detect preamble for one batch period will cause the device to switch back to the 'transmitter off' mode. This prevents inadvertent loss of cycle synchronization due to spurious signals resembling preamble.

The **carrier detect** mode is identical to the 'carrier off' mode in standard POCSAG operation. Upon first entry the transmitter off time-out is started. The receiver is enabled to receive one code-word in every 18 code-words to check for sync word and preamble. This check is performed on the last available 32 bits for every received bit.

The 'preamble receive' mode is entered if preamble is detected. If a valid sync word is found the 'batch zero detect' mode is entered. If neither has been detected and the time-out expires, then the 'long fade recovery' mode is entered.

The **long fade recovery** mode is intended to quickly regain synchronization in fading conditions (not caused by the transmitter switching off between transmissions) or when having been out of range, while maintaining acceptable battery economy.

Initially, the receiver is switched off until one cycle duration after the last enabling in the 'transmitter off' mode. The receiver is then enabled for a 2 code-word period in which each contiguous group of 32 bits is tested for **any decodable** POCSAG code-word (including sync word) and preamble. Single-bit error correction is applied.

If a code-word is detected, the receiver enable period is extended by another code-word duration and the above test is repeated. This process continues while valid code-words are received.

Enhanced Pager Decoder for APOC1/POCSAG

PCD5002A

Detection of preamble will cause the device to switch to the 'preamble receive' mode, while sync word detection will cause the device to switch to the 'batch zero detect' mode. When neither is detected during the 2 code-word window or any following 32-bit group, the receiver will be disabled.

If valid code-words are detected but no sync word or preamble is detected over a period of 18 code-words, the receiver is also disabled.

Data sampling, as previously described, is repeated one cycle duration after the moment the receiver was last activated.

8.15 Call termination

Call reception is terminated:

- Upon reception of any address code-word (including idle code-word but excluding the batch zero identifier in APOC1 operation) requiring no more than single bit error correction
- Upon reception of a correctable address code-word (error type other than '111'; see Table 11) that matches an enabled RIC
- When a forced call termination command is received from an external controller.
- In 'data fail' mode, when a sync word is not detected at the expected batch position.

The last method permits an external controller to stop call reception, depending on the number and type of errors which occurred in a call. After a forced call termination the decoder will enter the 'data fail' mode.

The type of error correction as well as the call termination conditions are indicated by status bits in the message data output.

In the event of the terminating code-word matching an enabled RIC, a concatenated call will be started with the call header replacing the terminator of the previous call.

Following call termination, transfer of the data received since the previous sync word period is initiated by an interrupt to the external controller.

8.16 Enhanced call termination

The PCD5002A provides an enhanced mode of call termination which is enabled by setting SPF byte 3, bit D7. When enabled, the following call termination conditions applies, in addition to those listed in Section 8.15.

- Reception of two consecutive code-words (excluding sync word), each of which are either uncorrectable or an address code-word with more than one bit in error.

8.17 Call data output format

POCSAG call information is stored in the decoder SRAM in blocks of 3 bytes per code-word. Each stored call consists of a call header, followed by message data blocks and a call terminator. In the event of concatenated messages the call terminator is replaced with the call header of the next message. An alert-only call only has a call header and a call terminator.

The formats of a call header, a message data block and a call terminator are shown in Tables 5, 7 and 9.

A **Call Header** contains information on the last sync word received, the RIC which began call reception and the type of error correction performed on the address code-word.

A **Message Data** block contains the data bits from a message code-word plus the type of error correction performed. No deformatting is performed on the data bits: numeric data appear as 4-bit groups per digit, alphanumeric data has a 7-bit ASCII representation.

The **Call Terminator** contains information on the last sync word received, information on the way the call was terminated (forced call termination command, loss of sync word in 'data fail' mode) and the type of error correction performed on the terminating code-word.

Enhanced Pager Decoder for APOC1/POCSAG

PCD5002A

Table 5 Call header format

BYTE NUMBER	BIT 7 (MSB)	BIT 6	BIT 5	BIT 4	BIT 3	BIT 2	BIT 1	BIT 0 (LSB)
1	0	S3	S2	S1	R3	R2	R1	DF
2	0	S3	S2	S1	R3	R2	R1	0
3	X	X	F0	F1	E3	E2	E1	0

Table 6 Call header bit identification

BITS (MSB TO LSB)	IDENTIFICATION
S3 to S1	identifier number of sync word for current batch (7 = standard POCSAG)
R3 to R1	identifier number of user address (RIC)
DF	data fail mode indication (1 = data fail mode); note 1
F0 and F1	function bits of received address code-word (bits 20 and 21)
E3 to E1	detected error type; see Table 11; E3 = 0 in a concatenated call header

Note

1. The DF bit in the call header is set:
 - a) When the sync word of the batch in which the (beginning of the) call was received, did not match the standard POCSAG or a user-programmed sync word. The sync word identifier (bits S3 to S1) will then be made 0.
 - b) When any code-word of a previous call received in the same batch was uncorrectable.

Table 7 Message data format

BYTE NUMBER	BIT 7 (MSB)	BIT 6	BIT 5	BIT 4	BIT 3	BIT 2	BIT 1	BIT 0 (LSB)
1	M2	M3	M4	M5	M6	M7	M8	M9
2	M10	M11	M12	M13	M14	M15	M16	M17
3	M18	M19	M20	M21	E3	E2	E1	M1

Table 8 Message data bit identification

BITS (MSB TO LSB)	IDENTIFICATION
M2 to M21	message code-word data bits
E3 to E1	detected error type; see Table 11
M1	message code-word flag

Table 9 Call terminator format

BYTE NUMBER	BIT 7 (MSB)	BIT 6	BIT 5	BIT 4	BIT 3	BIT 2	BIT 1	BIT 0 (LSB)
1	FT	S3	S2	S1	0	0	0	DF
2	FT	S3	S2	S1	0	0	0	X
3	X	X	X	X	E3	E2	E1	0

Enhanced Pager Decoder for APOC1/POCSAG

PCD5002A

Table 10 Call terminator bit identification

BITS (MSB TO LSB)	IDENTIFICATION
FT	forced call termination (1 = yes)
S3 to S1	identifier number of last sync word
DF	data fail mode indication (1 = data fail mode); note 1
E3 to E1	detected error type; see Table 11; E3 = 0 in a call terminator

Note

- The DF bit in the call terminator is set:
 - When any call data code-word in the terminating batch was uncorrectable, while in 'data receive' mode.
 - When the sync word at the start of the terminating batch did not match the standard POCSAG or a user-programmed sync word, while in 'data fail' mode.

Table 11 Error type identification (note 1)

E3	E2	E1	ERROR TYPE	NUMBER OF ERRORS
0	0	0	no errors; correct code-word	0
0	0	1	parity bit in error	1
0	1	0	single bit error	1 + parity
0	1	1	single bit error and parity error	1
1	0	0	not used	–
1	0	1	4-bit burst error and parity error	3 (e.g. 1101)
1	1	0	2-bit random error	2
1	1	1	uncorrectable code-word	3 or more

Note

- POCSAG code allows a maximum of three bit errors to be detected per code-word.

8.18 Error type indication

Table 11 shows how the different types of detected errors are encoded in the call data output format.

8.19 Data transfer

Data transfer is initiated either during sync word periods or as soon as the receiver is disabled after call termination. If the SRAM buffer is full, data transfer is initiated immediately during the next code-word.

When the PCD5002A is ready to transfer received call data an external interrupt will be generated via output INT. Any message data can be read by accessing the RAM output register via the I²C-bus interface. Bytes will be output starting from the position indicated by the RAM read pointer.

Call termination can occur on reception of an address code-word (or even a message code-word if in Enhanced Call Termination Mode) or when a sync word is not

detected while in the 'Data Fail' mode ('Short Fade Recovery' in APOC1).

8.20 Continuous data decoding

Apart from transmissions in the POCSAG or APOC1 format, the PCD5002A is also capable of decoding continuous transmissions with the same code-word structure. Any User-Programmable Sync Word (UPSW) may be designated to enable continuous data decoding.

When a Continuous Data Decoding (CDD) sync word is detected at any sync word position, the receiver remains enabled from then on. Status bits D1 and D0 show the CDD mode to be active.

All code-words are decoded and their data fields are stored in SRAM. The usual error information is appended. No distinction is made between address and message code-words: code-word bit 0 is treated as a data bit and is stored in bit M1 of the 3-byte output format.

Enhanced Pager Decoder for APOC1/POCSAG

PCD5002A

Code-words received at the expected sync word positions (POCSAG batch size) are matched against standard POCSAG sync word, all enabled UPSWs and preamble.

Data output to an external controller is initiated by an interrupt at the next sync word position, after reception of 16 code-words.

The call header preceding the data has a different structure from normal POCSAG or APOC1 data. The data header format is shown in Table 12.

Continuous data decoding continues until one of the following conditions occur:

- The decoder is switched to the OFF state
- A Forced Call Termination (FCT) command is received via the I²C-bus
- Preamble is detected at the sync word position
- Standard POCSAG sync word or an enabled non-CDD sync word is detected.

Only a forced call termination command will be indicated in the SRAM data by a call terminator. In the other events continuous data decoding will stop without notification.

Upon forced termination the 'fade recovery' mode is entered. Detection of preamble causes the device to switch to the 'preamble receive' mode. Detection of a standard sync word or any enabled non-continuous UPSW will cause the device to switch to the 'data receive' mode.

Continuous data decoding will continue in the next batch if any enabled CDD sync word is detected or no enabled sync word is detected. It should be noted that the enhanced call termination is ignored in CCD mode.

8.21 Receiver and oscillator control

A paging receiver and an RF oscillator circuit can be controlled independently via enable outputs RXE and ROE respectively. Their operating periods are optimized according to the synchronization mode of the decoder. Each enable signal has its own programmable establishment time (see Table 14).

Table 12 Continuous data header format

BYTE NUMBER	BIT 7 (MSB)	BIT 6	BIT 5	BIT 4	BIT 3	BIT 2	BIT 1	BIT 0 (LSB)
1	0	X	X	X	C3	C2	C1	0
2	0	C3	C2	C1	C3	C2	C1	0
3	X	X	F0	F1	E3	E2	E1	0

Table 13 Data header bit identification

BITS (MSB TO LSB)	IDENTIFICATION
C3 to C1	identifier number of continuous data decoding sync word
F0 and F1	function bits of received address code-word (bits 20 and 21)
E3 to E1	detected error type (see Table 11); E3 = 0 in a concatenated call header

Table 14 Receiver and oscillator establishment times (note 1)

CONTROL OUTPUT	ESTABLISHMENT TIME				UNIT
RXE	5	10	15	30	ms
ROE	20	30	40	50	ms

Note

1. The exact values may differ slightly from the above values, depending on the bit rate (see Table 25).

Enhanced Pager Decoder for APOC1/POCSAG

PCD5002A

8.22 Demodulator quick charge

Two modes of operation are available that determine the period when the DQC output is set

The operating mode is selected by EEPROM programming of SPF byte 03, bit D5:

- **Mode 0 (D5 = 0):** DQC is active HIGH during the receiver establishment time (t_{RXE}) in all ACCESS and APOC1 modes except data receive and data fail (cycle receive and short fade recovery in APOC1). During switch-on, DQC is active for 1 code-word duration.
- **Mode 1 (D5 = 1):** DQC is active during sync word detection in all ACCESS and APOC1 modes. During switch-on and preamble receive modes, DQC is active continuously.

The timing of DQC is as follows (see Fig.6):

- **Mode 0:** Set along with RXE output (time t_{RXE} before the first code-word is expected); cleared during the second bit of the code-word following t_{RXE}
- **Mode 1:** Set during the second bit of the sync word; cleared after the last bit of the sync word.

Note: During switch-on, t_{RXE} is not used: RXE and DQC are switched on immediately.

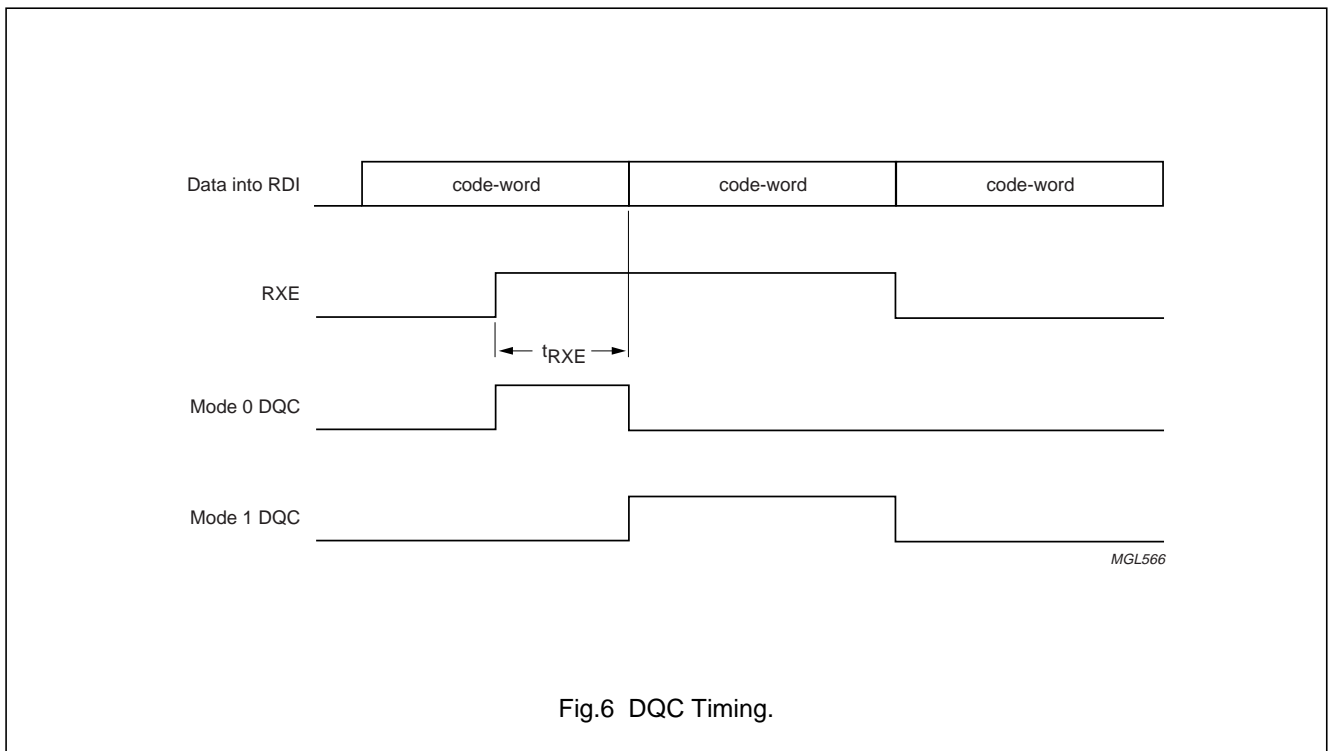

Fig.6 DQC Timing.

Enhanced Pager Decoder for APOC1/POCSAG

PCD5002A

8.23 External receiver control and monitoring

An external controller may enable the receiver control outputs continuously via an I²C-bus command, overruling the normal enable pattern. Data reception continues normally. This mode can be exited by means of a reset or an I²C-bus command.

External monitoring of the receiver control output RXE is possible via bit D6 in the status register, when enabled via the control register (D2 = 1). Each change of state of output RXE will generate an external interrupt at output INT.

8.24 Battery condition input

A logic signal from an external sense circuit, signalling battery condition, can be applied to the BAT input. This input is sampled each time the receiver is disabled (RXE ↓ 0).

When enabled via the control register (D2 = 0), the condition of input BAT is reflected in bit D6 of the status register. Each change of state of bit D6 causes an external interrupt at output INT.

When using the UAA2080 pager receiver a battery-low condition corresponds to a logic HIGH level. With a different sense circuit the reverse polarity can be used as well, because every change of state is signalled to an external controller.

After a reset the initial condition of the battery-low indicator in the status register is zero.

8.25 Synthesizer control

Control of an external frequency synthesizer is possible via a dedicated 3-line serial interface (outputs ZSD, ZSC and ZLE). This interface is common to a number of available synthesizers. The synthesizer is enabled using the oscillator enable output ROE.

The frequency parameters must be programmed in EEPROM. Two blocks of maximum 24 bits each can be stored. Any unused bits must be programmed at the beginning of a block: only the last bits are used by the synthesizer.

When the function is selected by SPF programming (SPF byte 1, bit D6), data is transferred to the synthesizer each time the PCD5002A is switched from the OFF to the ON status. Transfer takes place serially in two blocks, starting with bit 0 (MSB) of block 1 (see Table 28).

Data bits on ZSD change on the falling edges of ZSC. After clocking all bits into the synthesizer, a latch enable pulse copies the data to the internal divider registers. A timing diagram is illustrated in Fig.7.

The data output timing is synchronous, but has a pause in the bitstream of each block. This pause occurs in the 13th bit while ZSC is LOW. The nominal pause duration t_p depends on the programmed bit rate for data reception and is shown in Table 15. The total duration of the 13th bit is given by $t_{ZCL} + t_p$.

A similar pause occurs between the first and the second data block. The delay between the first latch enable pulse and the second data block is given by $t_{ZDL2} + t_p$. The complete start-up timing of the synthesizer interface is illustrated in Fig.14.

Table 15 Synthesizer programming pause

BIT RATE (bits/s)	t_p (CLOCKS)	t_p (μ s)
512	119	1549
1200	33	430
2400	1	13

8.26 Serial microcontroller interface

The PCD5002A has an I²C-bus serial microcontroller interface capable of operating at 400 kbits/s. The PCD5002A is a slave transceiver with a 7-bit I²C-bus address 39 (bits A6 to A0 = 0100111).

Data transmission requires 2 lines: SDA (data) and SCL (clock), each with an external pull-up resistor. The clock signal (SCL) for any data transmission must be generated by the external controlling device.

A transmission is initiated by a START condition (S: SCL = 1, SDA = ↓) and terminated by a STOP condition (P: SCL = 1, SDA = ↑).

Data bits must be stable when SCL is HIGH. If there are multiple transmissions, the STOP condition can be replaced with a new START condition.

Data is transferred on a byte basis, starting with a device address and a read/write indicator. Each transmitted byte must be followed by an acknowledge bit A (active LOW). If a receiving device is not ready to accept the next complete byte, it can force a bus wait state by holding SCL LOW.

The general I²C-bus transmission format is illustrated in Fig.6. Formats for master/slave communication are illustrated in Fig.9.

Enhanced Pager Decoder for APOC1/POCSAG

PCD5002A

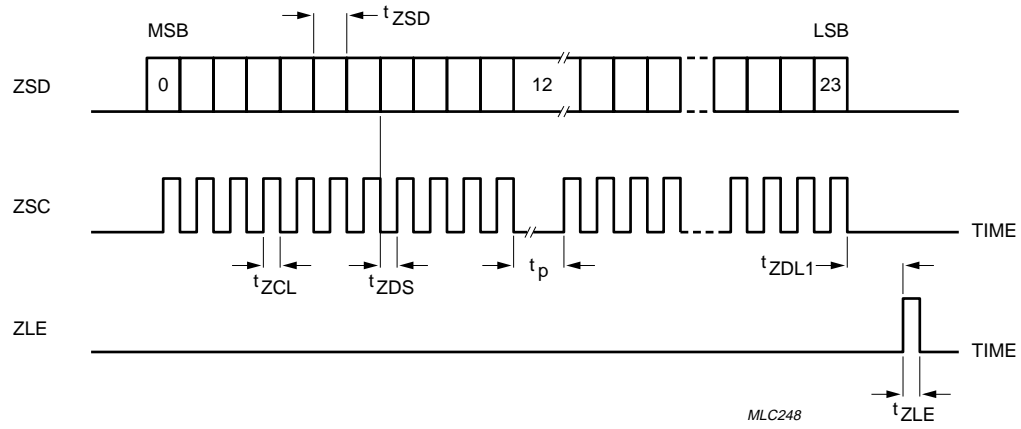

Fig.7 Synthesizer interface timing.

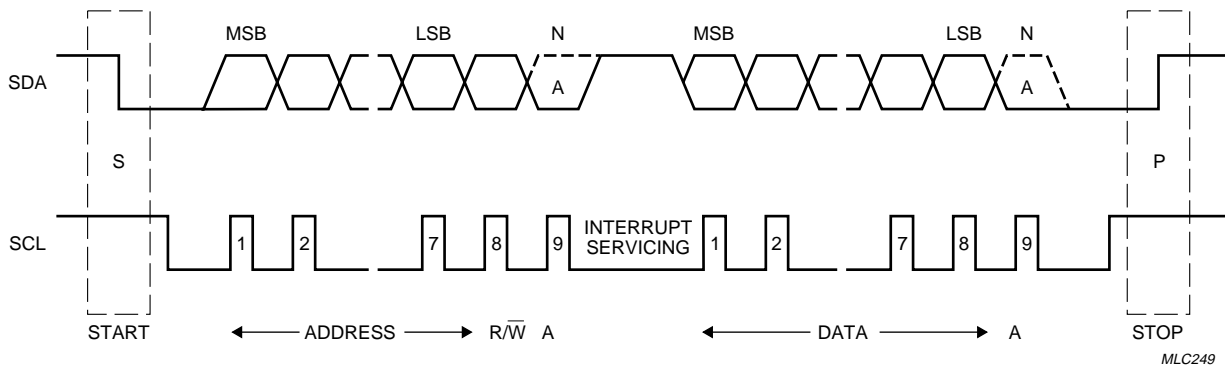
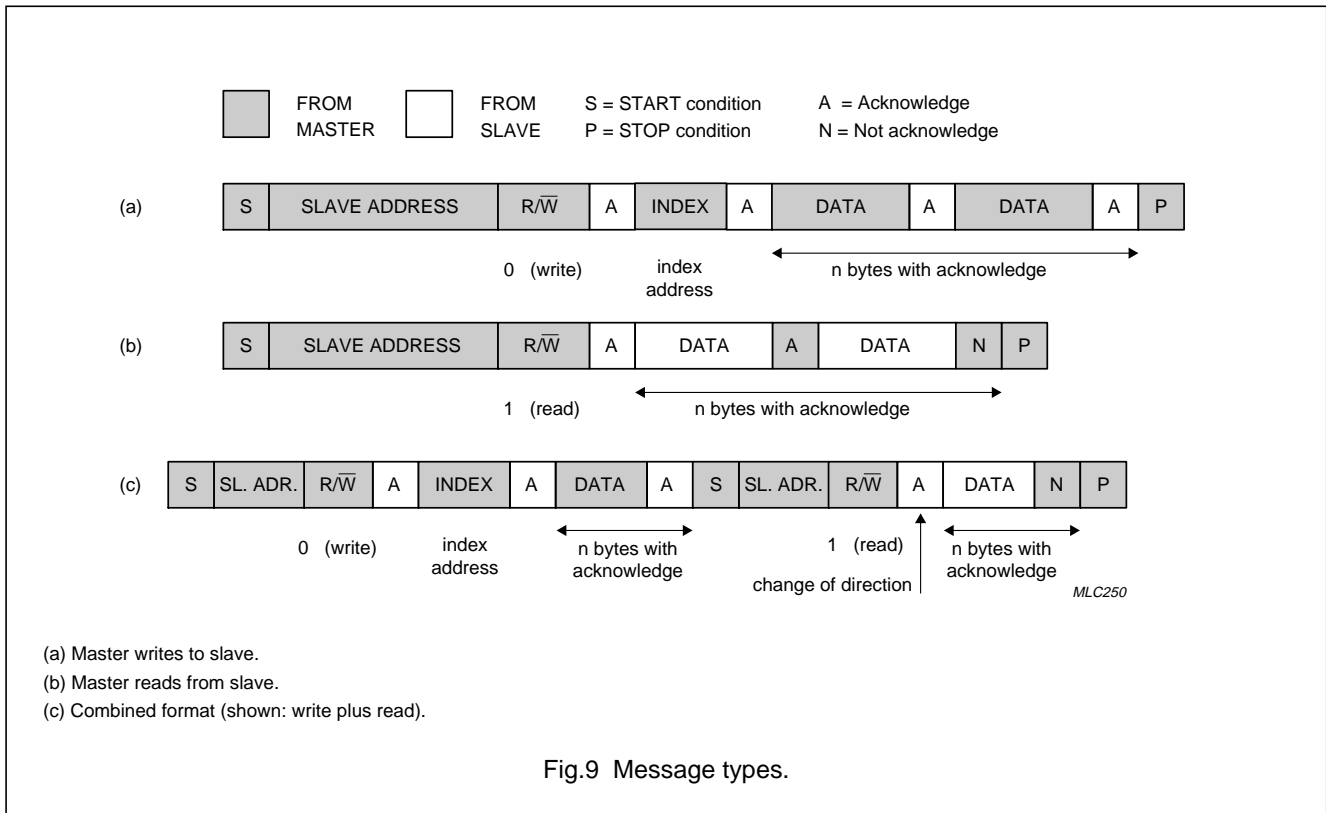

Fig.8 I²C-bus message format.

Enhanced Pager Decoder for
APOC1/POCSAG

PCD5002A



8.27 Decoder I²C-bus access

All internal access to the PCD5002A takes place via the I²C-bus interface. For this purpose the internal registers, SRAM and EEPROM have been memory mapped and are accessed via an **index register**. Table 16 shows the index addresses of all internal blocks.

Registers are addressed directly, while RAM and EEPROM are addressed indirectly via address pointers and I/O registers.

Remark: The EEPROM memory map is non-contiguous and is organized as a matrix. The EEPROM address pointer contains both row and column indicators.

Data written to read-only bits will be ignored. Values read from write-only bits are undefined and must be ignored.

Each I²C-bus write message to the PCD5002A must start with its slave address, followed by the index address of the memory element to be accessed. An I²C-bus read message uses the last written index address as a data source. The different I²C-bus message types are shown in Fig.9.

As a slave the PCD5002A cannot initiate bus transfers by itself. To prevent an external controller from having to monitor the operating status of the decoder, all important events generate an external interrupt on output INT.

Enhanced Pager Decoder for APOC1/POCSAG

PCD5002A

Table 16 Index register

ADDRESS ⁽¹⁾	REGISTER FUNCTION	ACCESS
00H	status	R
00H	control	W
01H	real-time clock: seconds	R/ \overline{W}
02H	real-time clock: $\frac{1}{100}$ second	R/ \overline{W}
03H	alert cadence	W
04H	alert set-up	W
05H	periodic interrupt modulus	W
05H	periodic interrupt counter	R
06H	RAM write address pointer	R
07H	EEPROM address pointer	R/ \overline{W}
08H	RAM read address pointer	R/ \overline{W}
09H	RAM data output	R
0AH	EEPROM data input/output	R/ \overline{W}
0BH to 0FH	unused	note 2

Notes

1. The index register only uses the least significant nibble, the upper 4 bits are ignored.
2. Writing to registers 0B to 0F has no effect, reading produces meaningless data.

8.28 External interrupt

The PCD5002A can signal events to an external controller via an interrupt signal at output INT. The interrupt polarity is programmable via SPF programming. The interrupt source is shown in the status register.

Interrupts are generated by the following events (more than one event is possible):

- Call data available for output (bit D2)
- SRAM pointers becoming equal (bit D3)
- Expiry of periodic time-out (bit D7)
- Expiry of alert time-out (bit D4)
- Change of state in out-of-range indicator (bit D5)
- Change of state in battery-low indicator or in receiver control output RXE (bit D6).

Immediate interrupts are generated by status bits D3, D4, D6 (RXE monitoring) and D7. Bits D2, D5 and D6 (BAT monitoring) generate interrupts as soon as the receiver is disabled (RXE = 0).

When call data is available (D2 = 1) but the receiver remains switched on, an interrupt is generated at the next sync word position, if data fail mode (short fade recovery mode in APOC1) is not active.

The interrupt output INT is reset after completion of a status read operation.

8.29 Interrupt masking

In the PCD5002A certain interrupts can be suppressed by masking via the control register. The following interrupts can be masked:

- **Out-of-Range (status bit D5):** change of state interrupt, masked by setting control register bit D5
- **BAT/RXE monitoring (status bit D6):** change of state interrupt (source selected by control register bit D2), masked by setting control register bit D6
- **Periodic Timer (status bit D7):** timer overflow interrupt, masked by setting control register bit D7.

Although no interrupts are generated by these conditions when masked via the control register, the corresponding status bits are updated normally and available via the status register. At reset the control register is cleared, causing all interrupts to be enabled.

Enhanced Pager Decoder for APOC1/POCSAG

PCD5002A

8.30 Status/control register

The status/control register consists of two independent registers, one for reading (status) and one for writing (control).

The status register shows the current operating condition of the decoder and the cause(s) of an external interrupt.

The control register activates/deactivates certain functions. Tables 17 and 18 show the bit allocations of both registers.

All status bits will be reset after a status read operation except for the out-of-range, battery-low and receiver enable indicator bits (see note 1 to Table 17).

Table 17 Status register (00H; read)

BIT ⁽¹⁾	VALUE	DESCRIPTION
D1 and D0	0 0	no new call data
	0 1	new call received (POCSAG or APOC1)
	1 0	continuous decoding data available
	1 1	batch zero data available (APOC1)
D3 and D2	0 0	no data to be read (default after reset)
	0 1	RAM read/write pointers different; data to be read
	1 0	RAM read/write pointers equal; no more data to read
	1 1	RAM buffer full or overflow
D4	1	alert time-out expired
D5	1	out-of-range
D6	1	BAT input HIGH or RXE output active (selected by control bit D2)
D7	1	periodic timer interrupt

Note

1. After a status read operation bits D3, D4 and D7 are always reset, bits D1 and D0 only when no second call is pending. D2 is reset when the RAM is empty (read and write pointers equal).

Table 18 Control register (00H; write)

BIT (MSB: D7)	VALUE	DESCRIPTION
D0	1	forced call termination (automatically reset after termination)
D1	1	EEPROM programming enable
D2	0	BAT input selected for monitoring (status bit D6)
	1	RXE output selected for monitoring (status bit D6)
D3	1	receiver continuously enabled (RXE = 1 and ROE = 1)
D4	0	decoder in OFF status (while DON = 0)
	1	decoder in ON status
D5	1	out-of-range interrupt masked
D6	1	BAT/RXE monitor interrupt masked
D7	1	Periodic Timer interrupt masked

Enhanced Pager Decoder for APOC1/POCSAG

PCD5002A

8.31 Pending interrupts

A secondary status register is used for storing status bits of pending interrupts. This occurs:

- When a new call is received while the previous one was not yet acknowledged by reading the status register
- When an interrupt occurs during a status read operation.

After completion of the status read the primary register is loaded with the contents of the secondary register, which is then reset. An immediate interrupt is then generated, output INT becoming active 1 decoder clock cycle after it was reset following the status read.

Remark: In the event of multiple pending calls, only the status bits of the last call are retained.

8.32 Out-of-range indication

The out-of-range condition occurs when entering the 'fade recovery' or 'carrier off' mode in POCSAG, or 'transmitter off' or 'carrier detect' mode in APOC1. This condition is reflected in bit D5 of the status register. The out-of-range condition is reset when either preamble or a valid sync word is detected.

The out-of-range bit (D5) in the status register is updated each time the receiver is disabled (RXE ↓ 0). Every change of state in bit D5 generates an interrupt.

8.33 Real-time clock

The PCD5002A provides a periodic reference pulse at output REF. The frequency of this signal can be selected by SPF programming:

- 32768 Hz
- 50 Hz (square wave)
- 2 Hz
- $\frac{1}{60}$ Hz.

The 32768 Hz signal does not have a fixed period, it consists of 32 pulses distributed over 75 main oscillator cycles at 76.8 kHz. The timing is illustrated in Fig.16.

When programmed for $\frac{1}{60}$ Hz (1 pulse per minute) the pulse at output REF is held off while the receiver is enabled.

Except for the 50 Hz frequency the pulse width t_{RFP} is equal to one decoder clock period.

The real-time clock counter runs continuously irrespective of the operating condition of the PCD5002A. It contains a **seconds register** (maximum 59) and a **$\frac{1}{100}$ second register** (maximum 99), which can be read from or written

to via the I²C-bus. The bit allocation of both registers is shown in Tables 19 and 20.

Table 19 Real-time clock; seconds register (01H; read/write)

BIT (MSB D7)	VALUE	DESCRIPTION
D0	–	1 s
D1	–	2 s
D2	–	4 s
D3	–	8 s
D4	–	16 s
D5	–	32 s
D6	X	not used: ignored when written; undetermined when read
D7	X	not used: ignored when written; undetermined when read

Table 20 Real-time clock; $\frac{1}{100}$ second register (02H; read/write)

BIT (MSB D7)	VALUE	DESCRIPTION
D0	–	0.01 s
D1	–	0.02 s
D2	–	0.04 s
D3	–	0.08 s
D4	–	0.16 s
D5	–	0.32 s
D6	–	0.64 s
D7	X	not used: ignored when written; undetermined when read

8.34 Periodic interrupt

A periodic interrupt can be realised with the periodic interrupt counter. This 8-bit counter is incremented every $\frac{1}{100}$ s and produces an interrupt when it reaches the value stored in the periodic interrupt modulus register. The counter register is then reset and counting continues.

Operation is started by writing a non-zero value to the modulus register. Writing a zero will stop interrupt generation immediately and will halt the periodic interrupt counter after 2.55 s.

The modulus register is write-only, the counter register is read only. Both registers have the same index address (05H).

Enhanced Pager Decoder for APOC1/POCSAG

PCD5002A

8.35 Received call delay

Call reception (detection of an enabled RIC) causes both the periodic interrupt modulus and the counter register to be reset.

Since the periodic interrupt counter runs for another 2.55 s after a reset, the received call delay (in $\frac{1}{100}$ s units) can be determined by reading the counter register.

Table 21 Alert set-up register (04H; write)

BIT (MSB D7)	VALUE	DESCRIPTION
D0	0	call alert via cadence register
	1	POCSAG call alert (pattern selected by D7 and D6)
D1	0	LOW level acoustic alert (ATL), pulsed vibrator alert (25 Hz)
	1	HIGH level acoustic alert (ATL + ATH), continuous vibrator alert
D2	0	normal alerts (acoustic and LED)
	1	warbled alerts: 16 Hz (LED: on/off, ATL/ATH: alternate f_{AWH} , f_{AWL})
D3	1	acoustic alerts enable (ATL, ATH)
D4	1	vibrator alert enabled (VIB)
D5	1	LED alert enabled (LED)
D7 and D6 ⁽¹⁾	0 0	POCSAG alert pattern FC = 00; see Fig.10 (a)
	0 1	POCSAG alert pattern FC = 01; see Fig.10 (b)
	1 0	POCSAG alert pattern FC = 10; see Fig.10 (c)
	1 1	POCSAG alert pattern FC = 11; see Fig.10 (d)

Note

- Bits D7 and D6 correspond to function bits 20 and 21 respectively in the address code-word, which designate the POCSAG call type as shown in Table 1.

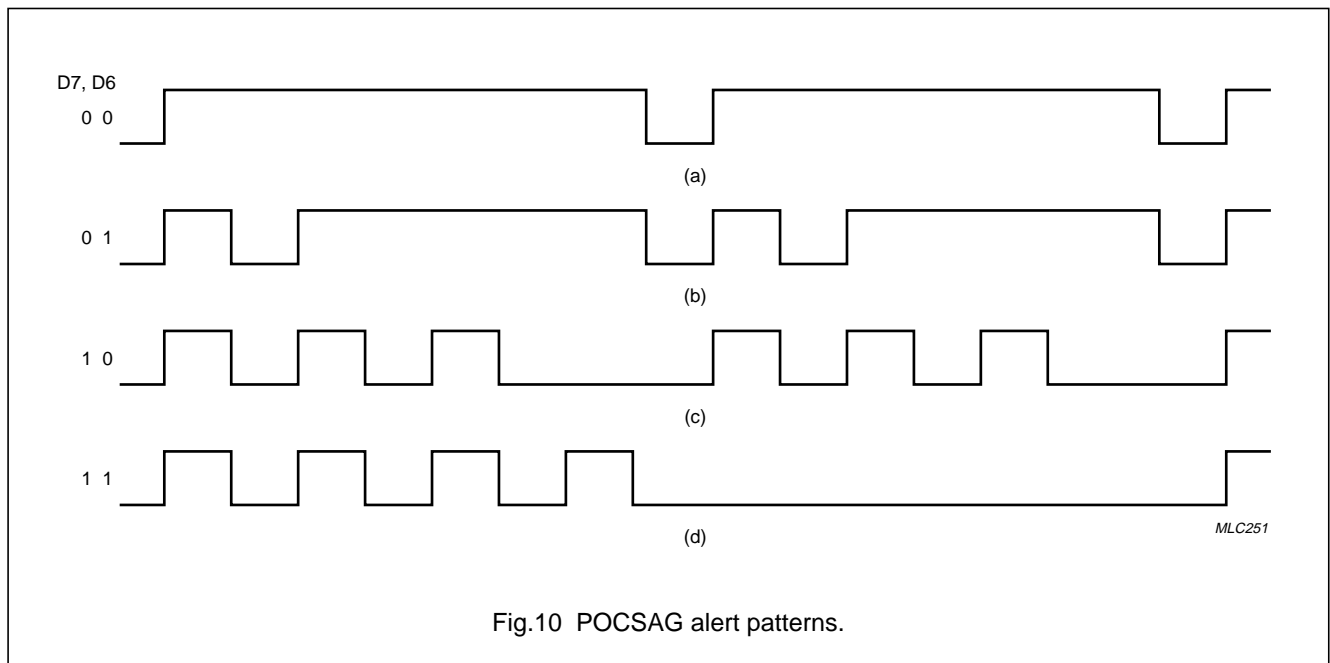

Enhanced Pager Decoder for APOC1/POCSAG

PCD5002A

8.36 Alert generation

The PCD5002A is capable of controlling 3 different alert transducers, acoustic beeper (high and low level), LED and vibrator motor. The associated outputs are ATH/ATL, LED and VIB respectively. ATL is an open-drain output capable of directly driving an acoustic alerter via a resistor. The other outputs require external transistors.

Each alert output can be individually enabled via the alert set-up register. Alert level and warble can be separately selected. The alert pattern can either be standard POCSAG or determined via the alert cadence register. Direct alert control is possible via input ALC.

The alert set-up register is shown in Table 21.

Standard POCSAG alerts can be selected by setting bit D0 in the alert set-up register, bits D6 and D7 determining the alert pattern used.

8.37 Alert cadence register (03H; write)

When not programmed for POCSAG alerts (alert set-up register bit D0 = 0), the 8-bit alert cadence register determines the alert pattern. Each bit represents a 62.5 ms time slot, a logic 1 activating the enabled alert transducers. The bit pattern is rotated with the MSB (bit D7) being output first and the LSB (bit D0) last.

When the last time slot (bit D0) is initiated an interrupt is generated to allow loading of a new pattern. When the pattern is not changed it will be repeated. Writing a zero to the alert cadence register will halt alert generation within 62.5 ms.

8.38 Acoustic alert

Acoustic alerts are generated via outputs ATL and ATH. For LOW level alerts only ATL is active, while for HIGH level alerts ATH is also active. ATL is driven in counter phase with ATH.

The alert level is controlled by bit D1 in the alert set-up register.

When D1 is reset, for standard POCSAG alerts (D0 = 1) a LOW level acoustic alert is generated during the first 4 s (ATL), followed by 12 s at HIGH level (ATL + ATH). When D1 is set, the full 16 s are at HIGH level. An interrupt is generated after the full alert time has elapsed (indicated by bit D4 in the status register).

When using the alert cadence register, D1 would normally be updated by external control when the alert time-out interrupt occurs at the start of the 8th cadence time slot.

Since D1 acts immediately on the alert level, it is advisable to reset the last bit of the previous pattern to prevent unwanted audible level changes.

8.39 Vibrator alert

The vibrator output (VIB) is activated continuously during a standard POCSAG alert or whenever the alert cadence register is non-zero.

Two alert levels are supported, LOW level (25 Hz square wave) and HIGH level (continuous). The vibrator level is controlled by bit D1 in the alert set-up register.

8.40 LED alert

The LED output pattern corresponds either to the selected POCSAG alert or to the contents of the alert cadence register. No equivalent exists for HIGH/LOW level alerts.

8.41 Warbled alert

When enabled, by setting bit D2 in the alert set-up register, the signals on outputs ATL, ATH and LED are warbled with a 16 Hz modulation frequency. Output LED is switched on and off at the modulation rate, while outputs ATL and ATH switch between f_{AWH} and f_{AWL} alerter frequencies.

8.42 Direct alert control

A direct alert control input (ALC) is available for generating user alarm signals (e.g. battery-low warning). A HIGH level on input ALC activates all enabled alert outputs, overruling any ongoing alert patterns.

8.43 Alert priority

Generation of a standard POCSAG alert (D0 = 1) overrides any alert pattern in the alert cadence register. After completion of the standard alert, the original cadence is restarted from its last position. The alert set-up register will now contain the settings for the standard alert.

The highest priority has been assigned to the alert control input (ALC). All enabled alert outputs will be activated while ALC is set. Outputs are activated/deactivated in synchronism with the decoder clock. Activation requires an extra delay of 1 clock when no alerts are being generated.

When input ALC is reset, acoustic alerting does not cease until the current output frequency cycle has been completed.

Enhanced Pager Decoder for
APOC1/POCSAG

PCD5002A

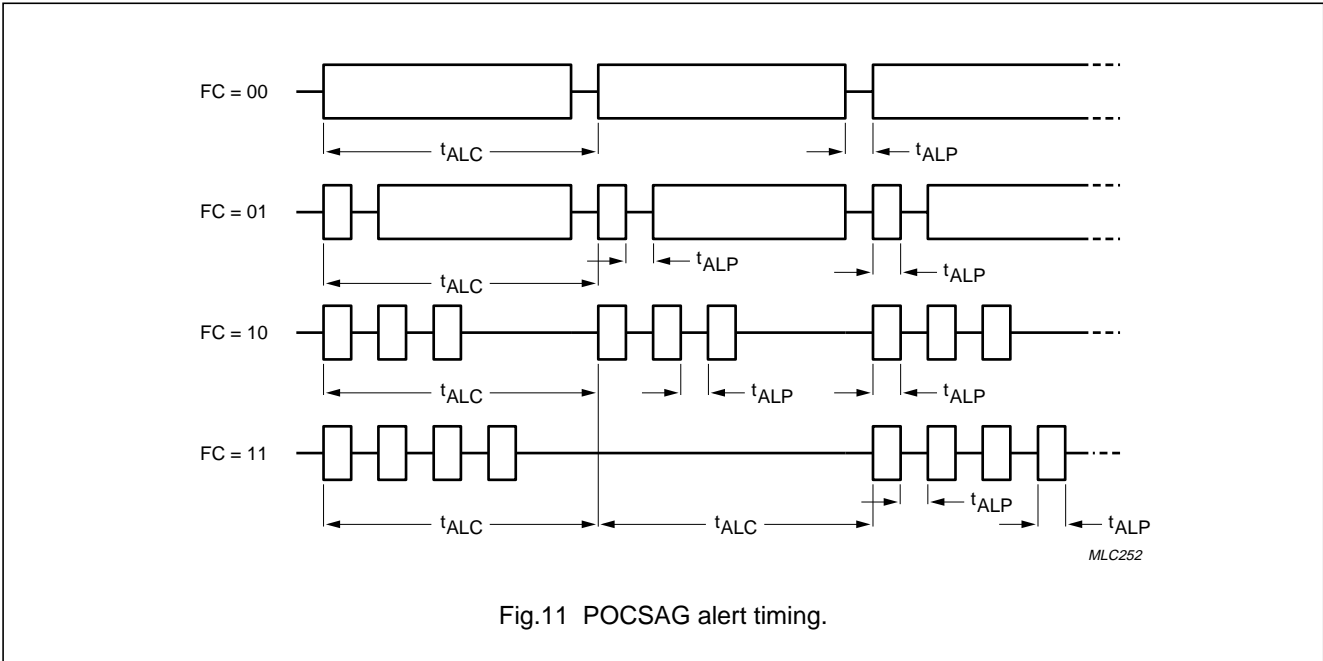

Fig.11 POCSAG alert timing.

8.44 Cancelling alerts

Standard POCSAG alerts (manual or automatic) are cancelled by resetting bit D0 in the alert set-up register. User defined alerts are cancelled by writing a zero to the alert cadence register. Any ongoing alert is cancelled when a reset pulse is applied to input RST.

8.45 Automatic POCSAG alerts

Standard alert patterns have been defined for each POCSAG call type, as indicated by the function bits in the address code-word (see Table 1). The timing of these alert patterns is shown in Fig.11. After completion of the full 16 s alert period an interrupt is generated by status bit D4.

When enabled by SPF programming (SPF byte 03, bit D2) standard POCSAG alerts will be automatically generated at outputs ATL, ATH, LED and VIB upon call reception. The alert pattern matches the call type as indicated by the function bits in the received address code-word.

The original settings of the alert set-up register will be lost. Bit D0 is reset after completion of the alert.

8.46 SRAM access

The on-chip SRAM can hold up to 96 bytes of call data. Each call consists of a call header (3 bytes), message data blocks (3 bytes per code-word) and a call terminator (3 bytes).

The RAM is filled by the decoder and can be read via the I²C-bus interface. The RAM is accessed indirectly by a read address pointer and a data output register. A write address pointer indicates the position of the last message byte stored.

Status register bit D2 is set when the read and write pointers are different. It is reset only when the SRAM pointers become equal during reading, i.e. when the RAM becomes empty.

Status bit D3 is set when the read and write pointers become equal. This can be due to a RAM empty or a RAM full condition. It is reset after a status read operation.

Interrupts are generated as follows:

- When status bit D2 is set and the receiver is disabled (RXE = 0); data is available for reading, if data fail mode (short fade recovery mode in APOC1) is not active
- Immediately when status bit D3 is set: RAM is either empty (status bit D2 = 0) or full (status bit D2 = 1).

To avoid loss of data due to RAM overflow at least 3 bytes of data must be read during reception of the code-word following the 'RAM full' interrupt.

Enhanced Pager Decoder for APOC1/POCSAG

PCD5002A

8.47 RAM write address pointer (06H; read)

The RAM write address pointer is automatically incremented during call reception, because the decoder writes each data byte to RAM. The RAM write address pointer can only be read. Values range from 00H to 5FH. Bit D7 (MSB) is not used and its value is undefined when read. When a call data byte is written to location 5FH, the write address pointer wraps around to 00H. This does not necessarily imply a RAM full condition.

8.48 RAM read address pointer (08H; read/write)

The RAM read address pointer is automatically incremented after reading a data byte via the RAM output register.

The RAM read address pointer can be accessed for reading and writing.

The values range from 00H to 5FH. When at 5FH a read operation will cause wrapping around to 00H. Bit D7 (MSB) is not used; it is ignored when written to and undefined when read from.

8.49 RAM data output register (09H; read)

The RAM data output register contains the byte addressed by the RAM read address pointer and can only be read. Each read operation causes an increment of the RAM read address pointer.

8.50 EEPROM access

The EEPROM is intended for storage of user addresses (RICs), sync words and special programmed function (SPF) bits representing the decoder configuration.

The EEPROM can store 48 bytes of information and is organized as a matrix of 8 rows by 6 columns. The EEPROM is accessed indirectly via an address pointer and a data I/O register.

The EEPROM is protected against inadvertent writing by means of the programming enable bit in the control register (bit D1).

The EEPROM memory map is non-contiguous. Figure 12 shows both the EEPROM organization and the access method.

Identifier locations contain RICs or sync words. A total of 20 unassigned bytes are available for general purpose storage.

8.51 EEPROM address pointer (07H; read/write)

An EEPROM location is addressed via the EEPROM address pointer. It is incremented automatically each time a byte is read from or written to via the EEPROM data I/O register.

The EEPROM address pointer contains two counters for the row and the column number. Bits D2 to D0 contain the column number (0 to 5) and bits D5 to D3 the row number (0 to 7). Bits D7 and D6 of the address pointer are not used. Data written to these bits will be ignored, while their values are undefined when read.

The column and row counters are connected in series. Upon overflow of the column counter (column = 5) the row counter is automatically incremented and the column counter wraps to 0. On overflow the row counter wraps from 7 to 0.

8.52 EEPROM data I/O register (0AH; read/write)

The byte addressed by the EEPROM address pointer can be written to or read from via the EEPROM data I/O register. Each access automatically increments the EEPROM address pointer.

8.53 EEPROM access limitations

Since the EEPROM address pointer is used during data decoding, the EEPROM may not be accessed while the receiver is active (RXE = 1). It is advisable to switch to the OFF state before accessing the EEPROM.

The EEPROM cannot be written to unless the EEPROM programming enable bit (bit D1) in the control register is set.

For writing a minimum programming supply voltage ($V_{DD(\text{prog})}$) is required (2.0 V typ.). The programming supply current ($I_{DD(\text{prog})}$) required during writing is approximately 500 μA .

8.54 EEPROM read operation

EEPROM read operations must start at a valid address in the non-contiguous memory map. Single byte or block reads are permitted.

8.55 EEPROM write operation

EEPROM write operations must always take place in blocks of 6 bytes, starting at the beginning of a row. Programming a single byte will reset the other bytes in the same row. Modifying a single byte in a row requires re-writing the unchanged bytes with their old contents.

Enhanced Pager Decoder for APOC1/POCSAG

PCD5002A

After writing each block a pause of 7.5 ms (max.) is required to complete the internal programming operation. During this time the external microcontroller may generate an I²C-bus STOP condition. If another I²C-bus transfer is initiated the decoder will pull SCL LOW during this pause.

After writing the EEPROM programming enable bit (D1) in, the control register must be reset.

8.56 Invalid write address

When an invalid write address is used, the column counter bits (D2 to D0) are forced to zero before being loaded into the address pointer. The row counter bits are used normally.

8.57 Incomplete programming sequence

A programming sequence may be aborted by an I²C-bus STOP condition. The EEPROM programming enable bit (D1) in the control register must then be reset.

Any bytes received from the last 6-byte block will be ignored and the contents of this (incomplete) EEPROM block will remain unchanged.

8.58 Unused EEPROM locations

A total of 20 EEPROM bytes are available for general purpose storage (see Table 22).

Table 22 Unused EEPROM addresses

ROW	HEX
0	04 and 05 ⁽¹⁾
5	28 to 2D
6	30 to 35
7	38 to 3D

Note

- When using bytes 04H and 05H, care must be taken to preserve the SPF information stored in bytes 00H to 03H.

8.59 Special programmed function allocation

The SPF bit allocation in the EEPROM is shown in Tables 23 to 27. The SPF bits are located in row 0 of the EEPROM and occupy 4 bytes.

Bytes 04H and 05H are not used and are available for general purpose storage.

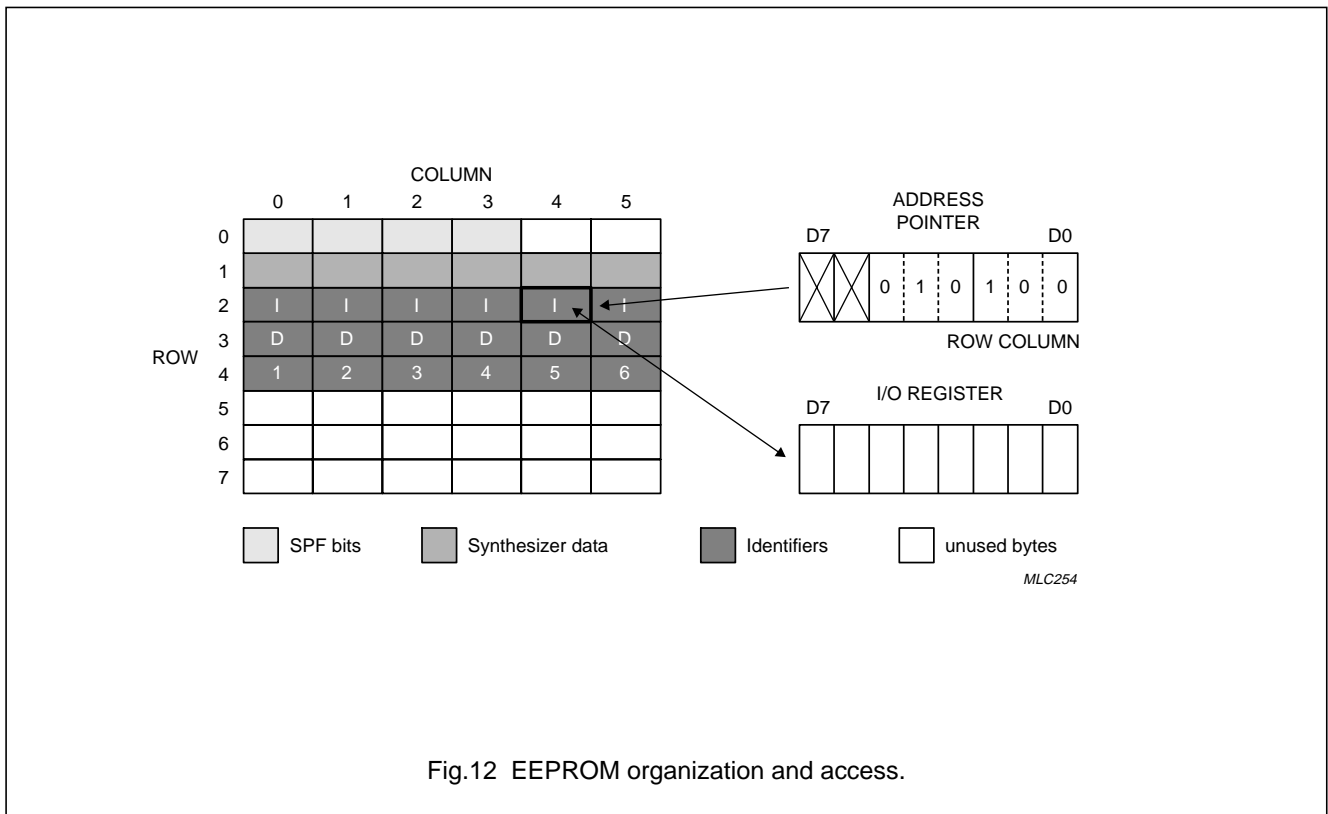

Enhanced Pager Decoder for APOC1/POCSAG

PCD5002A

Table 23 Special programmed functions (EEPROM address 00H)

BIT (MSB: D7)	VALUE	DESCRIPTION
D0	0	POCSAG decoding enabled
	1	APOC1 decoding enabled
D1	0	cycle length: 5 batches
	1	cycle length: 15 batches
D5 to D2 (MSB D5)	0 to 4	batch number (D1 = 0; MSB is ignored)
	0 to 14	batch number (D1 = 1)
D6	1	continuous data decoding enabled
D7	1	received data inversion enabled

Table 24 Special programmed functions (EEPROM address 01H)

BIT (MSB: D7)	VALUE	DESCRIPTION
D1 and D0	0 0	5 ms receiver establishment time (nominal); note 1
	0 1	10 ms receiver establishment time (nominal); note 1
	1 0	15 ms receiver establishment time (nominal); note 1
	1 1	30 ms receiver establishment time (nominal); note 1
D3 and D2	0 0	20 ms oscillator establishment time (nominal); note 1
	0 1	30 ms oscillator establishment time (nominal); note 1
	1 0	40 ms oscillator establishment time (nominal); note 1
	1 1	50 ms oscillator establishment time (nominal); note 1
D5 and D4	0 0	512 bits/s received bit rate
	0 1	1024 bits/s (not used in POCSAG)
	1 0	1200 bits/s
	1 1	2400 bits/s
D6	1	synthesizer interface enabled (programming at switch-on)
D7	1	voltage converter enabled

Note

1. Since the exact establishment time is related to the programmed bit rate, Table 25 shows the values for the various bit rates.

Enhanced Pager Decoder for APOC1/POCSAG

PCD5002A

Table 25 Establishment time as a function of bit rate

NOMINAL ESTABLISHMENT TIME	ACTUAL ESTABLISHMENT TIME			
	512 (bits/s)	1 024 (bits/s)	1 200 (bits/s)	2 400 (bits/s)
5 ms	5.9 ms (3 bits)	5.9 ms (6 bits)	5 ms (6 bits)	5 ms (12 bits)
10 ms	11.7 ms (6 bits)	11.7 ms (12 bits)	10 ms (12 bits)	10 ms (24 bits)
15 ms	15.6 ms (8 bits)	15.6 ms (16 bits)	16.7 ms (20 bits)	16.7 ms (40 bits)
20 ms	23.4 ms (12 bits)	23.4 ms (24 bits)	20 ms (24 bits)	20 ms (48 bits)
30 ms	31.2 ms (16 bits)	31.2 ms (32 bits)	26.7 ms (32 bits)	26.7 ms (64 bits)
40 ms	39.1 ms (20 bits)	39.1 ms (40 bits)	40 ms (48 bits)	40 ms (96 bits)
50 ms	46.9 ms (24 bits)	46.9 ms (48 bits)	53.3 ms (64 bits)	53.3 ms (128 bits)

Table 26 Special programmed functions (EEPROM address 02H)

BIT (MSB: D7)	VALUE	DESCRIPTION
D0	X	not used
D1	X	not used
D3 and D2	0 0	32768 Hz real-time clock reference
	0 1	50 Hz square wave
	1 0	2 Hz
	1 1	$\frac{1}{60}$ Hz
D4	1	signal test mode enabled (REF and INT outputs)
D5	0	burst error correction enabled
D7 and D6	0 0	30 s (+0.5 s max.) transmitter off time-out
	0 1	60 s (+ 1 s max.) transmitter off time-out
	1 0	120 s (+ 2 s max.) transmitter off time-out
	1 1	240 s (+ 4 s max.) transmitter off time-out

Table 27 Special programmed functions (EEPROM address 03H)

BIT (MSB: D7)	VALUE	DESCRIPTION
D1 and D0	0 0	2048 Hz acoustic alerter frequency
	0 1	2731 Hz acoustic alerter frequency
	1 0	4096 Hz acoustic alerter frequency
	1 1	3200 Hz acoustic alerter frequency
D2	1	automatic POCSAG alert generation enabled
D3	X	not used
D4	X	not used
D5	0	DQC mode 0
	1	DQC mode 1
D6	0	INT output polarity: active LOW
	1	INT output polarity: active HIGH
D7	0	standard call termination
	1	enhanced call termination

Enhanced Pager Decoder for APOC1/POCSAG

PCD5002A

8.60 Synthesizer programming data

Data for programming a PLL synthesizer via pins ZSD, ZSC and ZLE can be stored in row 1 of the EEPROM. Six bytes are available starting with address 08H.

Data is transferred in two serial blocks of 24 bits each, starting with bit 0 (MSB) of block 1. Any unused bits must be programmed at the beginning of a block.

Table 28 Synthesizer programming data (EEPROM address 08H to 0DH)

ADDRESS (HEX)	BIT (MSB: D7)	DESCRIPTION
08	D7 to D0	bits 0 to 7 of data block 1 (bit 0 is MSB)
09	D7 to D0	bits 8 to 15
0A	D7 to D0	bits 16 to 23
0B	D7 to D0	bits 0 to 7 of data block 2 (bit 0 is MSB)
0C	D7 to D0	bits 8 to 15
0D	D7 to D0	bits 16 to 23

8.61 Identifier storage allocation

Up to 6 different identifiers can be stored in EEPROM for matching with incoming data. The PCD5002A can distinguish two types of identifiers:

- User addresses (RIC)
- User Programmable Sync Words (UPSW)
- Batch zero identifiers
- Continuous Data Decoding (CDD) sync words.

Table 29 Identifier storage allocation (EEPROM address 10H to 25H)

ADDRESS (HEX)	BYTE	DESCRIPTION
10 to 15	1	identifier number 1 to 6
18 to 1D	2	identifier number 1 to 6
20 to 25	3	identifier number 1 to 6

Identifiers are stored in EEPROM rows 2, 3 and 4. Each identifier location consists of 3 bytes in the same column. The identifier number is equal to the column number + 1.

Each identifier can be individually enabled. The standard POCSAG sync word is always enabled and has identifier number 7.

The identifier type is determined by bits D2 and D0 of identifier byte 3, as shown in Table 31.

Identifiers 1 and 2 always represent RICs or batch zero identifiers. The last 4 identifiers (numbers 3 to 6) can represent any identifier type.

A UPSW represents an unused address and must differ by more than 6 bits from preamble to guarantee detection.

A batch zero identifier marks the start of a new cycle in the APOC1 protocol. It is only recognized when APOC1 decoding has been enabled (SPF byte 00, bit D0).

Reception of a CDD sync word initiates continuous data decoding. CDD sync words are only recognized when continuous data decoding has been enabled (SPF byte 00, bit 6).

Table 29 shows the memory locations of the 6 identifiers. The bit allocation per identifier is given in Table 30.

Enhanced Pager Decoder for APOC1/POCSAG

PCD5002A

Table 30 Identifier bit allocation

BYTE	BIT (MSB: D7)	DESCRIPTION
1	D7 to D0	bits 2 to 9 of POCSAG code-word (RIC or UPSW); notes 1 and 2
2	D7 to D0	bits 10 to 17
3	D7 and D6	bits 18 and 19
	D5	frame number bit FR3 (RIC); note 3
	D4	frame number bit FR2 (RIC)
	D3	frame number bit FR1 (RIC)
	D2	identifier type selection (0 = UPSW, 1 = RIC); note 4
	D1	identifier enable (1 = enabled)
	D0	batch zero ID/continuous decoding (1 = enabled)

Notes

- The bit numbering corresponds with the numbering in a POCSAG code-word; bit 1 is the flag bit (0 = address, 1 = message).
- A UPSW needs 18 bits to be matched for successful identification. Bit 1 (MSB) must be logic 0. Bits 2 to 19 contain the identifier bit pattern, they are followed by 2 predetermined random (function) bits and the UPSW is completed by 10 CRC error correction bits and an even-parity bit.
- Bits FR3 to FR1 (MSB: FR3) contain the 3 least significant bits of the 21-bit RIC.
- Identifiers 1 and 2 (RIC only) will be disabled by programming bit D2 as logic 0.

Table 31 Identifier types

BYTE 3; BIT D2	BYTE 3; BIT D0	DESCRIPTION
0	0	user programmable sync word
0	1	continuous data decoding sync word
1	0	normal user address (RIC)
1	1	batch zero identifier

8.62 Voltage doubler

An on-chip voltage doubler provides an unregulated DC output for supplying an LCD or a low power microcontroller at output V_{PO} . An external ceramic capacitor of 100 nF (typ.) is required between pins CCN and CCP. The voltage doubler is enabled via SPF programming.

8.63 Level-shifted interface

All interface lines are suited for communication with a microcontroller operating from a higher supply voltage. The external device must have a common reference at V_{SS} of the PCD5002A.

The reference voltage for the level-shifted interface must be applied to input V_{PR} . If required this could be the on-chip voltage doubler output V_{PO} . When the microcontroller has a separate (regulated) supply it should be connected to V_{PR} .

The level-shifted interface lines are RST, DON, ALC, REF and INT.

The I²C-bus interface lines SDA and SCL can be level-shifted independently of V_{PR} by the standard external pull-up resistors.

8.64 Signal test mode

A special 'signal test' mode is available for monitoring the performance of a receiver circuit together with the front-end of the PCD5002A.

For this purpose the output of the digital noise filter and the recovered bit clock are made available at outputs REF and INT respectively. All synchronization and decoding functions are normally active.

The 'signal test' mode is activated/deactivated by SPF programming.

Enhanced Pager Decoder for APOC1/POCSAG

PCD5002A

9 OPERATING INSTRUCTIONS

9.1 Reset conditions

When the PCD5002A is reset by applying a HIGH level to input RST, the condition of the decoder is as follows:

- OFF status (irrespective of DON input level)
- REF output frequency 32768 Hz
- All internal counters reset
- Status/control register reset
- All interrupts enabled
- No alert transducers selected
- LED, VIB and ATH outputs at LOW level
- ATL output high-impedance
- SDA and SCL inputs high-impedance
- Voltage converter disabled.

The programmed functions are activated within t_{RSU} after release of the reset condition (RST LOW). The settings affecting the external operation of the PCD5002A are as follows:

- REF output frequency
- Voltage converter
- INT output polarity
- Signal test mode.

When input DON is HIGH, the decoder starts operating in ON status immediately following t_{RSU} .

9.2 Power-on reset circuit

During power-up of the PCD5002A a HIGH level of minimum duration $t_{RST} = 50 \mu s$ must be applied to pin RST. This is to prevent EEPROM corruption which might otherwise occur because of the undefined contents of the control register.

The reset signal can be applied by the external microcontroller or by an RC power-on reset circuit on pin RST (C to V_{PR} , R to V_{SS}). Such an RC-circuit should have a time constant of at least $3t_{RST} = 150 \mu s$.

Input RST has an internal high-ohmic pull-down resistor (nominal 2 M Ω at 2.5 V supply) which could be used together with a suitable external capacitor connected to V_{PR} to create a power-on reset signal. However, since this pull-down resistor varies considerably with processing and supply voltage, the resulting time constant is inaccurate.

A more accurate reset duration can be realised with an additional external resistor connected to V_{SS} .

Recommended minimum values in this case are $C = 2.2 \text{ nF}$ and $R = 100 \text{ k}\Omega$ (see Fig.17).

9.3 Reset timing

The start-up time for the crystal oscillator may exceed 1 s (typ. 800 ms). It is advisable to apply a reset condition, at least during the first part of this period. The minimum reset pulse duration t_{RST} is 50 μs .

During reset the oscillator is active, but clock signals are inhibited internally. Once the reset condition is released the end of the oscillator start-up period can be detected by a rising edge on output INT.

During a reset the voltage converter clock (V_{clk}) is held at zero. The resulting output voltage drop may cause problems when the external resetting device is powered by the internal voltage doubler. A sufficiently large buffer capacitor connected between output V_{PO} and V_{SS} must be provided to supply the microcontroller during reset. The voltage at V_{PO} will not drop below $V_{DD} - 0.7 \text{ V}$.

Immediately after a reset all programmable internal functions will start operating according to a programmed value of 0. During the first 8 full clock cycles (t_{RSU}) all programmed values are loaded from EEPROM.

After reset the receiver outputs RXE and ROE become active immediately, if DON is HIGH and the synthesizer is disabled. When the synthesizer is enabled, RXE and ROE will only become active after the second pulse on ZLE completes the loading of synthesizer data.

The full reset timing is illustrated in Fig.13. The start-up timing including synthesizer programming is illustrated in Fig.14.

9.4 Initial programming

A newly-delivered PCD5002A has EEPROM contents which are undefined. The EEPROM should therefore be programmed, followed by a reset to activate the SPF settings, before any attempt is made to use the device.

Enhanced Pager Decoder for
APOC1/POCSAG

PCD5002A

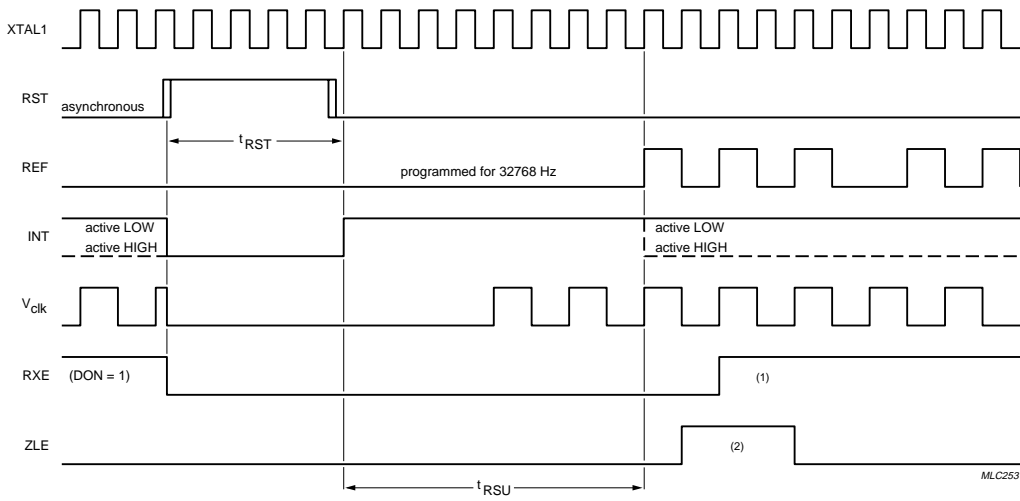

- (1) The RXE output signal is shown for disabled synthesizer. When the synthesizer is enabled RXE is held off until after the second pulse on ZLE (programming complete).
- (2) The ZLE output signal is shown for enabled synthesizer and DON = 1. When DON = 0 output ZLE remains HIGH until ON state is entered (DON = 1 or control register bit D4 = 1).

Fig.13 Reset timing.

Enhanced Pager Decoder for
APOC1/POCSAG

PCD5002A

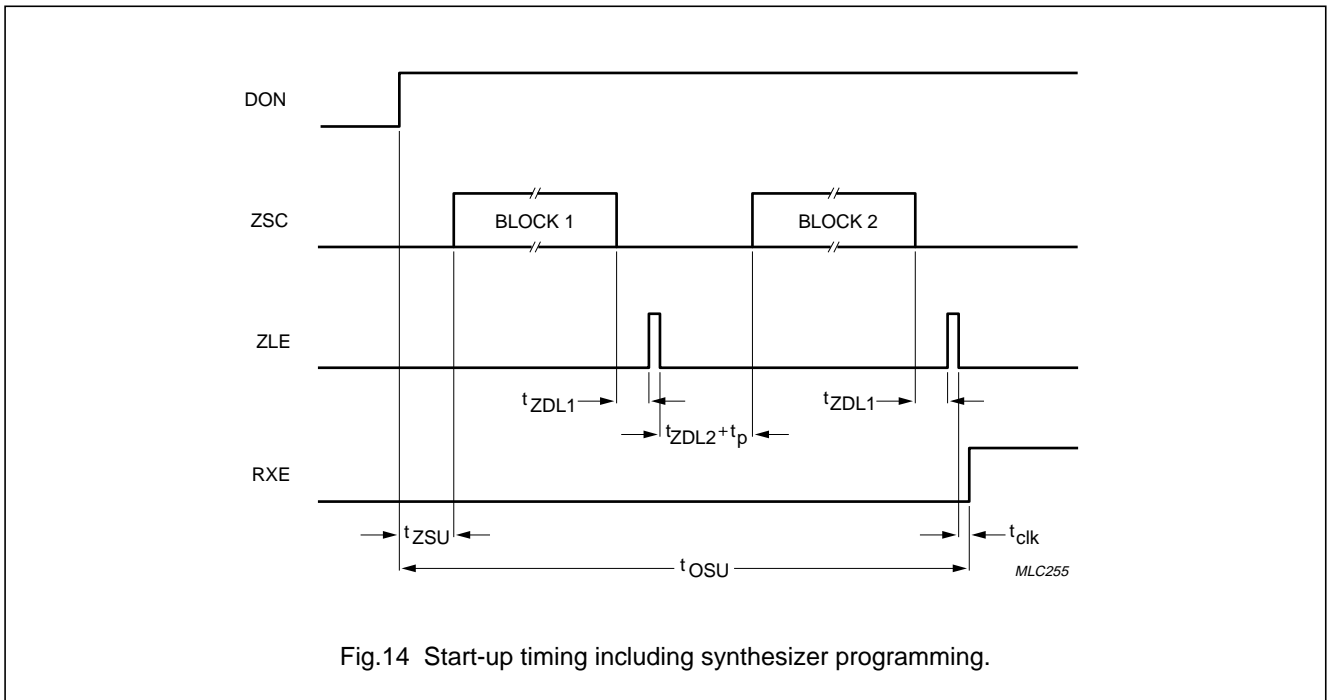

10 LIMITING VALUES

In accordance with the Absolute Maximum Rating System (IEC 134).

SYMBOL	PARAMETER	CONDITIONS	MIN.	MAX.	UNIT
V_{DD}	supply voltage		-0.5	+7.0	V
V_{PR}	external reference voltage input	$V_{PR} \geq V_{DD} - 0.8 \text{ V}$	-0.5	+7.0	V
V_n	voltage on pins ALC, DON, RST, SDA and SCL	$V_n \leq 7.0 \text{ V}$	$V_{SS} - 0.8$	$V_{PR} + 0.8$	V
V_{n1}	input voltage on any other pin	$V_{n1} \leq 7.0 \text{ V}$	$V_{SS} - 0.8$	$V_{DD} + 0.8$	V
P_{tot}	total power dissipation		-	250	mW
P_{out}	power dissipation per output		-	100	mW
T_{amb}	operating ambient temperature		-25	+70	°C
T_{stg}	storage temperature		-55	+125	°C

Enhanced Pager Decoder for APOC1/POCSAG

PCD5002A

11 DC CHARACTERISTICS

$V_{DD} = 2.7\text{ V}$; $V_{PR} = 2.7\text{ V}$; $V_{SS} = 0\text{ V}$; $T_{amb} = -25\text{ to }+70\text{ }^{\circ}\text{C}$; unless otherwise specified.

SYMBOL	PARAMETER	CONDITIONS	MIN.	TYP.	MAX.	UNIT
Supplies						
V_{DD}	supply voltage	voltage converter disabled	1.5	2.7	6.0	V
V_{PR}	external reference voltage input	$V_{PR} \geq V_{DD} - 0.8\text{ V}$	1.5	2.7	6.0	V
$V_{DD(\text{prog})}$	programming supply voltage	voltage converter disabled	2.0	–	6.0	V
		voltage converter enabled	2.0	–	3.0	V
I_{DD0}	supply current (OFF)	note 1	–	25.0	40.0	μA
I_{DD1}	supply current (ON)	note 1; $\text{DON} = V_{DD}$	–	50.0	80.0	μA
$I_{DD(\text{prog})}$	programming supply current		–	–	800	μA
Inputs						
V_{IL}	LOW-level input voltage pins RDI and BAT DON, ALC and RST SDA and SCL		V_{SS}	–	$0.3V_{DD}$	V
			V_{SS}	–	$0.3V_{PR}$	V
			V_{SS}	–	$0.3V_{DD}$	V
V_{IH}	HIGH-level input voltage pins RDI and BAT DON, ALC and RST SDA and SCL		$0.7V_{DD}$	–	V_{DD}	V
			$0.7V_{PR}$	–	V_{PR}	V
			$0.7V_{DD}$	–	V_{PR}	V
I_{IL}	LOW-level input current pins RDI, BAT, TS1, TS2, DON, ALC and RST	$T_{amb} = 25\text{ }^{\circ}\text{C}$; $V_I = V_{SS}$	0	–	–0.5	μA
I_{IH}	HIGH-level input current pins TS1 and TS2 RDI and BAT RDI and BAT DON, ALC and RST	$T_{amb} = 25\text{ }^{\circ}\text{C}$ $V_I = V_{DD}$	6	–	20	μA
		$V_I = V_{DD}$; RXE = 0	6	–	20	μA
		$V_I = V_{DD}$; RXE = 1	0	–	0.5	μA
		$V_I = V_{PR}$	250	500	850	nA
Outputs						
I_{OL}	LOW-level output current pins VIB and LED ATH INT and REF ZSD, ZSC and ZLE ATL ROE, RXE and DQC	$T_{amb} = 25\text{ }^{\circ}\text{C}$ $V_{OL} = 0.3\text{ V}$	80	–	–	μA
		$V_{OL} = 0.3\text{ V}$	250	–	–	μA
		$V_{OL} = 0.3\text{ V}$	80	–	–	μA
		$V_{OL} = 0.3\text{ V}$	70	–	–	μA
		$V_{OL} = 1.2\text{ V}$; note 2	13	27	55	mA
		$V_{OL} = 0.3\text{ V}$	80	–	–	μA

Enhanced Pager Decoder for APOC1/POCSAG

PCD5002A

SYMBOL	PARAMETER	CONDITIONS	MIN.	TYP.	MAX.	UNIT
I _{OH}	HIGH-level output current pins	T _{amb} = 25 °C				
	VIB, LED and DQC	V _{OH} = 0.7 V	-0.6	-	-2.4	mA
	ATH	V _{OH} = 0.7 V	-3.0	-	-11.0	mA
	INT and REF	V _{OH} = 2.4 V	-80	-	-	μA
	ZSD, ZSC and ZLE	V _{OH} = 2.4 V	-60	-	-	μA
	ATL	ATL high-impedance; note 3	-	-	-0.5	μA
	ROE and RXE	V _{OH} = 2.4 V	-600	-	-	μA

Notes

- Inputs: SDA and SCL pulled up to V_{DD}; all other inputs connected to V_{SS}.
Outputs: RXE and ROE logic 0; REF: f_{ref} = 1/60 Hz; all other outputs open-circuit.
Oscillator: no crystal; external clock f_{osc} = 76800 Hz; amplitude: V_{SS} to V_{DD}.
Voltage convertor disabled (SPF byte 01, bit D7 = 0; see Table 24).
- Maximum output current is subject to absolute maximum ratings per output (see Chapter 10).
- When ATL (open-drain output) is not activated it is high impedance.

12 DC CHARACTERISTICS (WITH VOLTAGE CONVERTER)

V_{DD} = 2.7 V; V_{SS} = 0 V; V_{PR} = V_{PO}; T_{amb} = -25 to +70 °C; C_s = 100 nF; voltage convertor enabled.

SYMBOL	PARAMETER	CONDITIONS	MIN.	TYP.	MAX.	UNIT
V _{DD}	supply voltage		1.5	-	3.0	V
V _{PO(0)}	output voltage; no load	V _{DD} = 2.7 V; I _{PO} = 0	-	5.4	-	V
V _{PO}	output voltage	V _{DD} = 2 V; I _{PO} = -250 μA	3.0	3.5	-	V
I _{PO}	output current	V _{DD} = 2 V; V _{PO} = 2.7 V	-400	-650	-	μA
		V _{DD} = 3 V; V _{PO} = 4.5 V	-650	-900	-	μA

13 OSCILLATOR CHARACTERISTICS

Quartz crystal type: MX-1V or equivalent. Quartz crystal parameters: f = 76 800 Hz; R_{S(max)} = 35 kΩ; C_L = 8 pF; C₀ = 1.4 pF; C₁ = 1.5 fF. Maximum overall tolerance: ±200 × 10⁻⁶ (includes: cutting, temperature, aging) for POCSAG, ±55 × 10⁻⁶ for APOC1 ('transmitter off' mode).

SYMBOL	PARAMETER	CONDITIONS	MIN.	TYP.	UNIT
C _{XO}	output capacitance XTAL2		-	10	pF
g _m	oscillator transconductance	V _{DD} = 1.5 V	6	12	μS

Enhanced Pager Decoder for APOC1/POCSAG

PCD5002A

14 AC CHARACTERISTICS

$V_{DD} = 2.7\text{ V}$; $V_{SS} = 0\text{ V}$; $V_{PR} = 2.7\text{ V}$; $T_{amb} = 25\text{ °C}$; $f_{osc} = 76800\text{ Hz}$.

SYMBOLS	PARAMETER	CONDITIONS	MIN.	TYP.	MAX.	UNIT
System clock						
T_{clk}	system clock period	$f_{osc} = 76800\text{ Hz}$	–	13.02	–	μs
Call alert frequencies						
f_{AL}	alert frequency	SPF byte 03H; bits D1 and D0 = 0 0	–	2048	–	Hz
		D1 and D0 = 0 1	–	2731	–	Hz
		D1 and D0 = 1 0	–	3200	–	Hz
		D1 and D0 = 1 1	–	4096	–	Hz
f_{AW}	warbled alert; modulation frequency	alert set-up bit D2 = 1; outputs ATL, ATH and LED	–	16	–	Hz
f_{AWH}	warbled alert; high acoustic alert frequency	alert set-up bit D2 = 1; outputs ATL and ATH	–	f_{AL}	–	Hz
f_{AWL}	warbled alert; low acoustic alert frequency	alert set-up bit D2 = 1; outputs ATL and ATH	–	$\frac{1}{2}f_{AL}$	–	Hz
f_{VBP}	pulsed vibrator frequency (square wave)	low-level alert	–	25	–	Hz
Call alert duration						
t_{ALT}	alert time-out period		–	16	–	s
t_{ALL}	ATL output time-out period	low-level alert	–	4	–	s
t_{ALH}	ATH output time-out period	high-level alert	–	12	–	s
t_{VBL}	VIB output time-out period	low-level alert	–	4	–	s
t_{VBH}	VIB output time-out period	high-level alert	–	12	–	s
t_{ALC}	alert cycle period		–	1	–	s
t_{ALP}	alert pulse duration		–	125	–	ms
Real-time clock reference						
f_{ref}	real-time clock reference frequency	SPF byte 02H; bits D3 and D2 = 0 0; note 1	–	32768	–	Hz
		D3 and D2 = 0 1; note 2	–	50	–	Hz
		D3 and D2 = 1 0	–	2	–	Hz
		D3 and D2 = 1 1	–	$\frac{1}{60}$	–	Hz
t_{RFP}	real-time clock reference pulse duration	all reference frequencies except 50 Hz (square wave)	–	13.02	–	μs

Enhanced Pager Decoder for APOC1/POCSAG

PCD5002A

SYMBOLS	PARAMETER	CONDITIONS	MIN.	TYP.	MAX.	UNIT
Receiver control						
t _{RXT}	RXE and ROE transition time	C _L = 5 pF	–	100	–	ns
t _{RXON}	RXE establishment time (nominal values: actual duration is bit rate dependent, see Table 25)	SPF byte 01H; bits D1 and D0 = 0 0	–	5	–	ms
		D1 and D0 = 0 1	–	10	–	ms
		D1 and D0 = 1 0	–	15	–	ms
		D1 and D0 = 1 1	–	30	–	ms
t _{ROON}	ROE establishment time (nominal values: actual duration is bit rate dependent, see Table 25)	SPF byte 01H; bits D3 and D2 = 0 0	–	20	–	ms
		D3 and D2 = 0 1	–	30	–	ms
		D3 and D2 = 1 0	–	40	–	ms
		D3 and D2 = 1 1	–	50	–	ms
I²C-bus interface						
f _{SCL}	SCL clock frequency		0	–	100	kHz
t _{LOW}	SCL clock low period		4.7	–	–	μs
t _{HIGH}	SCL clock HIGH period		4.0	–	–	μs
t _{SU;DAT}	data set-up time		250	–	–	ns
t _{HD;DAT}	data hold time		500	–	–	ns
t _r	SDA and SCL rise time		–	–	1000	ns
t _f	SDA and SCL fall time		–	–	300	ns
C _B	capacitive bus line load		–	–	400	pF
t _{SU;STA}	START condition set-up time		4.7	–	–	μs
t _{HD;STA}	START condition hold time		4.0	–	–	μs
t _{SU;STO}	STOP condition set-up time		4.0	–	–	μs
Reset						
t _{RST}	external reset duration		50	–	–	μs
t _{RSU}	set-up time after reset	oscillator running	–	–	105	μs
t _{OSU}	set-up time after switch-on	oscillator running	–	–	4	ms
Data input						
t _{TDI}	data input transition time	see Fig.15	–	–	100	μs
t _{DI1}	data input logic 1 duration	see Fig.15	t _{BIT}	–	∞	
t _{DI0}	data input logic 0 duration	see Fig.15	t _{BIT}	–	∞	
POCSAG data timing (512 bits/s)						
f _{DI}	data input rate	SPF byte 01H; D5 = 0; D4 = 0	–	512	–	bits/s
t _{BIT}	bit duration		–	1.9531	–	ms
t _{CW}	code-word duration		–	62.5	–	ms
t _{PA}	preamble duration		1 125	–	–	ms
t _{BAT}	batch duration		–	1062.5	–	ms

Enhanced Pager Decoder for APOC1/POCSAG

PCD5002A

SYMBOLS	PARAMETER	CONDITIONS	MIN.	TYP.	MAX.	UNIT
POCSAG data timing (1200 bits/s)						
f _{DI}	data input rate	SPF byte 01H; D5 = 1; D4 = 0	–	1200	–	bits/s
t _{BIT}	bit duration		–	833.3	–	μs
t _{CW}	code-word duration		–	26.7	–	ms
t _{PA}	preamble duration		480	–	–	ms
t _{BAT}	batch duration		–	453.3	–	ms
POCSAG data timing (2400 bits/s)						
f _{DI}	data input rate	SPF byte 01H; D5 = 1; D4 = 1	–	2400	–	bits/s
t _{BIT}	bit duration		–	416.6	–	μs
t _{CW}	code-word duration		–	13.3	–	ms
t _{PA}	preamble duration		240	–	–	ms
t _{BAT}	batch duration		–	226.6	–	ms
APOC1 batch timing						
t _{SB}	cycle duration	SPF byte 00H; bit D2 = 0 (5 batches)	–	2720	–	bits
		SPF byte 00H; bit D2 = 0 (15 batches)	–	8160	–	bits
Synthesizer control						
t _{ZSU}	synthesizer set-up duration	oscillator running; note 3	1	–	2	bits
f _{ZSC}	output clock frequency	note 4	–	38400	–	Hz
t _{ZCL}	clock pulse duration		–	13.02	–	μs
t _{ZSD}	data bit duration	note 4	–	26.04	–	μs
t _{ZDS}	data bit set-up time		–	13.02	–	μs
t _{ZDL1}	data load enable delay		–	91.15	–	μs
t _{ZLE}	load enable pulse duration		–	13.02	–	μs
t _{ZDL2}	inter block delay		–	117.19	–	μs

Notes

- 32768 Hz reference signal; 32 pulses per 75 clock cycles, alternately separated by 1 or 2 pulse periods (pulse duration: t_{RFP}). The timing is shown in Fig.16.
- 50 Hz reference signal: square wave.
- Duration depends on programmed bit rate; after reset t_{ZSU} = 1.5 bits.
- Nominal values; pause in 12th data bit (see Table 11).

Enhanced Pager Decoder for
APOC1/POCSAG

PCD5002A

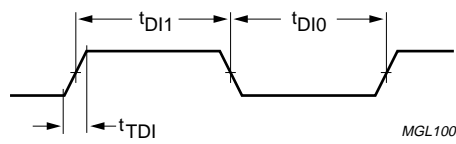

Fig.15 Data input timing.

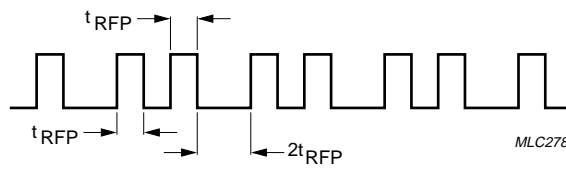

Fig.16 Timing of the 32.768 Hz reference signal.

Enhanced Pager Decoder for APOC1/POCSAG

PCD5002A

16 PACKAGE OUTLINE

LQFP32: plastic low profile quad flat package; 32 leads; body 7 x 7 x 1.4 mm

SOT358-1

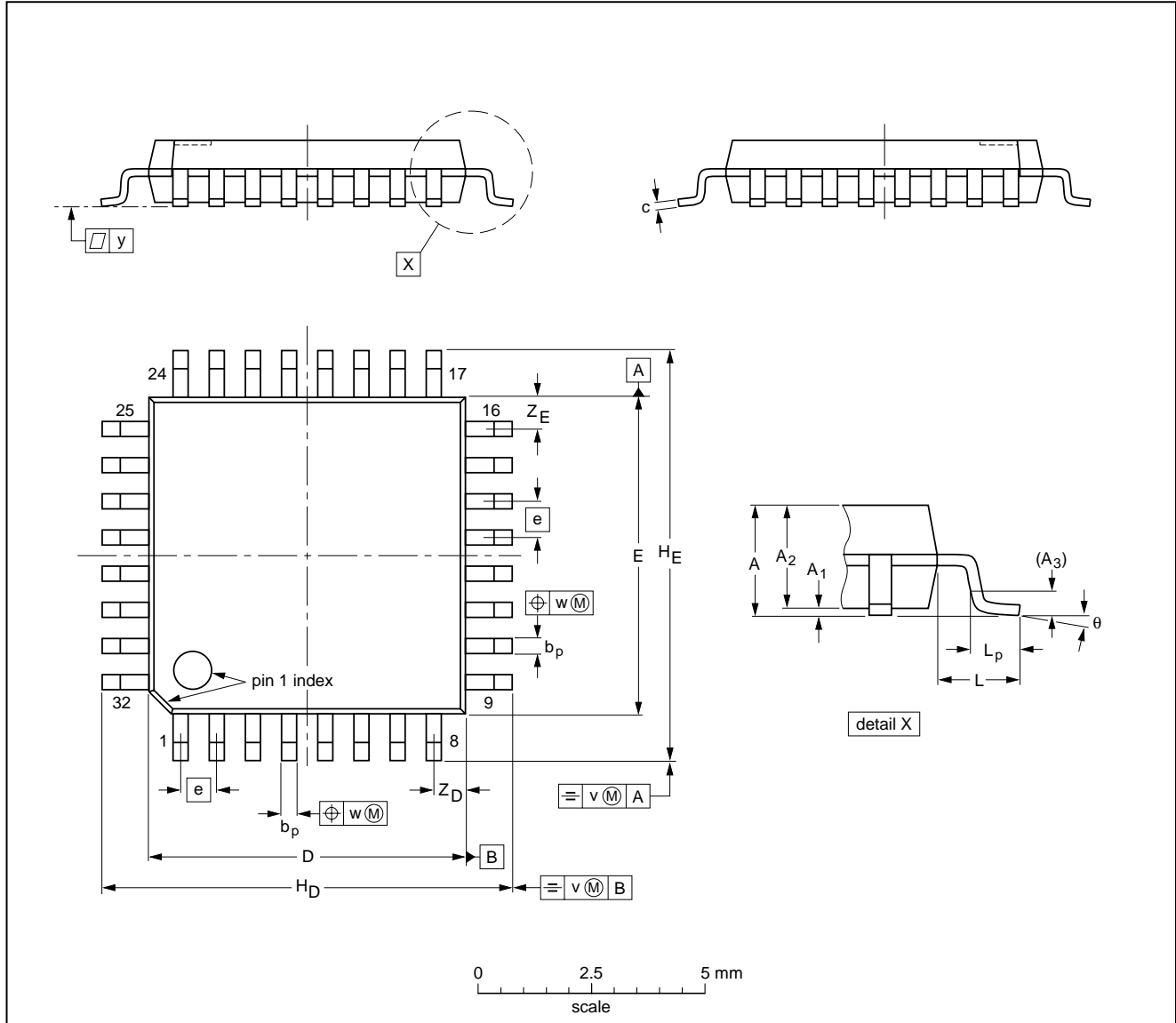

DIMENSIONS (mm are the original dimensions)

UNIT	A max.	A ₁	A ₂	A ₃	b _p	c	D ⁽¹⁾	E ⁽¹⁾	e	H _D	H _E	L	L _p	v	w	y	Z _D ⁽¹⁾	Z _E ⁽¹⁾	θ
mm	1.60	0.20 0.05	1.45 1.35	0.25	0.4 0.3	0.18 0.12	7.1 6.9	7.1 6.9	0.8	9.15 8.85	9.15 8.85	1.0	0.75 0.45	0.2	0.25	0.1	0.9 0.5	0.9 0.5	7° 0°

Note

1. Plastic or metal protrusions of 0.25 mm maximum per side are not included.

OUTLINE VERSION	REFERENCES				EUROPEAN PROJECTION	ISSUE DATE
	IEC	JEDEC	EIAJ			
SOT358 -1						95-12-19 97-08-04

Enhanced Pager Decoder for APOC1/POCSAG

PCD5002A

17 SOLDERING

17.1 Introduction to soldering surface mount packages

This text gives a very brief insight to a complex technology. A more in-depth account of soldering ICs can be found in our *"Data Handbook IC26; Integrated Circuit Packages"* (document order number 9398 652 90011).

There is no soldering method that is ideal for all surface mount IC packages. Wave soldering is not always suitable for surface mount ICs, or for printed-circuit boards with high population densities. In these situations reflow soldering is often used.

17.2 Reflow soldering

Reflow soldering requires solder paste (a suspension of fine solder particles, flux and binding agent) to be applied to the printed-circuit board by screen printing, stencilling or pressure-syringe dispensing before package placement.

Several methods exist for reflowing; for example, infrared/convection heating in a conveyor type oven. Throughput times (preheating, soldering and cooling) vary between 100 and 200 seconds depending on heating method.

Typical reflow peak temperatures range from 215 to 250 °C. The top-surface temperature of the packages should preferably be kept below 230 °C.

17.3 Wave soldering

Conventional single wave soldering is not recommended for surface mount devices (SMDs) or printed-circuit boards with a high component density, as solder bridging and non-wetting can present major problems.

To overcome these problems the double-wave soldering method was specifically developed.

If wave soldering is used the following conditions must be observed for optimal results:

- Use a double-wave soldering method comprising a turbulent wave with high upward pressure followed by a smooth laminar wave.
- For packages with leads on two sides and a pitch (e):
 - larger than or equal to 1.27 mm, the footprint longitudinal axis is **preferred** to be parallel to the transport direction of the printed-circuit board;
 - smaller than 1.27 mm, the footprint longitudinal axis **must** be parallel to the transport direction of the printed-circuit board.

The footprint must incorporate solder thieves at the downstream end.

- For packages with leads on four sides, the footprint must be placed at a 45° angle to the transport direction of the printed-circuit board. The footprint must incorporate solder thieves downstream and at the side corners.

During placement and before soldering, the package must be fixed with a droplet of adhesive. The adhesive can be applied by screen printing, pin transfer or syringe dispensing. The package can be soldered after the adhesive is cured.

Typical dwell time is 4 seconds at 250 °C.

A mildly-activated flux will eliminate the need for removal of corrosive residues in most applications.

17.4 Manual soldering

Fix the component by first soldering two diagonally-opposite end leads. Use a low voltage (24 V or less) soldering iron applied to the flat part of the lead. Contact time must be limited to 10 seconds at up to 300 °C.

When using a dedicated tool, all other leads can be soldered in one operation within 2 to 5 seconds between 270 and 320 °C.

Enhanced Pager Decoder for APOC1/POCSAG

PCD5002A

17.5 Suitability of surface mount IC packages for wave and reflow soldering methods

PACKAGE	SOLDERING METHOD	
	WAVE	REFLOW ⁽¹⁾
HLQFP, HSQFP, HSOP, SMS	not suitable ⁽²⁾	suitable
PLCC ⁽³⁾ , SO	suitable	suitable
LQFP, QFP, TQFP	not recommended ⁽³⁾⁽⁴⁾	suitable
SQFP	not suitable	suitable
SSOP, TSSOP, VSO	not recommended ⁽⁵⁾	suitable

Notes

- All surface mount (SMD) packages are moisture sensitive. Depending upon the moisture content, the maximum temperature (with respect to time) and body size of the package, there is a risk that internal or external package cracks may occur due to vaporization of the moisture in them (the so called popcorn effect). For details, refer to the Drypack information in the *"Data Handbook IC26; Integrated Circuit Packages; Section: Packing Methods"*.
- These packages are not suitable for wave soldering as a solder joint between the printed-circuit board and heatsink (at bottom version) can not be achieved, and as solder may stick to the heatsink (on top version).
- If wave soldering is considered, then the package must be placed at a 45° angle to the solder wave direction. The package footprint must incorporate solder thieves downstream and at the side corners.
- Wave soldering is only suitable for LQFP, TQFP and QFP packages with a pitch (e) equal to or larger than 0.8 mm; it is definitely not suitable for packages with a pitch (e) equal to or smaller than 0.65 mm.
- Wave soldering is only suitable for SSOP and TSSOP packages with a pitch (e) equal to or larger than 0.65 mm; it is definitely not suitable for packages with a pitch (e) equal to or smaller than 0.5 mm.

Enhanced Pager Decoder for APOC1/POCSAG

PCD5002A

18 DEFINITIONS

Data sheet status	
Objective specification	This data sheet contains target or goal specifications for product development.
Preliminary specification	This data sheet contains preliminary data; supplementary data may be published later.
Product specification	This data sheet contains final product specifications.
Limiting values	
Limiting values given are in accordance with the Absolute Maximum Rating System (IEC 134). Stress above one or more of the limiting values may cause permanent damage to the device. These are stress ratings only and operation of the device at these or at any other conditions above those given in the Characteristics sections of the specification is not implied. Exposure to limiting values for extended periods may affect device reliability.	
Application information	
Where application information is given, it is advisory and does not form part of the specification.	

19 LIFE SUPPORT APPLICATIONS

These products are not designed for use in life support appliances, devices, or systems where malfunction of these products can reasonably be expected to result in personal injury. Philips customers using or selling these products for use in such applications do so at their own risk and agree to fully indemnify Philips for any damages resulting from such improper use or sale.

20 PURCHASE OF PHILIPS I²C COMPONENTS



Purchase of Philips I²C components conveys a license under the Philips' I²C patent to use the components in the I²C system provided the system conforms to the I²C specification defined by Philips. This specification can be ordered using the code 9398 393 40011.

Enhanced Pager Decoder for
APOC1/POCSAG

PCD5002A

NOTES

Philips Semiconductors – a worldwide company

Argentina: see South America

Australia: 34 Waterloo Road, NORTH RYDE, NSW 2113, Tel. +61 2 9805 4455, Fax. +61 2 9805 4466

Austria: Computerstr. 6, A-1101 WIEN, P.O. Box 213, Tel. +43 1 60 101 1248, Fax. +43 1 60 101 1210

Belarus: Hotel Minsk Business Center, Bld. 3, r. 1211, Volodarski Str. 6, 220050 MINSK, Tel. +375 172 20 0733, Fax. +375 172 20 0773

Belgium: see The Netherlands

Brazil: see South America

Bulgaria: Philips Bulgaria Ltd., Energoproject, 15th floor, 51 James Bourchier Blvd., 1407 SOFIA, Tel. +359 2 68 9211, Fax. +359 2 68 9102

Canada: PHILIPS SEMICONDUCTORS/COMPONENTS, Tel. +1 800 234 7381, Fax. +1 800 943 0087

China/Hong Kong: 501 Hong Kong Industrial Technology Centre, 72 Tat Chee Avenue, Kowloon Tong, HONG KONG, Tel. +852 2319 7888, Fax. +852 2319 7700

Colombia: see South America

Czech Republic: see Austria

Denmark: Sydhavnsgade 23, 1780 COPENHAGEN V, Tel. +45 33 29 3333, Fax. +45 33 29 3905

Finland: Sinikalliontie 3, FIN-02630 ESPOO, Tel. +358 9 615 800, Fax. +358 9 6158 0920

France: 51 Rue Carnot, BP317, 92156 SURESNES Cedex, Tel. +33 1 4099 6161, Fax. +33 1 4099 6427

Germany: Hammerbrookstraße 69, D-20097 HAMBURG, Tel. +49 40 2353 60, Fax. +49 40 2353 6300

Greece: No. 15, 25th March Street, GR 17778 TAVROS/ATHENS, Tel. +30 1 489 4339/4239, Fax. +30 1 481 4240

Hungary: see Austria

India: Philips INDIA Ltd, Band Box Building, 2nd floor, 254-D, Dr. Annie Besant Road, Worli, MUMBAI 400 025, Tel. +91 22 493 8541, Fax. +91 22 493 0966

Indonesia: PT Philips Development Corporation, Semiconductors Division, Gedung Philips, Jl. Buncit Raya Kav.99-100, JAKARTA 12510, Tel. +62 21 794 0040 ext. 2501, Fax. +62 21 794 0080

Ireland: Newstead, Clonskeagh, DUBLIN 14, Tel. +353 1 7640 000, Fax. +353 1 7640 200

Israel: RAPAC Electronics, 7 Kehilat Saloniki St, PO Box 18053, TEL AVIV 61180, Tel. +972 3 645 0444, Fax. +972 3 649 1007

Italy: PHILIPS SEMICONDUCTORS, Piazza IV Novembre 3, 20124 MILANO, Tel. +39 2 6752 2531, Fax. +39 2 6752 2557

Japan: Philips Bldg 13-37, Kohnan 2-chome, Minato-ku, TOKYO 108-8507, Tel. +81 3 3740 5130, Fax. +81 3 3740 5077

Korea: Philips House, 260-199 Itaewon-dong, Yongsan-ku, SEOUL, Tel. +82 2 709 1412, Fax. +82 2 709 1415

Malaysia: No. 76 Jalan Universiti, 46200 PETALING JAYA, SELANGOR, Tel. +60 3 750 5214, Fax. +60 3 757 4880

Mexico: 5900 Gateway East, Suite 200, EL PASO, TEXAS 79905, Tel. +9-5 800 234 7381, Fax +9-5 800 943 0087

Middle East: see Italy

Netherlands: Postbus 90050, 5600 PB EINDHOVEN, Bldg. VB, Tel. +31 40 27 82785, Fax. +31 40 27 88399

New Zealand: 2 Wagener Place, C.P.O. Box 1041, AUCKLAND, Tel. +64 9 849 4160, Fax. +64 9 849 7811

Norway: Box 1, Manglerud 0612, OSLO, Tel. +47 22 74 8000, Fax. +47 22 74 8341

Pakistan: see Singapore

Philippines: Philips Semiconductors Philippines Inc., 106 Valero St. Salcedo Village, P.O. Box 2108 MCC, MAKATI, Metro MANILA, Tel. +63 2 816 6380, Fax. +63 2 817 3474

Poland: Ul. Lukiska 10, PL 04-123 WARSZAWA, Tel. +48 22 612 2831, Fax. +48 22 612 2327

Portugal: see Spain

Romania: see Italy

Russia: Philips Russia, Ul. Usatcheva 35A, 119048 MOSCOW, Tel. +7 095 755 6918, Fax. +7 095 755 6919

Singapore: Lorong 1, Toa Payoh, SINGAPORE 319762, Tel. +65 350 2538, Fax. +65 251 6500

Slovakia: see Austria

Slovenia: see Italy

South Africa: S.A. PHILIPS Pty Ltd., 195-215 Main Road Martindale, 2092 JOHANNESBURG, P.O. Box 7430 Johannesburg 2000, Tel. +27 11 470 5911, Fax. +27 11 470 5494

South America: Al. Vicente Pinzon, 173, 6th floor, 04547-130 SÃO PAULO, SP, Brazil, Tel. +55 11 821 2333, Fax. +55 11 821 2382

Spain: Balmes 22, 08007 BARCELONA, Tel. +34 93 301 6312, Fax. +34 93 301 4107

Sweden: Kottbygatan 7, Akalla, S-16485 STOCKHOLM, Tel. +46 8 5985 2000, Fax. +46 8 5985 2745

Switzerland: Allmendstrasse 140, CH-8027 ZÜRICH, Tel. +41 1 488 2741 Fax. +41 1 488 3263

Taiwan: Philips Semiconductors, 6F, No. 96, Chien Kuo N. Rd., Sec. 1, TAIPEI, Taiwan Tel. +886 2 2134 2865, Fax. +886 2 2134 2874

Thailand: PHILIPS ELECTRONICS (THAILAND) Ltd., 209/2 Sanpavuth-Bangna Road Prakanong, BANGKOK 10260, Tel. +66 2 745 4090, Fax. +66 2 398 0793

Turkey: Talatpasa Cad. No. 5, 80640 GÜLTEPE/ISTANBUL, Tel. +90 212 279 2770, Fax. +90 212 282 6707

Ukraine: PHILIPS UKRAINE, 4 Patrice Lumumba str., Building B, Floor 7, 252042 KIEV, Tel. +380 44 264 2776, Fax. +380 44 268 0461

United Kingdom: Philips Semiconductors Ltd., 276 Bath Road, Hayes, MIDDLESEX UB3 5BX, Tel. +44 181 730 5000, Fax. +44 181 754 8421

United States: 811 East Arques Avenue, SUNNYVALE, CA 94088-3409, Tel. +1 800 234 7381, Fax. +1 800 943 0087

Uruguay: see South America

Vietnam: see Singapore

Yugoslavia: PHILIPS, Trg N. Pasica 5/v, 11000 BEOGRAD, Tel. +381 11 62 5344, Fax. +381 11 63 5777

For all other countries apply to: Philips Semiconductors, International Marketing & Sales Communications, Building BE-p, P.O. Box 218, 5600 MD EINDHOVEN, The Netherlands, Fax. +31 40 27 24825

Internet: <http://www.semiconductors.philips.com>

© Philips Electronics N.V. 1999

SCA61

All rights are reserved. Reproduction in whole or in part is prohibited without the prior written consent of the copyright owner.

The information presented in this document does not form part of any quotation or contract, is believed to be accurate and reliable and may be changed without notice. No liability will be accepted by the publisher for any consequence of its use. Publication thereof does not convey nor imply any license under patent- or other industrial or intellectual property rights.

Printed in The Netherlands

465008/00/01/pp48

Date of release: 1999 Jan 08

Document order number: 9397 750 04676

Let's make things better.

**Philips
Semiconductors**



PHILIPS