

# DATA SHEET

**87C652/87C654**

80C51 8-bit microcontroller

8K/16K, 256 OTP, I<sup>2</sup>C

Product specification

Replaces data sheets 87C652 of 1998 May 01 and 87C654 of 1998 May 01

IC20 Data Handbook

1999 Jul 23

# 80C51 8-bit microcontroller

## 8K/16K, 256 OTP, I<sup>2</sup>C

### 87C652/87C654

#### DESCRIPTION

The 87C652/87C654 single-chip 8-Bit microcontroller is manufactured in an advanced CMOS process and is a derivative of the 80C51 microcontroller family. The 87C652/87C654 has the same instruction set as the 80C51. Three versions of the derivative exist:

80C652—ROMless

83C652/83C654—8 Kbyte, 16 Kbyte ROM

87C652/87C654—8 Kbyte, 16 Kbyte OTP

The ROMless and ROM are in separate datasheets.

This device provides architectural enhancements that make it applicable in a variety of applications for general control systems. The 87C654 contains a non-volatile 16k x 8 EPROM and the 87C652 contains an 8k x 8 EPROM. Both have a volatile 256 x 8 read/write data memory, four 8-bit I/O ports, two 16-bit timer/event counters (identical to the timers of the 80C51), a multi-source, two-priority-level, nested interrupt structure, an I<sup>2</sup>C interface, UART and on-chip oscillator and timing circuits. For systems that require extra capability, the 87C652/87C654 can be expanded using standard TTL compatible memories and logic.

The device also functions as an arithmetic processor having facilities for both binary and BCD arithmetic plus bit-handling capabilities. The instruction set consists of over 100 instructions: 49 one-byte, 45 two-byte and 17 three-byte. With a 16 MHz crystal, 58% of the instructions are executed in 0.75  $\mu$ s and 40% in 1.5  $\mu$ s. Multiply and divide instructions require 3  $\mu$ s.

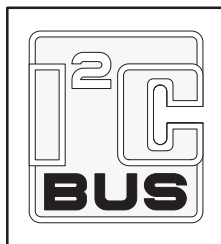

#### FEATURES

- 80C51 central processing unit
- 16k x 8 EPROM or 8k x 8 EPROM expandable externally to 64k bytes
- 256 x 8 RAM, expandable externally to 64k bytes
- Two standard 16-bit timer/counters
- Four 8-bit I/O ports
- I<sup>2</sup>C-bus serial I/O port with byte oriented master and slave functions
- Full-duplex UART facilities
- Power control modes
  - Idle mode
  - Power-down mode
- Extended temperature range
- OTP package available
- Two speed ranges
  - 16 MHz
  - 20 MHz

#### PIN CONFIGURATIONS

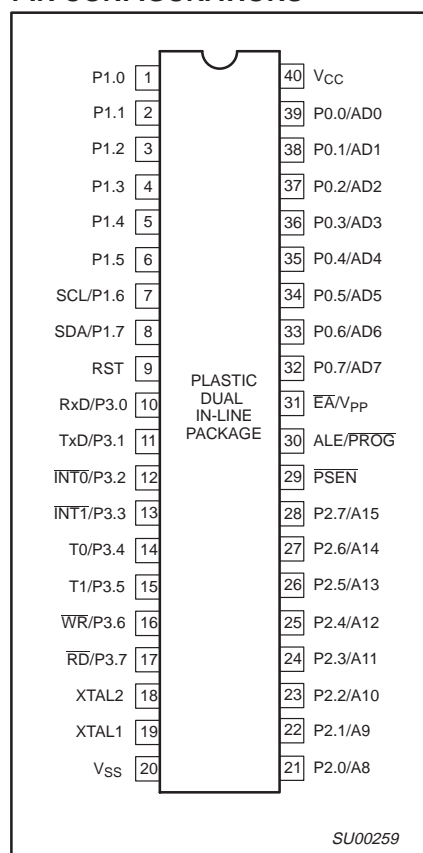

SU00259

#### ORDERING INFORMATION

EPROM	TEMPERATURE RANGE °C AND PACKAGE	FREQ MHz	Drawing Number
S87C654-4N40	0 to +70, Plastic Dual In-line Package	16	SOT129-1
S87C654-4A44	0 to +70, Plastic Leaded Chip Carrier	16	SOT187-2
S87C654-4B44	0 to +70, Plastic Quad Flat Pack	16	SOT307-2
S87C654-5N40	-40 to +85, Plastic Dual In-line Package	16	SOT129-1
S87C654-5A44	-40 to +85, Plastic Leaded Chip Carrier	16	SOT187-2
S87C654-5B44	-40 to +85, Plastic Quad Flat Pack	16	SOT307-2
S87C654-7N40	0 to +70, Plastic Dual In-line Package	20	SOT129-1
S87C654-7A44	0 to +70, Plastic Leaded Chip Carrier	20	SOT187-2
S87C652-4N40	0 to +70, Plastic Dual In-line Package	16	SOT129-1
S87C652-4A44	0 to +70, Plastic Leaded Chip Carrier	16	SOT187-2
S87C652-4B44	0 to +70, Plastic Quad Flat Pack	16	SOT307-2
S87C652-5A44	-40 to +85, Plastic Leaded Chip Carrier	16	SOT187-2

#### NOTES:

1. For ROM see 83C654 data sheet and 83C652/80C652 data sheet

# 80C51 8-bit microcontroller 8K/16K, 256 OTP, I<sup>2</sup>C

87C652/87C654

## BLOCK DIAGRAM

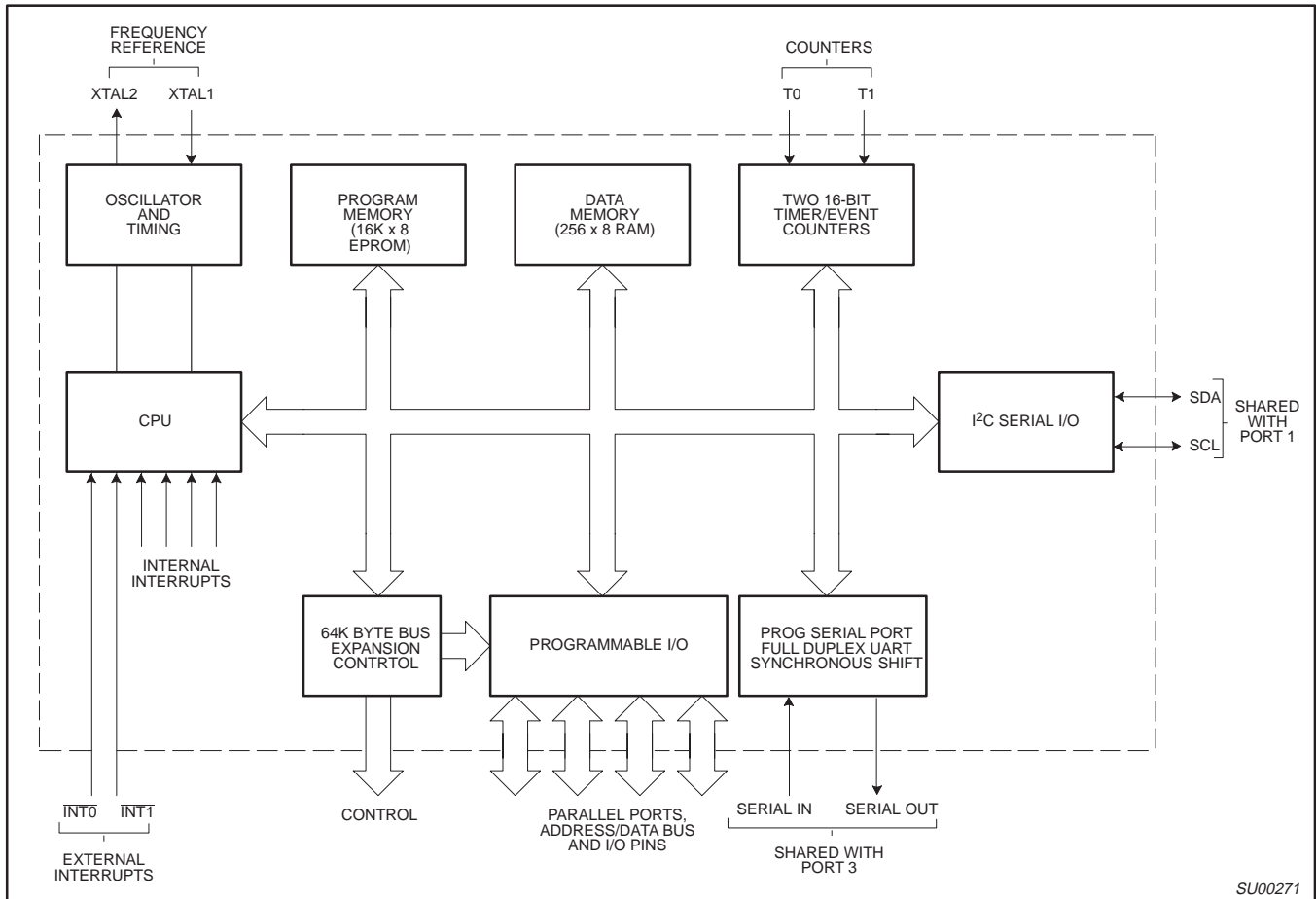

## LOGIC SYMBOL

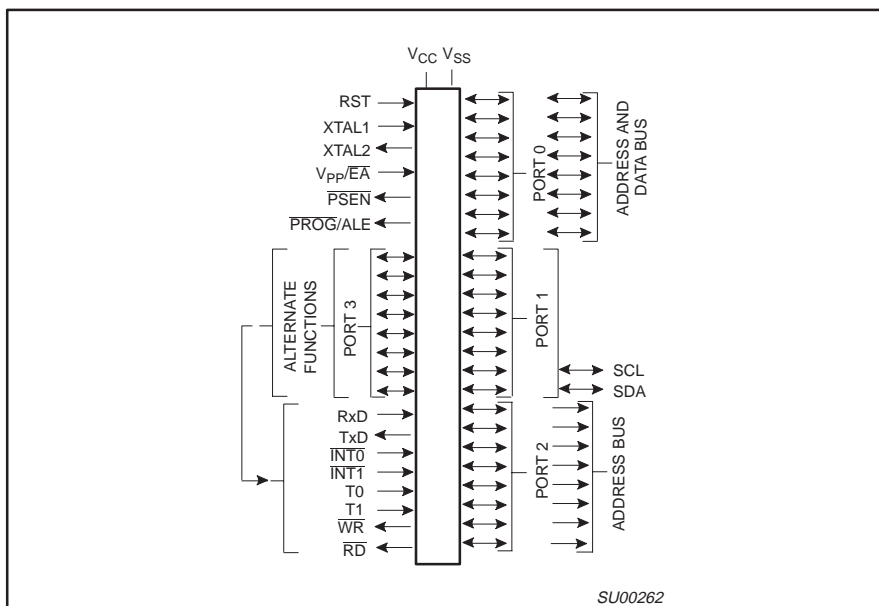

# 80C51 8-bit microcontroller 8K/16K, 256 OTP, I<sup>2</sup>C

87C652/87C654

## PLASTIC LEADED CHIP CARRIER PIN FUNCTIONS

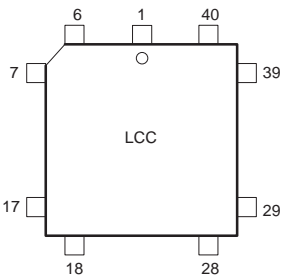

Pin	Function	Pin	Function
1	NC*	23	NC*
2	P1.0	24	P2.0/A8
3	P1.1	25	P2.1/A9
4	P1.2	26	P2.2/A10
5	P1.3	27	P2.3/A11
6	P1.4	28	P2.4/A12
7	P1.5	29	P2.5/A13
8	P1.6/SCL	30	P2.6/A14
9	P1.7/SDA	31	P2.7/A15
10	RST	32	$\overline{\text{PSEN}}$
11	P3.0/RxD	33	ALE/ $\overline{\text{PROG}}$
12	NC*	34	NC*
13	P3.1/TxD	35	$\overline{\text{EA}}/\text{V}_{\text{PP}}$
14	P3.2/ $\overline{\text{INT0}}$	36	P0.7/AD7
15	P3.3/ $\overline{\text{INT1}}$	37	P0.6/AD6
16	P3.4/T0	38	P0.5/AD5
17	P3.5/T1	39	P0.4/AD4
18	P3.6/ $\overline{\text{WR}}$	40	P0.3/AD3
19	P3.7/ $\overline{\text{RD}}$	41	P0.2/AD2
20	XTAL2	42	P0.1/AD1
21	XTAL1	43	P0.0/AD0
22	V <sub>SS</sub>	44	V <sub>CC</sub>

\* NO INTERNAL CONNECTION

SU00260

## PLASTIC QUAD FLAT PACK PIN FUNCTIONS

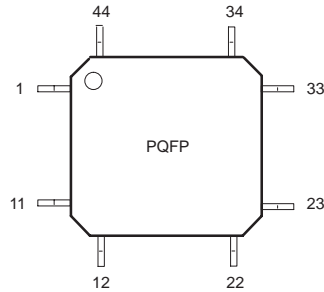

Pin	Function	Pin	Function
1	P1.5	23	P2.5/A13
2	P1.6/SCL	24	P2.6/A14
3	P1.7/SDA	25	P2.7/A15
4	RST	26	$\overline{\text{PSEN}}$
5	P3.0/RxD	27	ALE/ $\overline{\text{PROG}}$
6	NC*	28	NC*
7	P3.1/TxD	29	$\overline{\text{EA}}/\text{V}_{\text{PP}}$
8	P3.2/ $\overline{\text{INT0}}$	30	P0.7/AD7
9	P3.3/ $\overline{\text{INT1}}$	31	P0.6/AD6
10	P3.4/T0	32	P0.5/AD5
11	P3.5/T1	33	P0.4/AD4
12	P3.6/ $\overline{\text{WR}}$	34	P0.3/AD3
13	P3.7/ $\overline{\text{RD}}$	35	P0.2/AD2
14	XTAL2	36	P0.1/AD1
15	XTAL1	37	P0.0/AD0
16	V <sub>SS</sub>	38	V <sub>CC</sub>
17	NC*	39	NC*
18	P2.0/A8	40	P1.0
19	P2.1/A9	41	P1.1
20	P2.2/A10	42	P1.2
21	P2.3/A11	43	P1.3
22	P2.4/A12	44	P1.4

\* NO INTERNAL CONNECTION

SU00261

# 80C51 8-bit microcontroller

## 8K/16K, 256 OTP, I<sup>2</sup>C

87C652/87C654

### PIN DESCRIPTIONS

MNEMONIC	PIN NUMBER			TYPE	NAME AND FUNCTION
	DIP	LCC	QFP		
V <sub>SS</sub>	20	22	16	I	<b>Ground:</b> 0 V reference.
V <sub>CC</sub>	40	44	38	I	<b>Power Supply:</b> This is the power supply voltage for normal, idle, and power-down operation.
P0.0–P0.7	39–32	43–36	37–30	I/O	<b>Port 0:</b> Port 0 is an open-drain, bidirectional I/O port. Port 0 pins that have 1s written to them float and can be used as high-impedance inputs. Port 0 is also the multiplexed low-order address and data bus during accesses to external program and data memory. In this application, it uses strong internal pull-ups when emitting 1s. Port 0 also outputs the code bytes during program verification in the 87C654. External pull-ups are required during program verification.
P1.0–P1.7	1–8	2–9	40–44, 1–3	I/O	<b>Port 1:</b> Port 1 is an 8-bit bidirectional I/O port with internal pull-ups, except P1.6 and P1.7 which are open drain. Port 1 pins that have 1s written to them are pulled high by the internal pull-ups and can be used as inputs. As inputs, port 1 pins that are externally pulled low will source current because of the internal pull-ups. (See DC Electrical Characteristics: I <sub>IL</sub> ). Port 1 also receives the low-order address byte during program memory verification. Alternate functions include:
P1.6	7	8	2	I/O	<b>SCL:</b> I <sup>2</sup> C-bus serial port clock line.
P1.7	8	9	3	I/O	<b>SDA:</b> I <sup>2</sup> C-bus serial port data line.
P2.0–P2.7	21–28	24–31	18–25	I/O	<b>Port 2:</b> Port 2 is an 8-bit bidirectional I/O port with internal pull-ups. Port 2 pins that have 1s written to them are pulled high by the internal pull-ups and can be used as inputs. As inputs, port 2 pins that are externally being pulled low will source current because of the internal pull-ups. (See DC Electrical Characteristics: I <sub>IL</sub> ). Port 2 emits the high-order address byte during fetches from external program memory and during accesses to external data memory that use 16-bit addresses (MOVX @DPTR). In this application, it uses strong internal pull-ups when emitting 1s. During accesses to external data memory that use 8-bit addresses (MOV @Ri), port 2 emits the contents of the P2 special function register.
P3.0–P3.7	10–17	11, 13–19	5, 7–13	I/O	<b>Port 3:</b> Port 3 is an 8-bit bidirectional I/O port with internal pull-ups. Port 3 pins that have 1s written to them are pulled high by the internal pull-ups and can be used as inputs. As inputs, port 3 pins that are externally being pulled low will source current because of the pull-ups. (See DC Electrical Characteristics: I <sub>IL</sub> ). Port 3 also serves the special features of the 80C51 family, as listed below:
	10	11	5	I	<b>RxD (P3.0):</b> Serial input port
	11	13	7	O	<b>TxD (P3.1):</b> Serial output port
	12	14	8	I	<b>INT0 (P3.2):</b> External interrupt
	13	15	9	I	<b>INT1 (P3.3):</b> External interrupt
	14	16	10	I	<b>T0 (P3.4):</b> Timer 0 external input
	15	17	11	I	<b>T1 (P3.5):</b> Timer 1 external input
	16	18	12	O	<b>WR (P3.6):</b> External data memory write strobe
	17	19	13	O	<b>RD (P3.7):</b> External data memory read strobe
RST	9	10	4	I	<b>Reset:</b> A high on this pin for two machine cycles while the oscillator is running, resets the device. An internal diffused resistor to V <sub>SS</sub> permits a power-on reset using only an external capacitor to V <sub>CC</sub> .
ALE/PROG	30	33	27	I/O	<b>Address Latch Enable/Program Pulse:</b> Output pulse for latching the low byte of the address during an access to external memory. In normal operation, ALE is emitted at a constant rate of 1/6 the oscillator frequency, and can be used for external timing or clocking. Note that one ALE pulse is skipped during each access to external data memory. This pin is also the program pulse input (PROG) during EPROM programming.
PSEN	29	32	26	O	<b>Program Store Enable:</b> The read strobe to external program memory. When the 87C654 is executing code from the external program memory, PSEN is activated twice each machine cycle, except that two PSEN activations are skipped during each access to external data memory. PSEN is not activated during fetches from internal program memory.
E <sub>A</sub> /V <sub>PP</sub>	31	35	29	I	<b>External Access Enable/Programming Supply Voltage:</b> E <sub>A</sub> must be externally held low to enable the device to fetch code from external program memory locations 0000H and 1FFFH for 87C652 and 3FFFH for 87C654. If E <sub>A</sub> is held high, the device executes from internal program memory unless the program counter contains an address greater than 3FFFH. This pin also receives the 12.75 V programming supply voltage (V <sub>PP</sub> ) during EPROM programming.
XTAL1	19	21	15	I	<b>Crystal 1:</b> Input to the inverting oscillator amplifier and input to the internal clock generator circuits.
XTAL2	18	20	14	O	<b>Crystal 2:</b> Output from the inverting oscillator amplifier.

#### NOTE:

To avoid "latch-up" effect at power-on, the voltage on any pin at any time must not be higher than V<sub>CC</sub> + 0.5 V or V<sub>SS</sub> – 0.5 V, respectively.

80C51 8-bit microcontroller  
8K/16K, 256 OTP, I<sup>2</sup>C

87C652/87C654

**Table 1. 8XC652/654 Special Function Registers**

SYMBOL	DESCRIPTION	DIRECT ADDRESS	BIT ADDRESS, SYMBOL, OR ALTERNATIVE PORT FUNCTION								RESET VALUE
			MSB				LSB				
ACC*	Accumulator	E0H	E7	E6	E5	E4	E3	E2	E1	E0	00H
B*	B register	F0H	F7	F6	F5	F4	F3	F2	F1	F0	00H
DPTR:	Data pointer (2 bytes)										
DPH	Data pointer high	83H									00H
DPL	Data pointer low	82H									00H
			AF	AE	AD	AC	AB	AA	A9	A8	
IE*#	Interrupt enable	A8H	EA		ES1	ES0	ET1	EX1	ET0	EX0	0x000000B
			BF	BE	BD	BC	BB	BA	B9	B8	
IP*#	Interrupt priority	B8H	—		PS1	PS0	PT1	PX1	PT0	PX0	xx000000B
			87	86	85	84	83	82	81	80	
P0*	Port 0	80H	AD7	AD6	AD5	AD4	AD3	AD2	AD1	AD0	FFH
			97	96	95	94	93	92	91	90	
P1*#	Port 1	90H	SDA	SCL							FFH
			A7	A6	A5	A4	A3	A2	A1	A0	
P2*	Port 2	A0H	A15	A14	A13	A12	A11	A10	A9	A8	FFH
			B7	B6	B5	B4	B3	B2	B1	B0	
P3*	Port 3	B0H	R $\bar{D}$	WR	T1	T0	INT1	INT $\bar{0}$	TXD	RXD	FFH
PCON#	Power control	87H	SMOD	—	—	—	GF1	GF0	PD	IDL	0xxx0000B
			9F	9E	9D	9C	9B	9A	99	98	
S0CON*#	Serial 0 port control	98H	SM0	SM1	SM2	REN	TB8	RB8	TI	RI	00H
S0BUF#	Serial 0 data buffer	99H									xxxxxxxB
			D7	D6	D5	D4	D3	D2	D1	D0	
PSW*	Program status word	D0H	CY	AC	F0	RS1	RS0	OV	F1	P	00H
S1DAT#	Serial 1 data	DAH									00H
SP	Stack pointer	81H									07H
S1ADR#	Serial 1 address	DBH	SLAVE ADDRESS							GC	00H
S1STA#	Serial 1 status	D9H	SC4	SC3	SC2	SC1	SC0	0	0	0	F8H
			DF	DE	DD	DC	DB	DA	D9	D8	
S1CON*#	Serial 1 control	D8H	CR2	ENS1	STA	STO	SI	AA	CR1	CR0	00000000B
			8F	8E	8D	8C	8B	8A	89	88	
TCON*	Timer control	88H	TF1	TR1	TF0	TR0	IE1	IT1	IE0	IT0	00H
TH1	Timer high 1	8DH									00H
TH0	Timer high 0	8CH									00H
TL1	Timer low 1	8BH									00H
TL0	Timer low 0	8AH									00H
TMOD	Timer mode	89H	GATE	C $\bar{T}$	M1	M0	GATE	C $\bar{T}$	M1	M0	00H

\* SFRs are bit addressable.

# SFRs are modified from or added to the 80C51 SFRs.

# 80C51 8-bit microcontroller 8K/16K, 256 OTP, I<sup>2</sup>C

87C652/87C654

## OSCILLATOR CHARACTERISTICS

XTAL1 and XTAL2 are the input and output, respectively, of an inverting amplifier. The pins can be configured for use as an on-chip oscillator, as shown in the Logic Symbol.

To drive the device from an external clock source, XTAL1 should be driven while XTAL2 is left unconnected. There are no requirements on the duty cycle of the external clock signal, because the input to the internal clock circuitry is through a divide-by-two flip-flop. However, minimum and maximum high and low times specified in the data sheet must be observed.

### Reset

A reset is accomplished by holding the RST pin high for at least two machine cycles (24 oscillator periods), while the oscillator is running. To insure a good power-on reset, the RST pin must be high long enough to allow the oscillator time to start up (normally a few

milliseconds) plus two machine cycles. At power-on, the voltage on V<sub>CC</sub> and RST must come up at the same time for a proper start-up.

### Idle Mode

In the idle mode, the CPU puts itself to sleep while all of the on-chip peripherals stay active. The instruction to invoke the idle mode is the last instruction executed in the normal operating mode before the idle mode is activated. The CPU contents, the on-chip RAM, and all of the special function registers remain intact during this mode. The idle mode can be terminated either by any enabled interrupt (at which time the process is picked up at the interrupt service routine and continued), or by a hardware reset which starts the processor in the same manner as a power-on reset.

### Power-Down Mode

In the power-down mode, the oscillator is stopped and the instruction to invoke

power-down is the last instruction executed. Only the contents of the on-chip RAM are preserved. A hardware reset is the only way to terminate the power-down mode. The control bits for the reduced power modes are in the special function register PCON. Table 2 shows the state of the I/O ports during low current operating modes.

## I<sup>2</sup>C SERIAL COMMUNICATION—SIO1

The I<sup>2</sup>C serial port is identical to the I<sup>2</sup>C serial port on the 8XC552. The operation of this subsystem is described in detail in the 8XC552 section of this manual.

Note that in both the 8XC652/4 and the 8XC552 the I<sup>2</sup>C pins are alternate functions to port pins P1.6 and P1.7. Because of this, P1.6 and P1.7 on these parts do not have a pull-up structure as found on the 80C51. Therefore P1.6 and P1.7 have open drain outputs on the 8XC652/4.

**Table 2. External Pin Status During Idle and Power-Down Mode**

MODE	PROGRAM MEMORY	ALE	PSEN	PORT 0	PORT 1	PORT 2	PORT 3
Idle	Internal	1	1	Data	Data	Data	Data
Idle	External	1	1	Float	Data	Address	Data
Power-down	Internal	0	0	Data	Data	Data	Data
Power-down	External	0	0	Float	Data	Data	Data

## Serial Control Register (S1CON) – See Table 3

### S1CON (D8H)

CR2	ENS1	STA	STO	SI	AA	CR1	CR0
-----	------	-----	-----	----	----	-----	-----

Bits CR0, CR1 and CR2 determine the serial clock frequency that is generated in the master mode of operation.

**Table 3. Serial Clock Rates**

CR2	CR1	CR0	BIT FREQUENCY (kHz) AT f <sub>OSC</sub>				f <sub>OSC</sub> DIVIDED BY
			6 MHz	12 MHz	16 MHz	20 MHz	
0	0	0	23	47	62.5	78	256
0	0	1	27	54	71	89 <sup>1</sup>	224
0	1	0	31.25	62.5	83.3	104 <sup>1</sup>	192
0	1	1	37	75	100	125 <sup>1</sup>	160
1	0	0	6.25	12.5	17	21	960
1	0	1	50	100	133 <sup>1</sup>	166 <sup>1</sup>	120
1	1	0	100	200 <sup>1</sup>	267 <sup>1</sup>	334 <sup>1</sup>	60
1	1	1	0.25 < 62.5 0 to 255	0.5 < 62.5 0 to 254	0.65 < 55.6 0 to 253	0.81 < 69.4 0 to 253	96 × (256 – (reload value Timer 1)) (Reload value range: 0 – 254 in mode 2)

### NOTE:

1. These frequencies exceed the upper limit of 100kHz of the I<sup>2</sup>C-bus specification and cannot be used in an I<sup>2</sup>C-bus application.

# 80C51 8-bit microcontroller

## 8K/16K, 256 OTP, I<sup>2</sup>C

87C652/87C654

### ABSOLUTE MAXIMUM RATINGS<sup>1, 2, 3</sup>

PARAMETER	RATING	UNIT
Storage temperature range	-65 to +150	°C
Voltage on $\overline{E\bar{A}}/V_{PP}$ to $V_{SS}$	-0.5 to + 13	V
Voltage on any other pin to $V_{SS}$	-0.5 to + 6.5	V
Input, output current on any single pin	±5	mA
Power dissipation (based on package heat transfer limitations, not device power consumption)	1	W

#### NOTES:

- Stresses above those listed under Absolute Maximum Ratings may cause permanent damage to the device. This is a stress rating only and functional operation of the device at these or any conditions other than those described in the AC and DC Electrical Characteristics section of this specification is not implied.
- This product includes circuitry specifically designed for the protection of its internal devices from the damaging effects of excessive static charge. Nonetheless, it is suggested that conventional precautions be taken to avoid applying greater than the rated maxima.
- Parameters are valid over operating temperature range unless otherwise specified. All voltages are with respect to  $V_{SS}$  unless otherwise noted.

### DEVICE SPECIFICATIONS

TYPE	SUPPLY VOLTAGE (V)		FREQUENCY (MHz)		TEMPERATURE RANGE (°C)
	MIN.	MAX.	MIN.	MAX.	
S87C652-4 and S87C654-4	4.5	5.5	3.5	16	0 to +70
S87C652-5 and S87C654-5	4.5	5.5	3.5	16	-40 to +85
S87C654-7	4.5	5.5	3.5	20	0 to +70



# 80C51 8-bit microcontroller

## 8K/16K, 256 OTP, I<sup>2</sup>C

87C652/87C654

### DC ELECTRICAL CHARACTERISTICS

V<sub>SS</sub> = 0 V

SYMBOL	PARAMETER	PART TYPE	TEST CONDITIONS	LIMITS		UNIT
				MIN.	MAX.	
V <sub>IL</sub>	Input low voltage, except EA, P1.6/SCL, P1.7/SDA	0 to +70°C -40 to +85°C		-0.5 -0.5	0.2V <sub>CC</sub> -0.1 0.2V <sub>CC</sub> -0.15	V V
V <sub>IL1</sub>	Input low voltage to EA	0 to +70°C -40 to +85°C		-0.5 -0.5	0.2V <sub>CC</sub> -0.3 0.2V <sub>CC</sub> -0.35	V V
V <sub>IL2</sub>	Input low voltage to P1.6/SCL, P1.7/SDA <sup>1</sup>			-0.5	0.3V <sub>CC</sub>	V
V <sub>IH</sub>	Input high voltage, except XTAL1, RST, P1.6/SCL, P1.7/SDA	0 to +70°C -40 to +85°C		0.2V <sub>CC</sub> +0.9 0.2V <sub>CC</sub> +1.0	V <sub>CC</sub> +0.5 V <sub>CC</sub> +0.5	V V
V <sub>IH1</sub>	Input high voltage, XTAL1, RST	0 to +70°C -40 to +85°C		0.7V <sub>CC</sub> 0.7V <sub>CC</sub> +0.1	V <sub>CC</sub> +0.5 V <sub>CC</sub> +0.5	V V
V <sub>IH2</sub>	Input high voltage, P1.6/SCL, P1.7/SDA <sup>1</sup>			0.7V <sub>CC</sub>	6.0	V
V <sub>OL</sub>	Output low voltage, ports 1, 2, 3, except P1.6/SCL, P1.7/SDA		I <sub>OL</sub> = 1.6mA <sup>2, 3</sup>		0.45	V
V <sub>OL1</sub>	Output low voltage, port 0, ALE, PSEN		I <sub>OL</sub> = 3.2mA <sup>2, 3</sup>		0.45	V
V <sub>OL2</sub>	Output low voltage, P1.6/SCL, P1.7/SDA		I <sub>OL</sub> = 3.0mA		0.4	V
V <sub>OH</sub>	Output high voltage, ports 1, 2, 3	0 to +70°C -40 to +85°C	I <sub>OH</sub> = -60μA I <sub>OH</sub> = -25μA	2.4 0.75V <sub>CC</sub>		V V
V <sub>OH1</sub>	Output high voltage; port 0 in external bus mode, ALE, PSEN, RST <sup>4</sup>	0 to +70°C -40 to +85°C	I <sub>OH</sub> = -400μA I <sub>OH</sub> = -150μA	2.4 0.75V <sub>CC</sub>		V V
I <sub>IL</sub>	Logical 0 input current, ports 1, 2, 3, 4, except P1.6/SCL, P1.7/SDA	0 to +70°C -40 to +85°C	V <sub>IN</sub> = 0.45V		-50 -75	μA μA
I <sub>TL</sub>	Logical 1-to-0 transition current, ports 1, 2, 3, except P1.6/SCL, P1.7/SDA	0 to +70°C -40 to +85°C	See note 5		-650 -750	μA μA
I <sub>L1</sub>	Input leakage current, port 0		0.45V < V <sub>I</sub> < V <sub>CC</sub>		±10	μA
I <sub>L2</sub>	Input leakage current, P1.6/SCL, P1.7/SDA		0V < V <sub>I</sub> < 6.0V 0V < V <sub>CC</sub> < 6.0V		±10	μA μA
I <sub>CC</sub>	Power supply current:  Active mode @ 16 MHz <sup>7</sup> Idle mode @ 16 MHz <sup>8</sup> Power down mode <sup>9, 10</sup> Power down mode <sup>9, 10</sup>	0 to +70°C -40 to +85°C	See note 6 V <sub>CC</sub> =6.0V		25 6 50 135	mA mA μA μA
R <sub>RST</sub>	Internal reset pull-down resistor			50	150	kΩ
C <sub>IO</sub>	Pin capacitance		Freq.=1 MHz		10	pF

#### NOTES:

- The input threshold voltage of P1.6 and P1.7 (SIO1) meets the I<sup>2</sup>C specification, so an input voltage below 0.3V<sub>CC</sub> will be recognized as a logic 0 while an input voltage above 0.7V<sub>CC</sub> will be recognized as a logic 1.
- Capacitive loading on ports 0 and 2 may cause spurious noise to be superimposed on the V<sub>OL</sub>s of ALE and ports 1 and 3. The noise is due to external bus capacitance discharging into the port 0 and port 2 pins when these pins make 1-to-0 transitions during bus operations. In the worst cases (capacitive loading > 100 pF), the noise pulse on the ALE pin may exceed 0.8 V. In such cases, it may be desirable to qualify ALE with a Schmitt Trigger, or use an address latch with a Schmitt Trigger STROBE input. I<sub>OL</sub> can exceed these conditions provided that no single output sinks more than 5 mA and no more than two outputs exceed the test conditions.
- Under steady state (non-transient) conditions, I<sub>OL</sub> must be externally limited as follows: Maximum I<sub>OL</sub> = 10 mA per port pin; Maximum I<sub>OL</sub> = 26 mA total for Port 0; Maximum I<sub>OL</sub> = 15 mA total for Ports 1, 2, and 3; Maximum I<sub>OL</sub> = 71 mA total for all output pins. If I<sub>OL</sub> exceeds the test conditions, V<sub>OL</sub> may exceed the related specification. Pins are not guaranteed to sink current greater than the listed test conditions.
- Capacitive loading on ports 0 and 2 may cause the V<sub>OH</sub> on ALE and PSEN to momentarily fall below the 0.9V<sub>CC</sub> specification when the address bits are stabilizing.
- Pins of ports 1, 2, and 3 source a transition current when they are being externally driven from 1 to 0. The transition current reaches its maximum value when V<sub>IN</sub> is approximately 2 V.
- See Figures 9 through 11 for I<sub>CC</sub> test conditions.
- The operating supply current is measured with all output pins disconnected; XTAL1 driven with t<sub>r</sub> = t<sub>f</sub> = 10ns; V<sub>IL</sub> = V<sub>SS</sub> + 0.5 V; V<sub>IH</sub> = V<sub>CC</sub> - 0.5 V; XTAL2 not connected; EA = RST = Port 0 = P1.6 = P1.7 = V<sub>CC</sub>; f<sub>CLK</sub> = 16 MHz. See Figure 9.
- The idle mode supply current is measured with all output pins disconnected; XTAL1 driven with t<sub>r</sub> = t<sub>f</sub> = 10 ns; V<sub>IL</sub> = V<sub>SS</sub> + 0.5 V; V<sub>IH</sub> = V<sub>CC</sub> - 0.5 V; XTAL2 not connected; Port 0 = P1.6 = P1.7 = V<sub>CC</sub>; EA = RST = V<sub>SS</sub>; f<sub>CLK</sub> = 16 MHz. See Figure 10.
- The power-down current is measured with all output pins disconnected; XTAL2 not connected; Port 0 = P1.6 = P1.7 = V<sub>CC</sub>; EA = RST = V<sub>SS</sub>. See Figure 11.
- 0.2V ≤ V<sub>PD</sub> ≤ V<sub>CCmax</sub>.

# 80C51 8-bit microcontroller

## 8K/16K, 256 OTP, I<sup>2</sup>C

87C652/87C654

### AC ELECTRICAL CHARACTERISTICS<sup>1, 2</sup>

SYMBOL	FIGURE	PARAMETER	16 MHz CLOCK		VARIABLE CLOCK		UNIT
			MIN	MAX	MIN	MAX	
1/t <sub>CLCL</sub>	2	Oscillator frequency <b>Speed Versions</b> 87C654 -4, -5			3.5	16	MHz
t <sub>LHLL</sub>	2	ALE pulse width	85		2t <sub>CLCL</sub> -40		ns
t <sub>AVLL</sub>	2	Address valid to ALE low	8		t <sub>CLCL</sub> -55		ns
t <sub>LLAX</sub>	2	Address hold after ALE low	28		t <sub>CLCL</sub> -35		ns
t <sub>LLIV</sub>	2	ALE low to valid instruction in		150		4t <sub>CLCL</sub> -100	ns
t <sub>LLPL</sub>	2	ALE low to PSEN low	23		t <sub>CLCL</sub> -40		ns
t <sub>PLPH</sub>	2	PSEN pulse width	143		3t <sub>CLCL</sub> -45		ns
t <sub>PLIV</sub>	2	PSEN low to valid instruction in		83		3t <sub>CLCL</sub> -105	ns
t <sub>PXIX</sub>	2	Input instruction hold after PSEN	0		0		ns
t <sub>PXIZ</sub>	2	Input instruction float after PSEN		38		t <sub>CLCL</sub> -25	ns
t <sub>AVIV</sub>	2	Address to valid instruction in		208		5t <sub>CLCL</sub> -105	ns
t <sub>PLAZ</sub>	2	PSEN low to address float		10		10	ns
<b>Data Memory</b>							
t <sub>AVLL</sub>	3, 4	Address valid to ALE low	28		t <sub>CLCL</sub> -35		ns
t <sub>RLRH</sub>	3, 4	R <sub>D</sub> pulse width	275		6t <sub>CLCL</sub> -100		ns
t <sub>WLWH</sub>	3, 4	W <sub>R</sub> pulse width	275		6t <sub>CLCL</sub> -100		ns
t <sub>RLDV</sub>	3, 4	R <sub>D</sub> low to valid data in		148		5t <sub>CLCL</sub> -165	ns
t <sub>RHDX</sub>	3, 4	Data hold after R <sub>D</sub>	0		0		ns
t <sub>RHDZ</sub>	3, 4	Data float after R <sub>D</sub>		55		2t <sub>CLCL</sub> -70	ns
t <sub>LLDV</sub>	3, 4	ALE low to valid data in		350		8t <sub>CLCL</sub> -150	ns
t <sub>AVDV</sub>	3, 4	Address to valid data in		398		9t <sub>CLCL</sub> -165	ns
t <sub>LLWL</sub>	3, 4	ALE low to R <sub>D</sub> or W <sub>R</sub> low	138	238	3t <sub>CLCL</sub> -50	3t <sub>CLCL</sub> +50	ns
t <sub>AVWL</sub>	3, 4	Address valid to W <sub>R</sub> low or R <sub>D</sub> low	120		4t <sub>CLCL</sub> -130		ns
t <sub>QVWX</sub>	3, 4	Data valid to W <sub>R</sub> transition	3		t <sub>CLCL</sub> -60		ns
t <sub>DW</sub>	3, 4	Data setup time before W <sub>R</sub>	288		7t <sub>CLCL</sub> -150		ns
t <sub>WHQX</sub>	3, 4	Data hold after W <sub>R</sub>	13		t <sub>CLCL</sub> -50		ns
t <sub>RLAZ</sub>	3, 4	R <sub>D</sub> low to address float		0		0	ns
t <sub>WHLH</sub>	3, 4	R <sub>D</sub> or W <sub>R</sub> high to ALE high	23	103	t <sub>CLCL</sub> -40	t <sub>CLCL</sub> +40	ns
<b>Shift Register</b>							
t <sub>XLXL</sub>	5	Serial port clock cycle time <sup>3</sup>	0.75		12t <sub>CLCL</sub>		μs
t <sub>QVXH</sub>	5	Output data setup to clock rising edge <sup>3</sup>	492		10t <sub>CLCL</sub> -133		ns
t <sub>XHQX</sub>	5	Output data hold after clock rising edge <sup>3</sup>	80		2t <sub>CLCL</sub> -117		ns
t <sub>XHDX</sub>	5	Input data hold after clock rising edge <sup>3</sup>	0		0		ns
t <sub>XHDV</sub>	5	Clock rising edge to input data valid <sup>3</sup>		492		10t <sub>CLCL</sub> -133	ns
<b>External Clock</b>							
t <sub>CHCX</sub>	6	High time <sup>3</sup>	20		20	t <sub>CLCL</sub> - t <sub>LOW</sub>	ns
t <sub>CLCX</sub>	6	Low time <sup>3</sup>	20		20	t <sub>CLCL</sub> - t <sub>HIGH</sub>	ns
t <sub>CLCH</sub>	6	Rise time <sup>3</sup>		20		20	ns
t <sub>CHCL</sub>	6	Fall time <sup>3</sup>		20		20	ns

#### NOTES:

- Parameters are valid over operating temperature range unless otherwise specified.
- Load capacitance for port 0, ALE, and PSEN = 100 pF, load capacitance for all other outputs = 80 pF.
- These values are characterized but not 100% production tested.

# 80C51 8-bit microcontroller

## 8K/16K, 256 OTP, I<sup>2</sup>C

87C652/87C654

### AC ELECTRICAL CHARACTERISTICS<sup>1, 2</sup>

SYMBOL	FIGURE	PARAMETER	20 MHz CLOCK		VARIABLE CLOCK		UNIT
			MIN	MAX	MIN	MAX	
1/t <sub>CLCL</sub>	2	Oscillator frequency: <b>Speed Versions 87C654</b> -7, -8			3.5	20	MHz
t <sub>LHLL</sub>	2	ALE pulse width	60		2t <sub>CLCL</sub> -40		ns
t <sub>AVLL</sub>	2	Address valid to ALE low	25		t <sub>CLCL</sub> -25		ns
t <sub>LLAX</sub>	2	Address hold after ALE low	25		t <sub>CLCL</sub> -25		ns
t <sub>LLIV</sub>	2	ALE low to valid instruction in		135		4t <sub>CLCL</sub> -65	ns
t <sub>LLPL</sub>	2	ALE low to PSEN low	25		t <sub>CLCL</sub> -25		ns
t <sub>PLPH</sub>	2	PSEN pulse width	105		3t <sub>CLCL</sub> -45		ns
t <sub>PLIV</sub>	2	PSEN low to valid instruction in		90		3t <sub>CLCL</sub> -60	ns
t <sub>PXIX</sub>	2	Input instruction hold after PSEN	0		0		ns
t <sub>PXIZ</sub>	2	Input instruction float after PSEN		25		t <sub>CLCL</sub> -25	ns
t <sub>AVIV</sub>	2	Address to valid instruction in		170		5t <sub>CLCL</sub> -80	ns
t <sub>PLAZ</sub>	2	PSEN low to address float		10		10	ns
<b>Data Memory</b>							
t <sub>AVLL</sub>	3, 4	Address valid to ALE low	25		t <sub>CLCL</sub> -25		ns
t <sub>RLRH</sub>	3, 4	R <sub>D</sub> pulse width	200		6t <sub>CLCL</sub> -100		ns
t <sub>WLWH</sub>	3, 4	W <sub>R</sub> pulse width	200		6t <sub>CLCL</sub> -100		ns
t <sub>RLDV</sub>	3, 4	R <sub>D</sub> low to valid data in		160		5t <sub>CLCL</sub> -90	ns
t <sub>RHDX</sub>	3, 4	Data hold after R <sub>D</sub>	0		0		ns
t <sub>RHDZ</sub>	3, 4	Data float after R <sub>D</sub>		72		2t <sub>CLCL</sub> -28	ns
t <sub>LLDV</sub>	3, 4	ALE low to valid data in		250		8t <sub>CLCL</sub> -150	ns
t <sub>AVDV</sub>	3, 4	Address to valid data in		285		9t <sub>CLCL</sub> -165	ns
t <sub>LLWL</sub>	3, 4	ALE low to R <sub>D</sub> or W <sub>R</sub> low	100	200	3t <sub>CLCL</sub> -50	3t <sub>CLCL</sub> +50	ns
t <sub>AVWL</sub>	3, 4	Address valid to W <sub>R</sub> low or R <sub>D</sub> low	125		4t <sub>CLCL</sub> -75		ns
t <sub>QVWX</sub>	3, 4	Data valid to W <sub>R</sub> transition	20		t <sub>CLCL</sub> -30		ns
t <sub>DW</sub>	3, 4	Data setup time before W <sub>R</sub>	220		7t <sub>CLCL</sub> -130		ns
t <sub>WHQX</sub>	3, 4	Data hold after W <sub>R</sub>	25		t <sub>CLCL</sub> -25		ns
t <sub>RLAZ</sub>	3, 4	R <sub>D</sub> low to address float		0		0	ns
t <sub>WHLH</sub>	3, 4	R <sub>D</sub> or W <sub>R</sub> high to ALE high	25	75	t <sub>CLCL</sub> -25	t <sub>CLCL</sub> +25	ns
<b>Shift Register</b>							
t <sub>XLXL</sub>	5	Serial port clock cycle time <sup>3</sup>	0.6		12t <sub>CLCL</sub>		μs
t <sub>QVXH</sub>	5	Output data setup to clock rising edge <sup>3</sup>	367		10t <sub>CLCL</sub> -133		ns
t <sub>XHQX</sub>	5	Output data hold after clock rising edge <sup>3</sup>	40		2t <sub>CLCL</sub> -60		ns
t <sub>XHDX</sub>	5	Input data hold after clock rising edge <sup>3</sup>	0		0		ns
t <sub>XHDV</sub>	5	Clock rising edge to input data valid <sup>3</sup>		367		10t <sub>CLCL</sub> -133	ns
<b>External Clock</b>							
t <sub>CHCX</sub>	6	High time <sup>3</sup>	17		17	t <sub>CLCL</sub> - t <sub>LOW</sub>	ns
t <sub>CLCX</sub>	6	Low time <sup>3</sup>	17		17	t <sub>CLCL</sub> - t <sub>HIGH</sub>	ns
t <sub>CLCH</sub>	6	Rise time <sup>3</sup>		20		20	ns
t <sub>CHCL</sub>	6	Fall time <sup>3</sup>		20		20	ns

#### NOTES:

- Parameters are valid over operating temperature range unless otherwise specified.
- Load capacitance for port 0, ALE, and PSEN = 100 pF, load capacitance for all other outputs = 80 pF.
- These values are characterized but not 100% production tested.

80C51 8-bit microcontroller  
8K/16K, 256 OTP, I<sup>2</sup>C

87C652/87C654

AC ELECTRICAL CHARACTERISTICS – I<sup>2</sup>C INTERFACE

SYMBOL	PARAMETER	INPUT	OUTPUT
<b>SCL TIMING CHARACTERISTICS</b>			
t <sub>HD; STA</sub>	START condition hold time	≥ 14 t <sub>CLCL</sub>	> 4.0 μs <sup>1</sup>
t <sub>LOW</sub>	SCL LOW time	≥ 16 t <sub>CLCL</sub>	> 4.7 μs <sup>1</sup>
t <sub>HIGH</sub>	SCL HIGH time	≥ 14 t <sub>CLCL</sub>	> 4.0 μs <sup>1</sup>
t <sub>RC</sub>	SCL rise time	≤ 1 μs	– <sup>2</sup>
t <sub>FC</sub>	SCL fall time	≤ 0.3 μs	< 0.3 μs <sup>3</sup>
<b>SDA TIMING CHARACTERISTICS</b>			
t <sub>SU; DAT1</sub>	Data set-up time	≥ 250 ns	> 20 t <sub>CLCL</sub> – t <sub>RD</sub>
t <sub>SU; DAT2</sub>	SDA set-up time (before rep. START cond.)	≥ 250 ns	> 1 μs <sup>1</sup>
t <sub>SU; DAT3</sub>	SDA set-up time (before STOP cond.)	≥ 250 ns	> 8 t <sub>CLCL</sub>
t <sub>HD; DAT</sub>	Data hold time	≥ 0 ns	> 8 t <sub>CLCL</sub> – t <sub>FC</sub>
t <sub>SU; STA</sub>	Repeated START set-up time	≥ 14 t <sub>CLCL</sub>	> 4.7 μs <sup>1</sup>
t <sub>SU; STO</sub>	STOP condition set-up time	≥ 14 t <sub>CLCL</sub>	> 4.0 μs <sup>1</sup>
t <sub>BUF</sub>	Bus free time	≥ 14 t <sub>CLCL</sub>	> 4.7 μs <sup>1</sup>
t <sub>RD</sub>	SDA rise time	≤ 1 μs	– <sup>2</sup>
t <sub>FD</sub>	SDA fall time	≤ 0.3 μs	< 0.3 μs <sup>3</sup>

NOTES:

- At 100 kbit/s. At other bit rates this value is inversely proportional to the bit-rate of 100 kbit/s.
- Determined by the external bus-line capacitance and the external bus-line pull-resistor, this must be < 1 μs.
- Spikes on the SDA and SCL lines with a duration of less than 3 t<sub>CLCL</sub> will be filtered out. Maximum capacitance on bus-lines SDA and SCL = 400 pF.
- t<sub>CLCL</sub> = 1/f<sub>OSC</sub> = one oscillator clock period at pin XTAL1. For 62 ns < t<sub>CLCL</sub> < 285 ns (16 MHz) > f<sub>OSC</sub> > 3.5 MHz) the SI01 interface meets the I<sup>2</sup>C-bus specification for bit-rates up to 100 kbit/s.

TIMING SIO1 (I<sup>2</sup>C) INTERFACE

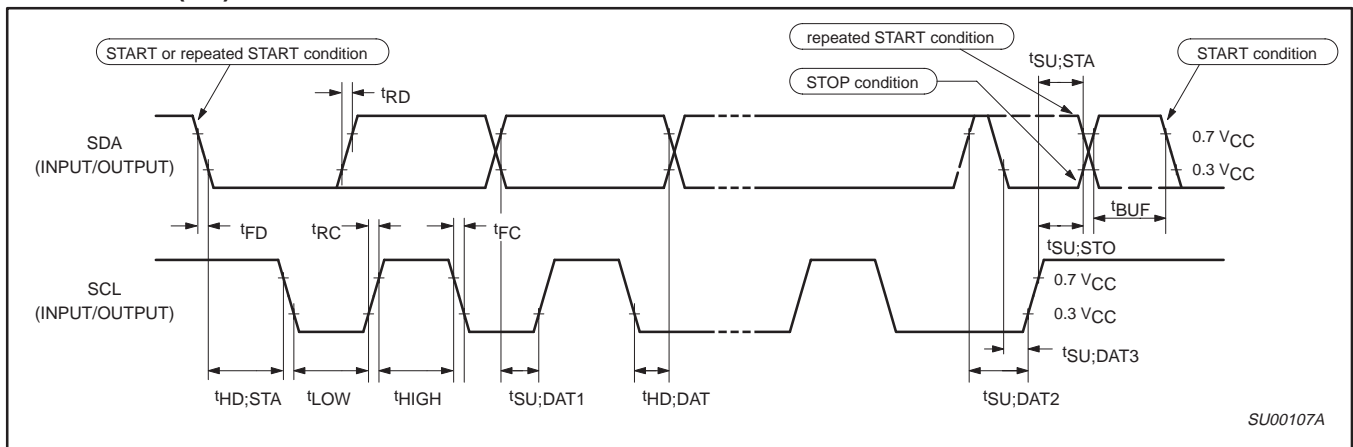

# 80C51 8-bit microcontroller 8K/16K, 256 OTP, I<sup>2</sup>C

87C652/87C654

## EXPLANATION OF THE AC SYMBOLS

Each timing symbol has five characters. The first character is always 't' (= time). The other characters, depending on their positions, indicate the name of a signal or the logical status of that signal. The designations are:

- A – Address
- C – Clock
- D – Input data
- H – Logic level high
- I – Instruction (program memory contents)
- L – Logic level low, or ALE
- P –  $\overline{\text{PSEN}}$

- Q – Output data
- R –  $\overline{\text{RD}}$  signal
- t – Time
- V – Valid
- W –  $\overline{\text{WR}}$  signal
- X – No longer a valid logic level
- Z – Float

**Examples:**  $t_{\text{AVLL}}$  = Time for address valid to ALE low.

$t_{\text{LLPL}}$  = Time for ALE low to  $\overline{\text{PSEN}}$  low.

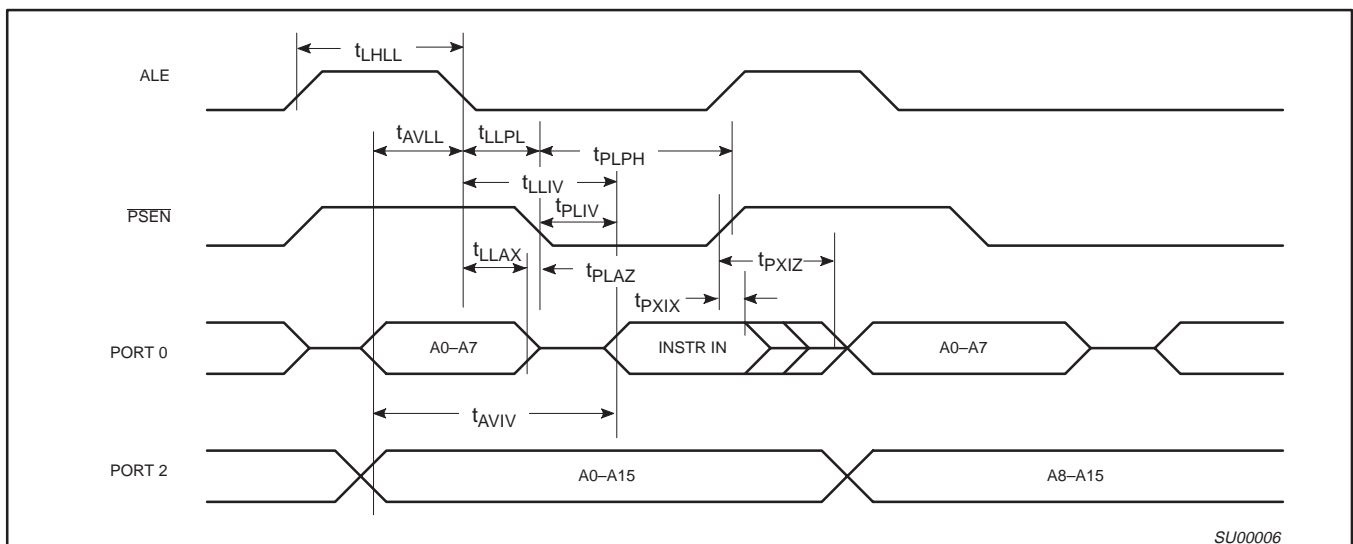

SU00006

Figure 1. External Program Memory Read Cycle

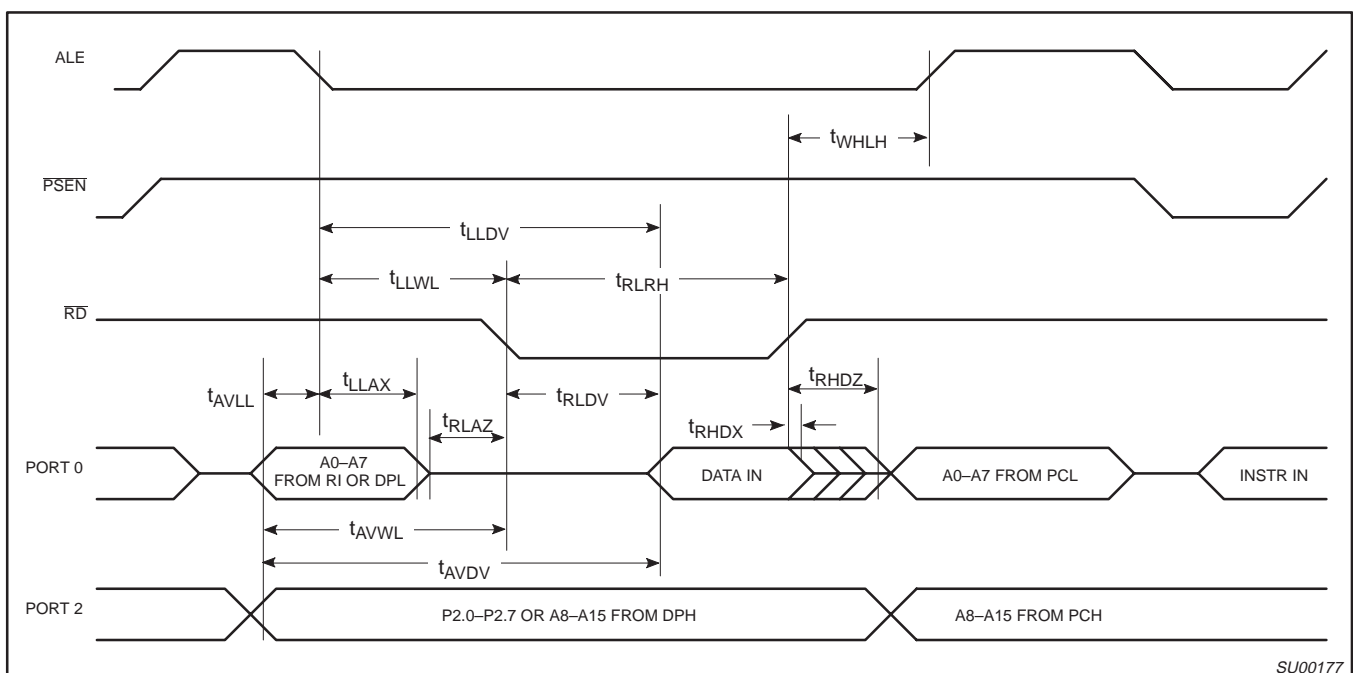

SU00177

Figure 2. External Data Memory Read Cycle

80C51 8-bit microcontroller  
8K/16K, 256 OTP, I<sup>2</sup>C

87C652/87C654

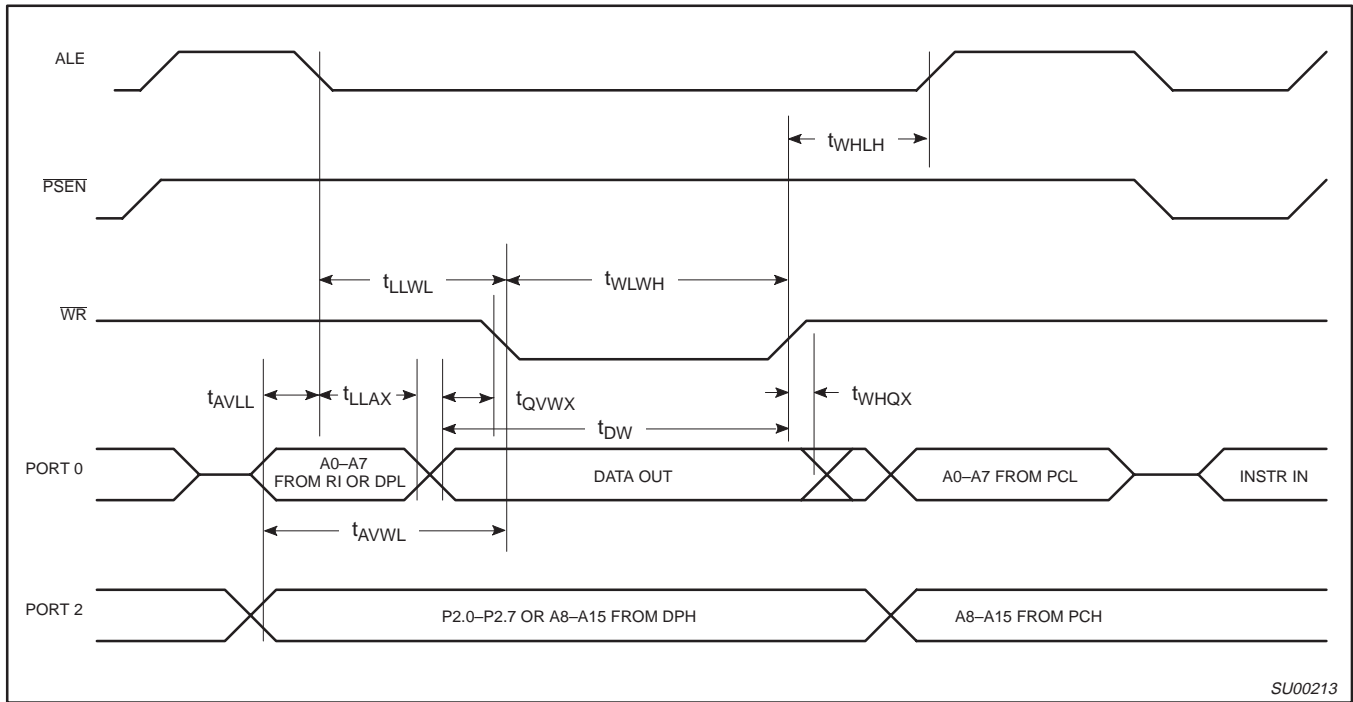

Figure 3. External Data Memory Write Cycle

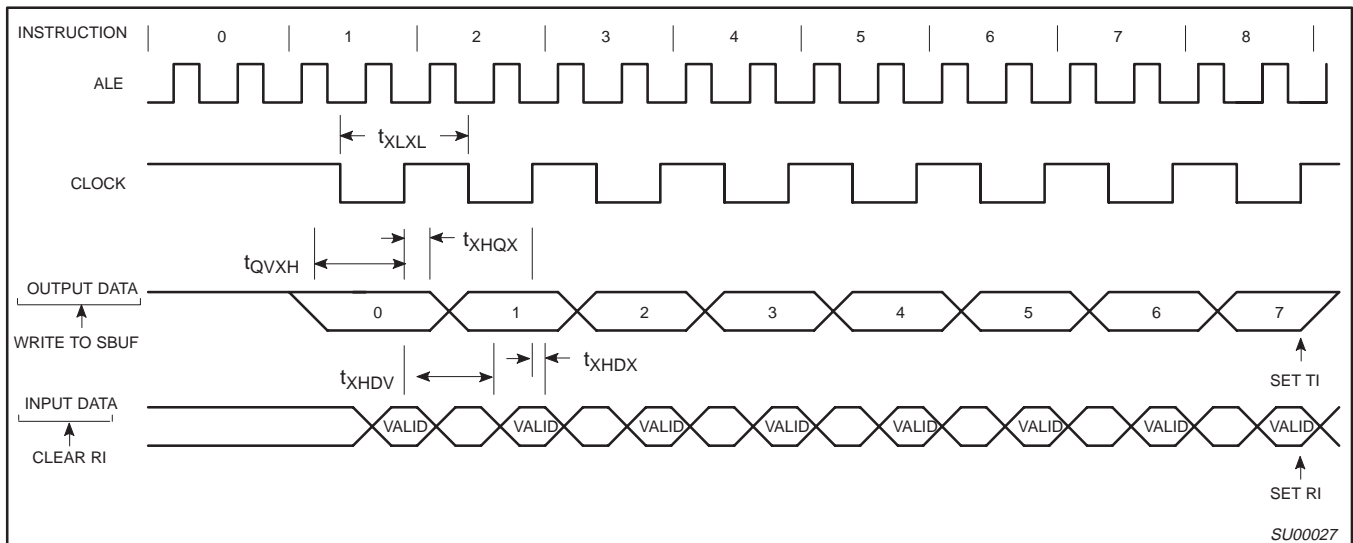

Figure 4. Shift Register Mode Timing

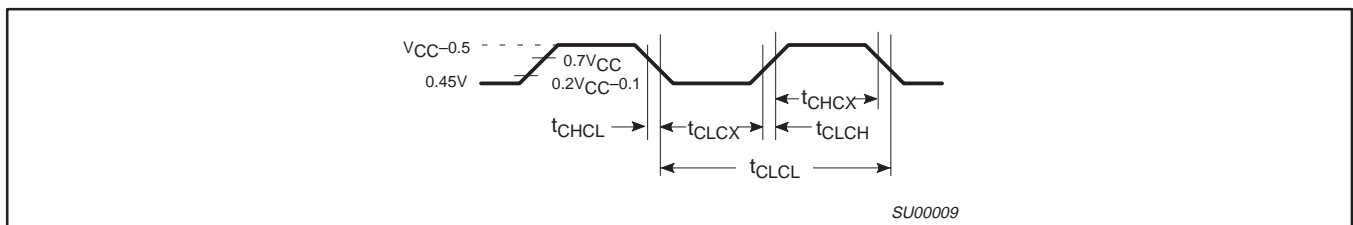

Figure 5. External Clock Drive

80C51 8-bit microcontroller  
8K/16K, 256 OTP, I<sup>2</sup>C

87C652/87C654

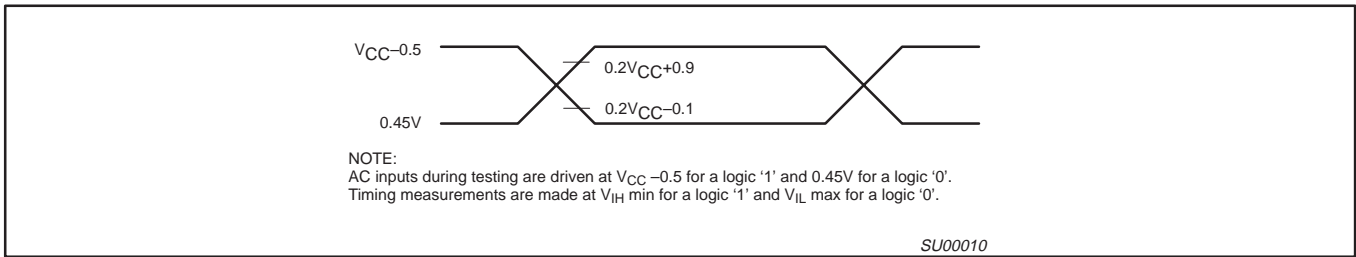

Figure 6. AC Testing Input/Output

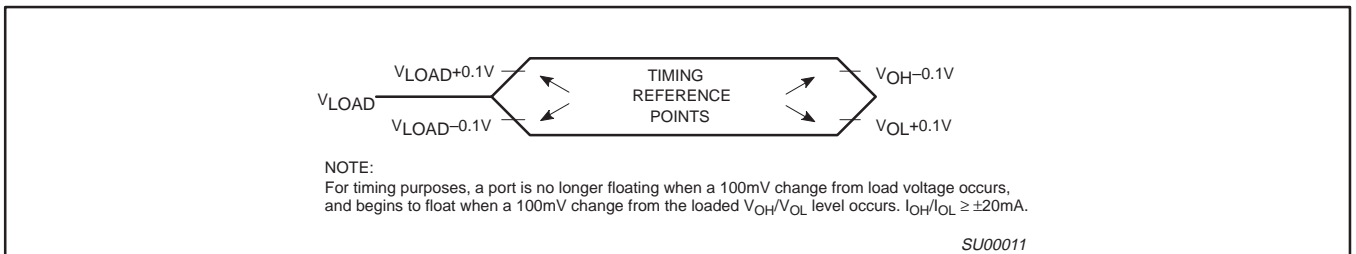

Figure 7. Float Waveform

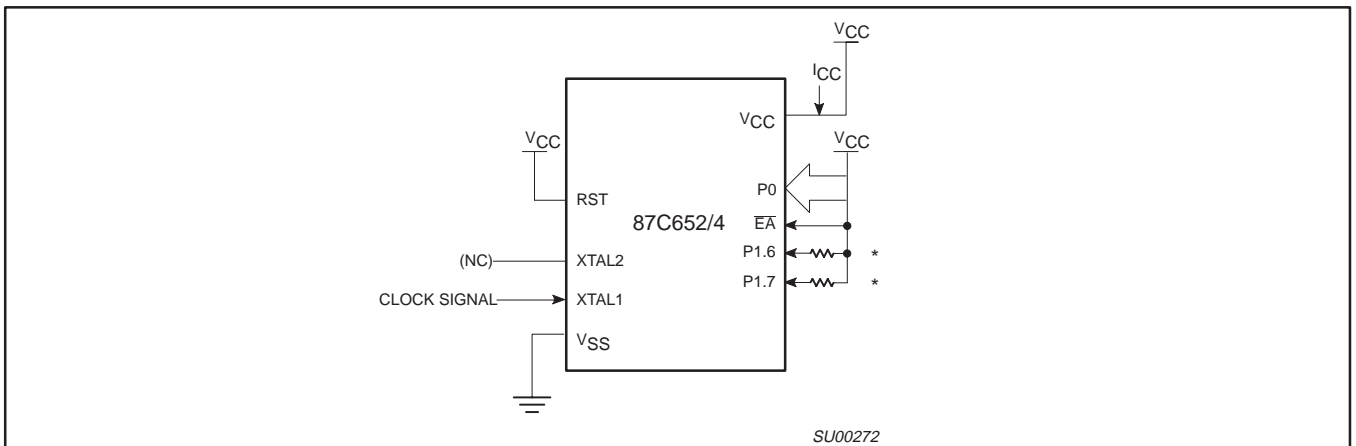

Figure 8.  $I_{CC}$  Test Condition, Active Mode  
All other pins are disconnected

NOTE:

\* Ports 1.6 and 1.7 should be connected to  $V_{CC}$  through resistors of sufficiently high value such that the sink current into these pins does not exceed the  $I_{OL1}$  specification.

80C51 8-bit microcontroller  
8K/16K, 256 OTP, I<sup>2</sup>C

87C652/87C654

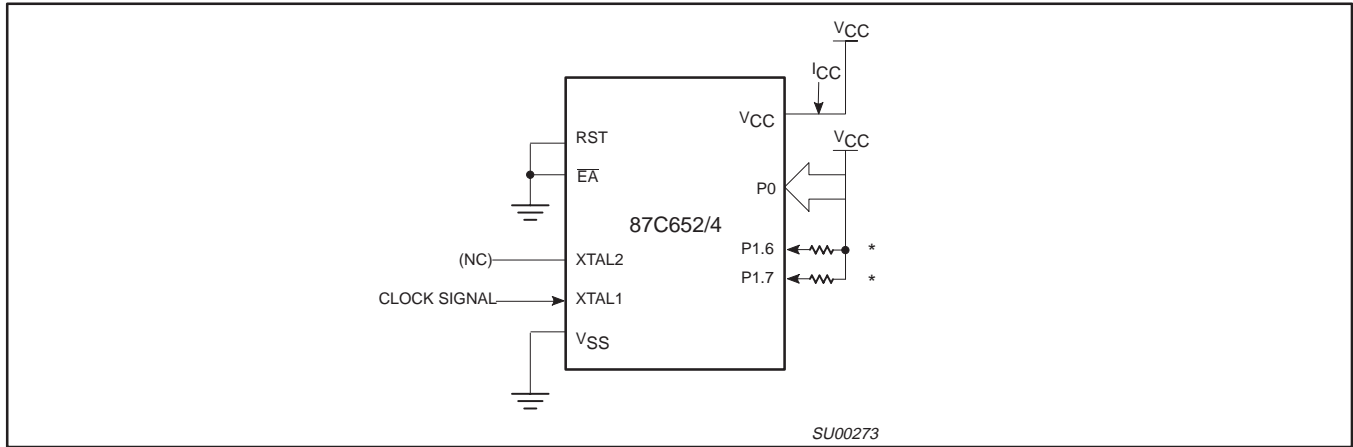

Figure 9. I<sub>CC</sub> Test Condition, Idle Mode  
All other pins are disconnected

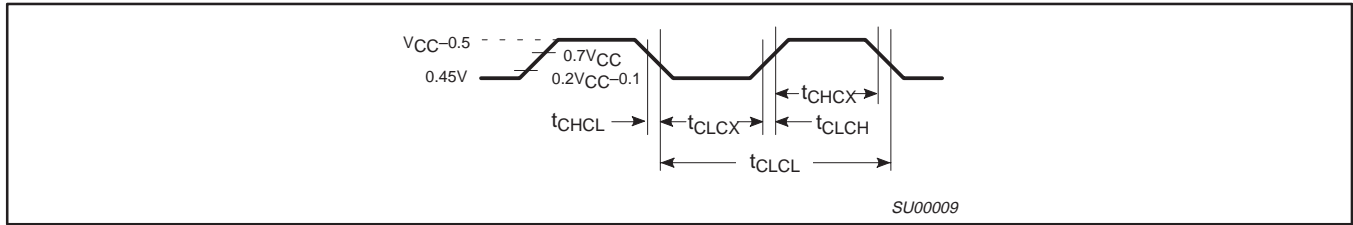

Figure 10. Clock Signal Waveform for I<sub>CC</sub> Tests in Active and Idle Modes  
t<sub>CLCH</sub> = t<sub>CHCL</sub> = 10 ns

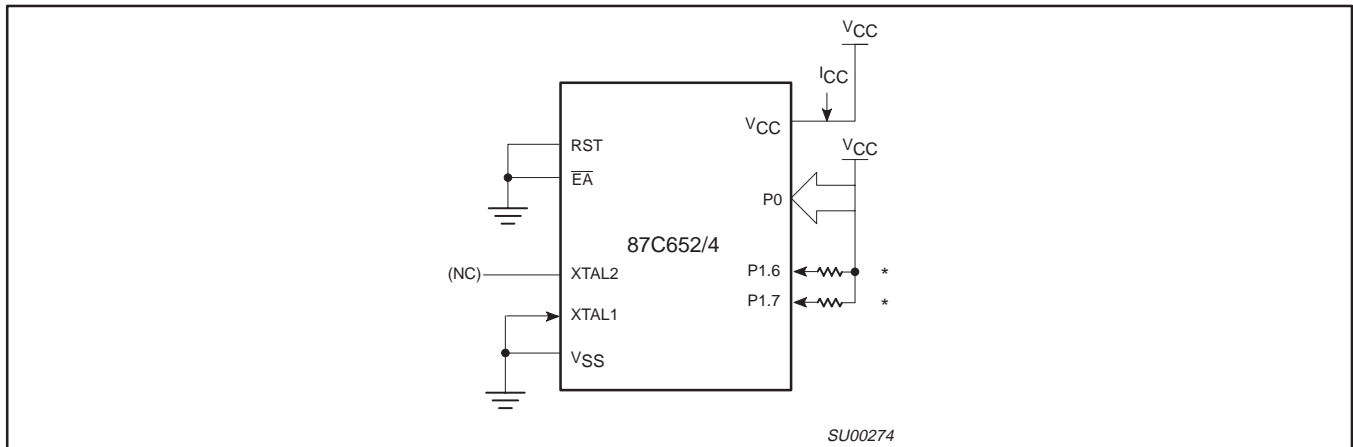

Figure 11. I<sub>CC</sub> Test Condition, Power Down Mode  
All other pins are disconnected. V<sub>CC</sub> = 2 V to 5.5 V

NOTE:

\* Ports 1.6 and 1.7 should be connected to V<sub>CC</sub> through resistors of sufficiently high value such that the sink current into these pins does not exceed the I<sub>OL1</sub> specification.



# 80C51 8-bit microcontroller 8K/16K, 256 OTP, I<sup>2</sup>C

## 87C652/87C654

### EPROM CHARACTERISTICS

The 87C652/87C654 is programmed by using a modified Quick-Pulse Programming™ algorithm. It differs from older methods in the value used for V<sub>PP</sub> (programming supply voltage) and in the width and number of the ALE/PROG pulses.

The 87C652/87C654 contains two signature bytes that can be read and used by an EPROM programming system to identify the device. The signature bytes identify the device as an 87C652/87C654 manufactured by Philips Components.

Table 4 shows the logic levels for reading the signature byte, and for programming the program memory, the encryption table, and the lock bits. The circuit configuration and waveforms for quick-pulse programming are shown in Figures 12 and 13. Figure 14 shows the circuit configuration for normal program memory verification.

### Quick-Pulse Programming

The setup for microcontroller quick-pulse programming is shown in Figure 12. Note that the 87C652/87C654 is running with a 4 to 6 MHz oscillator. The reason the oscillator needs to be running is that the device is executing internal address and program data transfers.

The address of the EPROM location to be programmed is applied to ports 1 and 2, as

shown in Figure 12. The code byte to be programmed into that location is applied to port 0. RST, PSEN and pins of ports 2 and 3 specified in Table 4 are held at the 'Program Code Data' levels indicated in Table 4. The ALE/PROG is pulsed low 25 times as shown in Figure 13.

To program the encryption table, repeat the 25 pulse programming sequence for addresses 0 through 1FH, using the 'Pgm Encryption Table' levels. Do not forget that after the encryption table is programmed, verification cycles will produce only encrypted data.

To program the lock bits, repeat the 25 pulse programming sequence using the 'Pgm Lock Bit' levels. After one lock bit is programmed, further programming of the code memory and encryption table is disabled. However, the other lock bit can still be programmed.

Note that the EA/V<sub>PP</sub> pin must not be allowed to go above the maximum specified V<sub>PP</sub> level for any amount of time. Even a narrow glitch above that voltage can cause permanent damage to the device. The V<sub>PP</sub> source should be well regulated and free of glitches and overshoot.

### Program Verification

If lock bit 2 has not been programmed, the on-chip program memory can be read out for

program verification. The address of the program memory locations to be read is applied to ports 1 and 2 as shown in Figure 14. The other pins are held at the 'Verify Code Data' levels indicated in Table 4. The contents of the address location will be emitted on port 0. External pull-ups are required on port 0 for this operation.

If the encryption table has been programmed, the data presented at port 0 will be the exclusive NOR of the program byte with one of the encryption bytes. The user will have to know the encryption table contents in order to correctly decode the verification data. The encryption table itself cannot be read out.

### Reading the Signature Bytes

The signature bytes are read by the same procedure as a normal verification of locations 030H and 031H, except that P3.6 and P3.7 need to be pulled to a logic low. The values are:

- (030H) = 15H indicates manufactured by Philips
- (031H) = 99H

### Program/Verify Algorithms

Any algorithm in agreement with the conditions listed in Table 4, and which satisfies the timing specifications, is suitable.

**Table 4. EPROM Programming Modes**

MODE	RST	PSEN	ALE/PROG	EA/V <sub>PP</sub>	P2.7	P2.6	P3.7	P3.6
Read signature	1	0	1	1	0	0	0	0
Program code data	1	0	0*	V <sub>PP</sub>	1	0	1	1
Verify code data	1	0	1	1	0	0	1	1
Pgm encryption table	1	0	0*	V <sub>PP</sub>	1	0	1	0
Pgm lock bit 1	1	0	0*	V <sub>PP</sub>	1	1	1	1
Pgm lock bit 2	1	0	0*	V <sub>PP</sub>	1	1	0	0

### NOTES:

1. '0' = Valid low for that pin, '1' = valid high for that pin.
  2. V<sub>PP</sub> = 12.75 V ±0.25 V.
  3. V<sub>CC</sub> = 5 V ±10% during programming and verification.
- \* ALE/PROG receives 25 programming pulses while V<sub>PP</sub> is held at 12.75 V. Each programming pulse is low for 100 μs (±10 μs) and high for a minimum of 10 μs.

™Trademark phrase of Intel Corporation.

80C51 8-bit microcontroller  
8K/16K, 256 OTP, I<sup>2</sup>C

87C652/87C654

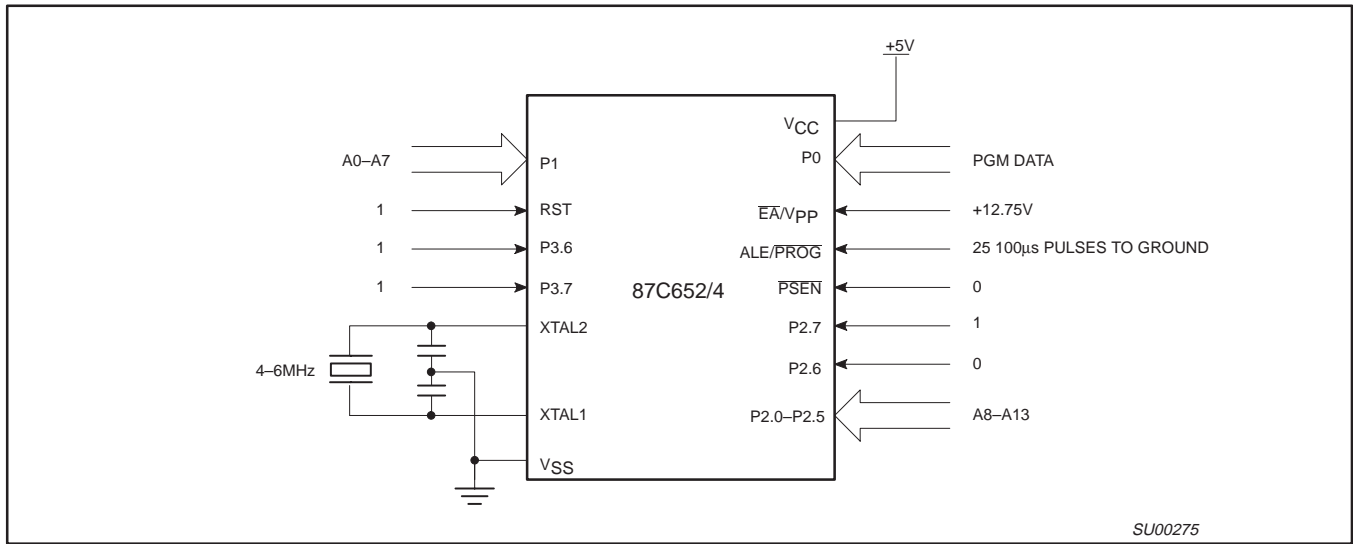

Figure 12. Programming Configuration

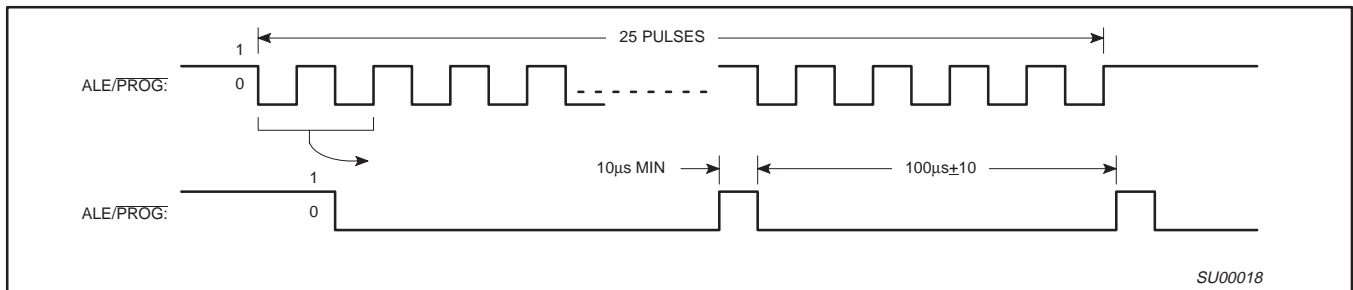

Figure 13. PROG Waveform

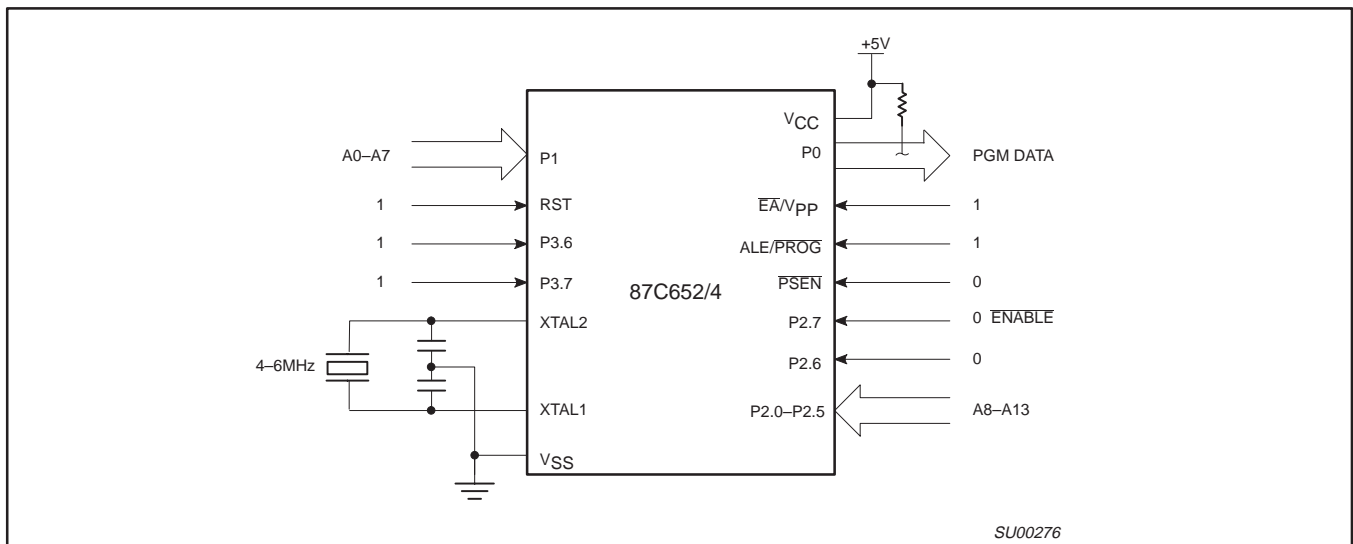

Figure 14. Program Verification

# 80C51 8-bit microcontroller 8K/16K, 256 OTP, I<sup>2</sup>C

87C652/87C654

## EPROM PROGRAMMING AND VERIFICATION CHARACTERISTICS

T<sub>amb</sub> = 21°C to +27°C, V<sub>CC</sub> = 5V±10%, V<sub>SS</sub> = 0V (See Figure 15)

SYMBOL	PARAMETER	MIN	MAX	UNIT
V <sub>PP</sub>	Programming supply voltage	12.5	13.0	V
I <sub>PP</sub>	Programming supply current		50	mA
1/t <sub>CLCL</sub>	Oscillator frequency	4	6	MHz
t <sub>AVGL</sub>	Address setup to $\overline{\text{PROG}}$ low	48t <sub>CLCL</sub>		
t <sub>GHAX</sub>	Address hold after $\overline{\text{PROG}}$	48t <sub>CLCL</sub>		
t <sub>DVGL</sub>	Data setup to $\overline{\text{PROG}}$ low	48t <sub>CLCL</sub>		
t <sub>GHDx</sub>	Data hold after $\overline{\text{PROG}}$	48t <sub>CLCL</sub>		
t <sub>EHS</sub>	P2.7 (ENABLE) high to V <sub>PP</sub>	48t <sub>CLCL</sub>		
t <sub>SHGL</sub>	V <sub>PP</sub> setup to $\overline{\text{PROG}}$ low	10		μs
t <sub>GHSL</sub>	V <sub>PP</sub> hold after $\overline{\text{PROG}}$	10		μs
t <sub>GLGH</sub>	$\overline{\text{PROG}}$ width	90	110	μs
t <sub>AVQV</sub>	Address to data valid		48t <sub>CLCL</sub>	
t <sub>ELQZ</sub>	ENABLE low to data valid		48t <sub>CLCL</sub>	
t <sub>EHQZ</sub>	Data float after ENABLE	0	48t <sub>CLCL</sub>	
t <sub>GHGL</sub>	$\overline{\text{PROG}}$ high to $\overline{\text{PROG}}$ low	10		μs

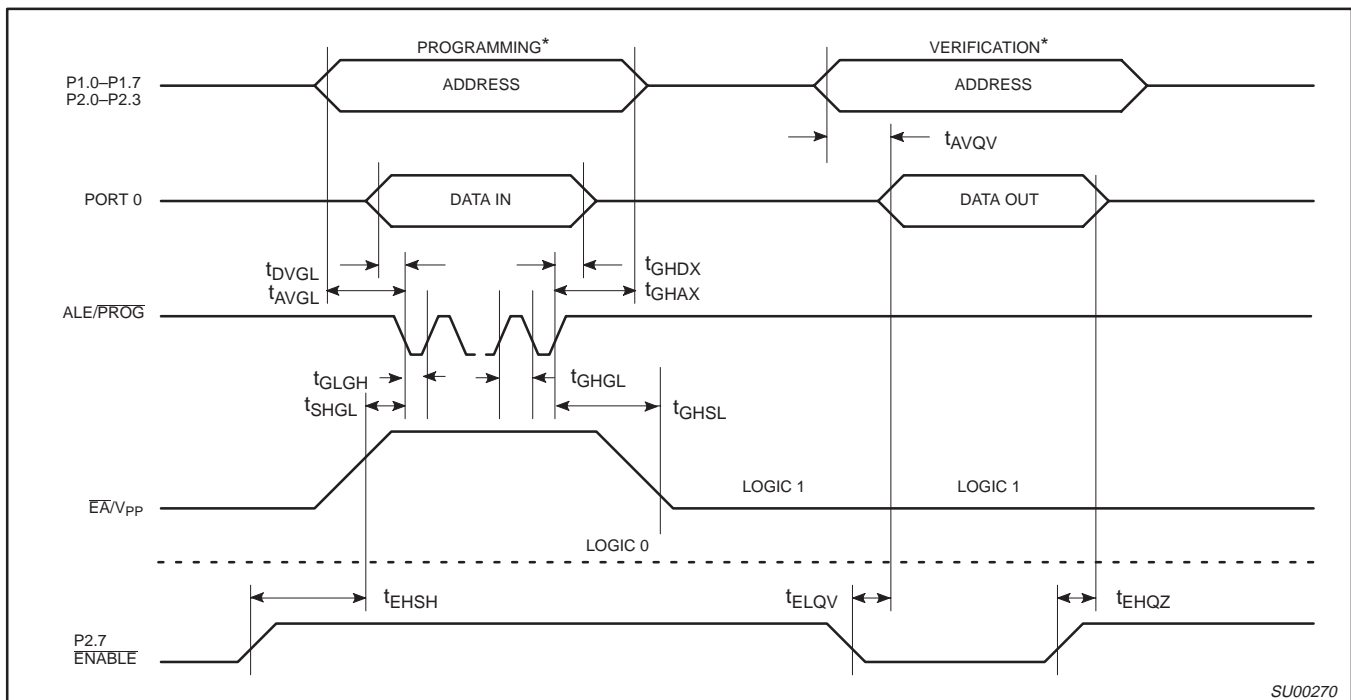

SU00270

\* FOR PROGRAMMING VERIFICATION SEE FIGURE 12.  
FOR VERIFICATION CONDITIONS SEE FIGURE 14.

Figure 15. EPROM Programming and Verification



Purchase of Philips I<sup>2</sup>C components conveys a license under the Philips' I<sup>2</sup>C patent to use the components in the I<sup>2</sup>C system provided the system conforms to the I<sup>2</sup>C specifications defined by Philips. This specification can be ordered using the code 9398 393 40011.

80C51 8-bit microcontroller  
8K/16K, 256 OTP, I<sup>2</sup>C

87C652/87C654

DIP40: plastic dual in-line package; 40 leads (600 mil)

SOT129-1

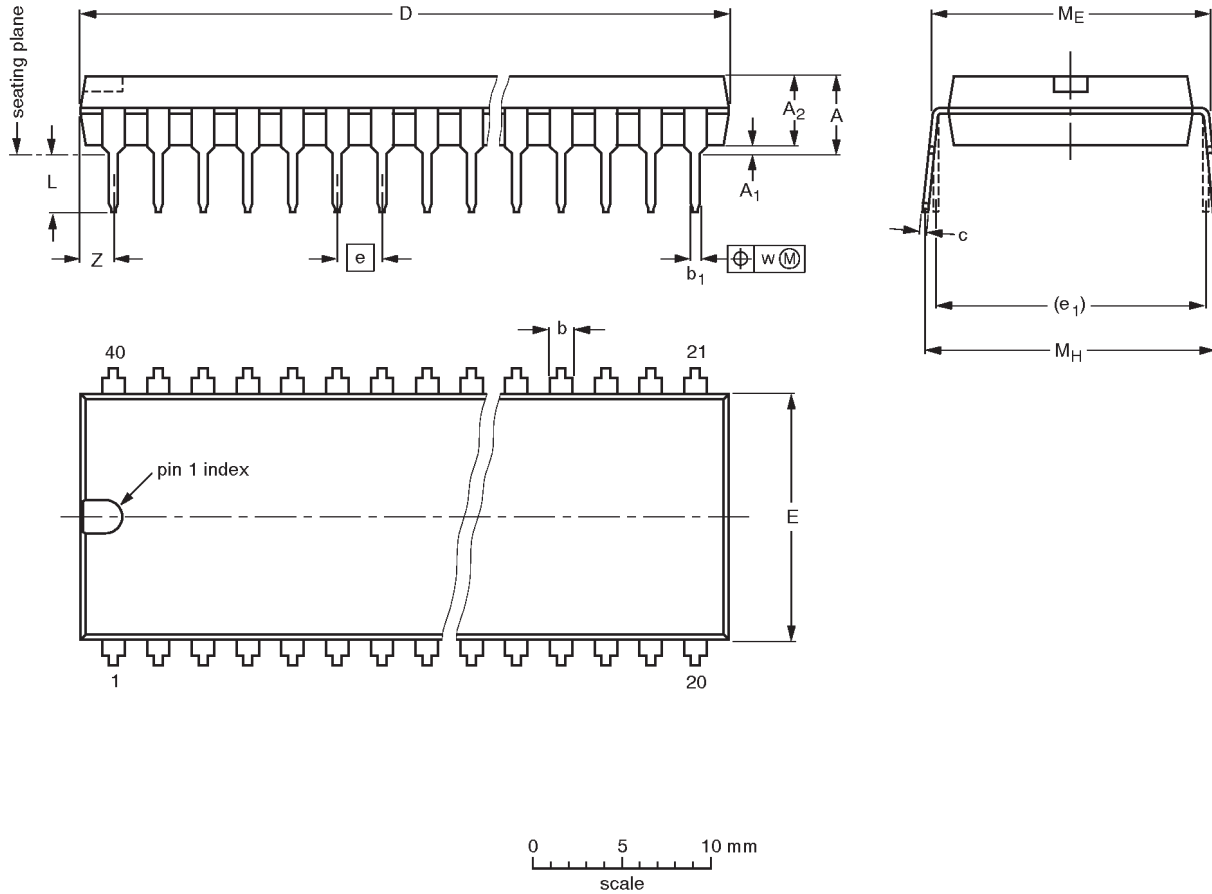

DIMENSIONS (inch dimensions are derived from the original mm dimensions)

UNIT	A max.	A <sub>1</sub> min.	A <sub>2</sub> max.	b	b <sub>1</sub>	c	D <sup>(1)</sup>	E <sup>(1)</sup>	e	e <sub>1</sub>	L	M <sub>E</sub>	M <sub>H</sub>	w	Z <sup>(1)</sup> max.
mm	4.7	0.51	4.0	1.70 1.14	0.53 0.38	0.36 0.23	52.50 51.50	14.1 13.7	2.54	15.24	3.60 3.05	15.80 15.24	17.42 15.90	0.254	2.25
inches	0.19	0.020	0.16	0.067 0.045	0.021 0.015	0.014 0.009	2.067 2.028	0.56 0.54	0.10	0.60	0.14 0.12	0.62 0.60	0.69 0.63	0.01	0.089

Note

1. Plastic or metal protrusions of 0.25 mm maximum per side are not included.

OUTLINE VERSION	REFERENCES				EUROPEAN PROJECTION	ISSUE DATE
	IEC	JEDEC	EIAJ			
SOT129-1	051G08	MO-015AJ				92-11-17 95-01-14

80C51 8-bit microcontroller  
8K/16K, 256 OTP, I<sup>2</sup>C

87C652/87C654

PLCC44: plastic leaded chip carrier; 44 leads

SOT187-2

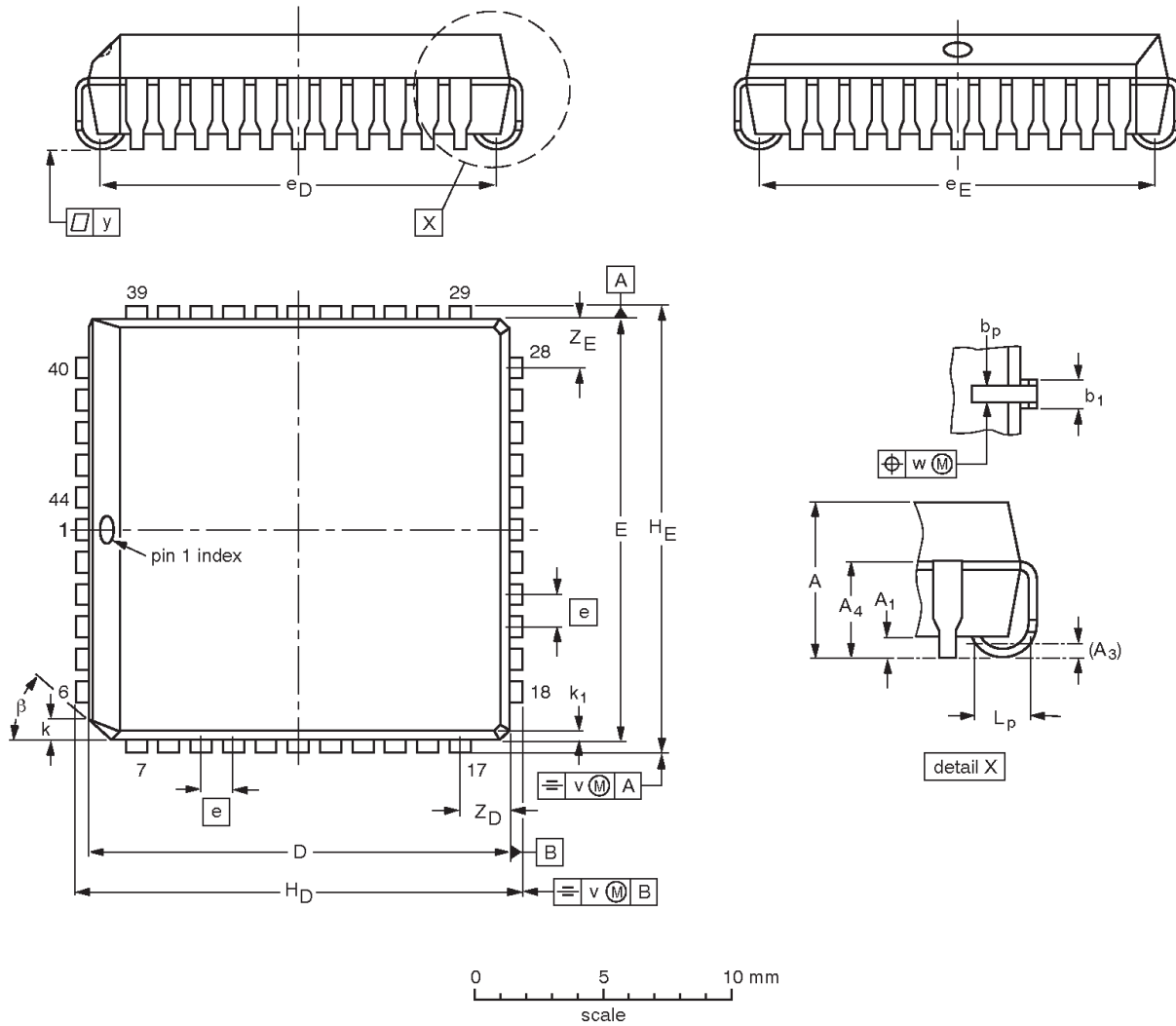

DIMENSIONS (millimetre dimensions are derived from the original inch dimensions)

UNIT	A	A <sub>1</sub> min.	A <sub>3</sub>	A <sub>4</sub> max.	b <sub>p</sub>	b <sub>1</sub>	D <sup>(1)</sup>	E <sup>(1)</sup>	e	e <sub>D</sub>	e <sub>E</sub>	H <sub>D</sub>	H <sub>E</sub>	k	k <sub>1</sub> max.	L <sub>p</sub>	v	w	y	Z <sub>D</sub> <sup>(1)</sup> max.	Z <sub>E</sub> <sup>(1)</sup> max.	β
mm	4.57 4.19	0.51	0.25	3.05	0.53 0.33	0.81 0.66	16.66 16.51	16.66 16.51	1.27	16.00 14.99	16.00 14.99	17.65 17.40	17.65 17.40	1.22 1.07	0.51	1.44 1.02	0.18	0.18	0.10	2.16	2.16	45°
inches	0.180 0.165	0.020	0.01	0.12	0.021 0.013	0.032 0.026	0.656 0.650	0.656 0.650	0.05	0.630 0.590	0.630 0.590	0.695 0.685	0.695 0.685	0.048 0.042	0.020	0.057 0.040	0.007	0.007	0.004	0.085	0.085	

Note

1. Plastic or metal protrusions of 0.01 inches maximum per side are not included.

OUTLINE VERSION	REFERENCES				EUROPEAN PROJECTION	ISSUE DATE
	IEC	JEDEC	EIAJ			
SOT187-2	112E10	MO-047AC				95-02-25 97-12-16

80C51 8-bit microcontroller  
8K/16K, 256 OTP, I<sup>2</sup>C

87C652/87C654

**QFP44: plastic quad flat package; 44 leads (lead length 1.3 mm); body 10 x 10 x 1.75 mm**

**SOT307-2**

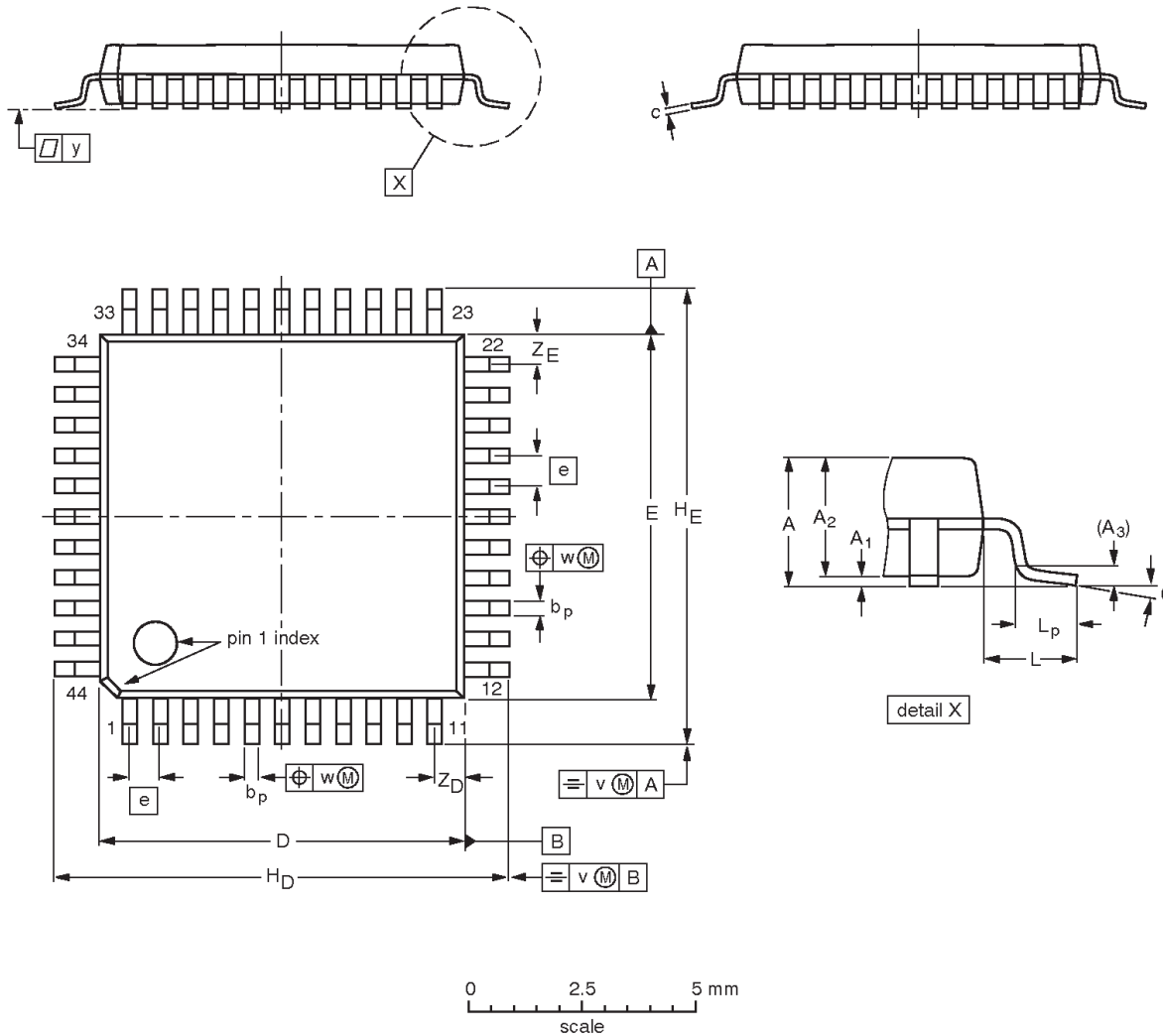

**DIMENSIONS (mm are the original dimensions)**

UNIT	A <sub>max.</sub>	A <sub>1</sub>	A <sub>2</sub>	A <sub>3</sub>	b <sub>p</sub>	c	D <sup>(1)</sup>	E <sup>(1)</sup>	e	H <sub>D</sub>	H <sub>E</sub>	L	L <sub>p</sub>	v	w	y	Z <sub>D</sub> <sup>(1)</sup>	Z <sub>E</sub> <sup>(1)</sup>	θ
mm	2.10	0.25 0.05	1.85 1.65	0.25	0.40 0.20	0.25 0.14	10.1 9.9	10.1 9.9	0.8	12.9 12.3	12.9 12.3	1.3	0.95 0.55	0.15	0.15	0.1	1.2 0.8	1.2 0.8	10° 0°

**Note**

1. Plastic or metal protrusions of 0.25 mm maximum per side are not included.

OUTLINE VERSION	REFERENCES				EUROPEAN PROJECTION	ISSUE DATE
	IEC	JEDEC	EIAJ			
SOT307-2						95-02-04 97-08-01

---

80C51 8-bit microcontroller  
8K/16K, 256 OTP, I<sup>2</sup>C

---

87C652/87C654

---

**NOTES**

80C51 8-bit microcontroller  
8K/16K, 256 OTP, I<sup>2</sup>C

87C652/87C654

### Data sheet status

Data sheet status	Product status	Definition [1]
Objective specification	Development	This data sheet contains the design target or goal specifications for product development. Specification may change in any manner without notice.
Preliminary specification	Qualification	This data sheet contains preliminary data, and supplementary data will be published at a later date. Philips Semiconductors reserves the right to make changes at any time without notice in order to improve design and supply the best possible product.
Product specification	Production	This data sheet contains final specifications. Philips Semiconductors reserves the right to make changes at any time without notice in order to improve design and supply the best possible product.

[1] Please consult the most recently issued datasheet before initiating or completing a design.

### Definitions

**Short-form specification** — The data in a short-form specification is extracted from a full data sheet with the same type number and title. For detailed information see the relevant data sheet or data handbook.

**Limiting values definition** — Limiting values given are in accordance with the Absolute Maximum Rating System (IEC 134). Stress above one or more of the limiting values may cause permanent damage to the device. These are stress ratings only and operation of the device at these or at any other conditions above those given in the Characteristics sections of the specification is not implied. Exposure to limiting values for extended periods may affect device reliability.

**Application information** — Applications that are described herein for any of these products are for illustrative purposes only. Philips Semiconductors make no representation or warranty that such applications will be suitable for the specified use without further testing or modification.

### Disclaimers

**Life support** — These products are not designed for use in life support appliances, devices or systems where malfunction of these products can reasonably be expected to result in personal injury. Philips Semiconductors customers using or selling these products for use in such applications do so at their own risk and agree to fully indemnify Philips Semiconductors for any damages resulting from such application.

**Right to make changes** — Philips Semiconductors reserves the right to make changes, without notice, in the products, including circuits, standard cells, and/or software, described or contained herein in order to improve design and/or performance. Philips Semiconductors assumes no responsibility or liability for the use of any of these products, conveys no license or title under any patent, copyright, or mask work right to these products, and makes no representations or warranties that these products are free from patent, copyright, or mask work right infringement, unless otherwise specified.

Philips Semiconductors  
811 East Arques Avenue  
P.O. Box 3409  
Sunnyvale, California 94088-3409  
Telephone 800-234-7381

© Copyright Philips Electronics North America Corporation 1999  
All rights reserved. Printed in U.S.A.

Date of release: 07-99

Document order number:

9397-750-06607

*Let's make things better.*