

DATA SHEET

PCA82C252 Fault-tolerant CAN transceiver

Product specification
Supersedes data of 1997 Mar 07
File under Integrated Circuits, IC18

1997 Oct 28

Fault-tolerant CAN transceiver

PCA82C252

FEATURES

Optimized for in-car low-speed communication

- Baud rate up to 125 kBaud
- Up to 15 nodes can be connected
- Supports unshielded bus wires
- Low RFI due to built-in slope control function
- Fully integrated receiver filters.

Bus failure management

- Supports one-wire transmission modes with ground offset voltages up to 1.5 V
- Automatic switching to single-wire mode in the event of bus failure
- Automatic reset to differential mode if bus failure is removed.

Protection

- Short-circuit proof to battery and ground in 12 V powered systems

- Thermally protected
- Bus lines protected against transients in an automotive environment
- An unpowered node does not disturb the bus lines.

Support for low-power modes

- Low current sleep/standby mode with wake-up via the bus lines
- Power-on reset flag on the output.

GENERAL DESCRIPTION

The PCA82C252 is the interface between the CAN protocol controller and the physical bus. It is primarily intended for low-speed applications, up to 125 kBaud, in passenger cars. The device provides differential transmit capability but will switch in error conditions to a single-wire transmitter and/or receiver.

QUICK REFERENCE DATA

SYMBOL	PARAMETER	CONDITIONS	MIN.	TYP.	MIN.	UNIT
V_{CC}	supply voltage		4.75	–	5.25	V
V_{BAT}	battery voltage	no time limit	–0.3	–	+27	V
		operating	6.0	–	27	V
		load dump	–	–	40	V
I_{sleep}	sleep mode current	$V_{CC} = 0\text{ V}; V_{BAT} = 12\text{ V}$	–	50	–	μA
V_{CANH}, V_{CANL}	CANH, CANL input voltage	$V_{CC} = 0\text{ to }5.5\text{ V}; V_{BAT} \geq 0\text{ V};$ no time limit	–10	–	+27	V
		$V_{CC} = 0\text{ to }5.5\text{ V}; V_{BAT} \geq 0\text{ V};$ $t < 0.1\text{ ms};$ load dump	–40	–	+40	V
$V_{DROP(H)}$	CANH transmitter drop voltage	$I_{CANH} = 40\text{ mA}$	–	–	1.4	V
$V_{DROP(L)}$	CANL transmitter drop voltage	$I_{CANL} = 40\text{ mA}$	–	–	1.4	V
t_{PD}	propagation delay	TXD to RXD	–	1	–	μs
t_f	bus output fall time	90% to 10%	–	0.5	–	μs
t_r	bus output rise time	10% to 90%	–	0.5	–	μs
T_{amb}	operating ambient temperature		–40	–	+125	$^{\circ}\text{C}$

ORDERING INFORMATION

TYPE NUMBER	PACKAGE		
	NAME	DESCRIPTION	VERSION
PCA82C252T	SO14	plastic small outline package; 14 leads; body width 3.9 mm	SOT108-1

Fault-tolerant CAN transceiver

PCA82C252

BLOCK DIAGRAM

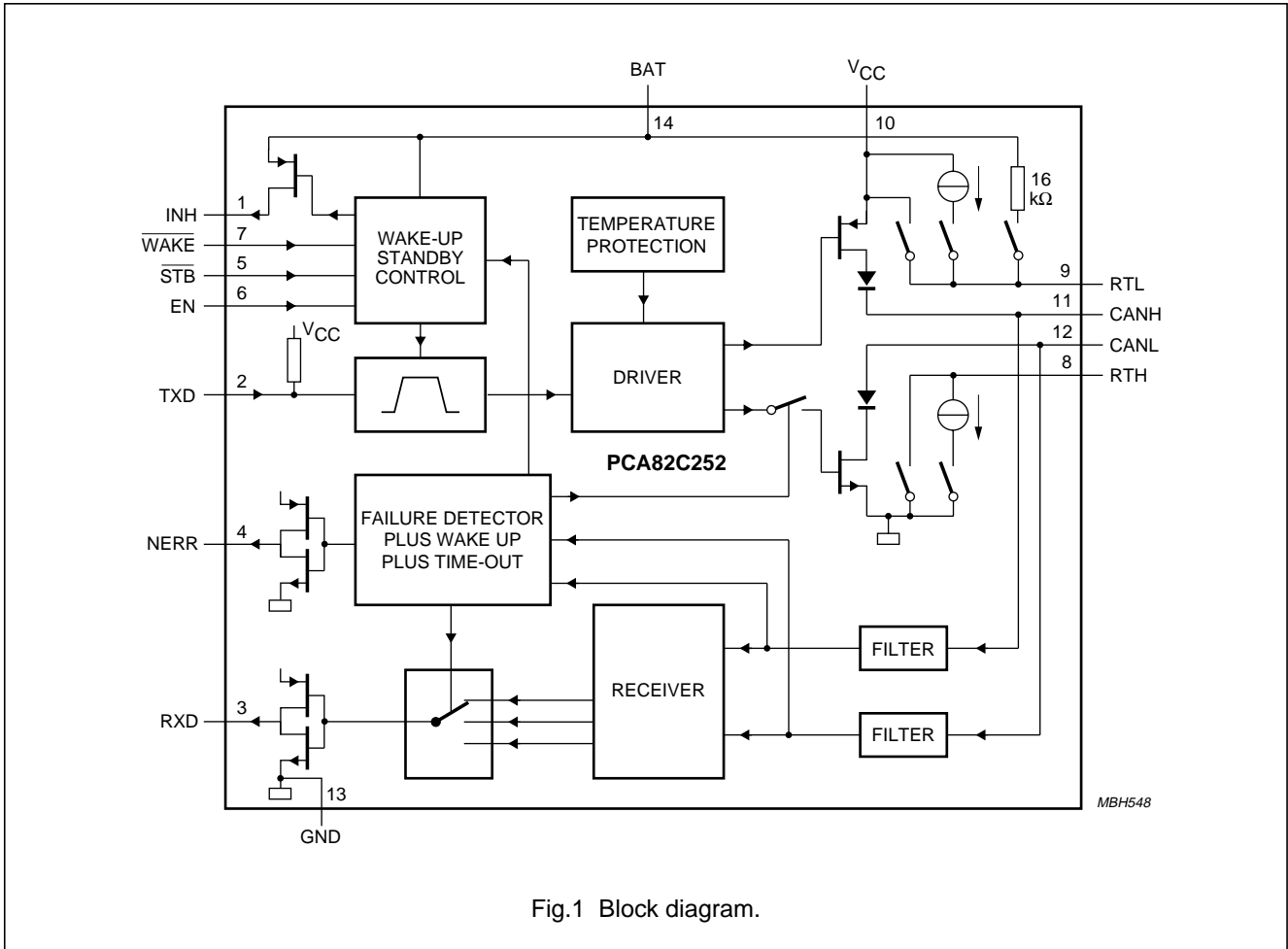

Fig.1 Block diagram.

Fault-tolerant CAN transceiver

PCA82C252

PINNING

SYMBOL	PIN	DESCRIPTION
INH	1	inhibit output for switching external 5 V regulator
TXD	2	transmit data input, when LOW bus data will be dominant, when HIGH bus data will be recessive
RXD	3	receive data output, when LOW bus data will be dominant
NERR	4	error output pin, when LOW a bus error exists
$\overline{\text{STB}}$	5	not standby digital control input signal (active LOW)
EN	6	enable digital control input signal
$\overline{\text{WAKE}}$	7	not wake input signal, when pulled down INH becomes active for wake-up (active LOW)
RTH	8	termination resistor, CANH line will be high-impedance with certain bus errors
RTL	9	termination resistor, CANL line will be high-impedance with certain bus errors
V _{CC}	10	supply voltage (+5 V)
CANH	11	high voltage bus line, will be HIGH in dominant state
CANL	12	low voltage bus line, will be LOW in dominant state
GND	13	ground
BAT	14	battery voltage

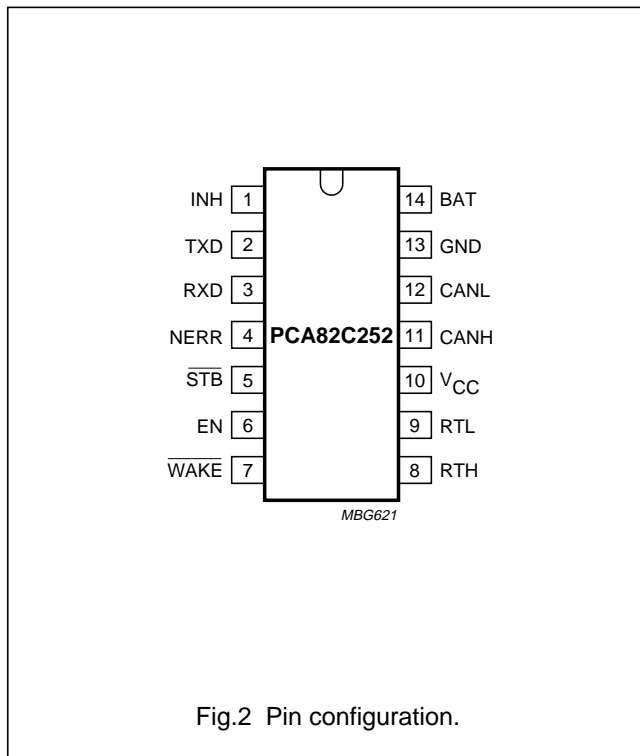

Fault-tolerant CAN transceiver

PCA82C252

FUNCTIONAL DESCRIPTION

The PCA82C252 is the interface between the CAN protocol controller and the physical bus. It is primarily intended for low speed applications, up to 125 kbaud, in passenger cars. The device provides differential transmit capability to the bus and differential receive capability to the CAN controller.

To reduce RF interference the rise and fall slope are limited. This allows the use of an unshielded twisted pair or a parallel pair of wires for the bus. Moreover, it supports transmission capability on either bus wire if one of the bus wires is corrupted. The failure detection logic automatically selects a suitable transmission mode.

In normal operation (no wiring failures) the differential receiver is output to RXD. The differential receiver inputs are connected to CANH and CANL through integrated filters. The filtered input signals are also used for the single wire receivers. The CANH and CANL receivers have threshold voltages that ensure a maximum noise margin in single-wire modes.

Failure detector

The failure detector is active in the normal operation mode and detects the following single bus failures and switches to an appropriate mode:

1. CANH wire interrupted
2. CANL wire interrupted
3. CANH short-circuited to battery
4. CANL short-circuited to ground
5. CANH short-circuited to ground
6. CANL short-circuited to battery
7. CANL mutually shorted to CANH.

The differential receiver threshold is set at -2.9 V. This ensures correct reception in the normal operating modes and, in the event of failures 1, 2 and 5 with a noise margin as high as possible. These failures, or recovery from them, do not destroy ongoing transmissions. To ensure speed requirements the differential receiver has an acceleration function.

Failures 3 and 6 are detected by comparators connected to CANH and CANL, respectively. If the comparator threshold is exceeded for a certain period of time, the reception is switched to the single-wire mode. This time is needed to avoid false triggering by external RF fields. Recovery from these failures is detected automatically after a certain time-out (filtering) and no transmission is lost.

Failures 4 and 7 initially result in a permanent dominant level at RXD. After a time-out, the CANL driver and the RTL pin are switched off. Only a weak pull-up at RTL remains. Reception continues by switching to the single-wire mode via CANH. When failures 4 or 7 are removed, the recessive bus levels are restored. If the differential voltage remains below the recessive threshold level for a certain period of time, reception and transmission switch back to the differential mode.

If any of the seven wiring failures occur, the output NERR will be made LOW. On error recovery, NERR will be made HIGH again.

During all single-wire transmissions, the EMC performance (both immunity and emission) is worse than in the differential mode. Integrated receiver filters suppress any HF noise induced into the bus wires. The cut-off frequency of these filters is a compromise between propagation delay and HF suppression. In the single-wire mode, low frequency noise cannot be distinguished from the required signal.

Low power modes

The transceiver provides 3 low power modes which can be entered and exited via pins STB and EN.

The sleep mode is the mode with the lowest power consumption. The INH pin is switched to high-impedance for deactivation of external voltage regulators. CANL is biased to the battery voltage via the RTL output. If the supply voltage is provided the RXD and NERR will signal the wake-up interrupt

The V_{BAT} standby mode will react the same as the sleep mode with an active INH output.

The V_{CC} standby mode is the V_{BAT} standby with RTL switched to the V_{CC} voltage. In this mode the NERR output signals the V_{BAT} power-on flag and the RXD output will show the wake-up interrupt.

Wake-up requests are recognized by the transceiver when a dominant signal is detected on either bus line or if the WAKE pin is connected to ground. On a wake-up request the transceiver will set the INH output which can be used to activate the external V_{CC} voltage regulator. If V_{CC} is provided the wake-up request can be read on the NERR or RXD outputs, on which the external microcontroller can wake up the transceiver (switch to normal operating mode) via STB and EN.

Fault-tolerant CAN transceiver

PCA82C252

To prevent false wake-up due to transients or RF fields, wake-up voltage threshold levels have to be maintained for a certain period of time. In the low power modes the failure detection circuit remains partly active to prevent increased power consumption should errors 3, 4 and 7 occur.

Power on

After power-on V_{BAT} is switched on, the INH pin will become HIGH and an internal power-on flag will be set. This flag can be read via the NERR pin ($\overline{STB} = 1$, $EN = 0$) and will be reset by entering the normal operation mode.

The EN and \overline{STB} pins will internally be set to LOW level, if the V_{CC} voltage is below a certain threshold level, to provide fail safe functionality.

Protections

A current limiting circuit protects the transmitter output stages against short-circuit to positive and negative battery voltage.

If the junction temperature exceeds a maximum value, the transmitter output stages are disabled. Because the transmitter is responsible for the major part of the power dissipation, this will result in a reduced power dissipation and hence a lower chip temperature. All other parts of the IC will remain operating.

The CANH and CANL inputs are protected against electrical transients which may occur in an automotive environment.

Table 1 Truth table of CAN transceiver

\overline{STB}	EN	MODE	INH	NERR	RXD	RTL
0	0	V_{BAT} standby ⁽¹⁾	HIGH	LOW active wake-up interrupt signal if V_{CC} is present		switched to V_{BAT}
0	0	sleep ⁽²⁾	floating			switched to V_{BAT}
0	1	go to sleep command	floating			switched to V_{BAT}
1	0	V_{CC} standby ⁽³⁾	HIGH	LOW active V_{BAT} power-on flag	LOW active wake-up interrupt	switched to V_{CC}
1	1	normal operation mode	HIGH	LOW active error flag	HIGH = receive; LOW = dominant received data	switched to V_{CC}

Notes

1. Wake-up interrupts are released when entering normal operating mode.
2. If go to sleep command was used before (EN may turn LOW as V_{CC} drops, without affecting internal functions because of fail safe functionality).
3. V_{BAT} power-on flag will be reset when entering normal operation mode.

Fault-tolerant CAN transceiver

PCA82C252

LIMITING VALUES

In accordance with the Absolute Maximum Rating System (IEC 134).

SYMBOL	PARAMETER	CONDITIONS	MIN.	MAX.	UNIT
V _{CC}	supply voltage		-0.3	+6.0	V
V _{DD}	DC input voltage at pins 2 to 6		-0.3	V _{CC} + 0.3	V
V _{BUS}	DC input voltage at pins 11 and 12		-10	+27	V
V _{CANH,L}	DC input voltage at pins 11 and 12	V _{CC} = 0 to 5.5 V; V _{BAT} ≥ 0 V; t < 0.1 ms; load dump	-40	+40	V
V _{tr}	transient voltage at pins 11 and 12	see Fig.6	-150	+100	V
V _{WAKE}	DC input voltage on pin 7		-	V _{BAT} + 0.3	V
I _{WAKE}	input current pin 7		-15	-	mA
V _{1,8,9}	DC input voltage on pins 1, 8 and 9		-0.3	V _{BAT} + 0.3	V
V _{BAT}	DC input voltage on pin 14		-0.3	+27	V
	voltage on pin 14	load dump; 500 ms	-	40	V
R _{8,9}	termination resistances pins 8 and 9		500	16000	Ω
T _{vj}	virtual junction temperature	note 1	-40	+150	°C
T _{stg}	storage temperature		-55	+150	°C
V _{esd}	electrostatic discharge voltage at any pin	note 2	-2000	+2000	V
		note 3	-200	+200	V

Notes

1. Junction temperature in accordance with IEC 747-1. An alternative definition is: $T_{vj} = T_{amb} + PD \times R_{th\ vj-a}$.
Where; $R_{th\ vj-a}$ is a fixed value to be used for the calculation of T_{vj} . The rating for T_{vj} limits the allowable combinations of power dissipation and ambient temperature.
2. Human body model: equivalent to discharging a 100 pF capacitor through a 1.5 kΩ resistor.
3. Machine model: equivalent to discharging a 200 pF capacitor through a 25 Ω resistor.

THERMAL CHARACTERISTICS

SYMBOL	PARAMETER	CONDITIONS	VALUE	UNIT
R _{th vj-a}	thermal resistance from junction to ambient	in free air	120	K/W

QUALITY SPECIFICATION

Quality specification in accordance with "SNW-FQ-611-Part-E".

Fault-tolerant CAN transceiver

PCA82C252

CHARACTERISTICS

$V_{CC} = 4.75$ to 5.25 V; $V_{\overline{STB}} = V_{CC}$; $V_{BAT} = 6$ V to 27 V; $T_{amb} = -40$ to $+125$ °C; unless otherwise specified. All voltages are defined with respect to ground. Positive currents flow into the IC. All parameters are guaranteed over the temperature range by design, but only 100% tested at 25 °C.

SYMBOL	PARAMETER	CONDITIONS	MIN.	TYP.	MAX.	UNIT
Supplies						
I_{CC}	supply current	recessive; TXD = V_{CC} ; normal operating mode	–	6	10	mA
		dominant; TXD = 0 V; no load; normal operating mode	–	29	35	mA
$I_{CC} + I_{BAT}$	supply current (V_{CC} standby)	$V_{CC} = 5$ V; $V_{BAT} = 12$ V; $T_{amb} < 90$ °C	–	120	1000	μ A
	supply current (V_{BAT} standby)	$V_{CC} = 5$ V; $V_{BAT} = 12$ V; $T_{amb} < 90$ °C	–	55	80	μ A
I_{BAT}	supply current (sleep mode)	$V_{CC} = 0$ V; $V_{BAT} = 12$ V; $T_{amb} < 90$ °C	–	50	75	μ A
V_{BAT}	battery voltage for setting power-on flag	low power modes	–	–	1.0	V
t_{pwon}	battery voltage low time for setting power-on flag	low power modes	1	–	–	s
Pins \overline{STB}, EN and TXD						
V_{IH}	HIGH level input voltage		$0.7V_{CC}$	–	$V_{CC} + 0.3$	V
V_{IL}	LOW level input voltage		–0.3	–	$0.3V_{CC}$	V
I_{IH}	HIGH level input current (pins \overline{STB} and EN)	$V_i = 4$ V	–	9	20	μ A
I_{IL}	LOW level input current (pins \overline{STB} and EN)	$V_i = 1$ V	4	8	–	μ A
I_{IH}	HIGH level input current (pin TXD)	$V_i = 4$ V	–25	–80	–200	μ A
I_{IL}	LOW level input current (pin TXD)	$V_i = 1$ V	–100	–320	–800	μ A
V_{CC}	forced battery voltage standby mode (fail safe)		2.75	–	4.5	V
Pins RXD and NERR						
V_{OH}	HIGH level output voltage (pin NERR)	$I_o = -100$ μ A	$V_{CC} - 0.9$	–	V_{CC}	V
V_{OH}	HIGH level output voltage (pin RXD)	$I_o = -250$ μ A	$V_{CC} - 0.9$	–	V_{CC}	V
V_{OL}	LOW level output voltage	$I_o = 1.25$ mA	0	–	0.9	V
Pin WAKE						
I_{IL}	LOW level input current	$V_{\overline{WAKE}} = 0$ V; $V_{BAT} = 27$ V	–10	–120	–250	μ A
$V_{wu(th)}$	wake-up threshold voltage	$V_{\overline{STB}} = 0$ V	1.2	–	3.2	V

Fault-tolerant CAN transceiver

PCA82C252

SYMBOL	PARAMETER	CONDITIONS	MIN.	TYP.	MAX.	UNIT
Pin INH						
V_{dropH}	HIGH level voltage drop	$I_{\text{INH}} = -0.18 \text{ mA}; V_{\text{BAT}} < 16 \text{ V}$	–	–	0.8	V
		$I_{\text{INH}} = -0.18 \text{ mA}; V_{\text{BAT}} > 16 \text{ V}$	–	–	1.0	V
I_{LI}	leakage current	sleep mode; $V_{\text{INH}} = 0 \text{ V}$	–	–	5.0	μA
Pins CANH and CANL						
$V_{\text{drx(rd)}}$	differential receiver recessive-to-dominant threshold voltage		–3.25	–	–2.65	V
$V_{\text{drx(dr)}}$	differential receiver dominant-to-recessive threshold voltage	no bus failures	0.4	0.7	1.0	V
		bus failures 1, 2 and 5	–3.25	–	–2.65	V
V_{oCANHrec}	CANH recessive output voltage	$\text{TXD} = V_{\text{CC}}; R_{\text{RTH}} < 4 \text{ k}\Omega$	–	–	0.2	V
V_{oCANLrec}	CANL recessive output voltage	$\text{TXD} = V_{\text{CC}}; R_{\text{RTL}} < 4 \text{ k}\Omega$	$V_{\text{CC}} - 0.2$	–	–	V
V_{oCANHdom}	CANH dominant output voltage	$\text{TXD} = 0 \text{ V}; V_6 = V_{\text{CC}};$ $I_{\text{CANH}} = -40 \text{ mA}$	$V_{\text{CC}} - 1.4$	–	–	V
V_{oCANLdom}	CANL dominant output voltage	$\text{TXD} = 0 \text{ V}; V_6 = V_{\text{CC}};$ $I_{\text{CANL}} = 40 \text{ mA}$	–	–	1.4	V
I_{oCANH}	CANH output current	$V_{\text{CANH}} = 0 \text{ V}; \text{TXD} = 0 \text{ V}$	–	–75	–100	mA
		sleep mode; $V_{\text{CANH}} = 12 \text{ V}$	–	0	–	μA
I_{oCANL}	CANL output current	$V_{\text{CANL}} = 14 \text{ V}; \text{TXD} = 0 \text{ V}$	–	90	130	mA
		sleep mode; $V_{\text{CANL}} = 0 \text{ V},$ $V_{\text{BAT}} = 12 \text{ V}$	–	0	–	μA
V_{detth}	voltage detection threshold for short-circuit to battery voltage on CANH and CANL	normal mode	6.5	7.3	8.0	V
V_{detth}	voltage detection threshold for short-circuit to battery voltage on CANH	standby/sleep mode	$V_{\text{BAT}} - 2.5$	–	$V_{\text{BAT}} - 1$	V
V_{wuL}	CANL wake-up voltage threshold		2.4	3.1	3.8	V
V_{wuH}	CANH wake-up voltage threshold		1.2	1.9	2.7	V
ΔV_{wu}	wake-up voltage threshold difference		0.2	–	–	V
V_{CANH}	CANH single-ended receiver threshold	failures 4, 6 and 7	1.5	1.82	2.15	V
V_{CANL}	CANL single-ended receiver threshold voltage	failure 3	2.8	3.1	3.4	V

Fault-tolerant CAN transceiver

PCA82C252

SYMBOL	PARAMETER	CONDITIONS	MIN.	TYP.	MAX.	UNIT
Pins RTH and RTL						
R _{RTL}	RTL to V _{CC} switch-on resistance	I _o < 10 mA; normal operating mode	–	7	25	Ω
		I _o < 1 mA; V _{CC} standby mode	–	15	75	Ω
	RTL to BAT switch series resistance	V _{BAT} standby or sleep mode	10	16	28	kΩ
R _{RTH}	RTH to ground switch-on resistance	I _o < 10 mA; normal operating mode	–	43	95	Ω
V _{oRTH}	RTH output voltage	I _o = 1 mA; low power modes	–	0.7	1.0	V
I _{RTLpu}	RTL pull-up current	normal operating mode, failures 4, 6 and 7	–	75	–	μA
I _{RTHpd}	RTH pull-down current	normal operating mode, failure 3	–	75	–	μA
Thermal shutdown						
T _{jsd}	shut down junction temperature		155	165	180	°C

AC CHARACTERISTICS

V_{CC} = 4.75 to 5.25 V; V_{STB} = V_{CC}; V_{BAT} = 6 V to 27 V; T_{amb} = –40 to +125 °C; unless otherwise specified. All voltages are defined with respect to ground. Positive currents flow into the IC. All parameters are guaranteed over the temperature range by design, but only 100% tested at 25 °C.

SYMBOL	PARAMETER	CONDITIONS	MIN.	TYP.	MAX.	UNIT
t _{rd}	CANL and CANH bus output transition time recessive-to-dominant	10% to 90%; C1 = 10 nF; C2 = 0; R1 = 100 Ω	0.6	0.85	–	μs
t _{dr}	CANL and CANH bus output transition time dominant-to-recessive	10% to 90%; C1 = 1 nF; C2 = 0; R1 = 100 Ω	0.3	0.4	–	μs
t _{PD(L)}	propagation delay TXD-to-RXD LOW	C1 = 100 pF; C2 = 0; R1 = 100 Ω; no failures and bus failures 1, 2 and 5	–	0.75	1.25	μs
		C1 = C2 = 3.3 nF; R1 = 100 Ω; no failures and bus failures 1, 2 and 5	–	1	1.5	μs
		C1 = 100 pF; C2 = 0; R1 = 100 Ω; bus failures 3, 4, 6 and 7	–	0.85	1.3	μs
		C1 = C2 = 3.3 nF; R1 = 100 Ω; bus failures 3, 4, 6 and 7	–	1.1	1.7	μs

Fault-tolerant CAN transceiver

PCA82C252

SYMBOL	PARAMETER	CONDITIONS	MIN.	TYP.	MAX.	UNIT
$t_{PD(H)}$	propagation delay TXD-to-RXD HIGH	C1 = 100 pF; C2 = 0; R ₁ = 100 Ω ; no failures and bus failures 1, 2 and 5	–	0.75	1.25	μ s
		C1 = C2 = 3.3 nF; R ₁ = 100 Ω ; no failures and bus failures 1 and 2	–	1	1.5	μ s
		C1 = 100 pF; C2 = 0; R ₁ = 100 Ω ; bus failures 3, 4, 6 and 7	–	0.85	1.3	μ s
		C1 = C2 = 3.3 nF; R ₁ = 100 Ω ; bus failures 3, 4, 5, 6 and 7	–	1.4	2.1	μ s
$t_{wo(min)}$	minimum dominant time for wake-up on CANL or CANH	low power modes $V_{BAT} = 12$ V	8	–	38	μ s
$t_{WAKE(min)}$	minimum \overline{WAKE} LOW time for wake-up	low power modes $V_{BAT} = 12$ V	8	–	38	μ s
t_{fail}	failures 3 and 6 detection time	normal mode	10	–	60	μ s
	failure 3 recovery time	normal mode	10	–	60	μ s
	failure 6 recovery time	normal mode	150	–	750	μ s
	failures 4 and 7 detection time	normal mode	0.75	–	4.0	ms
	failures 4 and 7 recovery time	normal mode	10	–	60	μ s
	failures 3, 4 and 7 detection time	low power modes; $V_{BAT} = 12$ V	0.8	–	8.0	ms
	failures 3, 4 and 7 recovery time	low power modes; $V_{BAT} = 12$ V	–	4	–	ms
$t_{h(min)}$	minimum hold time to go to sleep command		5	–	50	μ s
Δ_{ec}	edge-count difference between CANH and CANL for failures 1, 2 and 5 detection (NERR becomes LOW)	normal mode	–	3	–	
	edge-count difference between CANH and CANL for failures 1, 2 and 5 recovery	normal mode	–	1	–	

Fault-tolerant CAN transceiver

PCA82C252

TEST AND APPLICATION INFORMATION

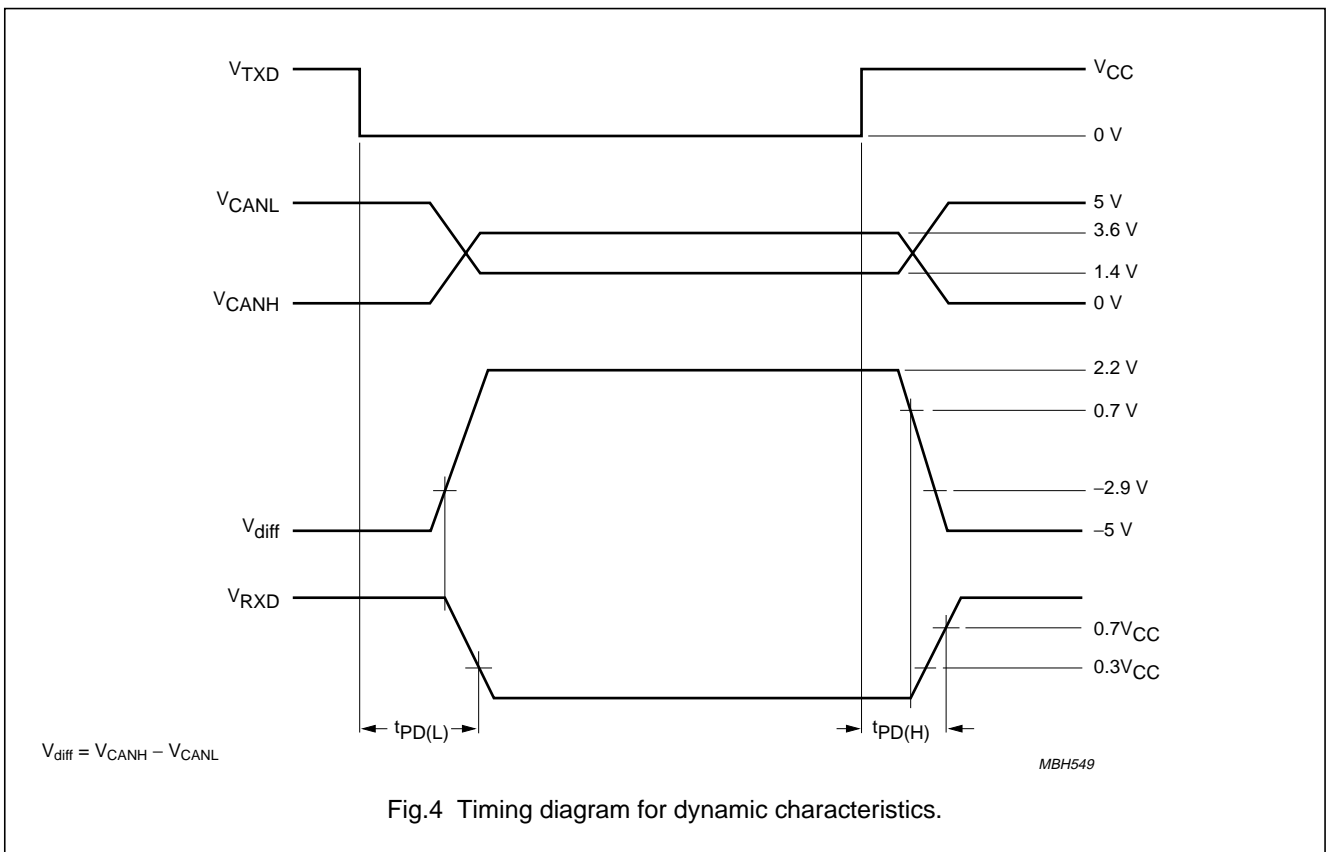
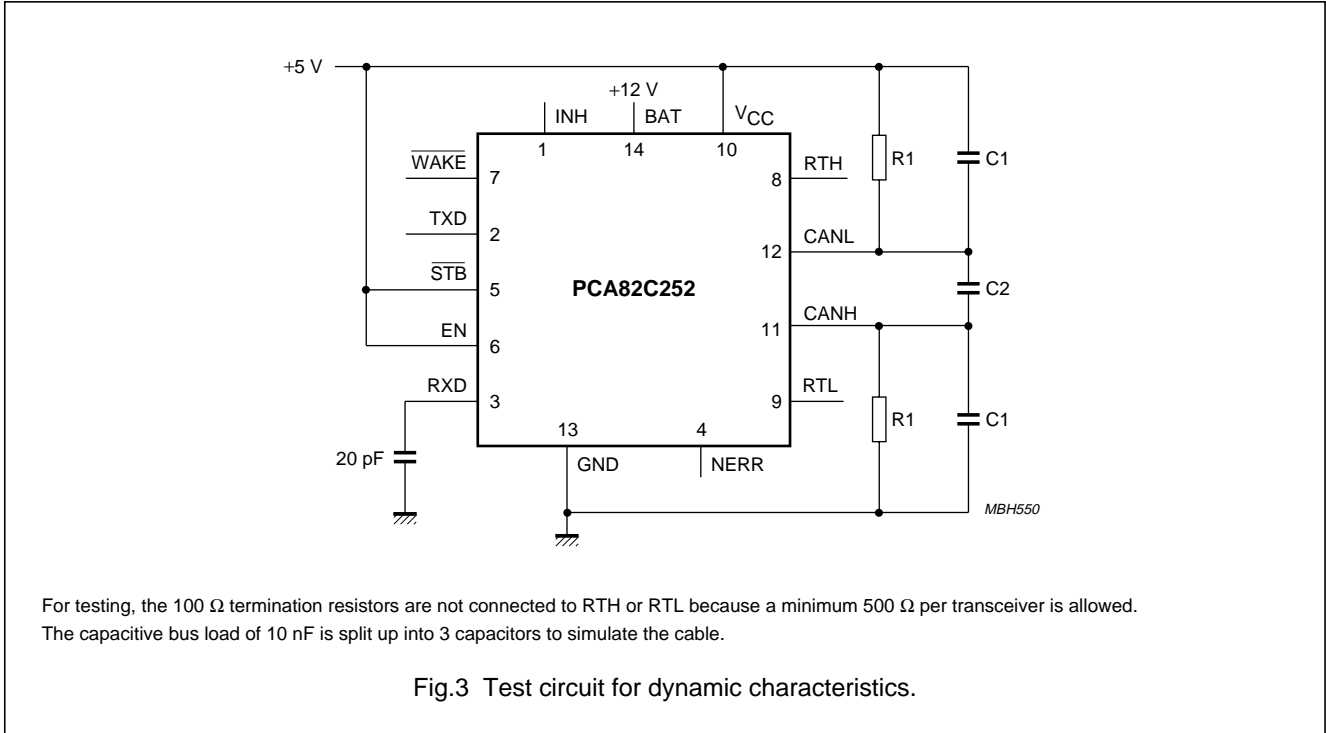

Fault-tolerant CAN transceiver

PCA82C252

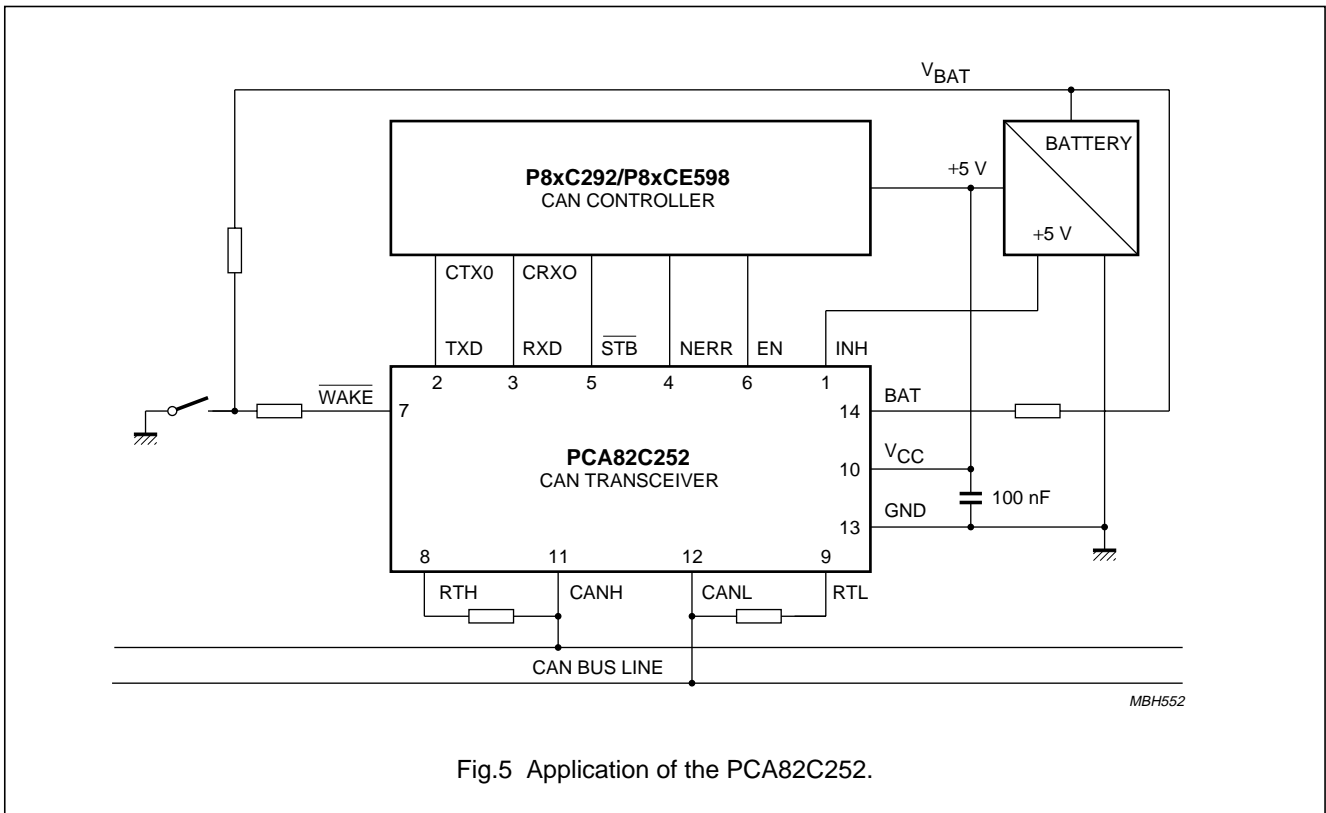
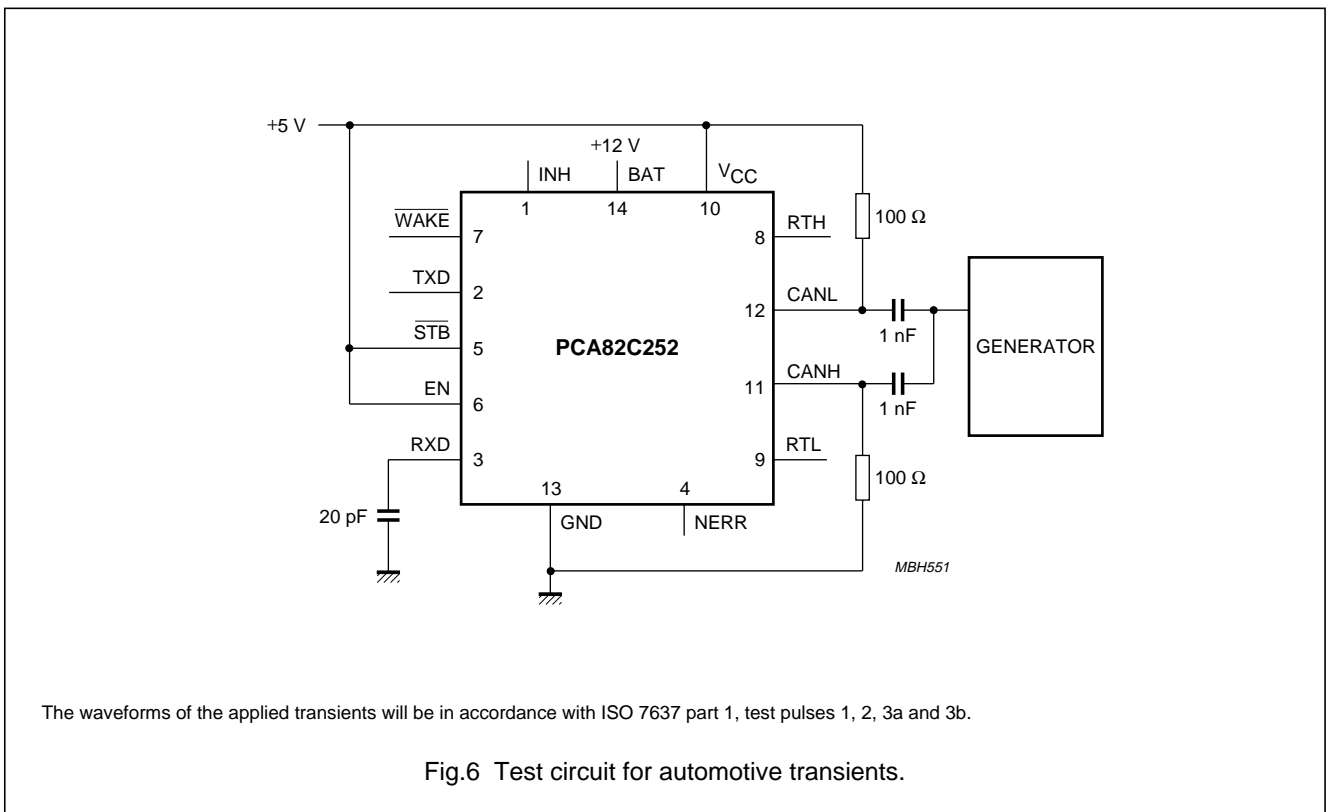

Fig.5 Application of the PCA82C252.



The waveforms of the applied transients will be in accordance with ISO 7637 part 1, test pulses 1, 2, 3a and 3b.

Fig.6 Test circuit for automotive transients.

Fault-tolerant CAN transceiver

PCA82C252

PACKAGE OUTLINE

SO14: plastic small outline package; 14 leads; body width 3.9 mm

SOT108-1

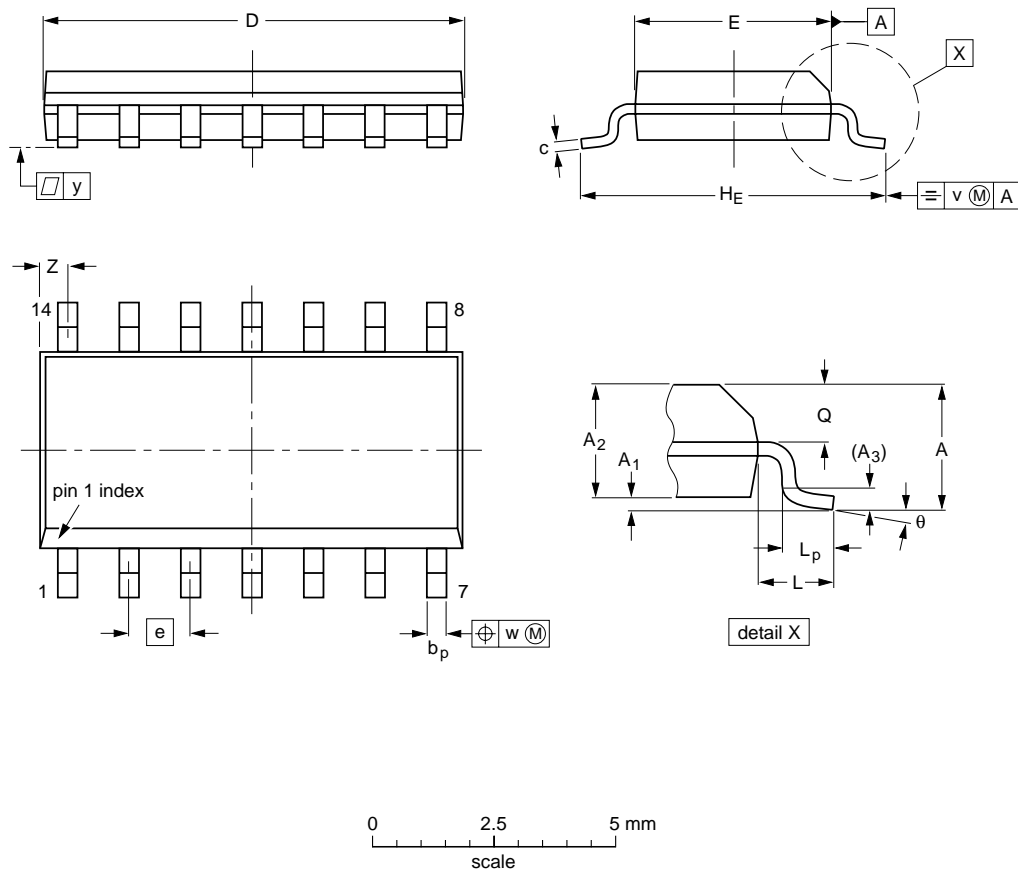

DIMENSIONS (inch dimensions are derived from the original mm dimensions)

UNIT	A max.	A ₁	A ₂	A ₃	b _p	c	D ⁽¹⁾	E ⁽¹⁾	e	H _E	L	L _p	Q	v	w	y	Z ⁽¹⁾	θ
mm	1.75	0.25 0.10	1.45 1.25	0.25	0.49 0.36	0.25 0.19	8.75 8.55	4.0 3.8	1.27	6.2 5.8	1.05	1.0 0.4	0.7 0.6	0.25	0.25	0.1	0.7 0.3	8° 0°
inches	0.069	0.010 0.004	0.057 0.049	0.01	0.019 0.014	0.0100 0.0075	0.35 0.34	0.16 0.15	0.050	0.244 0.228	0.041	0.039 0.016	0.028 0.024	0.01	0.01	0.004	0.028 0.012	

Note

1. Plastic or metal protrusions of 0.15 mm maximum per side are not included.

OUTLINE VERSION	REFERENCES				EUROPEAN PROJECTION	ISSUE DATE
	IEC	JEDEC	EIAJ			
SOT108-1	076E06S	MS-012AB				95-01-23 97-05-22

Fault-tolerant CAN transceiver

PCA82C252

SOLDERING

Introduction

There is no soldering method that is ideal for all IC packages. Wave soldering is often preferred when through-hole and surface mounted components are mixed on one printed-circuit board. However, wave soldering is not always suitable for surface mounted ICs, or for printed-circuits with high population densities. In these situations reflow soldering is often used.

This text gives a very brief insight to a complex technology. A more in-depth account of soldering ICs can be found in our "*IC Package Databook*" (order code 9398 652 90011).

Reflow soldering

Reflow soldering techniques are suitable for all SO packages.

Reflow soldering requires solder paste (a suspension of fine solder particles, flux and binding agent) to be applied to the printed-circuit board by screen printing, stencilling or pressure-syringe dispensing before package placement.

Several techniques exist for reflowing; for example, thermal conduction by heated belt. Dwell times vary between 50 and 300 seconds depending on heating method. Typical reflow temperatures range from 215 to 250 °C.

Preheating is necessary to dry the paste and evaporate the binding agent. Preheating duration: 45 minutes at 45 °C.

Wave soldering

Wave soldering techniques can be used for all SO packages if the following conditions are observed:

- A double-wave (a turbulent wave with high upward pressure followed by a smooth laminar wave) soldering technique should be used.
- The longitudinal axis of the package footprint must be parallel to the solder flow.
- The package footprint must incorporate solder thieves at the downstream end.

During placement and before soldering, the package must be fixed with a droplet of adhesive. The adhesive can be applied by screen printing, pin transfer or syringe dispensing. The package can be soldered after the adhesive is cured.

Maximum permissible solder temperature is 260 °C, and maximum duration of package immersion in solder is 10 seconds, if cooled to less than 150 °C within 6 seconds. Typical dwell time is 4 seconds at 250 °C.

A mildly-activated flux will eliminate the need for removal of corrosive residues in most applications.

Repairing soldered joints

Fix the component by first soldering two diagonally-opposite end leads. Use only a low voltage soldering iron (less than 24 V) applied to the flat part of the lead. Contact time must be limited to 10 seconds at up to 300 °C. When using a dedicated tool, all other leads can be soldered in one operation within 2 to 5 seconds between 270 and 320 °C.

Fault-tolerant CAN transceiver**PCA82C252**

DEFINITIONS

Data sheet status	
Objective specification	This data sheet contains target or goal specifications for product development.
Preliminary specification	This data sheet contains preliminary data; supplementary data may be published later.
Product specification	This data sheet contains final product specifications.
Limiting values	
Limiting values given are in accordance with the Absolute Maximum Rating System (IEC 134). Stress above one or more of the limiting values may cause permanent damage to the device. These are stress ratings only and operation of the device at these or at any other conditions above those given in the Characteristics sections of the specification is not implied. Exposure to limiting values for extended periods may affect device reliability.	
Application information	
Where application information is given, it is advisory and does not form part of the specification.	

LIFE SUPPORT APPLICATIONS

These products are not designed for use in life support appliances, devices, or systems where malfunction of these products can reasonably be expected to result in personal injury. Philips customers using or selling these products for use in such applications do so at their own risk and agree to fully indemnify Philips for any damages resulting from such improper use or sale.

Fault-tolerant CAN transceiver

PCA82C252

NOTES

Fault-tolerant CAN transceiver

PCA82C252

NOTES

Fault-tolerant CAN transceiver

PCA82C252

NOTES

Philips Semiconductors – a worldwide company

Argentina: see South America

Australia: 34 Waterloo Road, NORTH RYDE, NSW 2113,
Tel. +61 2 9805 4455, Fax. +61 2 9805 4466

Austria: Computerstr. 6, A-1101 WIEN, P.O. Box 213, Tel. +43 160 1010,
Fax. +43 160 101 1210

Belarus: Hotel Minsk Business Center, Bld. 3, r. 1211, Volodarski Str. 6,
220050 MINSK, Tel. +375 172 200 733, Fax. +375 172 200 773

Belgium: see The Netherlands

Brazil: see South America

Bulgaria: Philips Bulgaria Ltd., Energoproject, 15th floor,
51 James Bourchier Blvd., 1407 SOFIA,
Tel. +359 2 689 211, Fax. +359 2 689 102

Canada: PHILIPS SEMICONDUCTORS/COMPONENTS,
Tel. +1 800 234 7381

China/Hong Kong: 501 Hong Kong Industrial Technology Centre,
72 Tat Chee Avenue, Kowloon Tong, HONG KONG,
Tel. +852 2319 7888, Fax. +852 2319 7700

Colombia: see South America

Czech Republic: see Austria

Denmark: Prags Boulevard 80, PB 1919, DK-2300 COPENHAGEN S,
Tel. +45 32 88 2636, Fax. +45 31 57 0044

Finland: Sinikalliontie 3, FIN-02630 ESPOO,
Tel. +358 9 615800, Fax. +358 9 61580920

France: 4 Rue du Port-aux-Vins, BP317, 92156 SURESNES Cedex,
Tel. +33 1 40 99 6161, Fax. +33 1 40 99 6427

Germany: Hammerbrookstraße 69, D-20097 HAMBURG,
Tel. +49 40 23 53 60, Fax. +49 40 23 536 300

Greece: No. 15, 25th March Street, GR 17778 TAVROS/ATHENS,
Tel. +30 1 4894 339/239, Fax. +30 1 4814 240

Hungary: see Austria

India: Philips INDIA Ltd, Band Box Building, 2nd floor,
254-D, Dr. Annie Besant Road, Worli, MUMBAI 400 025,
Tel. +91 22 493 8541, Fax. +91 22 493 0966

Indonesia: see Singapore

Ireland: Newstead, Clonskeagh, DUBLIN 14,
Tel. +353 1 7640 000, Fax. +353 1 7640 200

Israel: RAPAC Electronics, 7 Kehilat Saloniki St, PO Box 18053,
TEL AVIV 61180, Tel. +972 3 645 0444, Fax. +972 3 649 1007

Italy: PHILIPS SEMICONDUCTORS, Piazza IV Novembre 3,
20124 MILANO, Tel. +39 2 6752 2531, Fax. +39 2 6752 2557

Japan: Philips Bldg 13-37, Kohnan 2-chome, Minato-ku, TOKYO 108,
Tel. +81 3 3740 5130, Fax. +81 3 3740 5077

Korea: Philips House, 260-199 Itaewon-dong, Yongsan-ku, SEOUL,
Tel. +82 2 709 1412, Fax. +82 2 709 1415

Malaysia: No. 76 Jalan Universiti, 46200 PETALING JAYA, SELANGOR,
Tel. +60 3 750 5214, Fax. +60 3 757 4880

Mexico: 5900 Gateway East, Suite 200, EL PASO, TEXAS 79905,
Tel. +9-5 800 234 7381

Middle East: see Italy

Netherlands: Postbus 90050, 5600 PB EINDHOVEN, Bldg. VB,
Tel. +31 40 27 82785, Fax. +31 40 27 88399

New Zealand: 2 Wagener Place, C.P.O. Box 1041, AUCKLAND,
Tel. +64 9 849 4160, Fax. +64 9 849 7811

Norway: Box 1, Manglerud 0612, OSLO,
Tel. +47 22 74 8000, Fax. +47 22 74 8341

Philippines: Philips Semiconductors Philippines Inc.,
106 Valero St. Salcedo Village, P.O. Box 2108 MCC, MAKATI,
Metro MANILA, Tel. +63 2 816 6380, Fax. +63 2 817 3474

Poland: Ul. Lukiska 10, PL 04-123 WARSZAWA,
Tel. +48 22 612 2831, Fax. +48 22 612 2327

Portugal: see Spain

Romania: see Italy

Russia: Philips Russia, Ul. Usatcheva 35A, 119048 MOSCOW,
Tel. +7 095 755 6918, Fax. +7 095 755 6919

Singapore: Lorong 1, Toa Payoh, SINGAPORE 1231,
Tel. +65 350 2538, Fax. +65 251 6500

Slovakia: see Austria

Slovenia: see Italy

South Africa: S.A. PHILIPS Pty Ltd., 195-215 Main Road Martindale,
2092 JOHANNESBURG, P.O. Box 7430 Johannesburg 2000,
Tel. +27 11 470 5911, Fax. +27 11 470 5494

South America: Rua do Rocio 220, 5th floor, Suite 51,
04552-903 São Paulo, SÃO PAULO - SP, Brazil,
Tel. +55 11 821 2333, Fax. +55 11 829 1849

Spain: Balmes 22, 08007 BARCELONA,
Tel. +34 3 301 6312, Fax. +34 3 301 4107

Sweden: Kottbygatan 7, Akalla, S-16485 STOCKHOLM,
Tel. +46 8 632 2000, Fax. +46 8 632 2745

Switzerland: Allmendstrasse 140, CH-8027 ZÜRICH,
Tel. +41 1 488 2686, Fax. +41 1 481 7730

Taiwan: Philips Semiconductors, 6F, No. 96, Chien Kuo N. Rd., Sec. 1,
TAIPEI, Taiwan Tel. +886 2 2134 2865, Fax. +886 2 2134 2874

Thailand: PHILIPS ELECTRONICS (THAILAND) Ltd.,
209/2 Sanpavuth-Bangna Road Prakanong, BANGKOK 10260,
Tel. +66 2 745 4090, Fax. +66 2 398 0793

Turkey: Talatpasa Cad. No. 5, 80640 GÜLTEPE/ISTANBUL,
Tel. +90 212 279 2770, Fax. +90 212 282 6707

Ukraine: PHILIPS UKRAINE, 4 Patrice Lumumba str., Building B, Floor 7,
252042 KIEV, Tel. +380 44 264 2776, Fax. +380 44 268 0461

United Kingdom: Philips Semiconductors Ltd., 276 Bath Road, Hayes,
MIDDLESEX UB3 5BX, Tel. +44 181 730 5000, Fax. +44 181 754 8421

United States: 811 East Arques Avenue, SUNNYVALE, CA 94088-3409,
Tel. +1 800 234 7381

Uruguay: see South America

Vietnam: see Singapore

Yugoslavia: PHILIPS, Trg N. Pasica 5/v, 11000 BEOGRAD,
Tel. +381 11 625 344, Fax. +381 11 635 777

For all other countries apply to: Philips Semiconductors, Marketing & Sales Communications,
Building BE-p, P.O. Box 218, 5600 MD EINDHOVEN, The Netherlands, Fax. +31 40 27 24825

Internet: <http://www.semiconductors.philips.com>

© Philips Electronics N.V. 1997

SCA55

All rights are reserved. Reproduction in whole or in part is prohibited without the prior written consent of the copyright owner.

The information presented in this document does not form part of any quotation or contract, is believed to be accurate and reliable and may be changed without notice. No liability will be accepted by the publisher for any consequence of its use. Publication thereof does not convey nor imply any license under patent- or other industrial or intellectual property rights.

Printed in The Netherlands

897027/00/04/pp20

Date of release: 1997 Oct 28

Document order number: 9397 750 02969

Let's make things better.

**Philips
Semiconductors**



PHILIPS