

DATA SHEET

TEA1069; TEA1069A

Versatile speech/dialler/ringer with
music-on-hold

Product specification
Supersedes data of 1996 Dec 10
File under Integrated Circuits, IC03

1998 Jan 08

Versatile speech/dialler/ringer with music-on-hold

TEA1069; TEA1069A

FEATURES

Speech part

- Voltage regulator with adjustable static resistance
- Low DC line voltage; operates down to 1.6 V (excluding polarity guard)
- Supply for dialler part and peripherals (not stabilized)
- Symmetrical high-impedance inputs (64 k Ω) for dynamic, magnetic, or piezoelectric microphones
- Asymmetrical high-impedance input (32 k Ω) for electret microphones
- Asymmetrical earpiece output for dynamic, magnetic, or piezoelectric earpieces
- Internal mute to disable speech during dialling
- Confidence tone during DTMF dialling
- Line-loss compensation (line-current dependent) for microphone and earpiece amplifiers
- Gain-control curve adaptable to the exchange supply.

Dialler part

- Pulse/DTMF and mixed mode dialling
- Last Number Redial (LNR), up to 32 digits
- 13 repertory numbers (3 direct and 10 indirect) or 10 repertory numbers (10 direct), up to 32 digits, with a maximum of 224 digits in total
- Repertory and redial memory integrity check (memory contents check)
- Notepad memory function
- Flash and earth register recall
- Dial mode output
- Access pause generation and termination
- Function keys for: store, memory recall, register recall, LNR, pause, hold, mute, hook
- Keytone generation
- Hands-free control
- Volume control in hands-free mode (VOL+/VOL-)
- Hold function
- Mute function
- Music-on-hold
- Diode options:
 - DTMF tone burst/pause time
 - make/break ratio
 - access pause time

- pulse or DTMF mode selection
- register recall (earth and flash times)
- keyboard layout selection
- selection for german requirements
- hold/mute mode selection.

Ringer part

- Ringer input frequency discrimination
- Ringer melody generation (3-tone)
- Ringer melody selection/volume control via keyboard
- Diode option: ringer frequency selection.

GENERAL DESCRIPTION

The TEA1069 and TEA1069A contain all the functions needed to build a highly featured, high-performance fully electronic telephone set.

The device incorporates a speech/transmission part, a dialler part and a ringer part. By offering a wide range of possible adaptations for each part, the TEA1069 and TEA1069A application can be easily adapted to meet different requirements.

The TEA1069A offers some different timings and diode options compared to the TEA1069.

Where pin numbers are mentioned in this data sheet we refer to the TEA1069N, unless otherwise indicated.

Speech part

The speech/transmission part performs all speech and line interface functions required in electronic sets. It operates at line voltages down to 1.6 V DC to facilitate the use of more telephones connected in parallel.

Dialler part

The dialler part offers a 32-digit Last Number Redial (LNR) and 13 memories. Hands-free control is included allowing the TEA1069 and TEA1069A to be used not only in basic telephones, but also in feature phones offering hands-free dialling via the TEA1083 call-progress monitor IC and/or full hands-free operation via the TEA1093 hands-free IC. The hold function allows the user to suspend the conversation and resume the call either on the same phone or on a parallel phone. Additionally through the music-on-hold function a melody is transmitted while the set is put on hold. The keytones provide in a buzzer an audible feedback of a valid key pressed.

Versatile speech/dialler/ringer with music-on-hold

TEA1069; TEA1069A

Ringer part

The ringer part offers a discriminator input which enables the tone output as soon as a valid ring frequency is detected. It offers a melody based on 3 tones with programmable melody and volume via keyboard.

ORDERING INFORMATION

TYPE NUMBER	PACKAGE		
	NAME	DESCRIPTION	VERSION
TEA1069N	SDIP42	plastic shrink dual in-line package; 42 leads (600 mil)	SOT270-1
TEA1069H	QFP44	plastic quad flat package; 44 leads (lead length 1.3 mm); body 10 × 10 × 1.75 mm	SOT307-2
TEA1069AH	QFP44	plastic quad flat package; 44 leads (lead length 1.3 mm); body 10 × 10 × 1.75 mm	SOT307-2

Versatile speech/dialler/ringer with music-on-hold

TEA1069; TEA1069A

BLOCK DIAGRAM

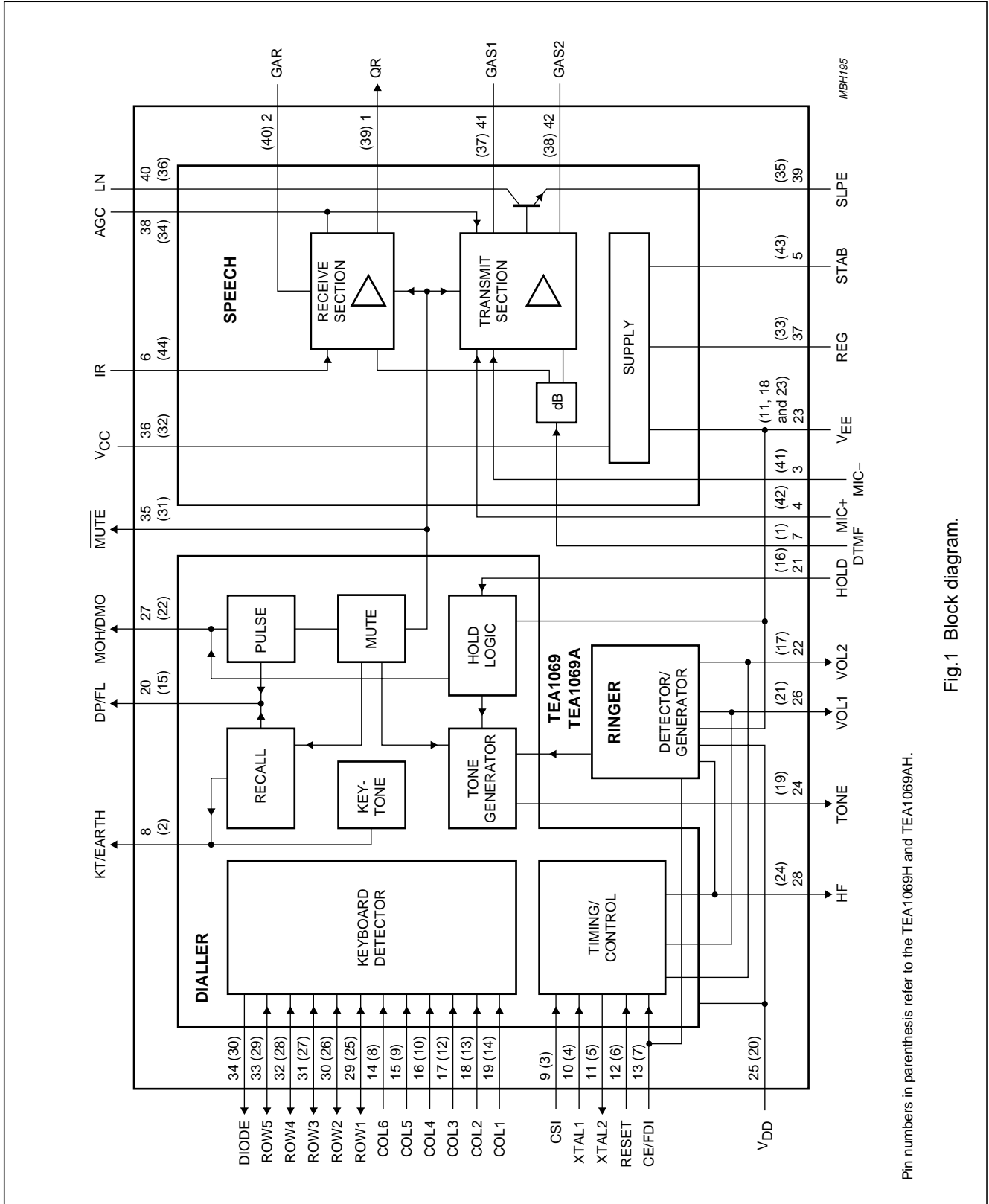

Fig.1 Block diagram.

Pin numbers in parenthesis refer to the TEA1069H and TEA1069AH.

Versatile speech/dialler/ringer with music-on-hold

TEA1069; TEA1069A

PINNING

SYMBOL	PIN		DESCRIPTION
	SOT270-1	SOT307-2	
QR	1	39	receiving amplifier output
GAR	2	40	gain adjustment; receiving amplifier
MIC-	3	41	inverting microphone input
MIC+	4	42	non-inverting microphone input
STAB	5	43	current stabilizer
IR	6	44	receiving amplifier input
DTMF	7	1	dual-tone multi-frequency input
KT/EARTH	8	2	keytone/earth recall output
CSI	9	3	cradle switch input
XTAL1	10	4	oscillator input
XTAL2	11	5	oscillator output
RESET	12	6	reset input
CE/FDI	13	7	chip enable/frequency discrimination input
COL6	14	8	keyboard column input 6
COL5	15	9	keyboard column input 5
COL4	16	10	keyboard column input 4
COL3	17	12	keyboard column input 3
COL2	18	13	keyboard column input 2
COL1	19	14	keyboard column input 1
DP/FL	20	15	dial pulse/flash output
HOLD	21	16	hold control input
VOL2	22	17	volume 2 output
V _{EE}	23	11, 18, 23	negative line terminal
TONE	24	19	tone generator output
V _{DD}	25	20	dialler/ringer part supply voltage
VOL1	26	21	volume 1 output
MOH/DMO	27	22	music on hold/dial mode output
HF	28	24	hands-free control output
ROW1	29	25	keyboard row input/output 1
ROW2	30	26	keyboard row input/output 2
ROW3	31	27	keyboard row input/output 3
ROW4	32	28	keyboard row input/output 4
ROW5	33	29	keyboard row input/output 5
DIODE	34	30	diode option output
MUTE	35	31	mute output, active LOW
V _{CC}	36	32	speech part supply voltage
REG	37	33	(DC) line voltage regulator decoupling
AGC	38	34	automatic gain control input

Versatile speech/dialler/ringer with music-on-hold

TEA1069; TEA1069A

SYMBOL	PIN		DESCRIPTION
	SOT270-1	SOT307-2	
SLPE	39	35	slope (DC resistance) adjustment
LN	40	36	positive line terminal
GAS1	41	37	gain adjustment; transmitting amplifier
GAS2	42	38	gain adjustment; transmitting amplifier

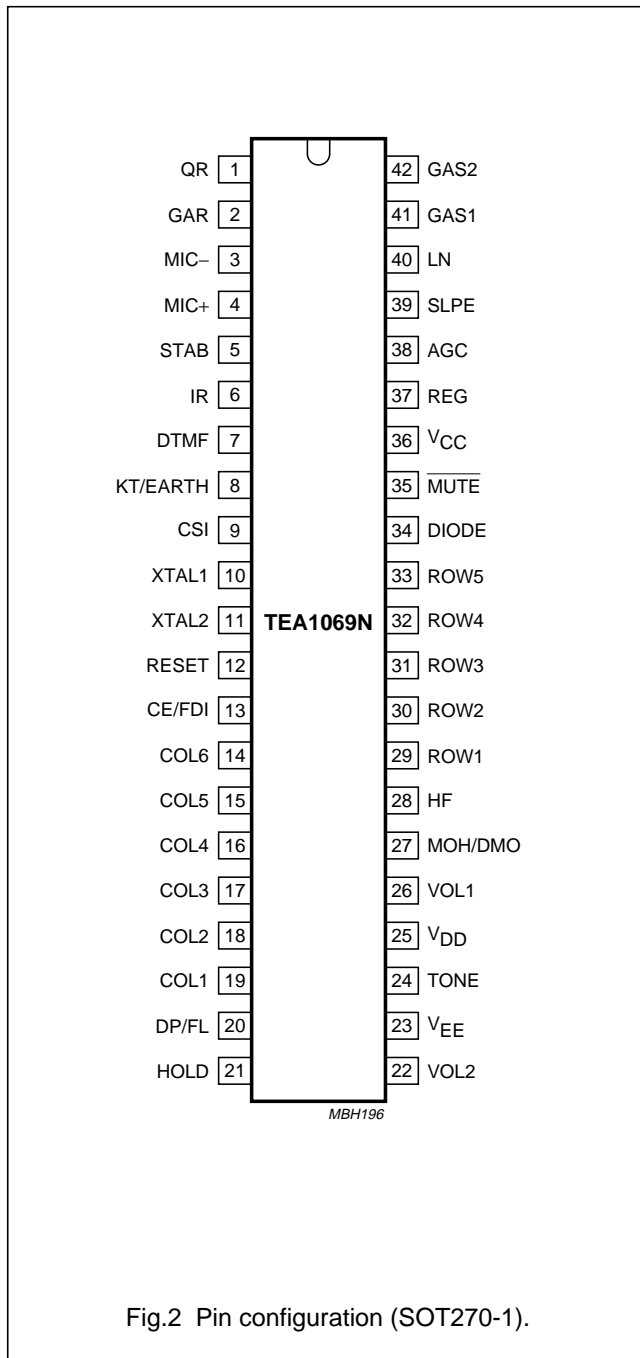

Versatile speech/dialler/ringer with music-on-hold

TEA1069; TEA1069A

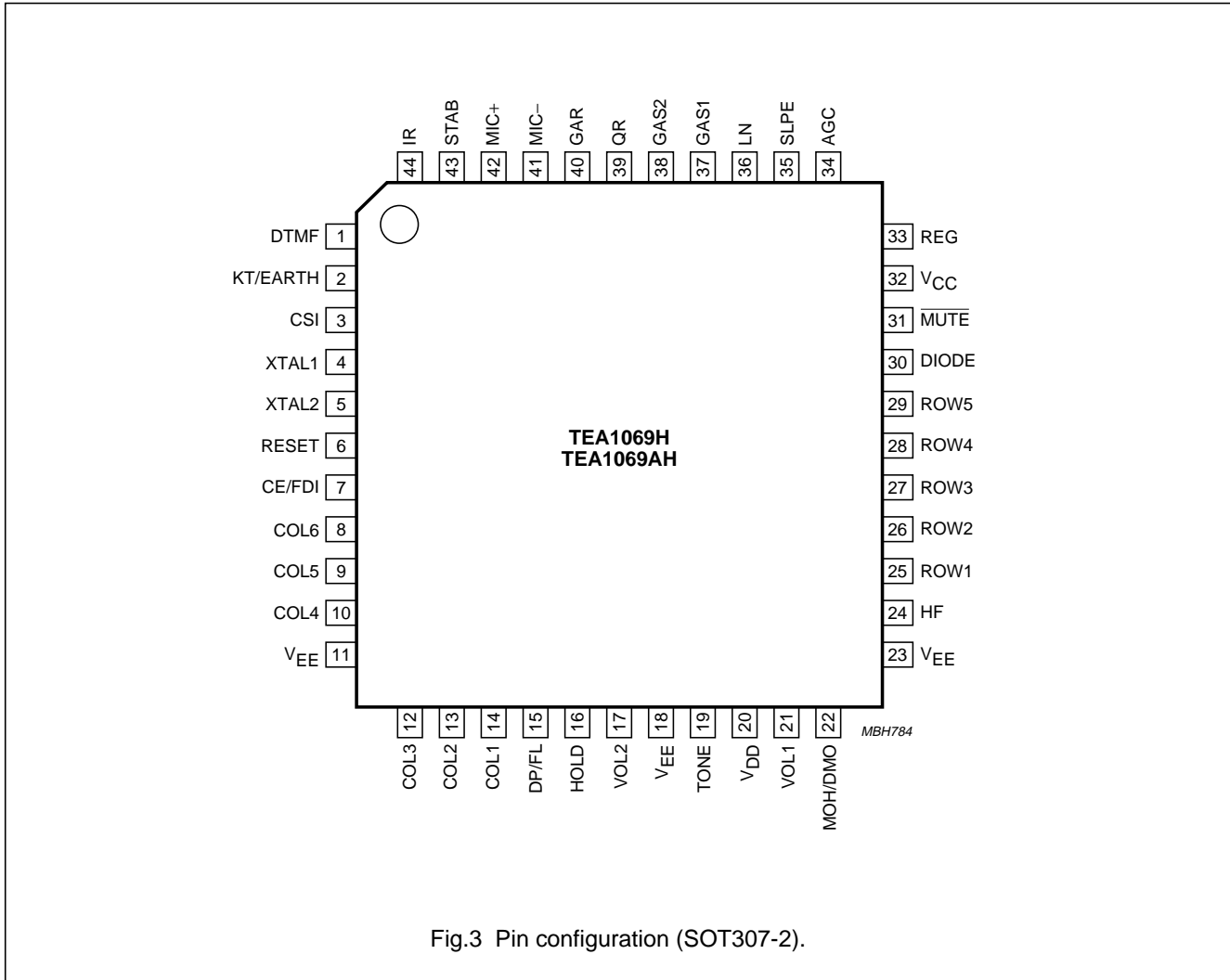

Fig.3 Pin configuration (SOT307-2).

FUNCTIONAL DESCRIPTION

Speech part

For numbering of components refer to Figs 28 and 29.

SUPPLIES V_{CC} , LN, SLPE, REG AND STAB

Power for the IC and its peripheral circuits is usually obtained from the telephone line (see Fig.4).

The circuit creates a stabilized voltage ($V_{ref} = 3.7 V$) between LN and SLPE. This reference voltage is temperature compensated and can be adjusted by means of an external resistor R_{VA} . It can be increased by connecting an R_{VA} resistor (R60) between REG and SLPE or decreased by connecting an R_{VA} resistor (R61) between REG and LN. This internal voltage reference is decoupled by capacitor C3 between REG and V_{EE} .

This decoupling capacitor realises the set impedance conversion from its DC value to its AC value in the audio frequency range.

The internal transmission part of the circuitry (including the earpiece amplifier) is supplied from V_{CC} . This voltage supply is derived from the LN voltage via a dropping resistor (R1) and must be decoupled by a capacitor (C1) between V_{CC} and V_{EE} . This supply point may also be used to supply the dialler/ringer (V_{DD}) part or external circuit e.g. electret microphone.

The DC current flowing into the set is determined by the exchange supply voltage V_{exch} , the feeding bridge resistance R_{exch} and the DC resistance of the telephone line R_{line} . When the line current (I_{line}) is more than 0.5 mA greater than the sum of the IC supply current (I_{CC}) and the current drawn by the peripheral circuitry connected to V_{CC} (I_p), the excess current is shunted to SLPE via LN.

Versatile speech/dialler/ringer with music-on-hold

TEA1069; TEA1069A

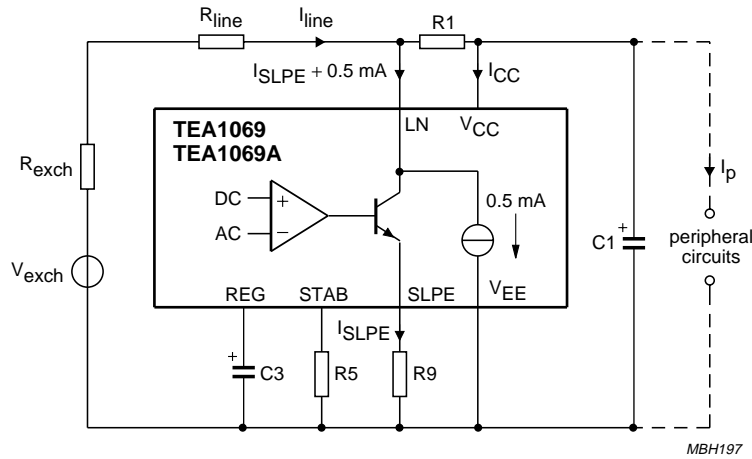

Fig.4 Supply arrangement.

Thus, the regulated voltage on the line terminal (V_{LN}) can be calculated as:

$$V_{LN} = V_{ref} + I_{SLPE} \times R9, \text{ where}$$

$$I_{SLPE} = I_{line} - (I_{CC} + I_p + 0.5 \times 10^{-3} \text{ A})$$

V_{ref} is the internally generated temperature compensated reference voltage of 3.7 V and R9 is an external resistor connected between SLPE and V_{EE} .

The circuit has an internal current stabilizer operating at a level determined by resistor R5 connected between STAB and V_{EE} .

In normal use the value of R5 would be 3.6 k Ω and the value of R9 would be 20 Ω .

Changing the value of R5 or R9 will affect microphone gain, DTMF gain, gain control characteristics, sidetone level, maximum output swing on LN and the DC characteristics (especially at low line current).

At line currents below 9 mA the internal reference voltage is automatically adjusted to a lower value (typically 1.6 V

at 1 mA). This means that more sets can be operated in parallel with DC line voltages (excluding the polarity guard) down to an absolute minimum voltage of 1.6 V. At line currents below 9 mA the circuit has limited sending and receiving levels.

Under normal conditions, when $I_{SLPE} \gg I_{CC} + 0.5 \text{ mA} + I_p$, the static behaviour of the circuit is that of a 3.7 V regulator diode (V_{ref}) with an internal resistance equal to that of R9. In the audio frequency range the dynamic impedance is largely determined by R1. Figure 5 shows the equivalent impedance of the circuit.

Current (I_p) available from V_{CC} for the dialler part and peripheral circuits depends on the external components used. Figure 6 shows this current for $V_{CC} > 2.2 \text{ V}$. When \overline{MUTE} is HIGH i.e. when the receiving amplifier (supplied from V_{CC}) is driven, the available current is further reduced. Current availability can be increased by connecting the supply IC TEA1081 in parallel with R1, or by increasing the DC line voltage by means of an external resistor ($R_{VA} = R60$) connected between REG and SLPE.

Versatile speech/dialler/ringer with music-on-hold

TEA1069; TEA1069A

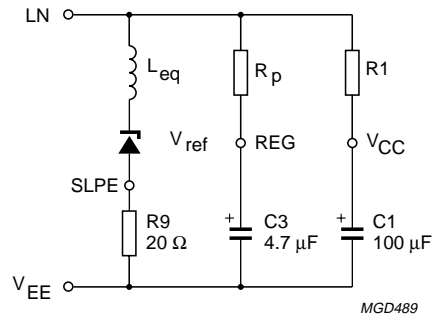

$L_{eq} = C3 \times R9 \times R_p$
 $R_p = 16.2 \text{ k}\Omega$

Fig.5 Equivalent impedance circuit.

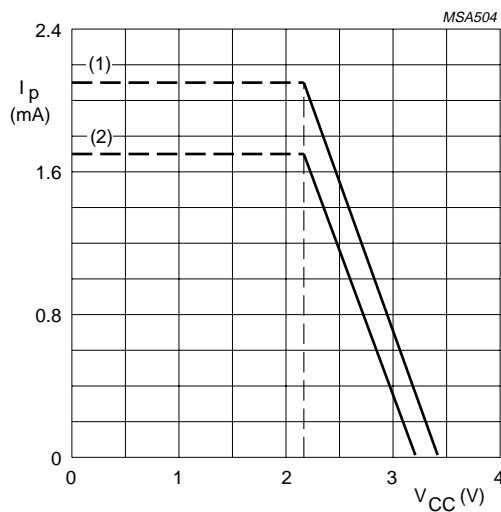

$V_{CC} > 2.2 \text{ V}$; $I_{line} = 15 \text{ mA}$ at $V_{LN} = 4 \text{ V}$; $R_1 = 620 \Omega$; $R_9 = 20 \Omega$.

(1) $I_p = 2.1 \text{ mA}$. The curve is valid when the receiving amplifier is not driven or when $\overline{MUTE} = \text{LOW}$.

(2) $I_p = 1.7 \text{ mA}$. The curve is valid when $\overline{MUTE} = \text{HIGH}$ and the receiving amplifier is driven; $V_{o(rms)} = 150 \text{ mV}$, $R_L = 150 \Omega$.

Fig.6 Typical current I_p available from V_{CC} for peripheral circuitry.

Versatile speech/dialler/ringer with music-on-hold

TEA1069; TEA1069A

MICROPHONE INPUTS MIC+ AND MIC- AND GAIN PINS GAS1 AND GAS2

The circuit has symmetrical microphone inputs. Its input impedance is 64 kΩ (2 × 32 kΩ) and its voltage gain is typically 52 dB (when R7 = 68 kΩ). Dynamic, magnetic, piezoelectric or electret (with built-in FET source followers) microphones can be used. Microphone arrangements are illustrated in Fig.7.

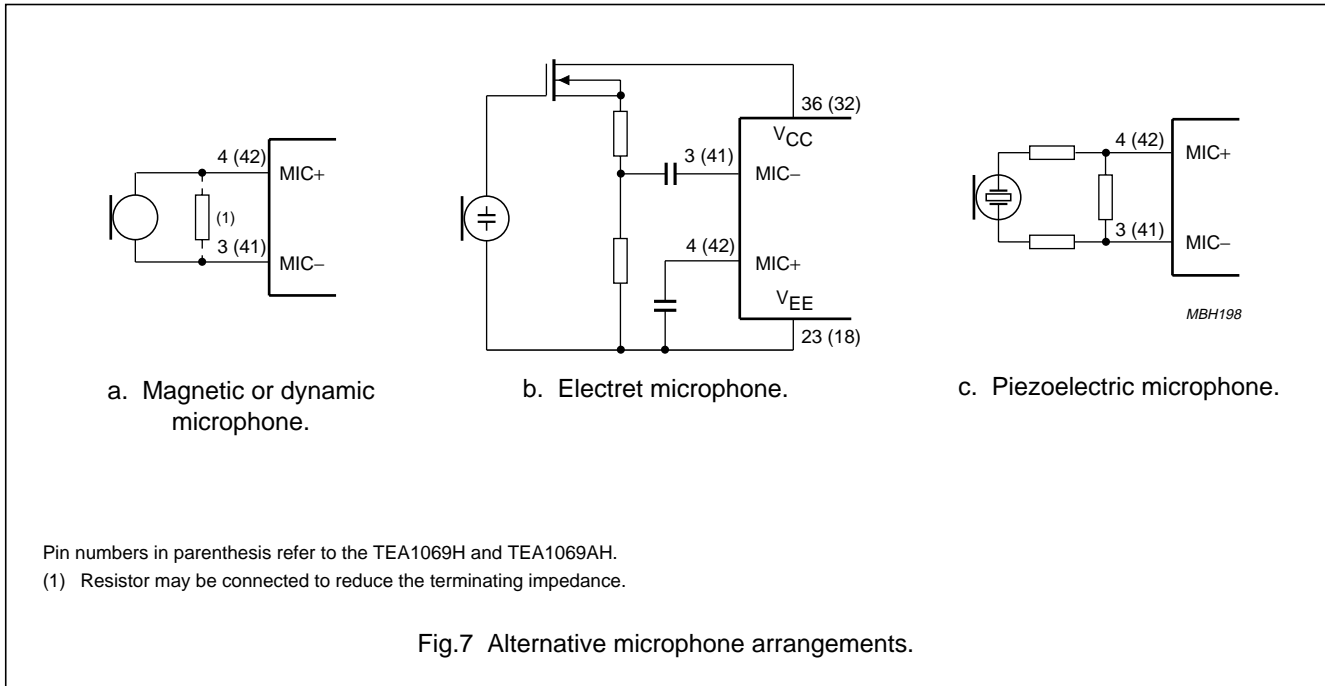

The gain of the microphone amplifier can be adjusted between 44 dB and 52 dB to suit the sensitivity of the transducer in use. The gain is proportional to the value of R7 which is connected between GAS1 and GAS2. Stability is ensured by two external capacitors, C6 connected between GAS1 and SLPE and C17 connected between GAS1 and VEE. The value of C6 is 100 pF but this may be increased to obtain a first-order low-pass filter. The value of C17 is 10 times the value of C6. The cut-off frequency corresponds to the time constant R7 × C6.

RECEIVING AMPLIFIER IR, QR AND GAR

The receiving amplifier has one input (IR) and one output (QR). Earpiece arrangements are illustrated in Fig.8. The IR to QR gain is typically 31 dB (when R4 = 100 kΩ).

It can be adjusted between 20 and 31 dB to match the sensitivity of the transducer in use.

The gain is set with the value of R4 which is connected between GAR and QR. The overall receive gain, between LN and QR, is calculated by subtracting the anti-sidetone network attenuation (32 dB) from the amplifier gain. Two external capacitors, C4 and C7, ensure stability. C4 is normally 100 pF and C7 is 10 times the value of C4. The value of C4 may be increased to obtain a first-order low-pass filter. The cut-off frequency will depend on the time constant R4 × C4.

The output voltage of the receiving amplifier is specified for continuous-wave drive. The maximum output voltage will be higher under speech conditions where the peak to RMS ratio is higher.

Versatile speech/dialler/ringer with music-on-hold

TEA1069; TEA1069A

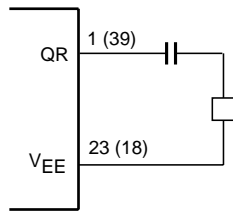

a. Dynamic earpiece.

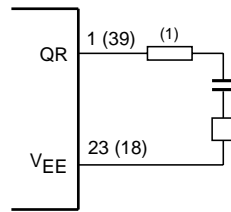

b. Magnetic earpiece.

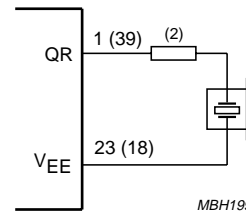

c. Piezoelectric earpiece.

Pin numbers in parenthesis refer to the TEA1069H and TEA1069AH.

(1) Resistor may be connected to prevent distortion (inductive load).

(2) Resistor is required to increase the phase margin (capacitive load).

Fig.8 Alternative receiver arrangements.

DUAL TONE MULTI-FREQUENCY INPUT DTMF

When the DTMF input is enabled ($\overline{\text{MUTE}}$ is LOW) dialling tones may be sent on to the line. The voltage gain from DTMF to LN is typically 25.5 dB (when $R7 = 68 \text{ k}\Omega$) and varies with $R7$ in the same way as the microphone gain. The tones can be heard in the earpiece at a low level (confidence tone).

AUTOMATIC GAIN CONTROL INPUT AGC

Automatic line loss compensation is achieved by connecting a resistor ($R6$) between AGC and V_{EE} . The automatic gain control varies the gain of the

microphone amplifier and the receiving amplifier in accordance with the DC line current.

The control range is 5.8 dB which corresponds to a line length of 5 km for a 0.5 mm diameter twisted-pair copper cable with a DC resistance of $176 \Omega/\text{km}$ and average attenuation of 1.2 dB/km. Resistor $R6$ should be chosen in accordance with the exchange supply voltage and its feeding bridge resistance (see Fig.9 and Table 1).

The ratio of start and stop currents of the AGC curve is independent of the value of $R6$. If no automatic line-loss compensation is required the AGC pin may be left open-circuit. The amplifiers, in this condition, will give their maximum specified gain.

Versatile speech/dialler/ringer with music-on-hold

TEA1069; TEA1069A

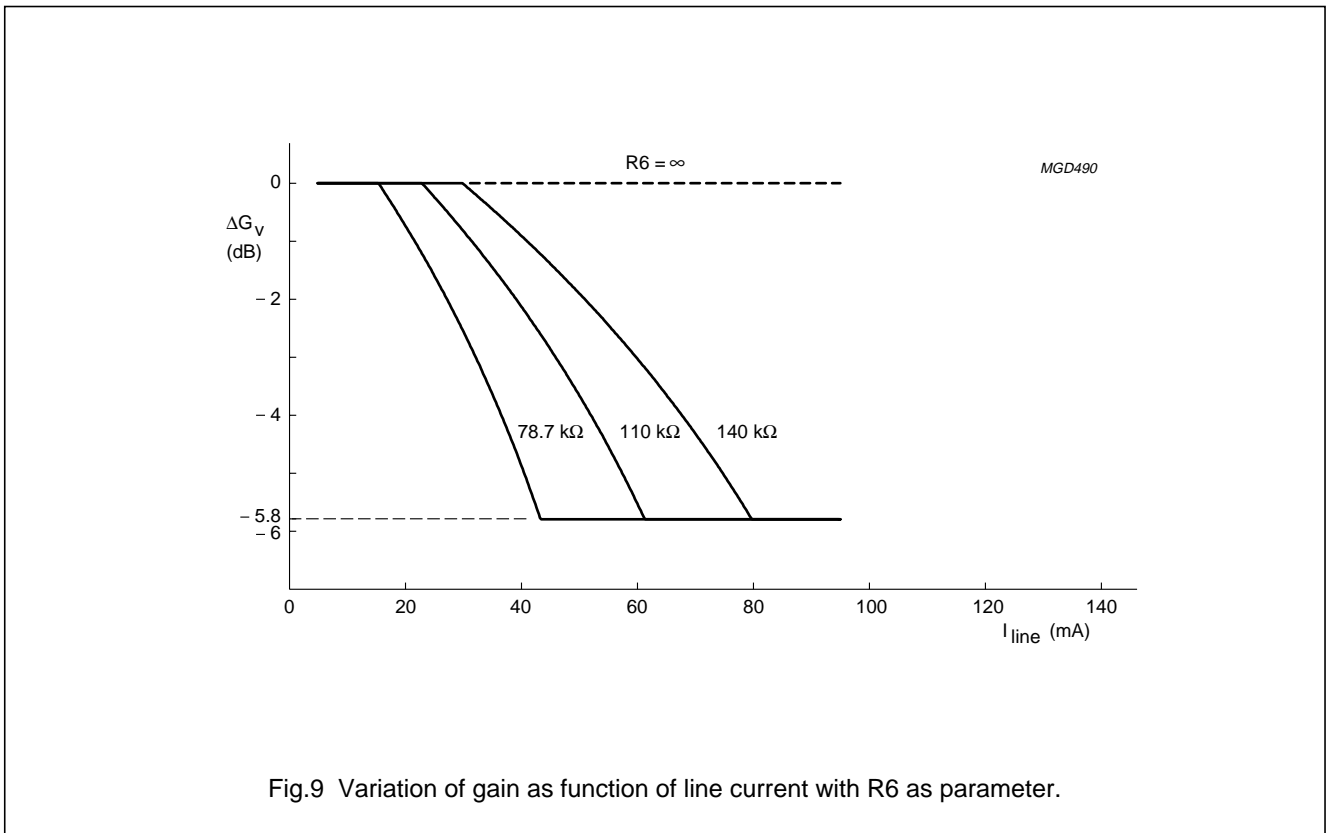

Table 1 Values of resistor R6 for optimum line-loss compensation at various values of exchange supply voltage (V_{exch}) and exchange feeding bridge resistance (R_{exch}); $R_9 = 20 \Omega$

V_{exch} (V)	R6 (kΩ)			
	$R_{exch} = 400 \Omega$	$R_{exch} = 600 \Omega$	$R_{exch} = 800 \Omega$	$R_{exch} = 1000 \Omega$
36	100	78.7	–	–
48	140	110	93.1	82
60	–	–	120	102

Versatile speech/dialler/ringer with music-on-hold

TEA1069; TEA1069A

SIDETONE SUPPRESSION

Suppression of the transmitted signal in the earpiece is obtained by the anti-sidetone network comprising R1//Z_{line}, R2, R3, R8, R9 and Z_{bal} (see Fig.10). The maximum compensation is obtained when the following conditions are fulfilled:

$$R9 \times R2 = R1 \times (R3 + R8) \tag{1}$$

$$k = R3 \times \frac{(R8 + R9)}{(R2 \times R9)} \tag{2}$$

$$Z_{bal} = k \times Z_{line} \tag{3}$$

The scale factor k is chosen to meet the compatibility with a standard capacitor from the E6 or E12 series for Z_{line}. In practice, Z_{line} varies considerably with the line type and length. Therefore, the value chosen for Z_{bal} should be for an average line length thus giving optimum setting for short or long lines.

Example: the balance impedance Z_{bal} at which the optimum suppression is present can be calculated as

follows:

suppose Z_{line} = 210 Ω + (1265 Ω//140 nF) representing a 5 km line of 0.5 mm diameter, copper, twisted-pair cable matched to 600 Ω (176 Ω/km; 38 nF/km).

When k = 0.64 then R8 = 390 Ω;

Z_{bal} = 130 Ω + (820 Ω//220 nF).

The anti-sidetone network for the TEA1069 and TEA1069A shown in Fig.10 attenuates the signal received from the line by 32 dB before it enters the receiving amplifier.

The attenuation is almost constant over the whole audio-frequency range. Figure 11 shows a conventional Wheatstone bridge anti-sidetone circuit that can be used as an alternative. Both bridge types can be used with either resistive or complex set impedances. More information on the balancing of anti-sidetone bridges can be found in our publication "Applications Handbook for Wired telecom systems, IC03b", order number 9397 750 00811.

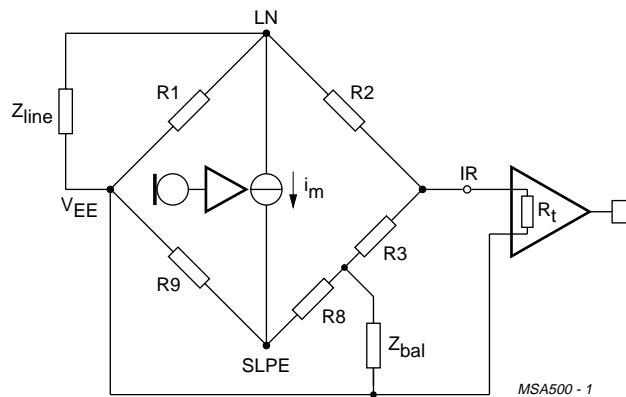

Fig.10 Equivalent circuit of TEA1069 and TEA1069A anti-sidetone bridge.

Versatile speech/dialler/ringer with music-on-hold

TEA1069; TEA1069A

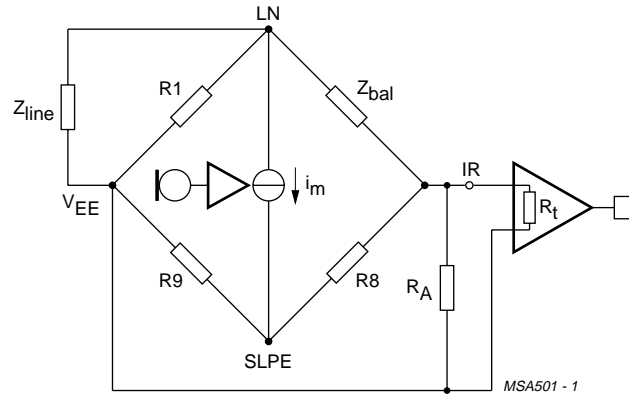

Fig.11 Equivalent circuit of an anti-sidetone network in a Wheatstone bridge configuration.

Dialler and ringer part

SUPPLY VOLTAGE: PINS V_{DD} AND V_{EE}

The power supply must be maintained for data storage. The RAM retention voltage (standby supply voltage) may drop down to 1.0 V. Applying a large capacitor across the supply terminals can retain the memory if power connections are broken. The minimum operation voltage is 2.5 V. The internal power-on reset is enabled for a voltage below this minimum operation voltage.

OSCILLATOR INPUT/OUTPUT: PINS XTAL1 AND XTAL2

Time base for the TEA1069 and TEA1069A is a crystal-controlled on-chip oscillator which is completed by connecting a 3.579545 MHz crystal or ceramic resonator between XTAL1 and XTAL2. The oscillator starts when V_{DD} reaches the operation voltage level and CE/FDI = HIGH. The following types of ceramic resonators are recommended:

- Kyocera PBRC3.58ARPC10 (wired)
- Kyocera KBR3.58MSATRPC10 (SMD)
- Murata CSA3.58MG310VA (wired).

RESET INPUT: PIN RESET

Pin RESET is an input to the internal reset circuit. When RESET = HIGH, it can be used to initialize the TEA1069 and TEA1069A which is normally done by the CE/FDI input. The on-chip power-on reset generates a reset pulse if V_{DD} drops below 2.5 V. In this event a proper start-up

occurs after the supply voltage rises above the minimum operation voltage level again.

During and directly after reset pins 14 to 19, 21, 29 to 32, 34 and 35 are set HIGH; pins 8, 20, 22, 26 to 28 and 33 are set to LOW.

The RESET pin can be connected to V_{EE} , preferably via a resistor of 100 k Ω to 1 M Ω , which will save leakage current. A capacitor connected to V_{DD} can be used to extend the reset time, in case a longer reset is desirable.

To prevent the dialler from reacting on voltage disturbances on the telephone line a time-out is active. The dialler returns to standby state if the voltage on the line has disappeared for more than this reset-delay time (t_{rd}).

CHIP ENABLE/FREQUENCY DISCRIMINATOR INPUT: PIN CE/FDI

This active HIGH input is used to initialize part of the system, to select the on-line, standby, or ringer mode and to detect line power breaks. To keep the TEA1069 and TEA1069A in the on-line mode, CE/FDI has to be HIGH.

In the exchange, several AC signals can be superimposed on the DC signal, e.g. dialling tone, busy tone, disturbances (like line power breaks), and the ringer signal. The ringer signal is evaluated, and checked if its frequency is within the limits of the frequency interval as set by the diode option RFS. It is assumed that the ringer frequency at pin CE/FDI is the double of the frequency present on the telephone line.

Versatile speech/dialler/ringer with music-on-hold

TEA1069; TEA1069A

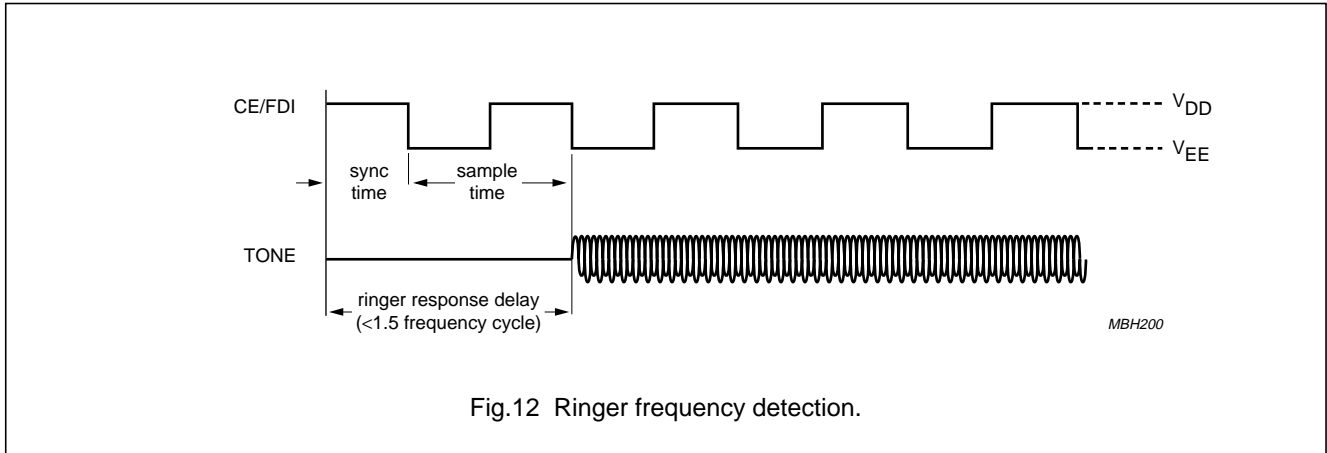

Fig.12 Ringer frequency detection.

In case of a valid ringer signal the user is alerted through a melody at the TONE output, generated by the ringer part of the TEA1069 and TEA1069A. This melody follows the cadence of the ringer signal. Both the melody and the volume can be selected. The melody frequency and duration are given in Table 2.

Table 2 Ringer melodies

NAME	FREQUENCY (Hz)	DURATION (ms)
Bell 1	800 + 1066 + 1333	28 + 28 + 28
Bell 2	826 + 925 + 1027	28 + 28 + 28
Bell 3	1037 + 1161 + 1297	28 + 28 + 28
Bell 4	1297 + 1455 + 1621	28 + 28 + 28

CRADLE SWITCH INPUT: PIN CSI

To distinguish among different operating states after CE/FDI is activated, input CSI is used. The basic states are shown in Table 3.

Table 3 TEA1069 and TEA1069A basic states

INPUT CSI	INPUT CE/FDI	STATE
LOW	LOW	standby
HIGH	LOW	not applicable
LOW	HIGH	ringer
HIGH	HIGH	on-line

For the hands-free state refer to Fig.23.

PULSE DIALLER: PINS DP/FL, MOH/DMO AND $\overline{\text{MUTE}}$

The pulse dialling system uses line current interruptions to signal the digits dialled to the exchange. The number of line current interruptions corresponds with the digit dialled except for the digit [0] which is characterized by 10 interruptions. Before each digit there is an inter-digit pause.

Valid keys are the digits [0] to [9] and [PAUSE].

The pulse dialling mode, the make/break ratio and the access pause time depend on the diode options: PTS, M/B, APT and APT2. DP/FL is LOW when V_{DD} is below power-on reset trip level and when RESET is HIGH.

The MOH/DMO pin (diode GOS = on) is used to reduce the voltage swing over the a/b terminals during pulse dialling. Several countries require this feature. The $\overline{\text{MUTE}}$ pin is an open drain output which requires a pull-up resistor. $\overline{\text{MUTE}}$ is HIGH when V_{DD} is below power-on reset trip level and when RESET is HIGH.

Figure 13 shows the timing diagram in pulse dialling mode when keys [3], [RECALL] and [4] are pressed.

Versatile speech/dialler/ringer with music-on-hold

TEA1069; TEA1069A

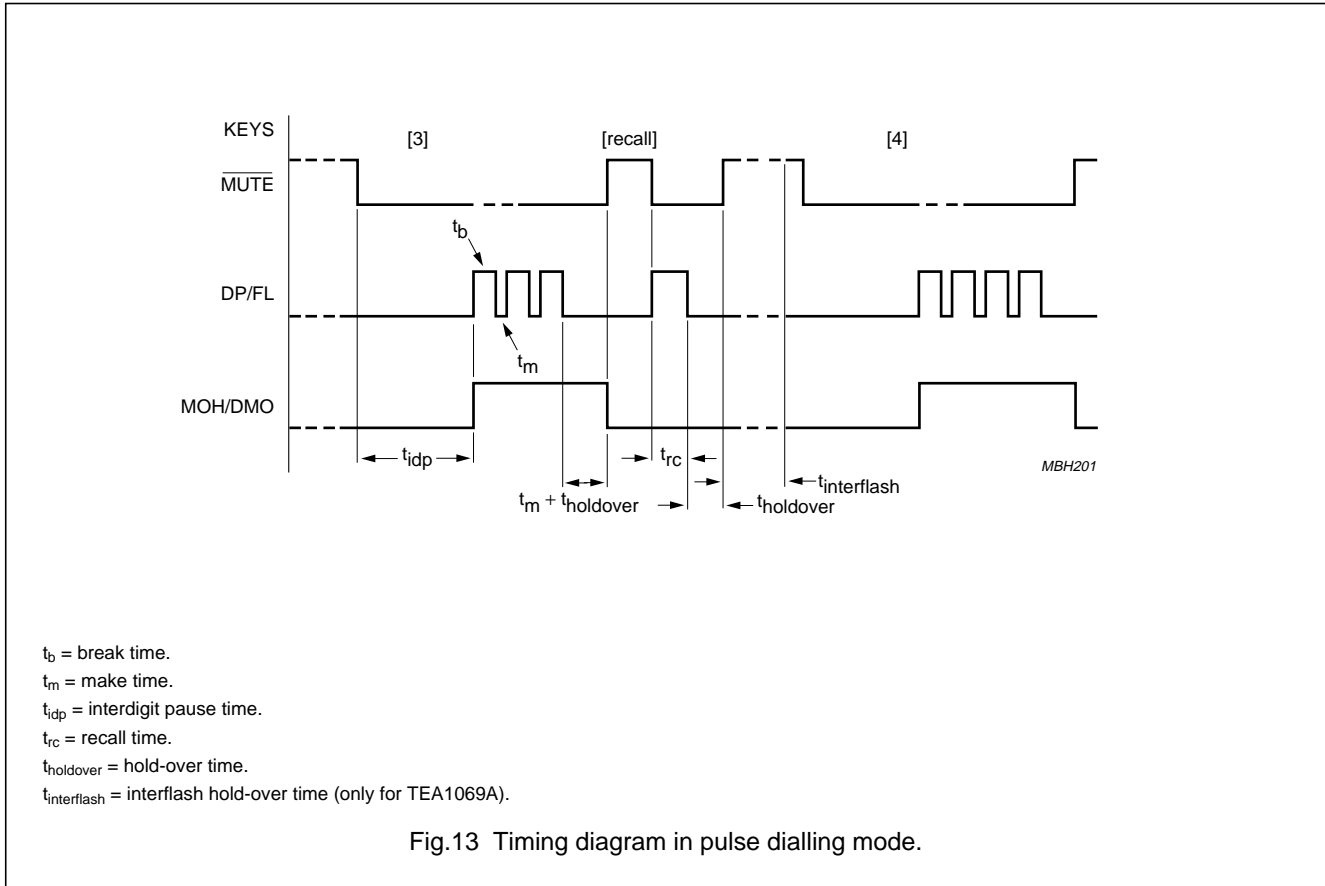

TONE DIALLER: PINS TONE AND \overline{MUTE}

In this system digits are transmitted as two tones simultaneously, the so called Dual-Tone Multi-Frequency (DTMF) system. Tone digits are separated by a pause time. Valid keys are the digits [0] to [9], [*], [#] and [PAUSE].

The DTMF dialling mode, the tone burst/pause times and the access pause time depend on the diode options: PTS, TBT, APT and APT2.

The \overline{MUTE} pin is an open drain output which requires a pull-up resistor. \overline{MUTE} is HIGH when V_{DD} is below power-on reset trip level and when RESET is HIGH.

Figure 14 shows the timing diagram in tone dialling mode when successively keys [3], [3], [RECALL] and [4] are dialled.

Versatile speech/dialler/ringer with music-on-hold

TEA1069; TEA1069A

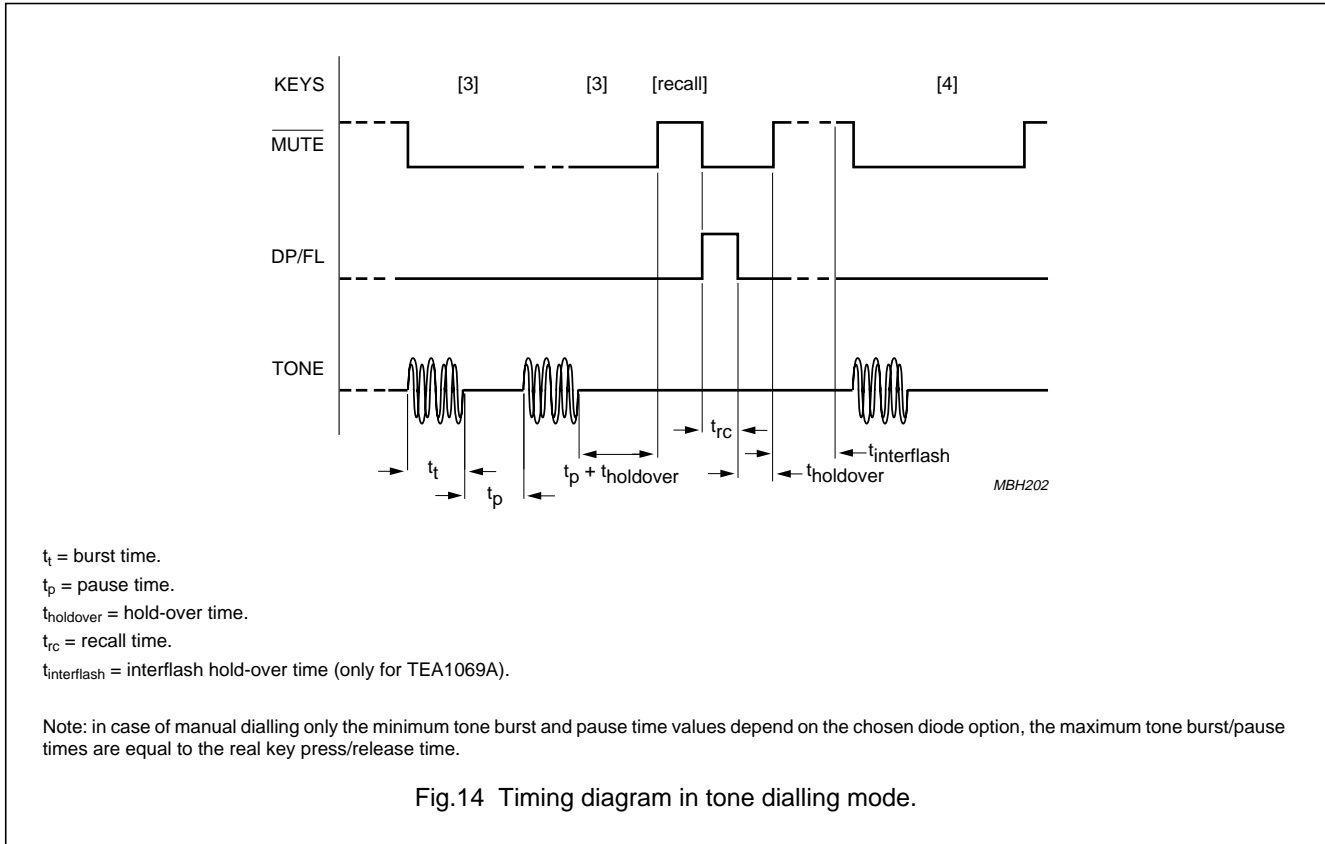

The DC-level at the TONE output measures $\frac{1}{2}V_{DD}$ and the impedance is typically 100 Ω . DTMF frequencies are composed by transmitting 2 tones simultaneously at pin TONE. The frequency tolerance for the tones at output TONE is shown in Table 4.

Table 4 DTMF frequency tolerances

DTMF FREQUENCY	FREQUENCY AT TONE	DEVIATION (%)	DEVIATION (Hz)
697	697.90	+0.13	+0.90
770	770.46	+0.06	+0.46
852	850.45	-0.18	-1.55
941	943.23	+0.24	+2.23
1209	1206.45	-0.21	-2.55
1336	1341.66	+0.42	+5.66
1477	1482.21	+0.35	+5.21

Versatile speech/dialler/ringer with music-on-hold

TEA1069; TEA1069A

REGISTER RECALL: PINS DP/FL AND KT/EARTH

The RECALL function results in a calibrated pulse which drives the electronic line current interrupter via pin DP/FL or KT/EARTH. Flash or earth selection and various flash interruption times depend on the diode options: FES A and FES B (diode GOS = **on**; see Fig.15).

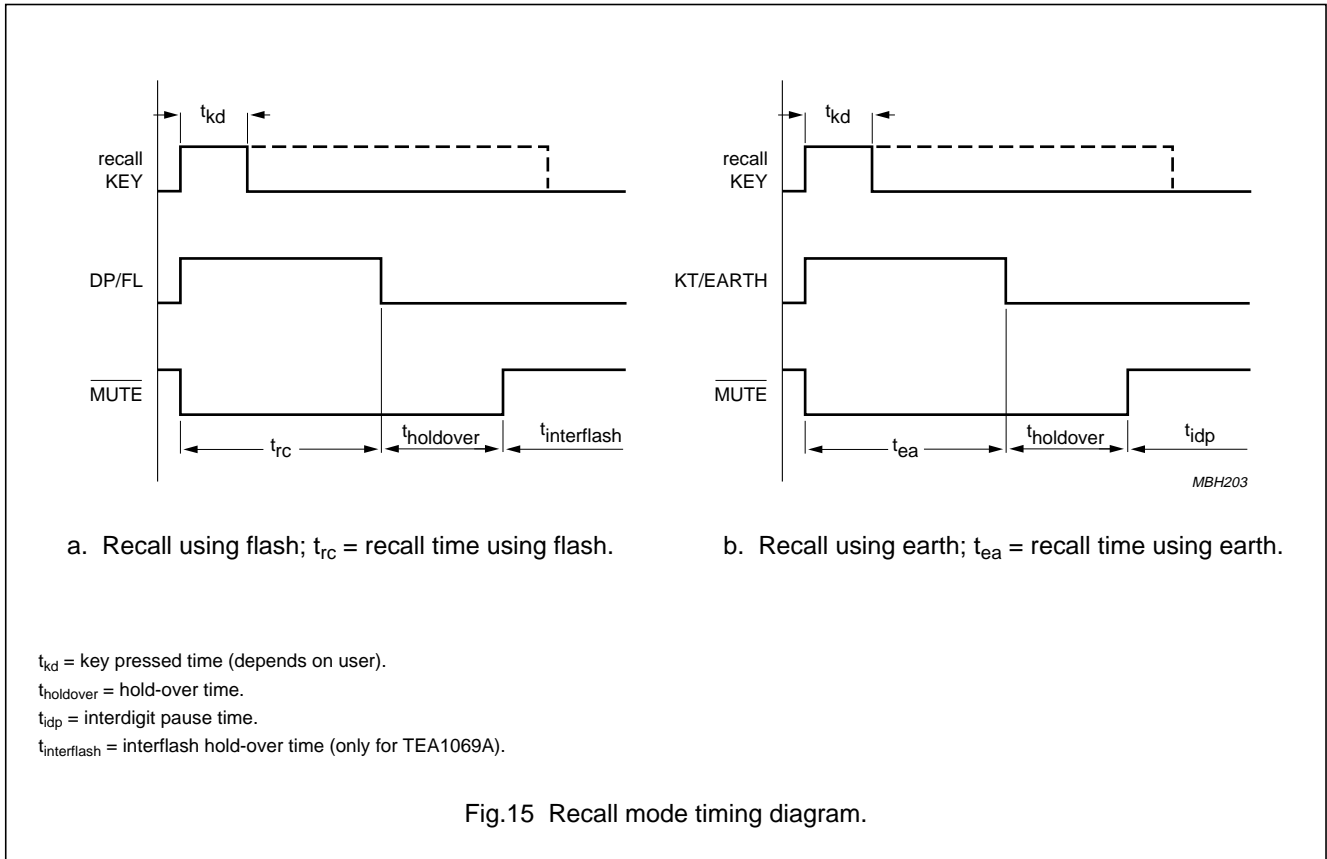

KEYBOARD: PINS ROW1 TO ROW5 AND COL1 TO COL6

The sense columns inputs and scanning rows outputs are directly connected to a single contact keyboard matrix. A second key entry will be valid after having released the first button and after having pressed the second button. Simultaneously pressing 2 buttons will disable the first entered key. A key entry becomes valid when the debounce time t_d has elapsed.

The column and row pins (except ROW5) are HIGH when V_{DD} is below power-on reset trip level and when RESET is HIGH.

ROW5 is an open-drain input/output; this configuration is used to avoid current flowing in the on-line or standby state. A pull-up resistor should be connected to ROW5. ROW5 is LOW when V_{DD} is below power-on reset trip level and when RESET is HIGH.

Versatile speech/dialler/ringer with music-on-hold

TEA1069; TEA1069A

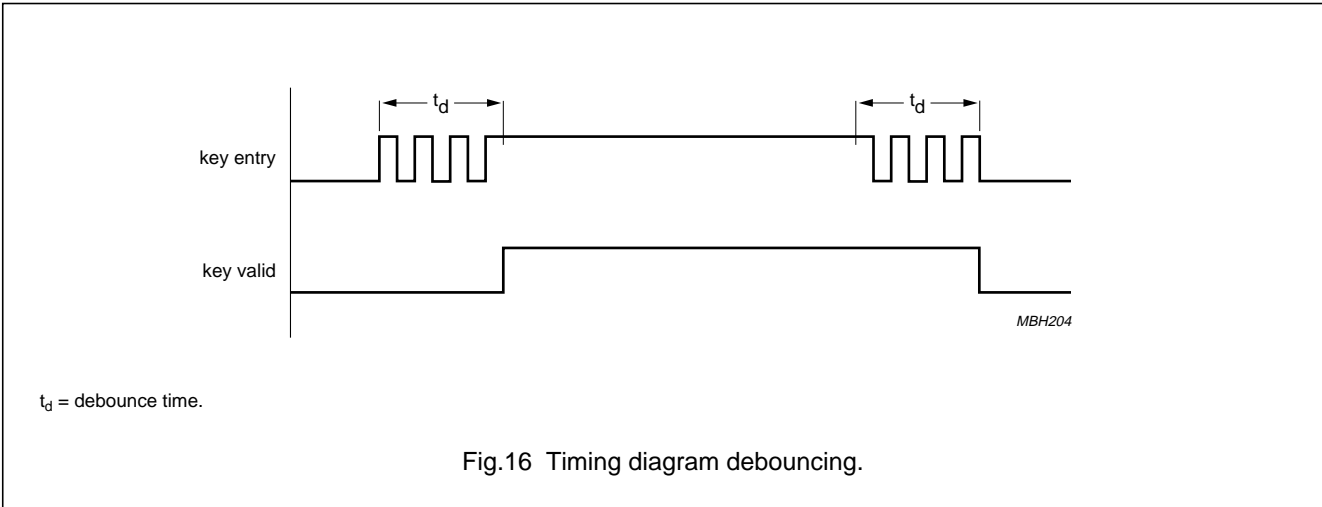

Keyboard layout

The TEA1069 and TEA1069A support three different keyboard layouts:

- With 10 direct accessible repertory numbers
- With 10 indirect accessible repertory numbers
- With 3 direct accessible repertory numbers and 10 indirect numbers.

For layouts see Figs 17 to 19; the keyboard layout can be selected by diode option KBS.

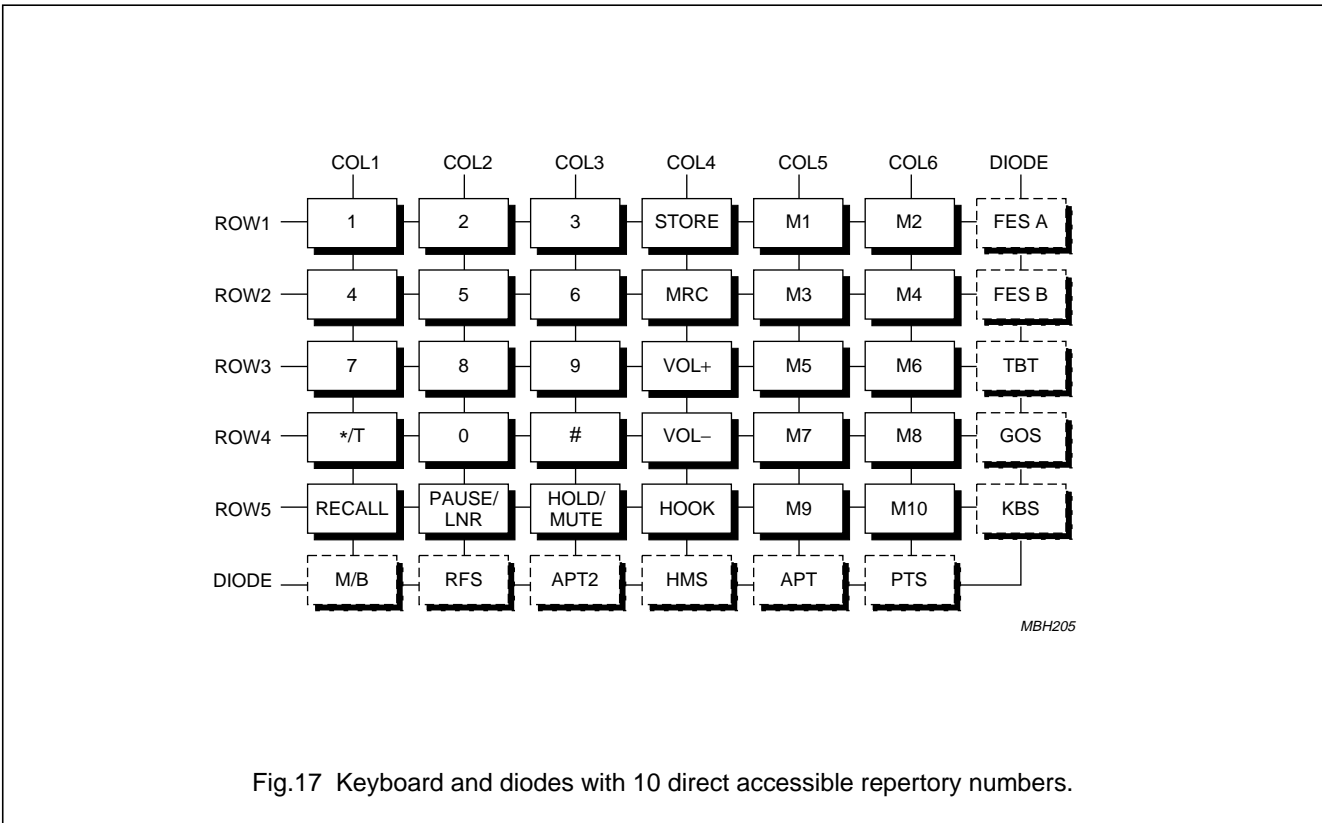

Versatile speech/dialler/ringer with music-on-hold

TEA1069; TEA1069A

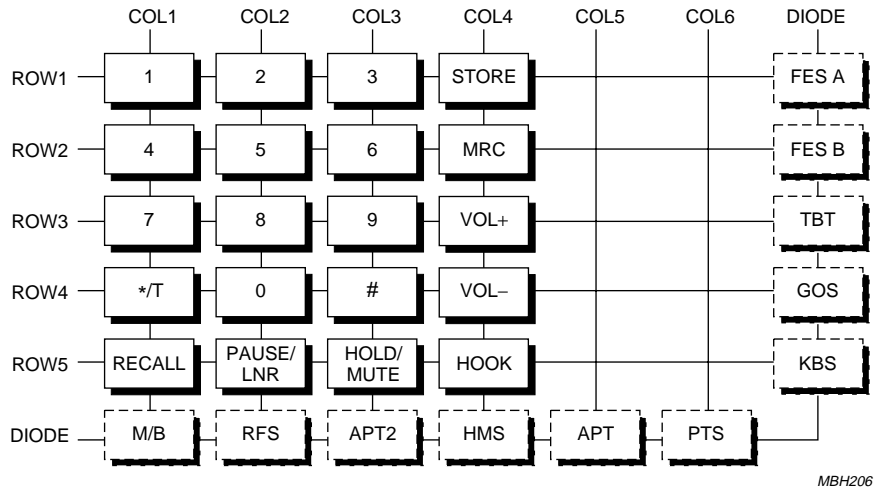

Fig.18 Keyboard and diodes with 10 indirect accessible repertory numbers.

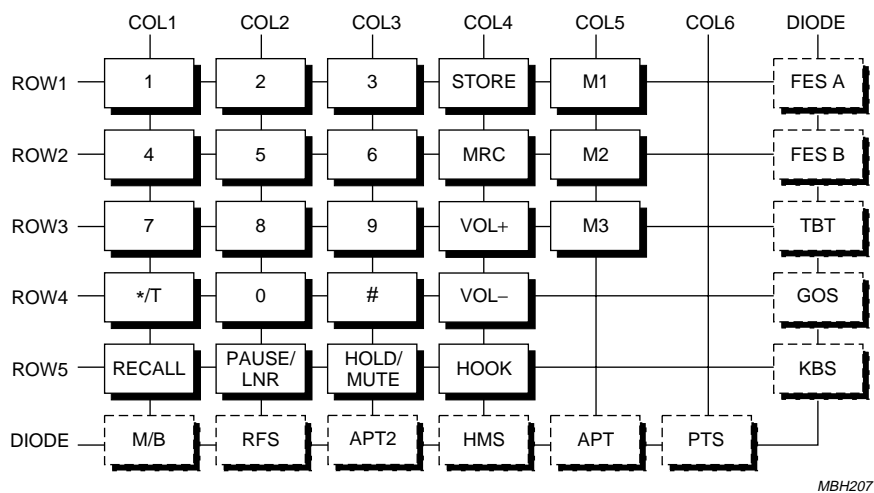

Fig.19 Keyboard and diodes with 3 direct and 10 indirect accessible repertory numbers.

Versatile speech/dialler/ringer with music-on-hold

TEA1069; TEA1069A

DIODE OPTIONS: PIN DIODE

The DIODE pin is connected to the keyboard matrix as shown in Fig.20.

The diode options are read after each reset of the dialler.

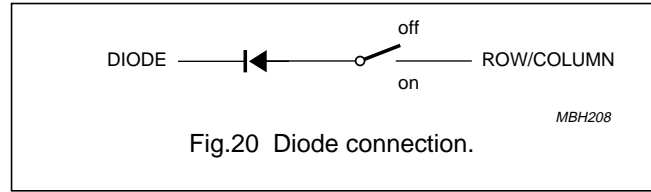

Table 5 DIODE functions; TEA1069

DIODE	FUNCTION	CONDITION	ON ⁽¹⁾	OFF ⁽¹⁾
FES A	flash/earth time select	FES B = off	flash of 270 ms	flash of 100 ms
		FES B = on	earth of 400 ms	flash of 600 ms
TBT	tone burst/pause time		85/85 ms	100/100 ms
GOS	german output select		pin 8 = earth; pin 27 = DMO	pin 8 = keytone; pin 27 = MOH
KBS	keyboard select		keyboard layout; see Figs 17 and 18	keyboard layout; see Fig.19
PTS	pulse/tone selection		pulse mode	DTMF mode
APT	access pause time	APT2 = off	4 s	2 s
HMS	hold/mute select		hold mode	mute mode
RFS	ringer frequency select		29 to 146 Hz	40 to 120 Hz
M/B	make/break ratio		3 : 2	2 : 1

Note

- 1. **on** means option diode present; **off** means option diode not present.

Table 6 DIODE functions; TEA1069A

DIODE	FUNCTION	CONDITION	ON ⁽¹⁾	OFF ⁽¹⁾
FES A	flash/earth time select	FES B = off	flash of 270 ms	flash of 100 ms
		FES B = on	earth of 400 ms	flash of 600 ms
TBT	tone burst/pause time		85/85 ms	100/100 ms
GOS	german output select		pin 8 = earth; pin 27 = DMO	pin 8 = keytone; pin 27 = MOH
KBS	keyboard select		keyboard layout; see Fig.19	keyboard layout; see Figs 17 and 18
PTS	pulse/tone selection		pulse mode	DTMF mode
APT	access pause time	APT2 = off	4 s	1 s
		APT2 = on	3 s	2 s
HMS	hold/mute select		hold mode	mute mode
RFS	ringer frequency select		40 to 120 Hz	29 to 146 Hz
M/B	make/break ratio		3 : 2	2 : 1

Note

- 1. **on** means option diode present; **off** means option diode not present.

Versatile speech/dialler/ringer with music-on-hold

TEA1069; TEA1069A

KEY TONE: PIN KT/EARTH

Every time a valid key is pressed a keytone is generated with a frequency of 606 Hz and a duration of 30 ms. This function is selected by the diode GOS = **off**. KT/EARTH is LOW when V_{DD} is below power-on reset trip level and when RESET is HIGH.

VOLUME CONTROL: PINS VOL1 AND VOL2

Both pins can control the volume of the ringer and/or the hands-free circuit. The state of VOL1/VOL2 is controlled by a state machine as depicted in Fig.24.

VOL1 and VOL2 are push-pull outputs. Both are set LOW when V_{DD} is below power-on reset trip level and when RESET is HIGH.

MUSIC-ON-HOLD: PIN MOH/DMO

When the dialler is in the hold state (see Fig.23) a melody is generated via pin TONE. In this state pin MOH/DMO can be used via diode GOS = **off** as an enable signal for the hardware to indicate that the tone should be switched to the telephone line.

MOH/DMO is a push-pull output. It is set LOW when V_{DD} is below power-on reset trip level and when RESET is HIGH.

HANDS-FREE: PIN HF

During the on-line state, the hands-free output pin HF is used for enabling the hands-free hardware. The pin will change state depending on specific key-sequences (see Fig.23).

HF is a push-pull output. It is set LOW when V_{DD} is below power-on reset trip level and when RESET is HIGH.

HOLD MODE: PIN HOLD

One way to terminate the hold state (see Fig.23) is a change in state of the signal at pin HOLD. This input should reflect the line current. If current is flowing the signal at pin HOLD should be HIGH, if not it should be LOW.

This pin is not debounced. The signal applied should be filtered by the hardware. HOLD is HIGH when V_{DD} is below power-on reset trip level and when RESET is HIGH.

Key sequences

The behaviour of the TEA1069 and TEA1069A can be modelled as a State Transition Diagram (STD) shown in Fig.21.

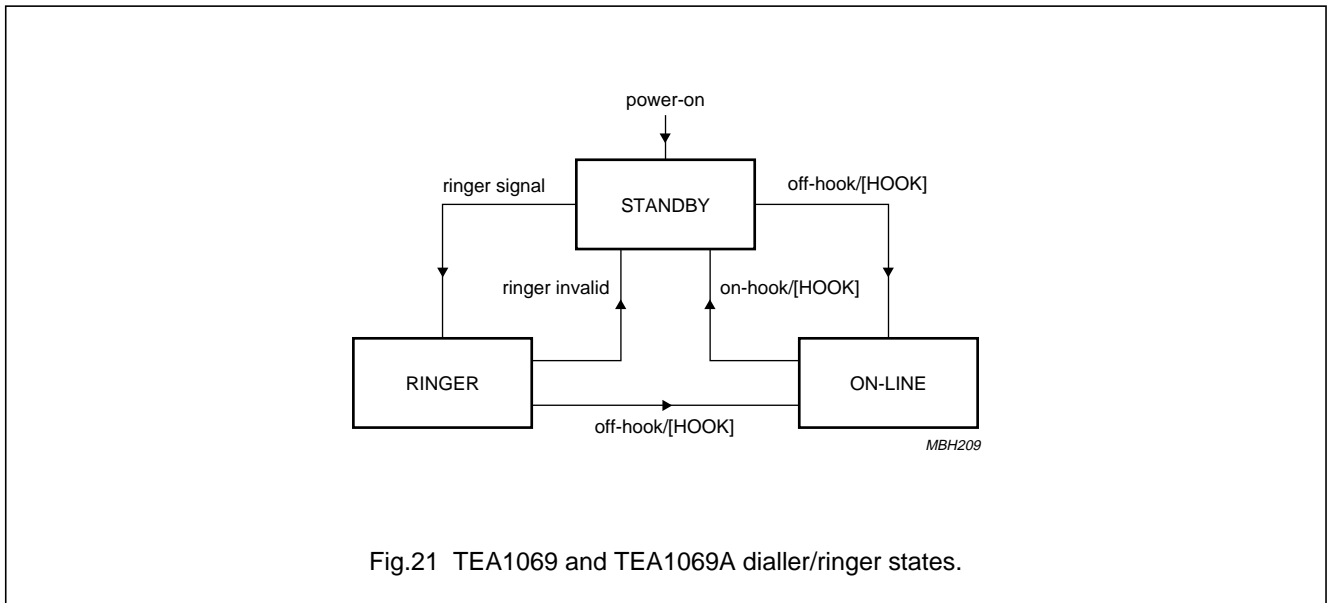

Fig.21 TEA1069 and TEA1069A dialler/ringer states.

Versatile speech/dialler/ringer with music-on-hold

TEA1069; TEA1069A

The STD contains the states (rectangles in the figure) and state transitions (arrows) of the set. The upper arrow in the figure pointing to the standby state means that the set is initially in the standby state. When for instance an incoming call is detected, the set enters the ringer state, waiting for a reaction of the user. If the user answers the call on a handset, the set enters the on-line state.

The TEA1069 and TEA1069A have 3 basic states:

- Standby state
- Ringer state
- On-line state.

Each state with its own functional requirements is described in the following sections.

STANDBY STATE

In standby state the TEA1069 and TEA1069A are inactive. The current drawn is for memory retention and depends on the loads of the inputs/outputs of the dialler. In this state output DP/FL is HIGH so that the line is disconnected.

The ICs leave the standby state if:

- The set goes off-hook (lift handset or press [HOOK])
- A ringer-signal is available on the line.

The ICs go to the standby state if:

- The set goes on-hook (handset on the cradle or press [HOOK])
- A line-break occurs for at least the reset delay time (t_{rd})
- The ringer-signal becomes invalid.

RINGER STATE

If the set is in standby mode, a ringer signal can be received from the line. After evaluating the incoming ringer signal (and ringer signal is valid), the TEA1069 and TEA1069A start a melody via the TONE output ringer hardware, and stops this melody if the ringer signal is not valid any more. After going off-hook, the ringer signal stops and the set is in conversation (on-line) state.

During a ringer burst the ringer volume can be changed according to Fig.24 and melodies can be changed according to Table 7.

Table 7 Melody selection

MELODY	KEY
Bell 1	[1]
Bell 2	[2]
Bell 3	[3]
Bell 4	[4]

ON-LINE STATE

In this paragraph all the actions of the TEA1069 and TEA1069A during on-line state are described. The on-line mode starts with making output DP/FL LOW, which makes line current flow possible. The on-line state contains a number of sub-states (see Fig.22):

- Conversation state
- Dialling state
- Memory recall state
- Program state.

Versatile speech/dialler/ringer with music-on-hold

TEA1069; TEA1069A

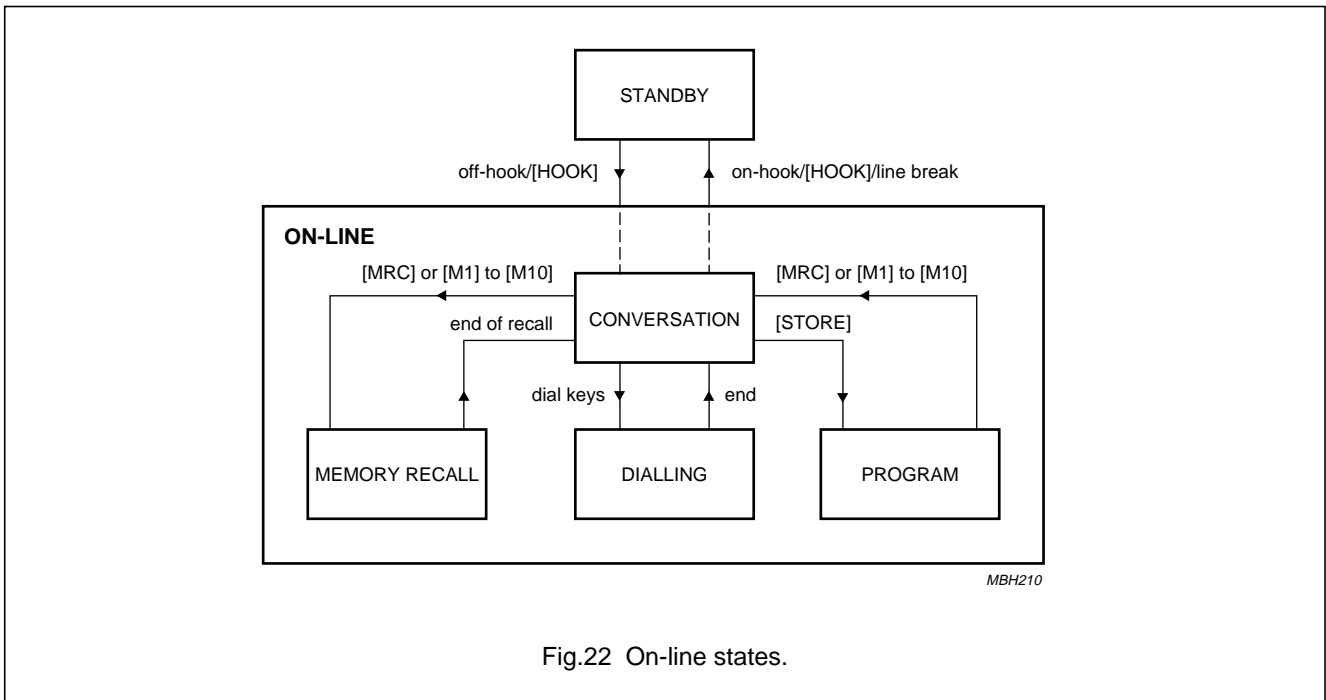

Fig.22 On-line states.

Conversation state

In this state conversation is possible. A number of sub-states (see Fig.23) exist:

- Handset state
- Hands-free state
- Hold state
- Mute state.

Depending on the diode option HMS the hold or the mute state is selected.

Versatile speech/dialler/ringer with music-on-hold

TEA1069; TEA1069A

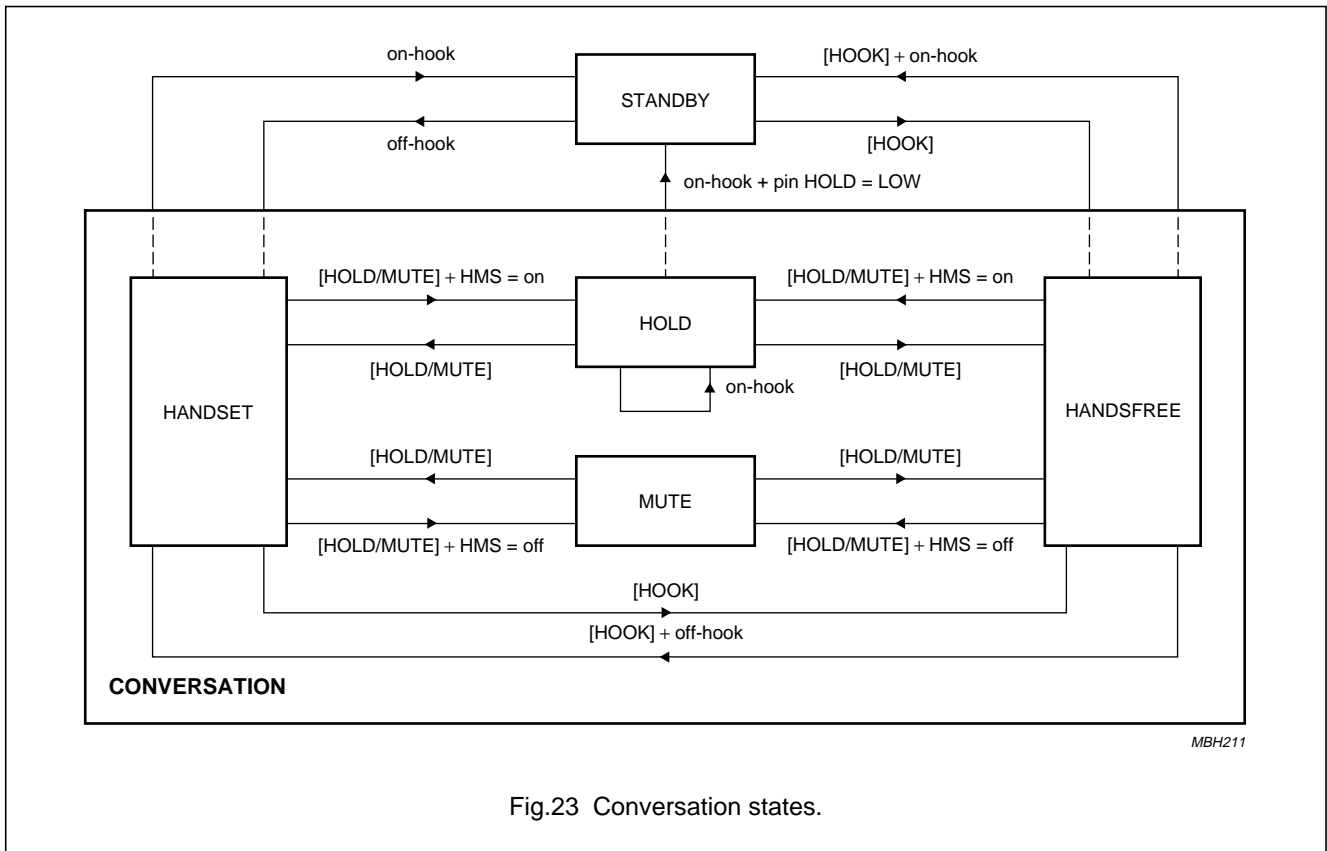

Fig.23 Conversation states.

- Handset state.
The conversation states are shown in Fig.23.
- Hands-free state.
In hands-free mode output HF becomes HIGH which activates a TEA1093/1094 hands-free IC. This state can be reached from standby state and from the handset state as follows:
 - the [HOOK] key is pressed during standby mode
 - the [HOOK] key is pressed during handset state is lifted, then when the handset is put on the cradle the set stays in the hands-free mode.
 The set leaves the hands-free mode and output HF becomes LOW when:
 - the [HOOK] key is pressed and the handset is on the cradle, the set goes to the standby mode
 - the [HOOK] key is pressed and the handset is lifted, the set goes to the handset state.
 The volume on the loudspeaker or buzzer, in hands-free and ringer mode, can be controlled in four levels using the [VOL+] and [VOL-] keys.

- Hold state.
The hold state is entered when the [HOLD/MUTE] key is pressed (diode HMS = **on**). This state can be entered either from handset state or from hands-free state. Upon entering this state outputs HF and MUTE become LOW. In hold state a music-on-hold melody is generated by output TONE. Pin MOH/DMO is HIGH (diode GOS = **off**) during this state. This signal can be used to adjust the volume of the TONE pin. Since MUTE is LOW the TONE output is transmitted to the telephone line. As long as the TEA1069 and TEA1069A are in this state the HOLD input pin is tested. The set leaves the hold state when:
 - [HOLD/MUTE] is pressed, the set returns to either the handset or hands-free state
 - the HOLD input becomes LOW, now the TEA1069 and TEA1069A return to the standby state.
 The hands-free volume can be changed according to Fig.24.

Versatile speech/dialler/ringer with music-on-hold

TEA1069; TEA1069A

• Mute state.

When the [HOLD/MUTE] key is pressed (HMS = **off**) the mute state is entered and MUTE becomes LOW.

In mute state a music-on-hold melody is generated by output TONE. Pin MOH/DMO is HIGH (diode GOS = **off**) during this state.

This signal can be used to adjust the volume of the TONE pin. Since MUTE is LOW the TONE output is transmitted to the telephone line. The mute state is left when:

- [HOLD/MUTE] is pressed, set returns to either handset- or hands-free state
- a dial action is started.

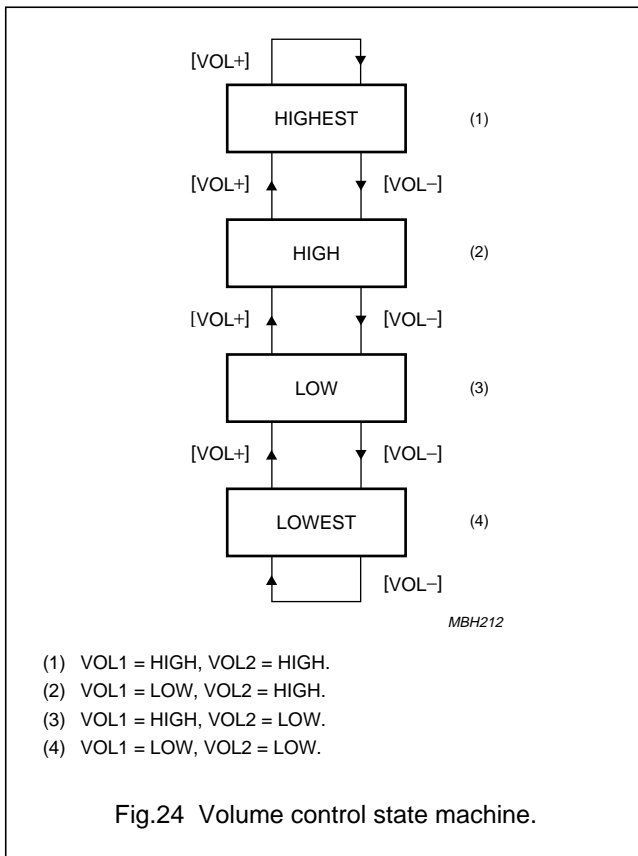

Dialling state

During the dial-keys entries the TEA1069 and TEA1069A start immediately with transmission of the digit(s); the minimum transmission time is unaffected by the speed of the entry. Transmission continues as long as further dial-keys entries have to be processed.

However when keying-in is much faster than dialling-out, then the 32 digit dialling register will overflow. When this occurs the dialling is stopped and the error beep will be generated.

There are two dial modes: pulse dialling and tone dialling. The initial dialling mode is determined by option PTS.

The state machine which controls the dial mode is shown in Fig.25.

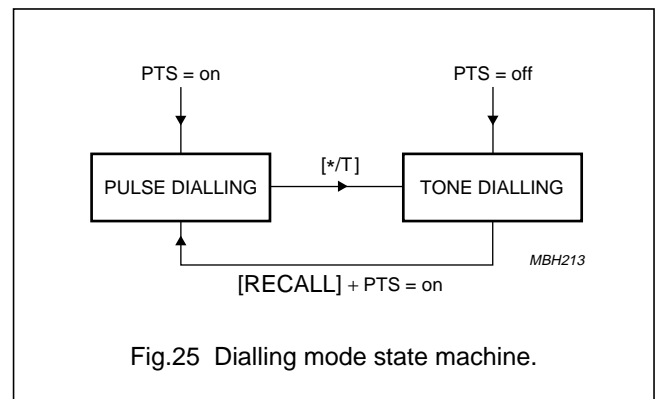

• Pulse dialling.

In this mode all valid keys are dialled by the pulse dialler. When during pulse dialling key [* / T] is pressed, the TEA1069 and TEA1069A switch over to tone dialling (mixed mode dialling). After the switch-over, valid keys are dialled by the tone dialler. The temporary tone mode is terminated by going on-hook or recall.

• Tone dialling.

The ICs convert valid keys into data for the on-chip DTMF generator. Tones are transmitted via output TONE with minimum tone burst/pause duration. The maximum tone burst/pause duration is equal to the key pressing/release time.

• Register recall (flash/earth).

The [RECALL] key will result in a flash or earth action.

• Access pause.

When the [PAUSE/LNR] button is not the first key pressed, an access pause is entered for repertory or redialling procedures. When an access pause is executed MUTE is HIGH. During manual dialling no access pauses are dialled.

• Last Number Redial (LNR).

If the first key pressed is the [PAUSE/LNR] button, the number stored in the redial register is recalled and transmitted. A maximum number of 32 digits can be

Versatile speech/dialler/ringer with music-on-hold

TEA1069; TEA1069A

accepted for last number redial. If this maximum is reached the redial function is inhibited. During LNR programmed access pauses are also dialled.

The [RECALL] key and the (in pulse dialling mode allowed) tone switch key [*/T] are also stored in LNR memory.

- Notepad function.

In conversation state it is possible to store a number into the LNR register, which may be dialled after an on-hook/off-hook action. The procedure is as follows:

- press [STORE]
- press to-be-stored sequence of the digits [0] to [9], [PAUSE/LNR], [*/T] or [RECALL]
- press [STORE]
- press [PAUSE/LNR].

Memory recall state

Repertory numbers can be dialled-out after or before entering manual dialling, last number redial and by entering the memory locations in successive order.

The stored numbers can be dialled by the following procedures:

- Press [MRC]
- Press one of the numeric keys [0] to [9], corresponding to the memory location

or

- Press one of the direct memory keys ([M1] to [M10]).

Program state

The program mode can be entered from the conversation (on-line) mode.

Pressing the [STORE] key in this state puts the TEA1069 and TEA1069A in the program mode. The program state can be left by going on-hook (by putting the handset on the cradle or pressing the [HOOK] key), the program mode is interrupted and nothing is stored, or by ending the store procedures resulting in a proper store of the programmed item.

- Programming repertory numbers.

Storing of a new repertory number including access pauses, tone switch and register recall can be done by the following procedures:

- press [STORE]
- press to-be-stored sequence of the digits [0] to [9], [PAUSE/LNR], [*/T] or [RECALL]
- press [MRC]

- press one of the numeric keys [0] to [9], corresponding to the memory location

or

- press [STORE]
- press to-be-stored sequence of the digits [0] to [9], [PAUSE/LNR], [*/T] or [RECALL]
- press [M1] to [M10].

For storing the redial number in repertory use:

- press [STORE]
- press [PAUSE/LNR]
- press [MRC]
- press one of the numeric keys [0] to [9], corresponding to the memory location

or

- press [STORE]
- press [PAUSE/LNR]
- press [M1] to [M10].

If the keyboard described in Fig.17 is selected by the KBS diode option, repertory memory place [M1] = [MRC] + [1] to [M10] = [MRC] + [0], thus the set has 10 repertory numbers which can be selected via two different ways.

If the keyboard described in Fig.19 is selected by the KBS diode option repertory memory place [MRC] + [0] to [MRC] + [9] and [M1], [M2] and [M3] are different repertory numbers, thus this set has in total 13 repertory numbers.

- Memory overflow.

A maximum of 224 digits can be stored in the repertory memories. When the maximum is reached, no keytone is generated when trying to store more digits. The store procedure is cancelled automatically.

- Clear repertory number.

Clearing a memory location is possible via the same procedure as for storing a number, except no telephone number is entered, thus one of the following sequences must be used:

- press [STORE]
- press [MRC]
- press one of the numeric keys [0] to [9], corresponding to the memory location

or

- press [STORE]
- press [M1] to [M10].

Versatile speech/dialler/ringer with music-on-hold

TEA1069; TEA1069A

LIMITING VALUES

In accordance with the Absolute Maximum Rating System (IEC 134).

SYMBOL	PARAMETER	CONDITIONS	MIN.	MAX.	UNIT
I_{line}	line current	$R_9 = 20 \Omega$; note 1	–	140	mA
I_{EE}	ground supply current through V_{EE}		–	50	mA
P_{tot}	total power dissipation	$R_9 = 20 \Omega$; note 2			
	TEA1069N		–	770	mW
	TEA1069H and TEA1069AH		–	300	mW
T_{amb}	operating ambient temperature		–25	+70	°C
T_{stg}	IC storage temperature		–40	+125	°C
Speech part					
V_{LN}	positive continuous line voltage		–	12	V
$V_{LN(R)}$	repetitive line voltage during switch-on or line interruption		–	13.2	V
V_{CC}	input voltage on pin V_{CC}		–	12	V
V_i	input voltage on pins 1 to 7, 37, 38, 39, 41, 42		$V_{EE} - 0.7$	$V_{CC} + 0.7$	V
Dialler/ringer part					
V_{DD}	supply voltage		–0.7	+7	V
V_i	input voltages on pins 8 to 22, 24, 26 to 35		$V_{EE} - 0.7$	$V_{DD} + 0.7$	V
I_i	DC input current on pins 8 to 22, 24, 26 to 35		–10	+10	mA
I_o	DC output current on pins 8 to 22, 24, 26 to 35		–10	+10	mA
P_o	power dissipation per output on pins 8 to 22, 24, 26 to 35		–	30	mW

Notes

- Mostly dependent on the maximum required T_{amb} and on the voltage between LN and SLPE (see Fig.26 for TEA1069N or Fig.27 for TEA1069H and TEA1069AH).
- Calculated for the maximum specified ambient temperature ($T_{amb} = 70 \text{ °C}$, see also Fig.26 for TEA1069N or Fig.27 for TEA1069H and TEA1069AH).

THERMAL CHARACTERISTICS

SYMBOL	PARAMETER	VALUE	UNIT
$R_{th\ j-a}$	thermal resistance from junction to ambient in free air mounted on glass epoxy board $28.5 \times 19.1 \times 1.5 \text{ mm}$		
	TEA1069N	63	K/W
	TEA1069H and TEA1069AH	116	K/W

Versatile speech/dialler/ringer with music-on-hold

TEA1069; TEA1069A

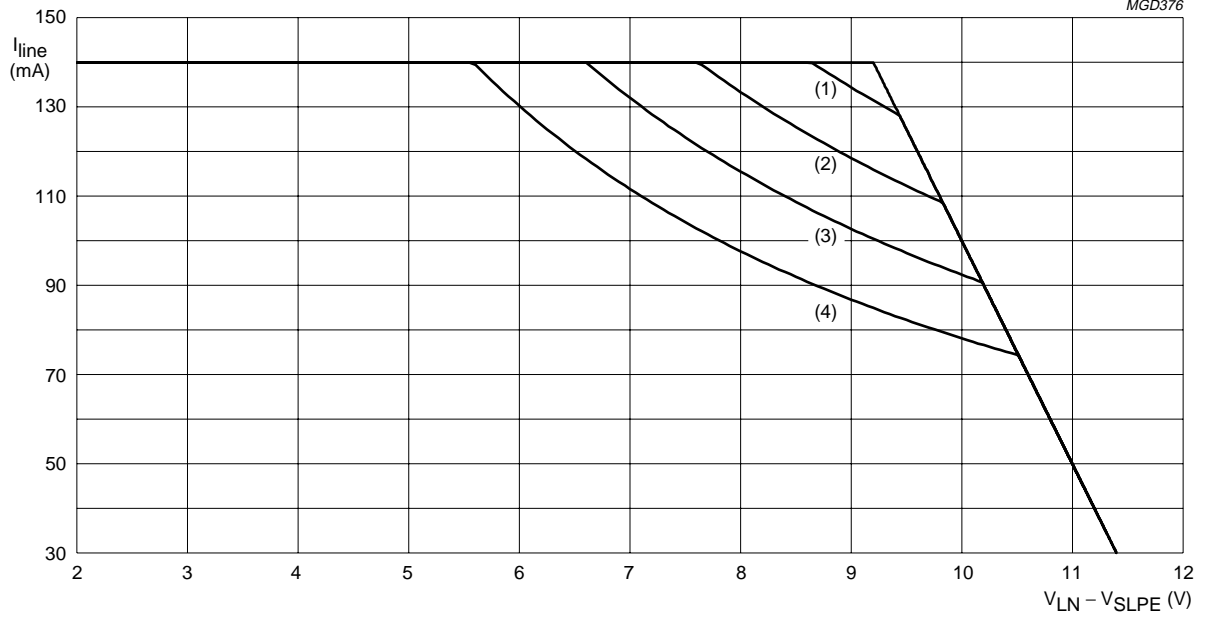

- (1) $T_{amb} = 40\text{ }^{\circ}\text{C}$; $P_{tot} = 1200\text{ mW}$.
- (2) $T_{amb} = 50\text{ }^{\circ}\text{C}$; $P_{tot} = 1050\text{ mW}$.
- (3) $T_{amb} = 60\text{ }^{\circ}\text{C}$; $P_{tot} = 910\text{ mW}$.
- (4) $T_{amb} = 70\text{ }^{\circ}\text{C}$; $P_{tot} = 770\text{ mW}$.

Note: calculations based upon negligible dialler and ringer parts output power (null port sink current).

Fig.26 TEA1069N safe operating area.

Versatile speech/dialler/ringer with music-on-hold

TEA1069; TEA1069A

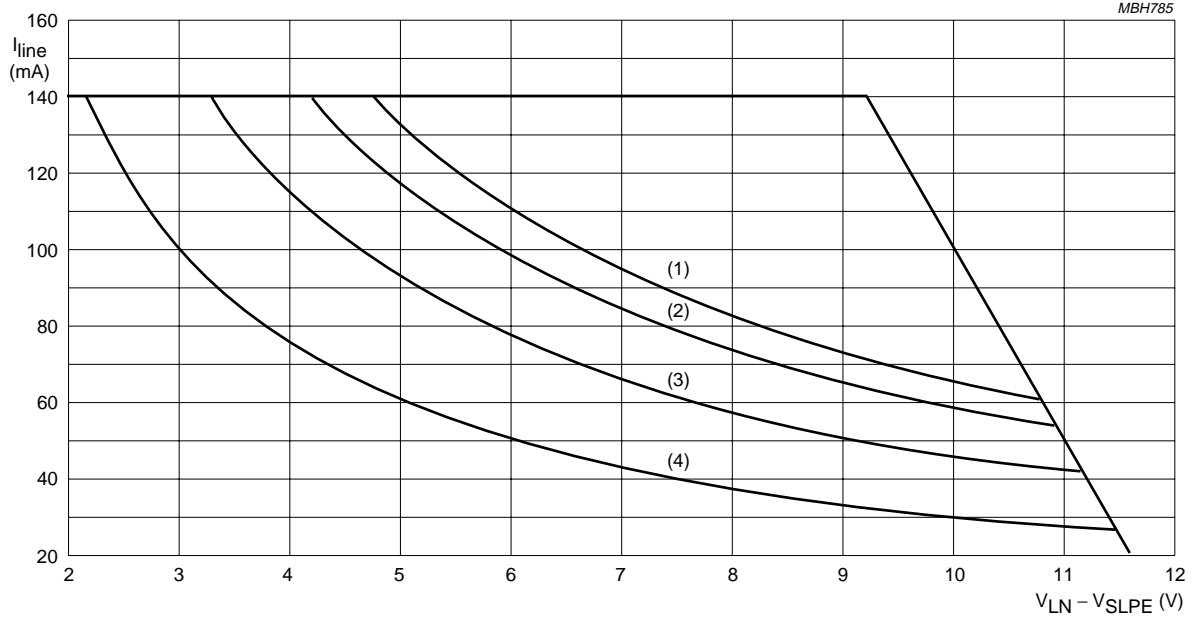

- (1) $T_{amb} = 40\text{ }^{\circ}\text{C}$; $P_{tot} = 665\text{ mW}$.
- (2) $T_{amb} = 50\text{ }^{\circ}\text{C}$; $P_{tot} = 590\text{ mW}$.
- (3) $T_{amb} = 60\text{ }^{\circ}\text{C}$; $P_{tot} = 460\text{ mW}$.
- (4) $T_{amb} = 70\text{ }^{\circ}\text{C}$; $P_{tot} = 300\text{ mW}$.

Note: calculations based upon negligible dialler and ringer parts output power (null port sink current).

Fig.27 TEA1069H and TEA1069AH safe operating area.

Versatile speech/dialler/ringer with music-on-hold

TEA1069; TEA1069A

CHARACTERISTICS
 $I_{line} = 11$ to 140 mA; $V_{EE} = 0$ V; $f = 1$ kHz; $V_{DD} = 3$ V; $f_{xtal} = 3.579545$ MHz; $T_{amb} = 25$ °C; unless otherwise specified.

SYMBOL	PARAMETER	CONDITIONS	MIN.	TYP.	MAX.	UNIT
Speech part						
SUPPLIES LN AND V_{CC} (PINS 40 AND 36)						
V_{LN}	voltage drop over circuit between LN and V_{EE}	MIC inputs open-circuit $I_{line} = 1$ mA $I_{line} = 4$ mA $I_{line} = 15$ mA $I_{line} = 100$ mA $I_{line} = 140$ mA	– – 3.55 4.9 –	1.6 1.9 4.0 5.7 –	– – 4.25 6.5 7.5	V V V V V
$\Delta V_{LN}/\Delta T$	variation with temperature	$I_{line} = 15$ mA	–	–0.3	–	mV/K
V_{LN}	voltage drop over circuit between LN and V_{EE} with external resistor R_{VA}	$I_{line} = 15$ mA R_{VA} (LN to REG) = 68 k Ω R_{VA} (REG to SLPE) = 39 k Ω	– –	3.5 4.5	– –	V V
I_{CC}	supply current	$V_{CC} = 2.8$ V	–	0.9	1.35	mA
V_{CC}	supply voltage available for peripheral circuitry	$I_{line} = 15$ mA; $\overline{MUTE} = LOW$ $I_p = 1.2$ mA $I_p = 0$ mA	2.2 –	2.7 3.4	– –	V V
MICROPHONE INPUTS MIC– AND MIC+ (PINS 3 AND 4)						
$ Z_i $	input impedance differential single-ended	between MIC– and MIC+ MIC– or MIC+ to V_{EE}	– –	64 32	– –	k Ω k Ω
CMRR	common mode rejection ratio		–	82	–	dB
G_v	voltage gain MIC+ or MIC– to LN	$I_{line} = 15$ mA; $R_7 = 68$ k Ω	50.5	52.0	53.5	dB
$\Delta G_{v(f)}$	gain variation with frequency referenced to 800 Hz	$f = 300$ and 3400 Hz	–	± 0.2	–	dB
$\Delta G_{v(T)}$	gain variation with temperature referenced to 25 °C	without R_6 ; $I_{line} = 50$ mA; $T_{amb} = -25$ to $+70$ °C	–	± 0.2	–	dB
DTMF INPUT (PIN 7)						
$ Z_i $	input impedance		–	20.7	–	k Ω
G_v	voltage gain from DTMF to LN	$I_{line} = 15$ mA; $R_7 = 68$ k Ω	24.0	25.5	27.0	dB
$\Delta G_{v(f)}$	gain variation with frequency referenced to 800 Hz	$f = 300$ and 3400 Hz	–	± 0.2	–	dB
$\Delta G_{v(T)}$	gain variation with temperature referenced to 25 °C	$I_{line} = 50$ mA; $T_{amb} = -25$ to $+70$ °C	–	± 0.2	–	dB
GAIN ADJUSTMENT INPUTS GAS1 AND GAS2 (PINS 41 AND 42)						
ΔG_v	transmitting amplifier gain variation by adjustment of R_7 between GAS1 and GAS2		–8	–	0	dB

Versatile speech/dialler/ringer with
music-on-hold

TEA1069; TEA1069A

SYMBOL	PARAMETER	CONDITIONS	MIN.	TYP.	MAX.	UNIT
SENDING AMPLIFIER OUTPUT LN (PIN 40)						
$V_{LN(rms)}$	output voltage (RMS value)	THD = 10%	–	0.8	–	V
		$I_{line} = 4 \text{ mA}$	1.7	2.3	–	V
$V_{no(rms)}$	noise output voltage (RMS value)	$I_{line} = 15 \text{ mA}$; $R7 = 68 \text{ k}\Omega$; 200 Ω between MIC– and MIC+; psophometrically weighted (P53 curve)	–	–69	–	dBmp
RECEIVING AMPLIFIER INPUT IR (PIN 6)						
$ Z_i $	input impedance		–	21	–	k Ω
RECEIVING AMPLIFIER OUTPUT QR (PIN 1)						
$ Z_o $	output impedance		–	4	–	Ω
G_v	voltage gain from IR to QR	$I_{line} = 15 \text{ mA}$; $R_L = 300 \text{ }\Omega$ (from pin 9 to pin 4)	29.5	31	32.5	dB
$\Delta G_{v(f)}$	gain variation with frequency referenced to 800 Hz	$f = 300$ and 3400 Hz	–	± 0.2	–	dB
$\Delta G_{v(T)}$	gain variation with temperature referenced to 25 °C	without R6; $I_{line} = 50 \text{ mA}$; $T_{amb} = -25$ and $+70 \text{ }^\circ\text{C}$	–	± 0.2	–	dB
$V_{o(rms)}$	output voltage (RMS value)	THD = 2%; sine wave drive; $R4 = 100 \text{ k}\Omega$; $I_{line} = 15 \text{ mA}$; $I_p = 0 \text{ mA}$	0.22	0.33	–	V
		$R_L = 150 \text{ }\Omega$	0.3	0.48	–	V
		$R_L = 450 \text{ }\Omega$	–	15	–	mV
$V_{no(rms)}$	noise output voltage (RMS value)	$I_{line} = 15 \text{ mA}$; $R4 = 100 \text{ k}\Omega$; IR open-circuit psophometrically weighted (P53 curve); $R_L = 300 \text{ }\Omega$	–	50	–	μV
GAIN ADJUSTMENT INPUT GAR (PIN 2)						
ΔG_v	receiving amplifier gain variation by adjustment of R4 between GAR and QR		–11	–	0	dB
MUTE (PIN 35) GAIN REDUCTION						
ΔG_v	MIC+ or MIC– to LN	$\overline{\text{MUTE}} = \text{LOW}$	–	70	–	dB
G_v	voltage gain from DTMF to QR	$R4 = 100 \text{ k}\Omega$; $R_L = 300 \text{ }\Omega$	–	–17	–	dB

Versatile speech/dialler/ringer with
music-on-hold

TEA1069; TEA1069A

SYMBOL	PARAMETER	CONDITIONS	MIN.	TYP.	MAX.	UNIT
AUTOMATIC GAIN CONTROL INPUT AGC (PIN 38)						
ΔG_V	gain control range (controlling the gain from IR to QR and the gain from MIC+, MIC- to LN)	R6 = 110 k Ω (between AGC and V _{EE}); I _{line} = 70 mA	–	–5.8	–	dB
I _{lineH}	highest line current for maximum gain	R6 = 110 k Ω	–	23	–	mA
I _{lineL}	lowest line current for minimum gain	R6 = 110 k Ω	–	61	–	mA
Dialler part						
V _{DD} (PIN 25)						
V _{DD}	supply voltage		2.5	–	6.0	V
V _{DD(MR)}	memory retention voltage		1.0	–	6.0	V
I _{DD}	supply current	DTMF generator off	–	0.3	0.6	mA
		DTMF generator on	–	0.9	1.8	mA
I _{DD(MR)}	memory retention current	standby state, V _{DD} = 1.8 V	–	1.2	–	μ A
V _{POR}	power-on reset trip level		1.5	2.0	2.5	V
INPUTS/OUTPUTS (PINS 9, 12 TO 21, 29 TO 34)						
V _{IL}	LOW level input voltage		0	–	0.3V _{DD}	V
V _{IH}	HIGH level input voltage		0.7V _{DD}	–	V _{DD}	V
I _{IL}	input leakage	V _{EE} < V _I < V _{DD}	–1	–	+1	μ A
I _{OL}	port sink current LOW	V _{DD} = 3 V; V _O = 0.4 V	0.7	8	–	mA
I _{OH}	port pull-up source current HIGH (not valid for pin 33)	V _{DD} = 3 V; V _O = 2.7 V	10	20	–	μ A
		V _{DD} = 3 V; V _O = 0 V	–	100	300	μ A
MUTE (PIN 35)						
I _{OL}	port sink current LOW	V _{DD} = 3 V; V _O = 0.4 V	0.7	8	–	mA
OUTPUTS (PINS 8, 22, 26 TO 28)						
I _{OL}	port sink current LOW	V _{DD} = 3 V; V _O = 0.4 V	0.7	8	–	mA
I _{OH}	port push-pull source current HIGH	V _{DD} = 3 V; V _O = 2.6 V	0.7	4	–	mA
OSCILLATOR (PINS 10 AND 11)						
g _m	transconductance		0.2	0.4	1.0	mA/V
R _f	feedback resistor		0.3	1.0	3.0	M Ω
CE/FDI (PIN 13)						
t _{rd}	reset delay time		–	280	–	ms

Versatile speech/dialler/ringer with
music-on-hold

TEA1069; TEA1069A

SYMBOL	PARAMETER	CONDITIONS	MIN.	TYP.	MAX.	UNIT
KEYBOARD (PINS 14 TO 19 AND 29 TO 33)						
t_d	keyboard debounce time		–	20	–	ms
t_{ap}	access pause time TEA1069	diodes APT off ; APT2 off	–	2	–	s
		diodes APT on ; APT2 off	–	4	–	s
	TEA1069A	diodes APT off ; APT2 off	–	1	–	s
		diodes APT on ; APT2 off	–	4	–	s
		diodes APT off ; APT2 on	–	2	–	s
		diodes APT on ; APT2 on	–	3	–	s
DP/FL OUTPUT (PIN 20)						
t_{idp}	interdigit pause time		–	840	–	ms
$t_{holdover}$	mute hold-over time		–	40	–	ms
$t_{interflash}$	interflash hold-over time	TEA1069	–	0	–	ms
		TEA1069A	–	960	–	ms
t_m	make time	diode M/B off	–	40	–	ms
		diode M/B on	–	33	–	ms
t_b	break time	diode M/B off	–	60	–	ms
		diode M/B on	–	66	–	ms
t_{rc}	recall time using flash	diode FES A off , FES B off	–	100	–	ms
		diode FES A on , FES B off	–	270	–	ms
		diode FES A off , FES B on	–	600	–	ms
t_{ea}	recall time using earth	diode FES A on , FES B on	–	400	–	ms
TONE OUTPUT (PIN 24)						
t_t	burst time	diode TBT off	–	100	–	ms
		diode TBT on	–	85	–	ms
t_p	pause time	diode TBT off	–	100	–	ms
		diode TBT on	–	85	–	ms
$\Delta f/f$	frequency deviation		–0.6		+0.6	%
$V_{HG(rms)}$	HGF voltage (RMS value)		158	181	205	mV
$V_{LG(rms)}$	LGF voltage (RMS value)		125	142	160	mV
V_{DC}	DC voltage level		–	$\frac{1}{2}V_{DD}$	–	V
$ Z_o $	output impedance		–	100	500	Ω
V_G	pre-emphasis of group		1.5	2.0	2.5	dB
THD	total harmonic distortion		–	–25	–	dB

Versatile speech/dialler/ringer with music-on-hold

TEA1069; TEA1069A

SYMBOL	PARAMETER	CONDITIONS	MIN.	TYP.	MAX.	UNIT
Ringer part						
f _{ringL}	ringer detection LOW frequency	diode RFS off (TEA1069); diode RFS on (TEA1069A)	–	40	–	Hz
		diode RFS on (TEA1069); diode RFS off (TEA1069A)	–	29	–	Hz
f _{ringH}	ringer detection HIGH frequency	diode RFS off (TEA1069); diode RFS on (TEA1069A)	–	120	–	Hz
		diode RFS on (TEA1069); diode RFS off (TEA1069A)	–	146	–	Hz
t _{rrd}	ringer response delay	<1.5 frequency cycle	–	–	150	ms

Versatile speech/dialler/ringer with music-on-hold

TEA1069; TEA1069A

APPLICATION INFORMATION

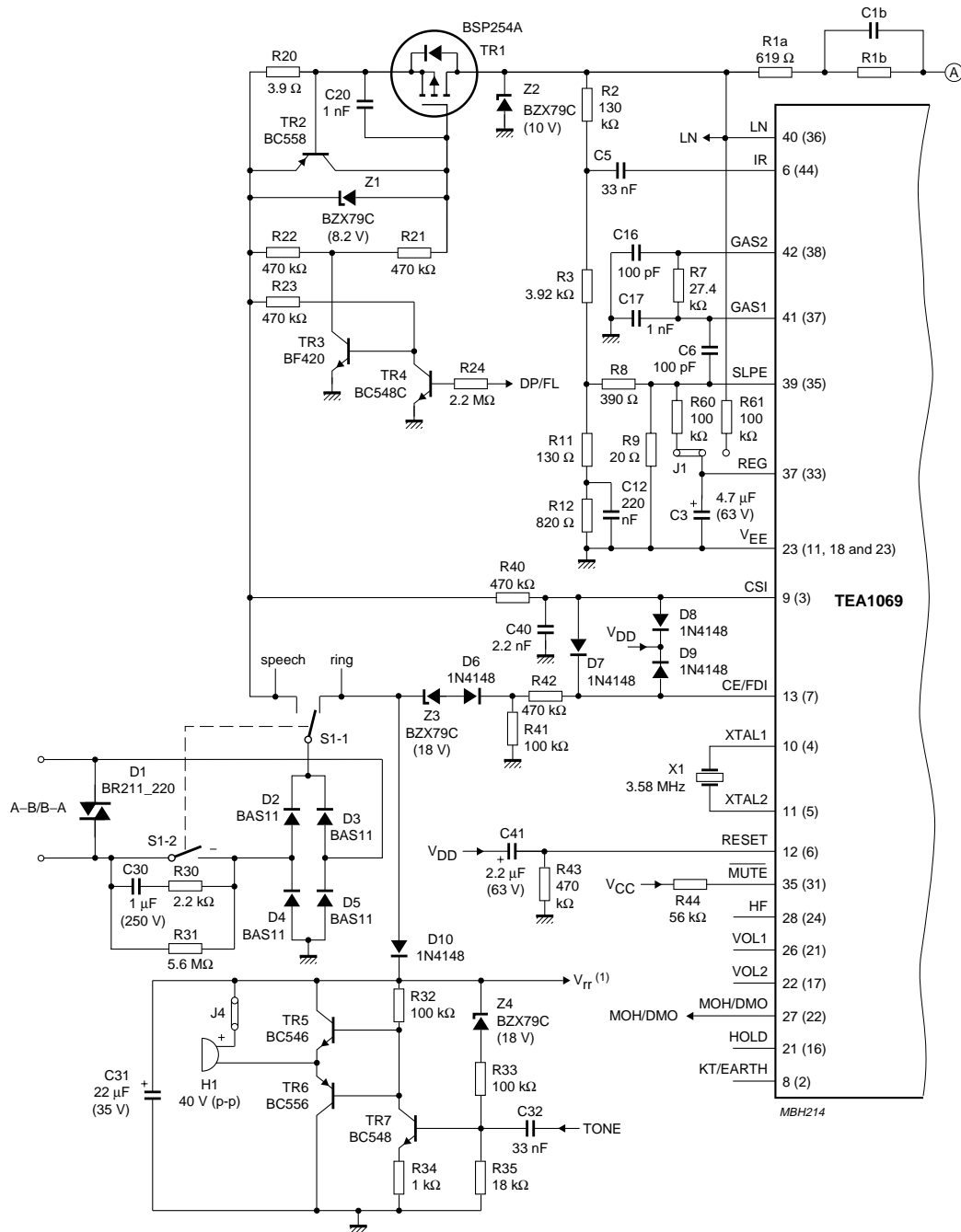

Pin numbers in parenthesis refer to the TEA1069H and TEA1069AH.

(1) Ringer supply voltage.

Fig.28 Basic application diagram (continued in Fig.29).

Versatile speech/dialler/ringer with music-on-hold

TEA1069; TEA1069A

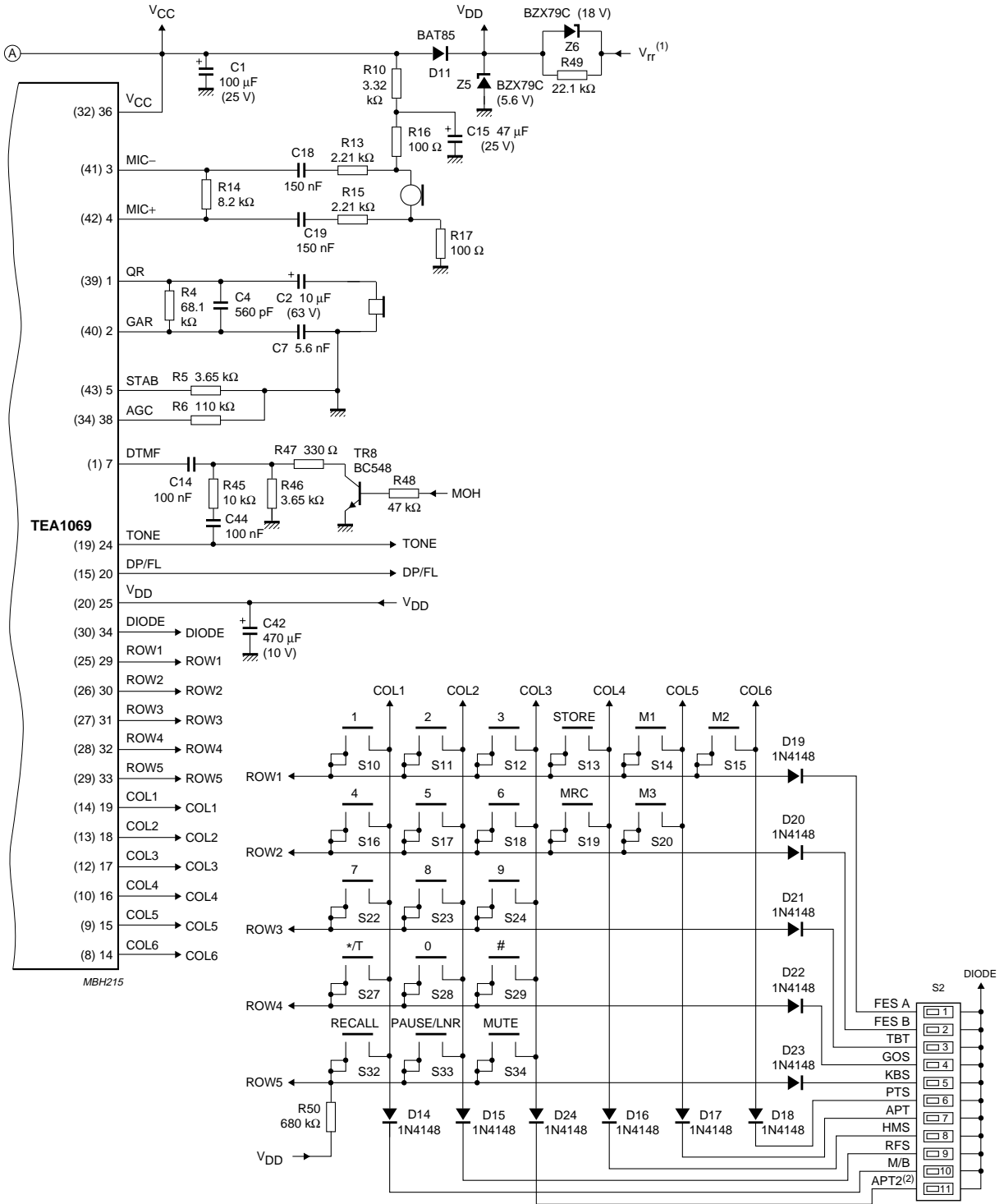

Pin numbers in parenthesis refer to the TEA1069H and TEA1069AH.

(1) Ringer supply voltage.

(2) Only on TEA1069A.

Fig.29 Basic application diagram (continued from Fig.28).

Versatile speech/dialler/ringer with music-on-hold

TEA1069; TEA1069A

PACKAGE OUTLINES

SDIP42: plastic shrink dual in-line package; 42 leads (600 mil)

SOT270-1

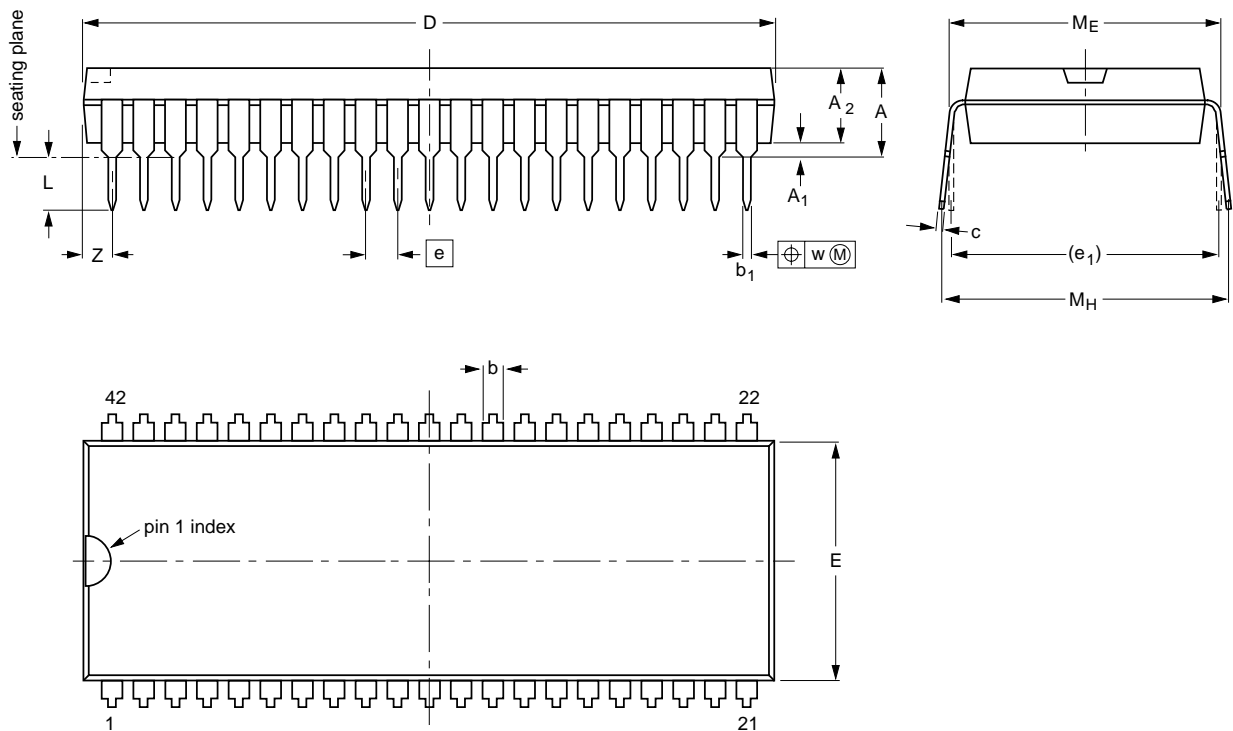

DIMENSIONS (mm are the original dimensions)

UNIT	A max.	A ₁ min.	A ₂ max.	b	b ₁	c	D ⁽¹⁾	E ⁽¹⁾	e	e ₁	L	M _E	M _H	w	z ⁽¹⁾ max.
mm	5.08	0.51	4.0	1.3 0.8	0.53 0.40	0.32 0.23	38.9 38.4	14.0 13.7	1.778	15.24	3.2 2.9	15.80 15.24	17.15 15.90	0.18	1.73

Note

1. Plastic or metal protrusions of 0.25 mm maximum per side are not included.

OUTLINE VERSION	REFERENCES				EUROPEAN PROJECTION	ISSUE DATE
	IEC	JEDEC	EIAJ			
SOT270-1						90-02-13 95-02-04

Versatile speech/dialler/ringer with music-on-hold

TEA1069; TEA1069A

QFP44: plastic quad flat package; 44 leads (lead length 1.3 mm); body 10 x 10 x 1.75 mm

SOT307-2

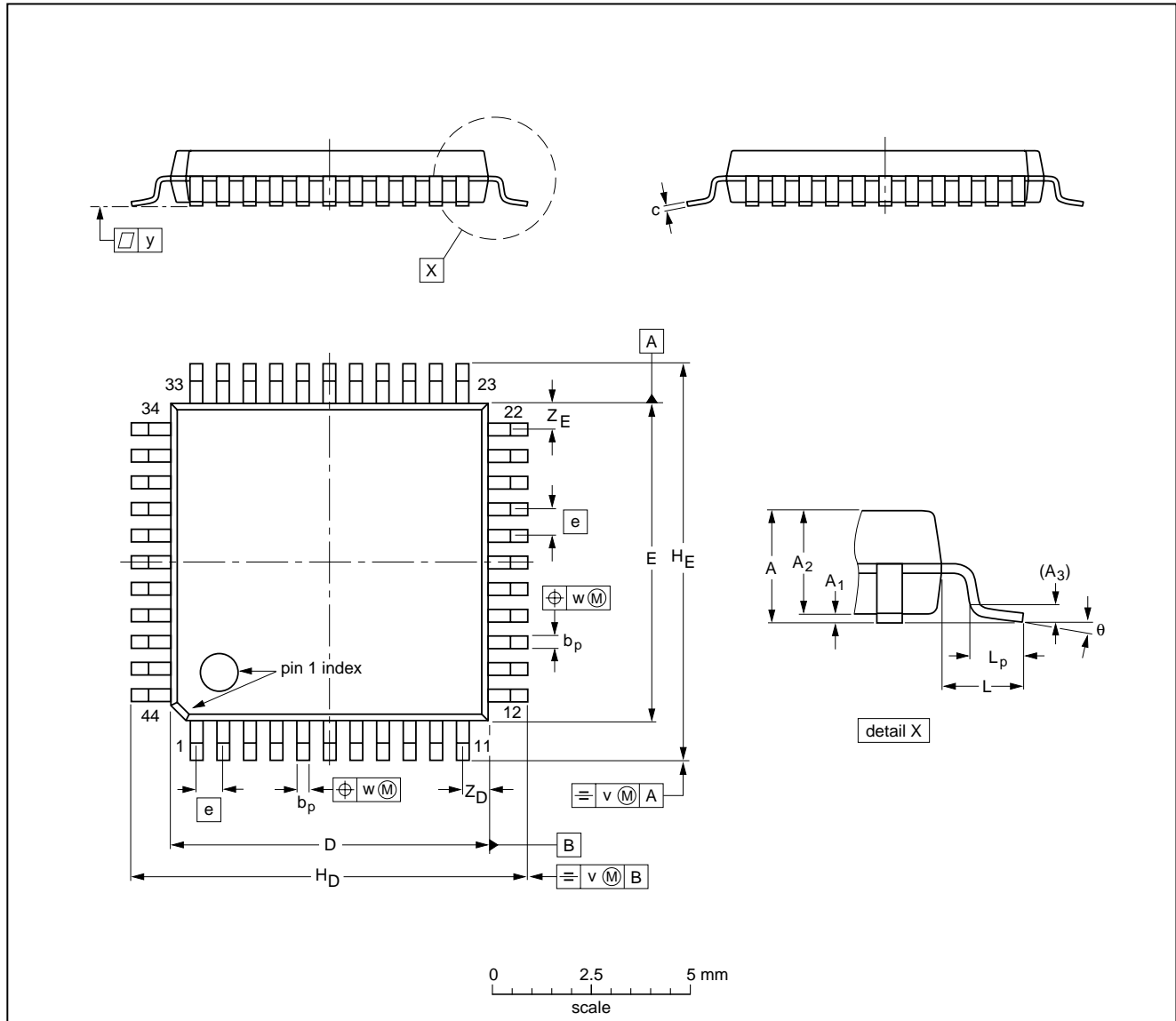

DIMENSIONS (mm are the original dimensions)

UNIT	A max.	A ₁	A ₂	A ₃	b _p	c	D ⁽¹⁾	E ⁽¹⁾	e	H _D	H _E	L	L _p	v	w	y	Z _D ⁽¹⁾	Z _E ⁽¹⁾	θ
mm	2.10	0.25 0.05	1.85 1.65	0.25	0.40 0.20	0.25 0.14	10.1 9.9	10.1 9.9	0.8	12.9 12.3	12.9 12.3	1.3	0.95 0.55	0.15	0.15	0.1	1.2 0.8	1.2 0.8	10° 0°

Note

1. Plastic or metal protrusions of 0.25 mm maximum per side are not included.

OUTLINE VERSION	REFERENCES				EUROPEAN PROJECTION	ISSUE DATE
	IEC	JEDEC	EIAJ			
SOT307-2						95-02-04 97-08-01

Versatile speech/dialler/ringer with music-on-hold

TEA1069; TEA1069A

SOLDERING

Introduction

There is no soldering method that is ideal for all IC packages. Wave soldering is often preferred when through-hole and surface mounted components are mixed on one printed-circuit board. However, wave soldering is not always suitable for surface mounted ICs, or for printed-circuits with high population densities. In these situations reflow soldering is often used.

This text gives a very brief insight to a complex technology. A more in-depth account of soldering ICs can be found in our "IC Package Databook" (order code 9398 652 90011).

SDIP

SOLDERING BY DIPPING OR BY WAVE

The maximum permissible temperature of the solder is 260 °C; solder at this temperature must not be in contact with the joint for more than 5 seconds. The total contact time of successive solder waves must not exceed 5 seconds.

The device may be mounted up to the seating plane, but the temperature of the plastic body must not exceed the specified maximum storage temperature ($T_{stg\ max}$). If the printed-circuit board has been pre-heated, forced cooling may be necessary immediately after soldering to keep the temperature within the permissible limit.

REPAIRING SOLDERED JOINTS

Apply a low voltage soldering iron (less than 24 V) to the lead(s) of the package, below the seating plane or not more than 2 mm above it. If the temperature of the soldering iron bit is less than 300 °C it may remain in contact for up to 10 seconds. If the bit temperature is between 300 and 400 °C, contact may be up to 5 seconds.

QFP

REFLOW SOLDERING

Reflow soldering techniques are suitable for all QFP packages.

The choice of heating method may be influenced by larger plastic QFP packages (44 leads, or more). If infrared or vapour phase heating is used and the large packages are not absolutely dry (less than 0.1% moisture content by weight), vaporization of the small amount of moisture in them can cause cracking of the plastic body. For more information, refer to the Drypack chapter in our "Quality Reference Handbook" (order code 9397 750 00192).

Reflow soldering requires solder paste (a suspension of fine solder particles, flux and binding agent) to be applied to the printed-circuit board by screen printing, stencilling or pressure-syringe dispensing before package placement.

Several methods exist for reflowing; for example, infrared/convection heating in a conveyor type oven. Throughput times (preheating, soldering and cooling) vary between 50 and 300 seconds depending on heating method. Typical reflow peak temperatures range from 215 to 250 °C.

WAVE SOLDERING

Wave soldering is **not** recommended for QFP packages. This is because of the likelihood of solder bridging due to closely-spaced leads and the possibility of incomplete solder penetration in multi-lead devices.

CAUTION

Wave soldering is NOT applicable for all QFP packages with a pitch (e) equal or less than 0.5 mm.

If wave soldering cannot be avoided, for QFP packages with a pitch (e) larger than 0.5 mm, the following conditions must be observed:

- **A double-wave (a turbulent wave with high upward pressure followed by a smooth laminar wave) soldering technique should be used.**
- **The footprint must be at an angle of 45° to the board direction and must incorporate solder thieves downstream and at the side corners.**

During placement and before soldering, the package must be fixed with a droplet of adhesive. The adhesive can be applied by screen printing, pin transfer or syringe dispensing. The package can be soldered after the adhesive is cured. Maximum permissible solder temperature is 260 °C, and maximum duration of package immersion in solder is 10 seconds, if cooled to less than 150 °C within 6 seconds. Typical dwell time is 4 seconds at 250 °C. A mildly-activated flux will eliminate the need for removal of corrosive residues in most applications.

REPAIRING SOLDERED JOINTS

Fix the component by first soldering two diagonally-opposite end leads. Use only a low voltage soldering iron (less than 24 V) applied to the flat part of the lead. Contact time must be limited to 10 seconds at up to 300 °C. When using a dedicated tool, all other leads can be soldered in one operation within 2 to 5 seconds between 270 and 320 °C.

Versatile speech/dialler/ringer with music-on-hold

TEA1069; TEA1069A

DEFINITIONS

Data sheet status	
Objective specification	This data sheet contains target or goal specifications for product development.
Preliminary specification	This data sheet contains preliminary data; supplementary data may be published later.
Product specification	This data sheet contains final product specifications.
Limiting values	
Limiting values given are in accordance with the Absolute Maximum Rating System (IEC 134). Stress above one or more of the limiting values may cause permanent damage to the device. These are stress ratings only and operation of the device at these or at any other conditions above those given in the Characteristics sections of the specification is not implied. Exposure to limiting values for extended periods may affect device reliability.	
Application information	
Where application information is given, it is advisory and does not form part of the specification.	

LIFE SUPPORT APPLICATIONS

These products are not designed for use in life support appliances, devices, or systems where malfunction of these products can reasonably be expected to result in personal injury. Philips customers using or selling these products for use in such applications do so at their own risk and agree to fully indemnify Philips for any damages resulting from such improper use or sale.

Versatile speech/dialler/ringer with
music-on-hold

TEA1069; TEA1069A

NOTES

Versatile speech/dialler/ringer with
music-on-hold

TEA1069; TEA1069A

NOTES

Philips Semiconductors – a worldwide company

Argentina: see South America

Australia: 34 Waterloo Road, NORTH RYDE, NSW 2113,
Tel. +61 2 9805 4455, Fax. +61 2 9805 4466

Austria: Computerstr. 6, A-1101 WIEN, P.O. Box 213, Tel. +43 160 1010,
Fax. +43 160 101 1210

Belarus: Hotel Minsk Business Center, Bld. 3, r. 1211, Volodarski Str. 6,
220050 MINSK, Tel. +375 172 200 733, Fax. +375 172 200 773

Belgium: see The Netherlands

Brazil: see South America

Bulgaria: Philips Bulgaria Ltd., Energoproject, 15th floor,
51 James Bourchier Blvd., 1407 SOFIA,
Tel. +359 2 689 211, Fax. +359 2 689 102

Canada: PHILIPS SEMICONDUCTORS/COMPONENTS,
Tel. +1 800 234 7381

China/Hong Kong: 501 Hong Kong Industrial Technology Centre,
72 Tat Chee Avenue, Kowloon Tong, HONG KONG,
Tel. +852 2319 7888, Fax. +852 2319 7700

Colombia: see South America

Czech Republic: see Austria

Denmark: Prags Boulevard 80, PB 1919, DK-2300 COPENHAGEN S,
Tel. +45 32 88 2636, Fax. +45 31 57 0044

Finland: Sinikalliontie 3, FIN-02630 ESPOO,
Tel. +358 9 615800, Fax. +358 9 61580920

France: 51 Rue Carnot, BP317, 92156 SURESNES Cedex,
Tel. +33 1 40 99 6161, Fax. +33 1 40 99 6427

Germany: Hammerbrookstraße 69, D-20097 HAMBURG,
Tel. +49 40 23 53 60, Fax. +49 40 23 536 300

Greece: No. 15, 25th March Street, GR 17778 TAVROS/ATHENS,
Tel. +30 1 4894 339/239, Fax. +30 1 4814 240

Hungary: see Austria

India: Philips INDIA Ltd, Band Box Building, 2nd floor,
254-D, Dr. Annie Besant Road, Worli, MUMBAI 400 025,
Tel. +91 22 493 8541, Fax. +91 22 493 0966

Indonesia: see Singapore

Ireland: Newstead, Clonskeagh, DUBLIN 14,
Tel. +353 1 7640 000, Fax. +353 1 7640 200

Israel: RAPAC Electronics, 7 Kehilat Saloniki St, PO Box 18053,
TEL AVIV 61180, Tel. +972 3 645 0444, Fax. +972 3 649 1007

Italy: PHILIPS SEMICONDUCTORS, Piazza IV Novembre 3,
20124 MILANO, Tel. +39 2 6752 2531, Fax. +39 2 6752 2557

Japan: Philips Bldg 13-37, Kohnan 2-chome, Minato-ku, TOKYO 108,
Tel. +81 3 3740 5130, Fax. +81 3 3740 5077

Korea: Philips House, 260-199 Itaewon-dong, Yongsan-ku, SEOUL,
Tel. +82 2 709 1412, Fax. +82 2 709 1415

Malaysia: No. 76 Jalan Universiti, 46200 PETALING JAYA, SELANGOR,
Tel. +60 3 750 5214, Fax. +60 3 757 4880

Mexico: 5900 Gateway East, Suite 200, EL PASO, TEXAS 79905,
Tel. +9-5 800 234 7381

Middle East: see Italy

Netherlands: Postbus 90050, 5600 PB EINDHOVEN, Bldg. VB,
Tel. +31 40 27 82785, Fax. +31 40 27 88399

New Zealand: 2 Wagener Place, C.P.O. Box 1041, AUCKLAND,
Tel. +64 9 849 4160, Fax. +64 9 849 7811

Norway: Box 1, Manglerud 0612, OSLO,
Tel. +47 22 74 8000, Fax. +47 22 74 8341

Philippines: Philips Semiconductors Philippines Inc.,
106 Valero St. Salcedo Village, P.O. Box 2108 MCC, MAKATI,
Metro MANILA, Tel. +63 2 816 6380, Fax. +63 2 817 3474

Poland: Ul. Lukiska 10, PL 04-123 WARSZAWA,
Tel. +48 22 612 2831, Fax. +48 22 612 2327

Portugal: see Spain

Romania: see Italy

Russia: Philips Russia, Ul. Usatcheva 35A, 119048 MOSCOW,
Tel. +7 095 755 6918, Fax. +7 095 755 6919

Singapore: Lorong 1, Toa Payoh, SINGAPORE 1231,
Tel. +65 350 2538, Fax. +65 251 6500

Slovakia: see Austria

Slovenia: see Italy

South Africa: S.A. PHILIPS Pty Ltd., 195-215 Main Road Martindale,
2092 JOHANNESBURG, P.O. Box 7430 Johannesburg 2000,
Tel. +27 11 470 5911, Fax. +27 11 470 5494

South America: Al. Vicente Pinzon, 173, 6th floor,
04547-130 SÃO PAULO, SP, Brazil,
Tel. +55 11 821 2333, Fax. +55 11 821 2382

Spain: Balmes 22, 08007 BARCELONA,
Tel. +34 3 301 6312, Fax. +34 3 301 4107

Sweden: Kottbygatan 7, Akalla, S-16485 STOCKHOLM,
Tel. +46 8 632 2000, Fax. +46 8 632 2745

Switzerland: Allmendstrasse 140, CH-8027 ZÜRICH,
Tel. +41 1 488 2686, Fax. +41 1 488 3263

Taiwan: Philips Semiconductors, 6F, No. 96, Chien Kuo N. Rd., Sec. 1,
TAIPEI, Taiwan Tel. +886 2 2134 2865, Fax. +886 2 2134 2874

Thailand: PHILIPS ELECTRONICS (THAILAND) Ltd.,
209/2 Sanpavuth-Bangna Road Prakanong, BANGKOK 10260,
Tel. +66 2 745 4090, Fax. +66 2 398 0793

Turkey: Talatpasa Cad. No. 5, 80640 GÜLTEPE/ISTANBUL,
Tel. +90 212 279 2770, Fax. +90 212 282 6707

Ukraine: PHILIPS UKRAINE, 4 Patrice Lumumba str., Building B, Floor 7,
252042 KIEV, Tel. +380 44 264 2776, Fax. +380 44 268 0461

United Kingdom: Philips Semiconductors Ltd., 276 Bath Road, Hayes,
MIDDLESEX UB3 5BX, Tel. +44 181 730 5000, Fax. +44 181 754 8421

United States: 811 East Arques Avenue, SUNNYVALE, CA 94088-3409,
Tel. +1 800 234 7381

Uruguay: see South America

Vietnam: see Singapore

Yugoslavia: PHILIPS, Trg N. Pasica 5/v, 11000 BEOGRAD,
Tel. +381 11 625 344, Fax. +381 11 635 777

For all other countries apply to: Philips Semiconductors,
International Marketing & Sales Communications, Building BE-p, P.O. Box 218,
5600 MD EINDHOVEN, The Netherlands, Fax. +31 40 27 24825

Internet: <http://www.semiconductors.philips.com>

© Philips Electronics N.V. 1998

SCA57

All rights are reserved. Reproduction in whole or in part is prohibited without the prior written consent of the copyright owner.

The information presented in this document does not form part of any quotation or contract, is believed to be accurate and reliable and may be changed without notice. No liability will be accepted by the publisher for any consequence of its use. Publication thereof does not convey nor imply any license under patent- or other industrial or intellectual property rights.

Printed in The Netherlands

417027/1200/04/pp44

Date of release: 1998 Jan 08

Document order number: 9397 750 03133

Let's make things better.

**Philips
Semiconductors**



PHILIPS