

# DATA SHEET

## **TEA1081**

Supply circuit with power-down for  
telephone set peripherals

Product specification  
Supersedes data of February 1988  
File under Integrated Circuits, IC03

September 1994

**Philips Semiconductors**



**PHILIPS**

## Supply circuit with power-down for telephone set peripherals

## TEA1081

### FEATURES

- High input impedance for audio signals
- Low DC series resistance
- High output current
- Large audio signal handling capability
- Low distortion
- Two modes of operation:
  - output voltage that follows the DC line voltage
  - regulated output voltage
- Power-down input
- Low number of external components.

### GENERAL DESCRIPTION

The TEA1081 is an integrated circuit for use in line-powered telephone sets to supply peripheral circuits for extended dialling and/or loudspeaker facilities.

The IC uses a part of the surplus line current normally drawn by the voltage regulator of the speech/transmission circuit. A power-down function isolates the IC from its load and reduces the input current.

### QUICK REFERENCE DATA

SYMBOL	PARAMETER	CONDITIONS	MIN.	TYP.	MAX.	UNIT
$V_{LN}$	operating DC line voltage		2.5	–	12.0	V
$V_O$	DC output voltage		2.0	–	10.0	V
$\Delta V_{LN-O}$	voltage drop from line to output	$I_O = 0$ mA	–	0.5	–	V
$R_S$	internal series resistance		–	20	–	$\Omega$
$I_O$	output current (pin 7) TEA1081 TEA1081T	$V_{LN} = 4$ V	–	–	30 20	mA mA
$V_{LN(rms)}$	AC line voltage (RMS value)	$V_{LN} = 4$ V; $I_O = 15$ mA; THD = 2%	–	1.5	–	V
$I_{INT}$	internal supply current	$V_{LN} = 4$ V; $I_O = 0$ mA; PD = LOW; $V_{SP} = V_O$	–	0.8	1.4	mA
$T_{amb}$	operating ambient temperature		–25	–	+70	$^{\circ}\text{C}$

### ORDERING INFORMATION

TYPE NUMBER	PACKAGE		
	NAME	DESCRIPTION	VERSION
TEA1081	DIP8	plastic dual in-line package; 8 leads (300 mil)	SOT97-1
TEA1081T	SO8	plastic small outline package; 8 leads; body width 3.9 mm	SOT96-1

# Supply circuit with power-down for telephone set peripherals

TEA1081

## BLOCK DIAGRAM

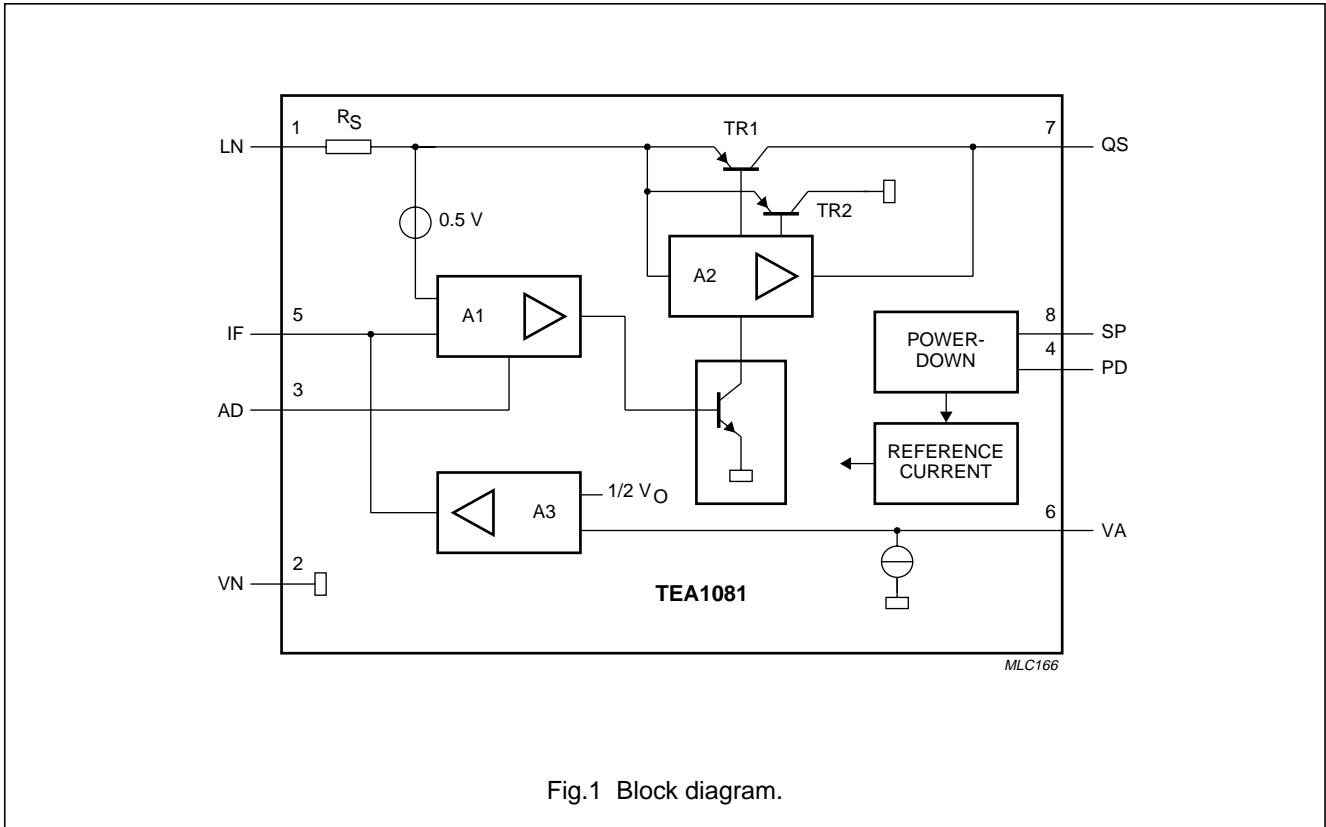

## PINNING

SYMBOL	PIN	DESCRIPTION
LN	1	positive line terminal
VN	2	negative line terminal
AD	3	amplifier decoupling
PD	4	power-down input
IF	5	low-pass filter input
VA	6	output voltage adjustment
QS	7	power supply output
SP	8	supply input; power-down circuit

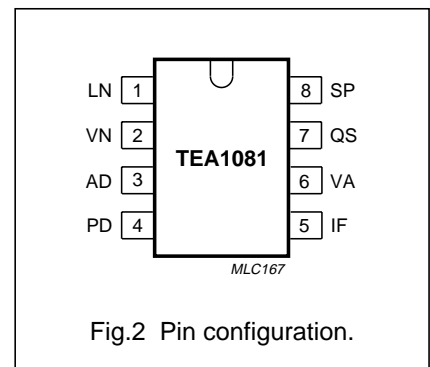

# Supply circuit with power-down for telephone set peripherals

TEA1081

## FUNCTIONAL DESCRIPTION

The TEA1081 is a supply interface between telephone line and peripheral devices in the telephone set. The high input impedance of the circuit allows direct connection to the telephone line (via a diode bridge). An inductor function is obtained by amplifier A1, resistor R<sub>S</sub> (see Fig.1) and an external low-pass RC filter.

Under the control of amplifier A2, transistor TR1 supplies peripheral devices and transistor TR2 minimizes line signal distortion by momentarily diverting input current to ground whenever the instantaneous value of the line voltage drops below the output voltage.

Internal circuits are biased by a temperature and line voltage compensated reference current source.

The power-down circuit isolates the supply circuit from external circuitry.

### Line terminals: LN and VN (pins 1 and 2)

The input terminals LN and VN can be connected directly to the line. The minimum DC line voltage required at the input is expressed by formula (1); see also Table 1.

$$V_{LN} = I_1 \times R_S + V_{LNmin} + V_{LN(P)} \quad (1)$$

**Table 1** Explanation of formula (1).

SYMBOL	DESCRIPTION
I <sub>1</sub>	input current
R <sub>S</sub>	internal series resistance
V <sub>LNmin</sub>	minimum instantaneous line voltage (1.4 V at I <sub>O</sub> = 5 mA)
V <sub>LN(P)</sub>	required peak level of AC line voltage

The internal current (I<sub>INT</sub>) at I<sub>O</sub> = 0 mA is typically 0.8 mA at V<sub>LN</sub> = 4 V and reaches a maximum of 1.4 mA at V<sub>LN</sub> = 12 V.

### Supply terminals: QS and VA (pins 7 and 6)

Peripheral devices are supplied from QS (pin 7). Two modes of output voltage regulation are available.

#### OUTPUT VOLTAGE FOLLOWS LINE VOLTAGE (SEE FIG.3)

The TEA1081 operates in this mode when there is no external resistor (R<sub>V</sub>) between QS and VA (see Fig.6).

The output voltage follows the line voltage and is expressed by formula (2); see also Table 2.

$$V_O = V_{LN} - (I_1 \times R_S + 0.5) \quad (2)$$

**Table 2** Explanation of formula (2).

SYMBOL	DESCRIPTION
V <sub>LN</sub>	line voltage
I <sub>1</sub>	input current
R <sub>S</sub>	internal series resistance

#### REGULATED OUTPUT VOLTAGE (SEE FIG.4)

The circuit operates in this mode when an external resistor (R<sub>V</sub>) is connected between QS and VA (see Fig.6).

The output voltage is held constant at V<sub>O</sub> = 2 × I<sub>6</sub> × R<sub>V</sub> (V) as soon as the line voltage

$$V_{LN} > (2 \times I_6 \times R_V + I_1 \times R_S + 0.5) \quad (V)$$

The control current I<sub>6</sub> is typically 20 μA.

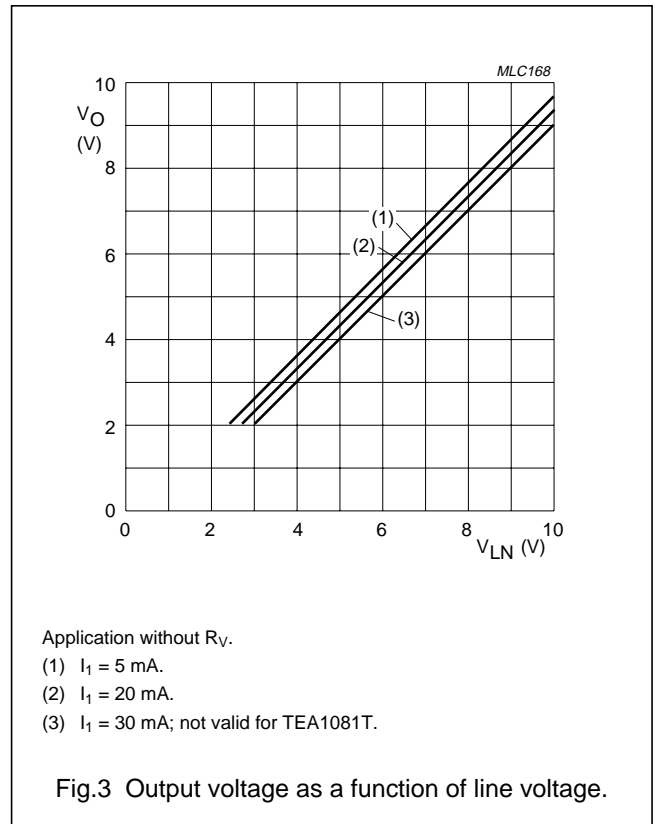

# Supply circuit with power-down for telephone set peripherals

TEA1081

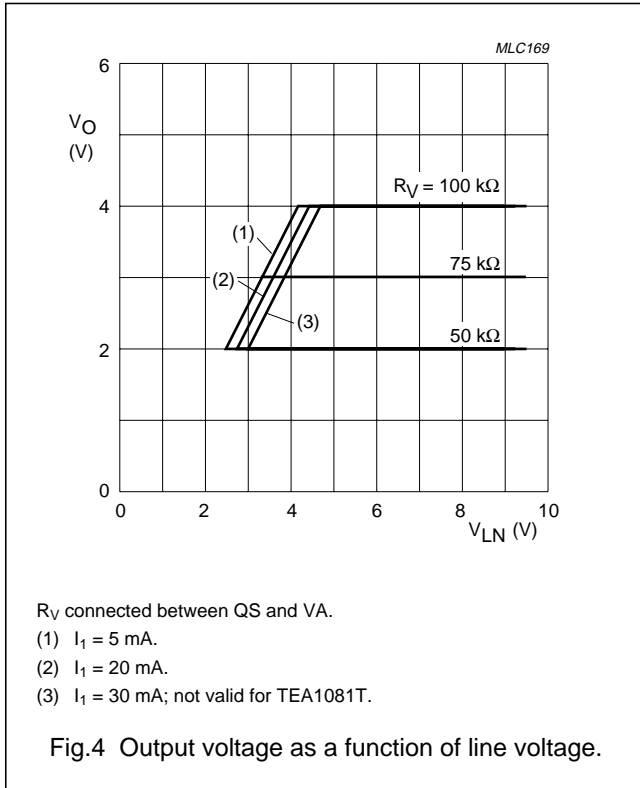

## Input and output currents $I_1$ and $I_O$ (pins 1 and 7)

The maximum available current into pin 1 ( $I_1$ ) is determined by:

- The minimum line current ( $I_{LINEmin}$ ) that is available for the telephone set
- The specified minimum input current ( $I_{LNmin}$ ) for the speech/transmission circuit.

That is  $I_{1max} = I_{LINEmin} - I_{LNmin}$ .

At  $V_{LN(rms)} < 150\text{ mV}$ , the input current  $I_1$  is approximately:

$$I_1 = I_{INT} + k \times I_O \text{ (mA)}$$

Where:

- $I_{INT}$  = internal supply current (0.8 mA at  $V_{LN} = 4\text{ V}$ );
- $k$  = correction factor ( $k < 1.1$  for the specified output current range).

With large line signals the instantaneous line voltage may drop below  $V_O + 0.4\text{ V}$ . Normally (when  $V_{LN} > V_O + 0.4\text{ V}$ ), instantaneous current flows from LN to QS (pin 1 to pin 7) to the output load.

When  $V_{LN} < V_O + 0.4\text{ V}$ , the instantaneous current is diverted to pin 2 to prevent distortion of the line signal.

Input current at  $V_{LN(rms)} = 1\text{ V}$  and without  $R_V$  approximates to:

$$I_1 = I_{INT} + 2 \times I_O \text{ (mA)}$$

The maximum supply current (within the specified output current limits) available for peripheral devices is shown by:

$$I_{Omax} = \frac{I_{LINEmin} - I_{LNmin} - I_{INT}}{2}$$

Where:

- $I_{LINEmin}$  is the minimum line current of the telephone set;
- $I_{LNmin}$  is the specified minimum input current of the speech/transmission circuit.

## Input low-pass filter: IF (pin 5)

The input impedance between LN and VN at audio frequencies is determined by the filter elements  $C_L$  (between pins 1 and 5),  $R_L$  (between pins 5 and 7) and the internal resistor  $R_S$  (typical value  $20\ \Omega$ ).

At audio frequencies the TEA1081 behaves as an inductor of the value  $L_1 = C_L \times R_L \times R_S$  (H). The typical value of  $L_1$  at  $C_L = 2.2\ \mu\text{F}$  and  $R_L = 100\text{ k}\Omega$  is 4.4 H.

## Amplifier decoupling: AD (pin 3)

To ensure stability, a 68 pF decoupling capacitor is required between AD (pin 3) and LN (pin 1).

If  $I_{Omin} < 1.5\text{ mA}$ , a 47 pF capacitor has to be added between AD (pin 3) and VA (pin 6).

## Power-down inputs: PD and SP (pins 4 and 8)

During pulse dialling or register recall, or if the input current to pin 1 is insufficient to maintain the output current, the supply to peripheral devices can be switched off by activating the PD input at pin 4. With PD = HIGH, the input current is reduced to  $40\ \mu\text{A}$  (typ.) at  $V_{LN} = 4\text{ V}$  and the internal circuits are isolated from the load at QS (pin 7).

The power-down circuit is supplied via the SP input (pin 8). SP can be wired to QS in conditions where  $V_O > V_{SPmin}$  during line interruptions. When  $V_O < V_{SPmin}$ , SP should be wired to an external supply point (e.g. to  $V_{CC}$  of the TEA1060 family circuit).

When power-down is not required, the PD and SP inputs can be left open-circuit.

# Supply circuit with power-down for telephone set peripherals

TEA1081

## LIMITING VALUES

In accordance with the Absolute Maximum Rating System (IEC 134).

SYMBOL	PARAMETER	CONDITIONS	MIN.	MAX.	UNIT
V <sub>LN</sub>	positive line voltage	continuous	–	12	V
		during switch-on or line interruptions	–	12.5	V
V <sub>LN(RM)</sub>	repetitive peak line voltage for a 1 ms pulse per 5 s	12 Ω resistor in series with pin 1	–	28	V
V <sub>I</sub>	input voltage (all other terminals)		V <sub>VN</sub> – 0.5	V <sub>LN</sub> + 0.5	V
I <sub>I</sub>	DC input current TEA1081 TEA1081T		–	120	mA
			–	80	mA
I <sub>I</sub>	input current (all other terminals)		–1	+1	mA
P <sub>tot</sub>	total power dissipation		see Fig.5		
T <sub>amb</sub>	operating ambient temperature		–25	+70	°C
T <sub>stg</sub>	storage temperature		–40	+125	°C
T <sub>j</sub>	junction temperature		–	+125	°C

## THERMAL CHARACTERISTICS

SYMBOL	PARAMETER	VALUE	UNIT
R <sub>th j-a</sub>	thermal resistance from junction to ambient in free air		
	TEA1081	120	K/W
	TEA1081T (mounted on a printed-circuit board of 50 × 50 × 1.5 mm)	260	K/W

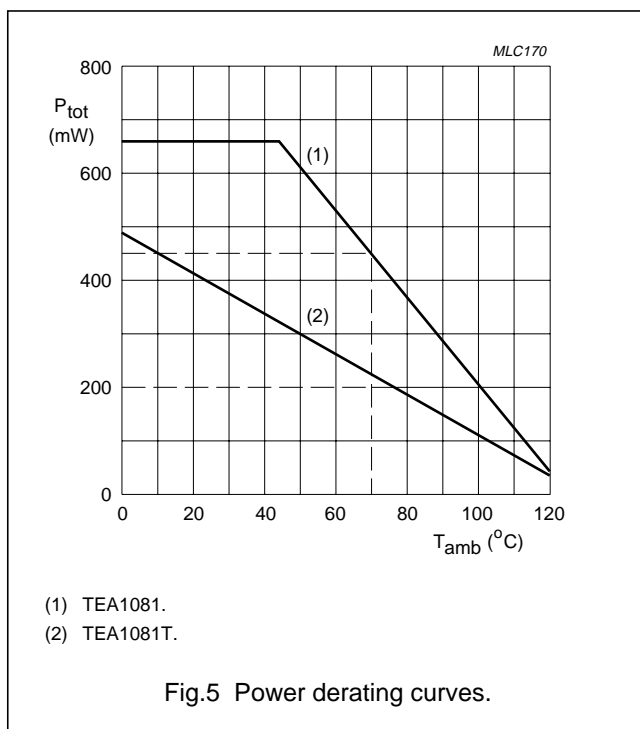

## Supply circuit with power-down for telephone set peripherals

TEA1081

### CHARACTERISTICS

$V_{LN} = 4\text{ V}$ ;  $V_{LN(rms)} = 100\text{ mV}$ ;  $I_O = 5\text{ mA}$ ;  $f = 300\text{ to }3400\text{ Hz}$ ;  $R_L = 100\text{ k}\Omega$ ;  $C_L = 2.2\text{ }\mu\text{F}$ ;  $R_V = 75\text{ k}\Omega$ ;  $T_{amb} = 25\text{ }^\circ\text{C}$ ; unless otherwise specified; see Fig.6.

SYMBOL	PARAMETER	CONDITIONS	MIN.	TYP.	MAX.	UNIT	
$V_{LN}$	operating DC line voltage		2.5	–	12.0	V	
$V_{LNmin}$	minimum instantaneous line voltage		–	–	1.4	V	
$V_{LNmax}$	maximum instantaneous line voltage		12.0	–	–	V	
<b>Characteristics with <math>R_V = 75\text{ k}\Omega</math> connected between pins 6 and 7 and <math>C_L = 10\text{ }\mu\text{F}</math></b>							
$I_1$	input current (pin 1)	$V_{LN(rms)} = 0\text{ V}$	–	5.8	–	mA	
		$V_{LN(rms)} = 1.5\text{ V}$ ; $I_O = 15\text{ mA}$	–	30	–	mA	
$V_O$	output voltage (pin 7)		–	3.0	–	V	
$\Delta V_O$	variation of output voltage over the ranges of:	line voltage	$V_{LN} = 4\text{ to }6\text{ V}$	–	100	–	mV
		temperature	$T_{amb} = +25\text{ to }-25\text{ }^\circ\text{C}$	–	–100	–	mV
		temperature	$T_{amb} = +25\text{ to }+75\text{ }^\circ\text{C}$	–	–100	–	mV
		output current	$I_O = 5\text{ to }20\text{ mA}$	–	–100	–	mV
$I_6$	control current (pin 6)		–	20	–	$\mu\text{A}$	
<b>Characteristics without <math>R_V</math></b>							
$I_1$	input current (pin 1)	$V_{LN(rms)} = 0\text{ V}$	–	6.0	–	mA	
		$V_{LN(rms)} = 1.5\text{ V}$ ; $I_O = 15\text{ mA}$	–	31	–	mA	
$\Delta V_{LN-O}$	voltage drop from line to output	$I_O = 0\text{ mA}$	–	0.5	–	V	
		$I_O = 15\text{ mA}$ ; $V_{LN(rms)} = 1.5\text{ V}$	–	1.1	–	V	
$I_O$	output current (pin 7)	TEA1081	–	–	30	mA	
		TEA1081T	–	–	20	mA	
$R_S$	internal series resistance		–	20	–	$\Omega$	
$I_{INT}$	internal supply current	$I_O = 0\text{ mA}$ ; PD = LOW; $V_{SP} = V_O$	–	0.8	1.4	mA	
		$I_O = 0\text{ mA}$ ; PD = HIGH (note 1); $V_{SP} > 2\text{ V}$	–	40	60	$\mu\text{A}$	
THD	total harmonic distortion	$V_{LN(rms)} = 1.5\text{ V}$	–	–	2	%	
BRL	balance return loss	600 $\Omega$ reference	25	–	–	dB	
$V_{LN(2H)}$	second harmonic level of line voltage	$f = 500\text{ Hz}$ ; $V_{LN} = 0\text{ dBm}$ ; $Z_{line} = 600\text{ }\Omega$	–	–58	–	dBm	
$V_{LN(3H)}$	third harmonic level of line voltage	$f = 500\text{ Hz}$ ; $V_{LN} = 0\text{ dBm}$ ; $Z_{line} = 600\text{ }\Omega$	–	–60	–	dBm	
$V_{ni(rms)}$	noise voltage on input terminal (RMS value)	$V_{LN(rms)} = 0\text{ V}$ ; $R_L = 600\text{ }\Omega$ ; P53 curve	–	–83	–	dBmp	
<b>Power-down input (pin 4)</b>							
$V_{IL}$	LOW level input voltage		–	–	0.3	V	
$V_{IH}$	HIGH level input voltage		1.5	–	$V_{SP}$	V	
$I_4$	input current		–	–	10	$\mu\text{A}$	

# Supply circuit with power-down for telephone set peripherals

TEA1081

SYMBOL	PARAMETER	CONDITIONS	MIN.	TYP.	MAX.	UNIT
<b>Power-down input (pin 8)</b>						
$V_8$	supply voltage for power-down		2	–	$V_{LN}$	V
$I_8$	supply current to power-down circuit	$V_8 = 3\text{ V}$	–	–	70	$\mu\text{A}$

**Note**

1. Power-down circuit supplied via external source.

**APPLICATION INFORMATION**

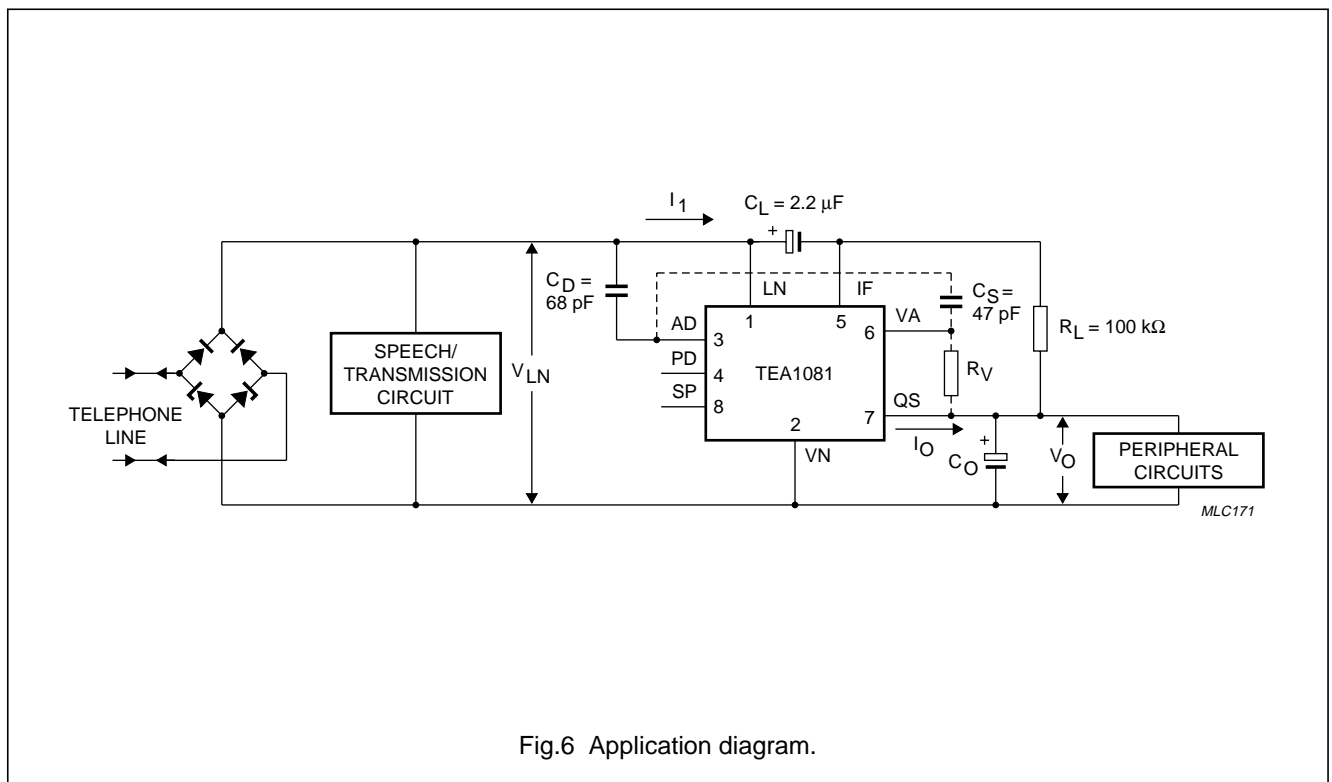

Fig.6 Application diagram.



# Supply circuit with power-down for telephone set peripherals

TEA1081

## PACKAGE OUTLINES

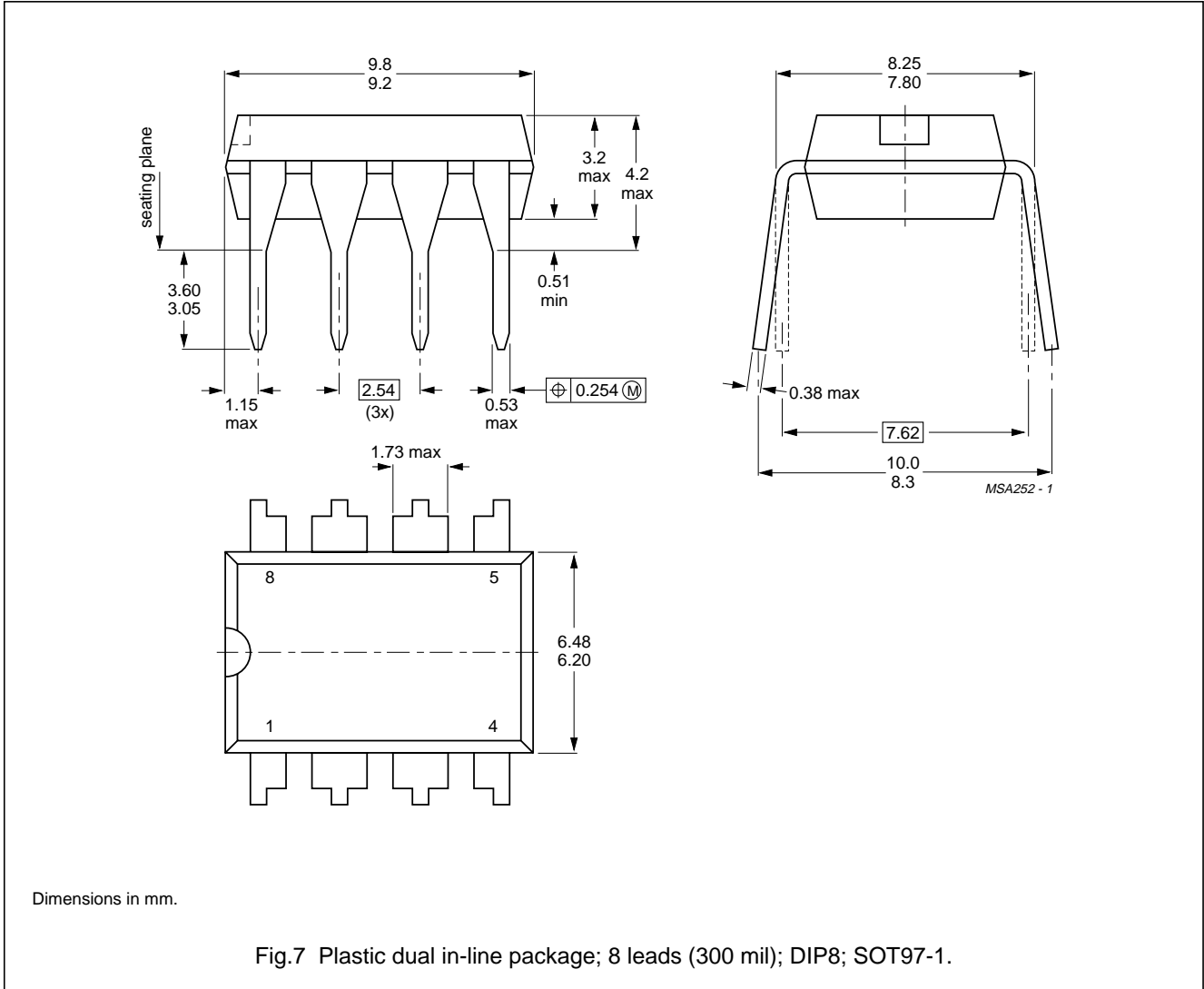

Supply circuit with power-down for  
telephone set peripherals

TEA1081

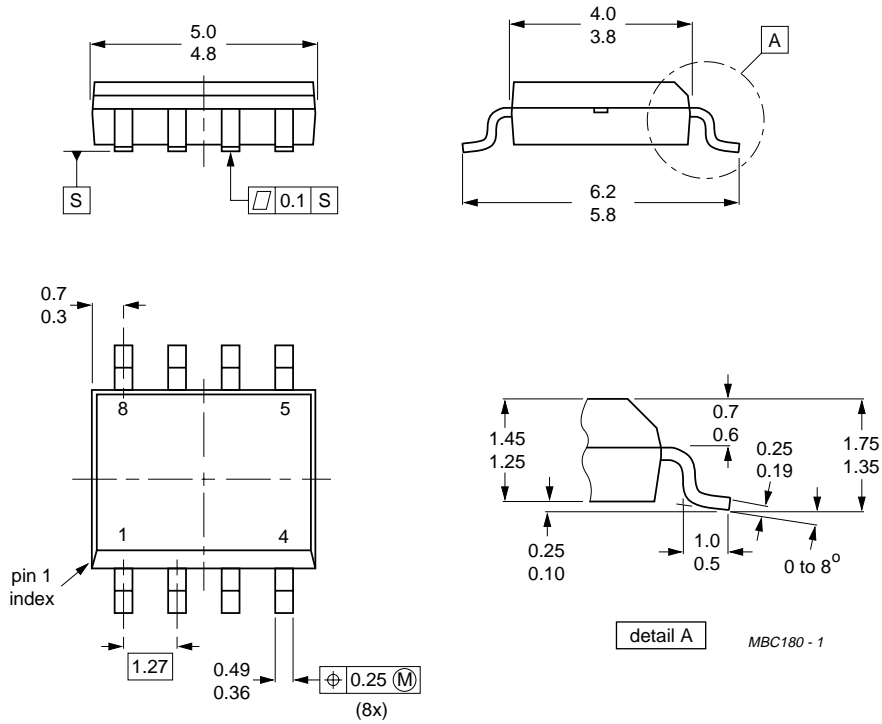

Dimensions in mm.

Fig.8 Plastic small outline package; 8 leads; body width 3.9 mm (SO8; SOT96-1).

## Supply circuit with power-down for telephone set peripherals

TEA1081

### SOLDERING

#### Plastic dual in-line packages

BY DIP OR WAVE

The maximum permissible temperature of the solder is 260 °C; this temperature must not be in contact with the joint for more than 5 s. The total contact time of successive solder waves must not exceed 5 s.

The device may be mounted up to the seating plane, but the temperature of the plastic body must not exceed the specified storage maximum. If the printed-circuit board has been pre-heated, forced cooling may be necessary immediately after soldering to keep the temperature within the permissible limit.

#### REPAIRING SOLDERED JOINTS

Apply a low-voltage soldering iron below the seating plane (or not more than 2 mm above it). If its temperature is below 300 °C, it must not be in contact for more than 10 s; if between 300 and 400 °C, for not more than 5 s.

#### Plastic small-outline packages

BY WAVE

During placement and before soldering, the component must be fixed with a droplet of adhesive. After curing the adhesive, the component can be soldered. The adhesive can be applied by screen printing, pin transfer or syringe dispensing.

Maximum permissible solder temperature is 260 °C, and maximum duration of package immersion in solder bath is 10 s, if allowed to cool to less than 150 °C within 6 s. Typical dwell time is 4 s at 250 °C.

A modified wave soldering technique is recommended using two solder waves (dual-wave), in which a turbulent wave with high upward pressure is followed by a smooth laminar wave. Using a mildly-activated flux eliminates the need for removal of corrosive residues in most applications.

#### BY SOLDER PASTE REFLOW

Reflow soldering requires the solder paste (a suspension of fine solder particles, flux and binding agent) to be applied to the substrate by screen printing, stencilling or pressure-syringe dispensing before device placement.

Several techniques exist for reflowing; for example, thermal conduction by heated belt, infrared, and vapour-phase reflow. Dwell times vary between 50 and 300 s according to method. Typical reflow temperatures range from 215 to 250 °C.

Preheating is necessary to dry the paste and evaporate the binding agent. Preheating duration: 45 min at 45 °C.

#### REPAIRING SOLDERED JOINTS (BY HAND-HELD SOLDERING IRON OR PULSE-HEATED SOLDER TOOL)

Fix the component by first soldering two, diagonally opposite, end pins. Apply the heating tool to the flat part of the pin only. Contact time must be limited to 10 s at up to 300 °C. When using proper tools, all other pins can be soldered in one operation within 2 to 5 s at between 270 and 320 °C. (Pulse-heated soldering is not recommended for SO packages.)

For pulse-heated solder tool (resistance) soldering of VSO packages, solder is applied to the substrate by dipping or by an extra thick tin/lead plating before package placement.

---

# Supply circuit with power-down for telephone set peripherals

---

TEA1081

**DEFINITIONS**

<b>Data sheet status</b>	
Objective specification	This data sheet contains target or goal specifications for product development.
Preliminary specification	This data sheet contains preliminary data; supplementary data may be published later.
Product specification	This data sheet contains final product specifications.
<b>Limiting values</b>	
Limiting values given are in accordance with the Absolute Maximum Rating System (IEC 134). Stress above one or more of the limiting values may cause permanent damage to the device. These are stress ratings only and operation of the device at these or at any other conditions above those given in the Characteristics sections of the specification is not implied. Exposure to limiting values for extended periods may affect device reliability.	
<b>Application information</b>	
Where application information is given, it is advisory and does not form part of the specification.	

**LIFE SUPPORT APPLICATIONS**

These products are not designed for use in life support appliances, devices, or systems where malfunction of these products can reasonably be expected to result in personal injury. Philips customers using or selling these products for use in such applications do so at their own risk and agree to fully indemnify Philips for any damages resulting from such improper use or sale.

Supply circuit with power-down for  
telephone set peripherals

TEA1081

---

**NOTES**

---

Supply circuit with power-down for  
telephone set peripherals

---

TEA1081

**NOTES**

Supply circuit with power-down for  
telephone set peripherals

TEA1081

---

**NOTES**

## Philips Semiconductors – a worldwide company

**Argentina:** IEROD, Av. Juramento 1992 - 14.b, (1428)  
BUENOS AIRES, Tel. (541)786 7633, Fax. (541)786 9367

**Australia:** 34 Waterloo Road, NORTH RYDE, NSW 2113,  
Tel. (02)805 4455, Fax. (02)805 4466

**Austria:** Triester Str. 64, A-1101 WIEN, P.O. Box 213,  
Tel. (01)60 101-1236, Fax. (01)60 101-1211

**Belgium:** Postbus 90050, 5600 PB EINDHOVEN, The Netherlands,  
Tel. (31)40 783 749, Fax. (31)40 788 399

**Brazil:** Rua do Rocio 220 - 5<sup>th</sup> floor, Suite 51,  
CEP: 04552-903-SÃO PAULO-SP, Brazil.  
P.O. Box 7383 (01064-970).

Tel. (011)821-2333, Fax. (011)829-1849

**Canada:** PHILIPS SEMICONDUCTORS/COMPONENTS:  
Tel. (800) 234-7381, Fax. (708) 296-8556

**Chile:** Av. Santa Maria 0760, SANTIAGO,  
Tel. (02)773 816, Fax. (02)777 6730

**Colombia:** IPRELENZO LTDA, Carrera 21 No. 56-17,  
77621 BOGOTA, Tel. (571)249 7624/(571)217 4609,  
Fax. (571)217 4549

**Denmark:** Prags Boulevard 80, PB 1919, DK-2300 COPENHAGEN S,  
Tel. (032)88 2636, Fax. (031)57 1949

**Finland:** Sinikalliontie 3, FIN-02630 ESPOO,  
Tel. (9)0-50261, Fax. (9)0-520971

**France:** 4 Rue du Port-aux-Vins, BP317,  
92156 SURESNES Cedex,  
Tel. (01)4099 6161, Fax. (01)4099 6427

**Germany:** P.O. Box 10 63 23, 20043 HAMBURG,  
Tel. (040)3296-0, Fax. (040)3296 213.

**Greece:** No. 15, 25th March Street, GR 17778 TAVROS,  
Tel. (01)4894 339/4894 911, Fax. (01)4814 240

**Hong Kong:** PHILIPS HONG KONG Ltd., 6/F Philips Ind. Bldg.,  
24-28 Kung Yip St., KWAI CHUNG, N.T.,  
Tel. (852)424 5121, Fax. (852)428 6729

**India:** Philips INDIA Ltd, Shivsagar Estate, A Block,  
Dr. Annie Besant Rd. Worli, Bombay 400 018  
Tel. (022)4938 541, Fax. (022)4938 722

**Indonesia:** Philips House, Jalan H.R. Rasuna Said Kav. 3-4,  
P.O. Box 4252, JAKARTA 12950,  
Tel. (021)5201 122, Fax. (021)5205 189

**Ireland:** Newstead, Clonskeagh, DUBLIN 14,  
Tel. (01)640 000, Fax. (01)640 200

**Italy:** PHILIPS SEMICONDUCTORS S.r.l.,  
Piazza IV Novembre 3, 20124 MILANO,  
Tel. (0039)2 6752 2531, Fax. (0039)2 6752 2557

**Japan:** Philips Bldg 13-37, Kohnan2-chome, Minato-ku, TOKYO 108,  
Tel. (03)3740 5028, Fax. (03)3740 0580

**Korea:** (Republic of) Philips House, 260-199 Itaewon-dong,  
Yongsan-ku, SEOUL, Tel. (02)794-5011, Fax. (02)798-8022

**Malaysia:** No. 76 Jalan Universiti, 46200 PETALING JAYA,  
SELANGOR, Tel. (03)750 5214, Fax. (03)757 4880

**Mexico:** 5900 Gateway East, Suite 200, EL PASO, TX 79905,  
Tel. 9-5(800)234-7381, Fax. (708)296-8556

**Netherlands:** Postbus 90050, 5600 PB EINDHOVEN, Bldg. VB  
Tel. (040)783749, Fax. (040)788399

**New Zealand:** 2 Wagener Place, C.P.O. Box 1041, AUCKLAND,  
Tel. (09)849-4160, Fax. (09)849-7811

**Norway:** Box 1, Manglerud 0612, OSLO,  
Tel. (022)74 8000, Fax. (022)74 8341

**Pakistan:** Philips Electrical Industries of Pakistan Ltd.,  
Exchange Bldg. ST-2/A, Block 9, KDA Scheme 5, Clifton,  
KARACHI 75600, Tel. (021)587 4641-49,  
Fax. (021)577035/5874546.

**Philippines:** PHILIPS SEMICONDUCTORS PHILIPPINES Inc,  
106 Valero St. Salcedo Village, P.O. Box 2108 MCC, MAKATI,  
Metro MANILA, Tel. (02)810 0161, Fax. (02)817 3474

**Portugal:** PHILIPS PORTUGUESA, S.A.,  
Rua dr. António Loureiro Borges 5, Arquiparque - Miraflores,  
Apartado 300, 2795 LINDA-A-VELHA,  
Tel. (01)14163160/4163333, Fax. (01)14163174/4163366.

**Singapore:** Lorong 1, Toa Payoh, SINGAPORE 1231,  
Tel. (65)350 2000, Fax. (65)251 6500

**South Africa:** S.A. PHILIPS Pty Ltd.,  
195-215 Main Road Martindale, 2092 JOHANNESBURG,  
P.O. Box 7430 Johannesburg 2000,  
Tel. (011)470-5911, Fax. (011)470-5494.

**Spain:** Balmes 22, 08007 BARCELONA,  
Tel. (03)301 6312, Fax. (03)301 42 43

**Sweden:** Kottbygatan 7, Akalla. S-164 85 STOCKHOLM,  
Tel. (0)8-632 2000, Fax. (0)8-632 2745

**Switzerland:** Allmendstrasse 140, CH-8027 ZÜRICH,  
Tel. (01)488 2211, Fax. (01)481 77 30

**Taiwan:** PHILIPS TAIWAN Ltd., 23-30F, 66, Chung Hsiao West  
Road, Sec. 1, Taipei, Taiwan ROC, P.O. Box 22978,  
TAIPEI 100, Tel. (02)388 7666, Fax. (02)382 4382.

**Thailand:** PHILIPS ELECTRONICS (THAILAND) Ltd.,  
209/2 Sanpavuth-Bangna Road Prakanong,  
Bangkok 10260, THAILAND,  
Tel. (662)398-0141, Fax. (662)398-3319.

**Turkey:** Talatpasa Cad. No. 5, 80640 GÜLTEPE/ISTANBUL,  
Tel. (0212)279 2770, Fax. (0212)269 3094

**United Kingdom:** Philips Semiconductors LTD.,  
276 Bath road, Hayes, MIDDLESEX UB3 5BX,  
Tel. (081)73050000, Fax. (081)7548421

**United States:** 811 East Arques Avenue, SUNNYVALE,  
CA 94088-3409, Tel. (800)234-7381, Fax. (708)296-8556

**Uruguay:** Coronel Mora 433, MONTEVIDEO,  
Tel. (02)70-4044, Fax. (02)92 0601

**For all other countries apply to:** Philips Semiconductors,  
International Marketing and Sales, Building BE-p,  
P.O. Box 218, 5600 MD, EINDHOVEN, The Netherlands,  
Telex 35000 phtcnl, Fax. +31-40-724825

SCD34

© Philips Electronics N.V. 1994

All rights are reserved. Reproduction in whole or in part is prohibited without the prior written consent of the copyright owner.

The information presented in this document does not form part of any quotation or contract, is believed to be accurate and reliable and may be changed without notice. No liability will be accepted by the publisher for any consequence of its use. Publication thereof does not convey nor imply any license under patent- or other industrial or intellectual property rights.

Printed in The Netherlands

413061/1500/02/pp16

Date of release: September 1994

Document order number:

9397 739 40011

# Philips Semiconductors



# PHILIPS