

DATA SHEET

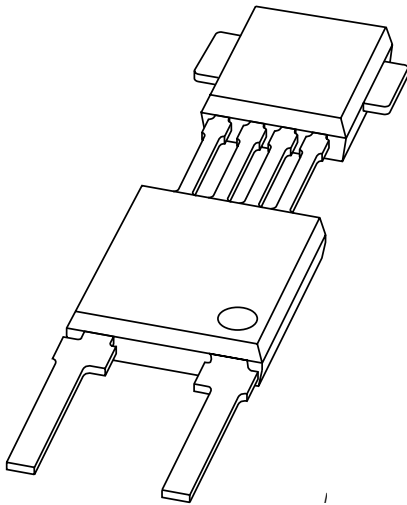

KMI15/2

Integrated rotational speed sensor

Product specification
Supersedes data of 1996 Dec 05
File under Discrete Semiconductors, SC17

1998 Mar 25

Integrated rotational speed sensor

KMI15/2

FEATURES

- Digital current output signal
- Zero speed capability
- Wide air gap
- Wide temperature range
- Insensitive to vibration
- EMC resistant.

DESCRIPTION

The KMI15/2 sensor detects (rotational) speed and reference mark detection of magnetized targets⁽¹⁾. The sensor consists of a magnetoresistive sensor element, a signal conditioning integrated circuit in bipolar technology and a magnetized ferrite magnet. The frequency of the digital current output signal is proportional to the rotational speed of a gear wheel.

CAUTION
Do not press two or more products together against their magnetic forces.

(1) The sensor contains a customized integrated circuit. Usage in hydraulic brake systems and in systems with active brake control is forbidden.

PINNING

PIN	DESCRIPTION
1	V _{CC}
2	V ₋

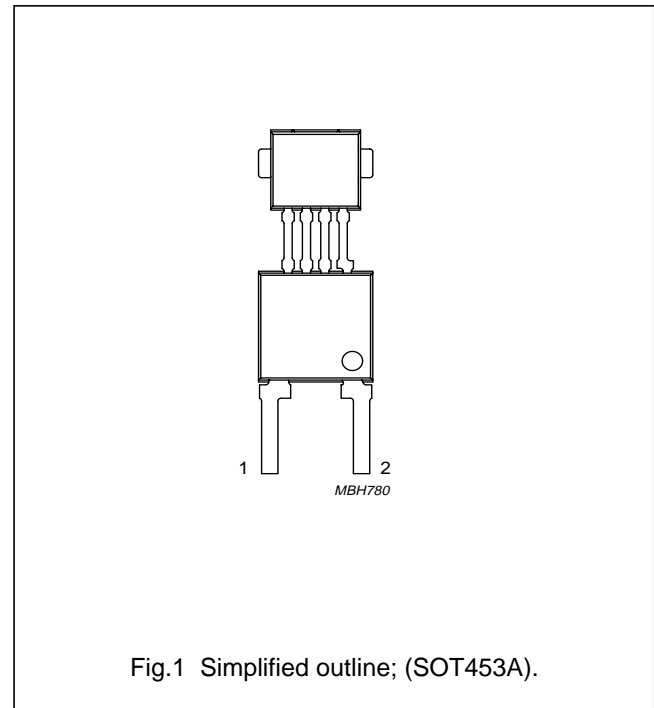

Fig.1 Simplified outline; (SOT453A).

QUICK REFERENCE DATA

SYMBOL	PARAMETER	MIN.	TYP.	MAX.	UNIT
V _{CC}	DC supply voltage	0.5	12	16	V
I _{CC (low)}	current output signal low	–	7	–	mA
I _{CC (high)}	current output signal high	–	14	–	mA
f _t	operating frequency	0	–	25000	Hz
T _{amb}	ambient operating temperature	–40	–	+85	°C

Integrated rotational speed sensor

KMI15/2

LIMITING VALUES

In accordance with Absolute Maximum Rating System (IEC 134).

SYMBOL	PARAMETER	CONDITIONS	MIN.	MAX.	UNIT
V_{CC}	DC supply voltage	$T_{amb} = -40$ to $+85$ °C; $R_L = 115$ Ω	0.5	16	V
T_{stg}	storage temperature		-40	+150	°C
T_{amb}	operating ambient temperature		-40	+85	°C
T_{sld}	soldering temperature	$t \leq 10$ s	-	260	°C
	output short-circuit duration to GND		continuous		

CHARACTERISTICS $T_{amb} = 25$ °C; $V_{CC} = 12$ V; $f_t = 2$ kHz; test circuit: see Fig.7; $R_L = 115$ Ω .

SYMBOL	PARAMETER	CONDITIONS	MIN.	TYP.	MAX.	UNIT
$I_{CC (low)}$	current output signal low	see Fig.6	5.6	7.0	8.4	mA
$I_{CC (high)}$	current output signal high	see Fig.6	11.2	14.0	16.8	mA
t_r	output signal rise time	$C_L = 100$ pF; 10 to 90% value	-	0.5	-	μ s
t_f	output signal fall time	$C_L = 100$ pF; 10 to 90% value	-	0.7	-	μ s
t_d	switching delay time	between stimulation pulse (generated by a coil) and output signal	-	1	-	μ s
f_t	operating frequency	for both rotation directions	0	-	25000	Hz
H_{sLH}	magnetic switching field strength		0.05	0.3	0.8	kA/m
H_{sHL}	magnetic switching field strength		0.05	0.3	0.8	kA/m
H_s	magnetic switching hysteresis		0.15	-	1.6	kA/m

Integrated rotational speed sensor

KMI15/2

FUNCTIONAL DESCRIPTION

The KMI15/2 sensor is sensitive to magnetic fields. The functional principle is shown in Fig.3. The field lines of a magnetized target are shown in Fig.3 as a straight target (it could also be circular e.g. for rotational speed measurement). If a sensor KMI15/2 is moved as shown in this field, either of the magnetic field components H_{sHL} or H_{sLH} is dominant, and forces the sensor to switch to either the high current (14 mA) or to the low current (7 mA). Oscillation of the sensor output signal is avoided by the implementation of a hysteresis into the signal conditioning electronic.

The MR sensor is stabilized by a permanent magnet applying a continuous magnetic field of ≥ 6 kA/m to the sensor. If the magnetic field given by the magnetized target errors like frequency doubling might occur. The magnetoresistive sensor element signal is amplified, temperature compensated and forwarded to a Schmitt-trigger in the conditioning integrated circuit (Figs 4 and 5). The digital output signal levels (Fig.6) are independent of the magnetic field condition. A (2-wire) output current enables safe transfer of the sensor signal to the detecting circuit (Fig.7). The integrated circuit housing is separated from the sensor element housing to optimize the sensor behaviour at high temperatures.

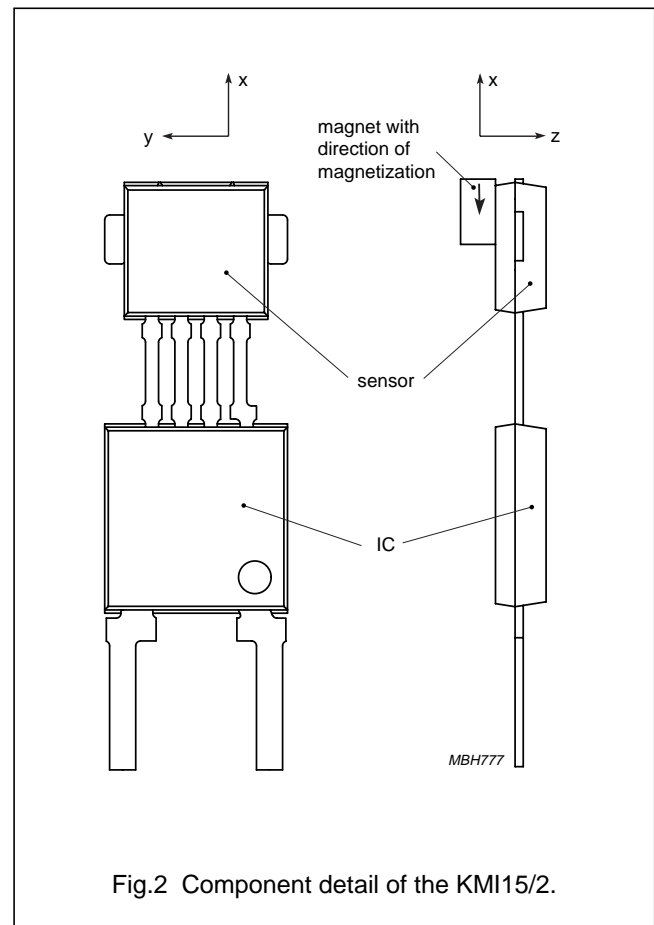

Fig.2 Component detail of the KMI15/2.

Integrated rotational speed sensor

KMI15/2

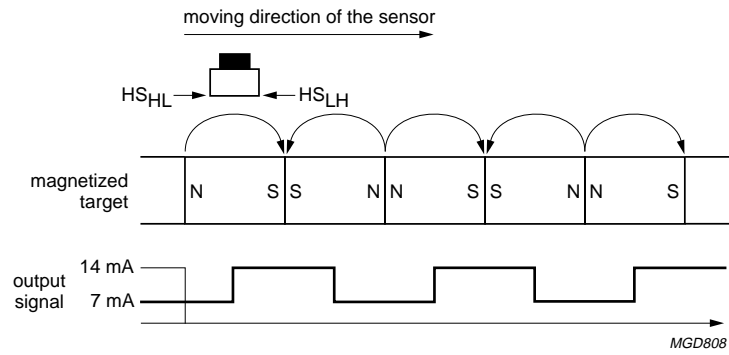

Fig.3 Functional principle of KMI15/2.

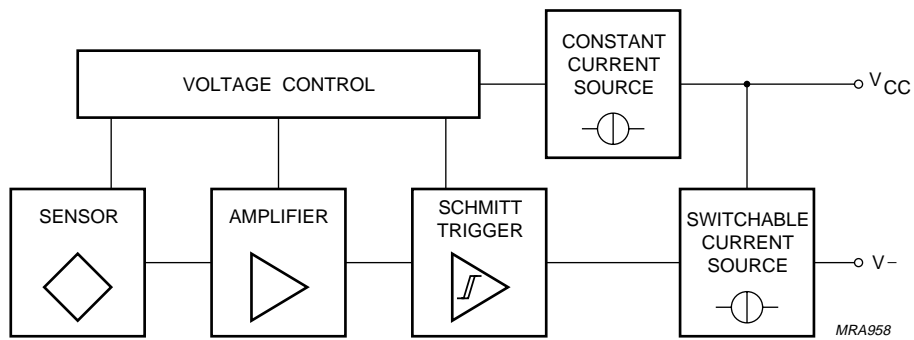
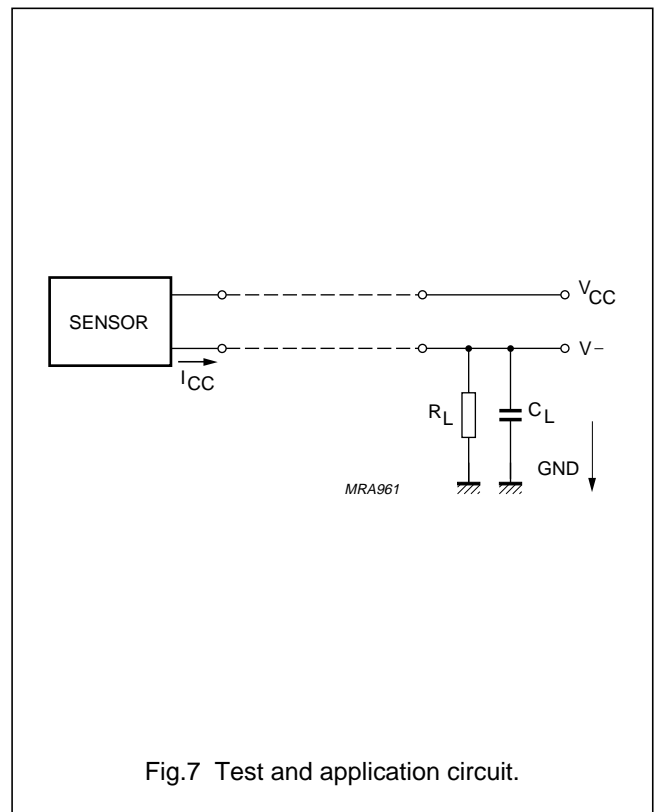
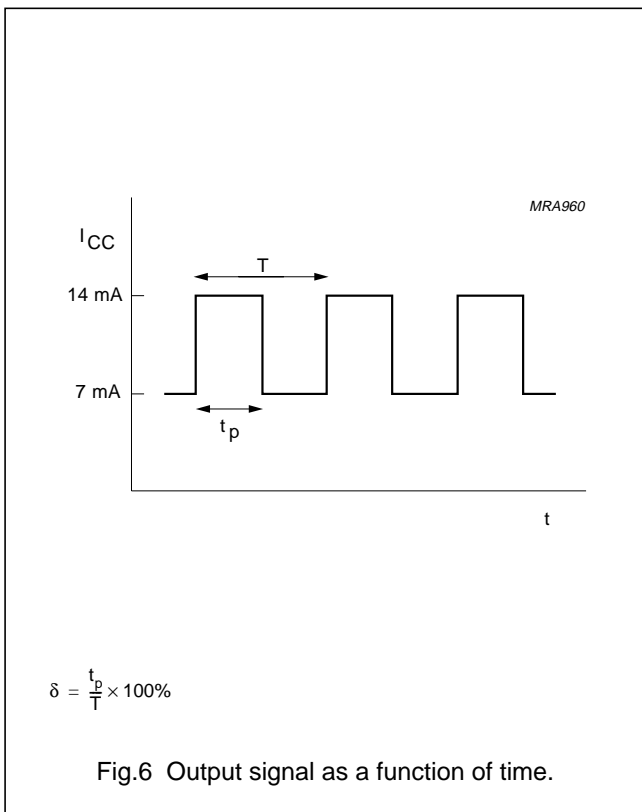
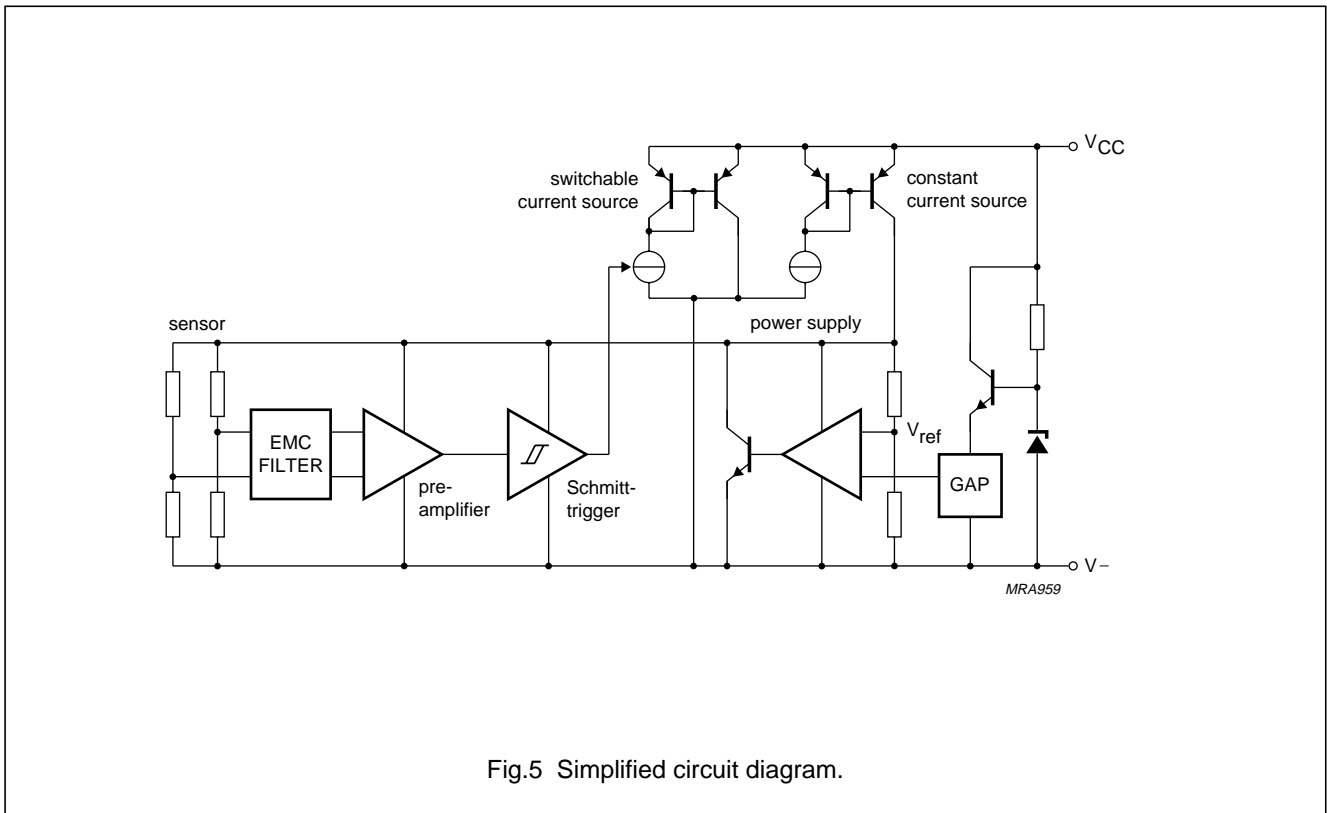

Fig.4 Block diagram.

Integrated rotational speed sensor

KMI15/2



Integrated rotational speed sensor

KMI15/2

PACKAGE OUTLINE

Plastic single-ended combined package; magnetoresistive sensor element; bipolar IC; magnetized ferrite magnet (3.8 x 2.0 x 0.8 mm); 2 in-line leads

SOT453A

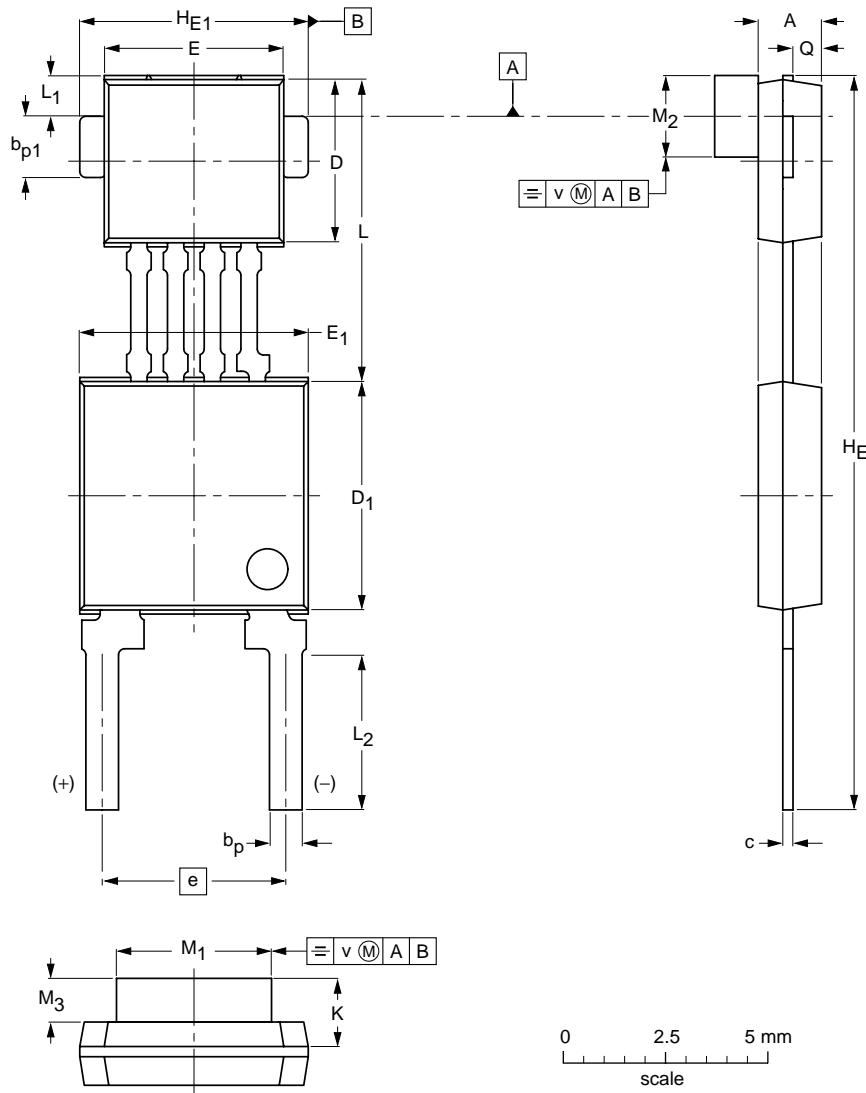

DIMENSIONS (mm are the original dimensions)

UNIT	A	b _p	b _{p1}	c	D ⁽¹⁾	D ₁ ⁽¹⁾	E ⁽¹⁾	E ₁ ⁽¹⁾	e	H _E	H _{E1}	K _{max.}	L	L ₁	L ₂	M ₁	M ₂	M ₃	Q	v
mm	1.7 1.4	0.8 0.7	1.5 1.4	0.3 0.24	4.1 3.9	5.7 5.5	4.5 4.3	5.7 5.5	4.6 4.4	18.2 17.8	5.6 5.5	1.67	7.55 7.25	1.2 0.9	3.9 3.5	3.9 3.7	2.1 1.9	0.9 0.75	0.75 0.65	0.25

Note

1. Plastic or metal protrusions of 0.15 mm maximum per side are not included.

OUTLINE VERSION	REFERENCES				EUROPEAN PROJECTION	ISSUE DATE
	IEC	JEDEC	EIAJ			
SOT453A						96-11-12 97-02-28

Integrated rotational speed sensor
KMI15/2

DEFINITIONS

Data sheet status	
Objective specification	This data sheet contains target or goal specifications for product development.
Preliminary specification	This data sheet contains preliminary data; supplementary data may be published later.
Product specification	This data sheet contains final product specifications.
Limiting values	
Limiting values given are in accordance with the Absolute Maximum Rating System (IEC 134). Stress above one or more of the limiting values may cause permanent damage to the device. These are stress ratings only and operation of the device at these or at any other conditions above those given in the Characteristics sections of the specification is not implied. Exposure to limiting values for extended periods may affect device reliability.	
Application information	
Where application information is given, it is advisory and does not form part of the specification.	

LIFE SUPPORT APPLICATIONS

These products are not designed for use in life support appliances, devices, or systems where malfunction of these products can reasonably be expected to result in personal injury. Philips customers using or selling these products for use in such applications do so at their own risk and agree to fully indemnify Philips for any damages resulting from such improper use or sale.

Integrated rotational speed sensor

KMI15/2

NOTES

Integrated rotational speed sensor

KMI15/2

NOTES

Integrated rotational speed sensor

KMI15/2

NOTES

Philips Semiconductors – a worldwide company

Argentina: see South America

Australia: 34 Waterloo Road, NORTH RYDE, NSW 2113,
Tel. +61 2 9805 4455, Fax. +61 2 9805 4466

Austria: Computerstr. 6, A-1101 WIEN, P.O. Box 213,
Tel. +43 1 60 101, Fax. +43 1 60 101 1210

Belarus: Hotel Minsk Business Center, Bld. 3, r. 1211, Volodarski Str. 6,
220050 MINSK, Tel. +375 172 200 733, Fax. +375 172 200 773

Belgium: see The Netherlands

Brazil: see South America

Bulgaria: Philips Bulgaria Ltd., Energoproject, 15th floor,
51 James Bourchier Blvd., 1407 SOFIA,
Tel. +359 2 689 211, Fax. +359 2 689 102

Canada: PHILIPS SEMICONDUCTORS/COMPONENTS,
Tel. +1 800 234 7381

China/Hong Kong: 501 Hong Kong Industrial Technology Centre,
72 Tat Chee Avenue, Kowloon Tong, HONG KONG,
Tel. +852 2319 7888, Fax. +852 2319 7700

Colombia: see South America

Czech Republic: see Austria

Denmark: Prags Boulevard 80, PB 1919, DK-2300 COPENHAGEN S,
Tel. +45 32 88 2636, Fax. +45 31 57 1949

Finland: Sinikalliontie 3, FIN-02630 ESPOO,
Tel. +358 9 615800, Fax. +358 9 61580/xxx

France: 4 Rue du Port-aux-Vins, BP317, 92156 SURESNES Cedex,
Tel. +33 1 40 99 6161, Fax. +33 1 40 99 6427

Germany: Hammerbrookstraße 69, D-20097 HAMBURG,
Tel. +49 40 23 53 60, Fax. +49 40 23 536 300

Greece: No. 15, 25th March Street, GR 17778 TAVROS/ATHENS,
Tel. +30 1 4894 339/239, Fax. +30 1 4814 240

Hungary: see Austria

India: Philips INDIA Ltd, Shivsagar Estate, A Block, Dr. Annie Besant Rd.
Worli, MUMBAI 400 018, Tel. +91 22 4938 541, Fax. +91 22 4938 722

Indonesia: see Singapore

Ireland: Newstead, Clonskeagh, DUBLIN 14,
Tel. +353 1 7640 000, Fax. +353 1 7640 200

Israel: RAPAC Electronics, 7 Kehilat Saloniki St, TEL AVIV 61180,
Tel. +972 3 645 0444, Fax. +972 3 649 1007

Italy: PHILIPS SEMICONDUCTORS, Piazza IV Novembre 3,
20124 MILANO, Tel. +39 2 6752 2531, Fax. +39 2 6752 2557

Japan: Philips Bldg 13-37, Kohnan 2-chome, Minato-ku, TOKYO 108,
Tel. +81 3 3740 5130, Fax. +81 3 3740 5077

Korea: Philips House, 260-199 Itaewon-dong, Yongsan-ku, SEOUL,
Tel. +82 2 709 1412, Fax. +82 2 709 1415

Malaysia: No. 76 Jalan Universiti, 46200 PETALING JAYA, SELANGOR,
Tel. +60 3 750 5214, Fax. +60 3 757 4880

Mexico: 5900 Gateway East, Suite 200, EL PASO, TEXAS 79905,
Tel. +9-5 800 234 7381

Middle East: see Italy

Netherlands: Postbus 90050, 5600 PB EINDHOVEN, Bldg. VB,
Tel. +31 40 27 82785, Fax. +31 40 27 88399

New Zealand: 2 Wagener Place, C.P.O. Box 1041, AUCKLAND,
Tel. +64 9 849 4160, Fax. +64 9 849 7811

Norway: Box 1, Manglerud 0612, OSLO,
Tel. +47 22 74 8000, Fax. +47 22 74 8341

Philippines: Philips Semiconductors Philippines Inc.,
106 Valero St. Salcedo Village, P.O. Box 2108 MCC, MAKATI,
Metro MANILA, Tel. +63 2 816 6380, Fax. +63 2 817 3474

Poland: Ul. Lukiska 10, PL 04-123 WARSZAWA,
Tel. +48 22 612 2831, Fax. +48 22 612 2327

Portugal: see Spain

Romania: see Italy

Russia: Philips Russia, Ul. Usatcheva 35A, 119048 MOSCOW,
Tel. +7 095 247 9145, Fax. +7 095 247 9144

Singapore: Lorong 1, Toa Payoh, SINGAPORE 1231,
Tel. +65 350 2538, Fax. +65 251 6500

Slovakia: see Austria

Slovenia: see Italy

South Africa: S.A. PHILIPS Pty Ltd., 195-215 Main Road Martindale,
2092 JOHANNESBURG, P.O. Box 7430 Johannesburg 2000,
Tel. +27 11 470 5911, Fax. +27 11 470 5494

South America: Rua do Rocio 220, 5th floor, Suite 51,
04552-903 São Paulo, SÃO PAULO - SP, Brazil,
Tel. +55 11 821 2333, Fax. +55 11 829 1849

Spain: Balmes 22, 08007 BARCELONA,
Tel. +34 3 301 6312, Fax. +34 3 301 4107

Sweden: Kottbygatan 7, Akalla, S-16485 STOCKHOLM,
Tel. +46 8 632 2000, Fax. +46 8 632 2745

Switzerland: Allmendstrasse 140, CH-8027 ZÜRICH,
Tel. +41 1 488 2686, Fax. +41 1 481 7730

Taiwan: PHILIPS TAIWAN Ltd., 23-30F, 66,
Chung Hsiao West Road, Sec. 1, P.O. Box 22978,
TAIPEI 100, Tel. +886 2 382 4443, Fax. +886 2 382 4444

Thailand: PHILIPS ELECTRONICS (THAILAND) Ltd.,
209/2 Sanpavuth-Bangna Road Prakanong, BANGKOK 10260,
Tel. +66 2 745 4090, Fax. +66 2 398 0793

Turkey: Talatpasa Cad. No. 5, 80640 GÜLTEPE/ISTANBUL,
Tel. +90 212 279 2770, Fax. +90 212 282 6707

Ukraine: PHILIPS UKRAINE, 4 Patrice Lumumba str., Building B, Floor 7,
252042 KIEV, Tel. +380 44 264 2776, Fax. +380 44 268 0461

United Kingdom: Philips Semiconductors Ltd., 276 Bath Road, Hayes,
MIDDLESEX UB3 5BX, Tel. +44 181 730 5000, Fax. +44 181 754 8421

United States: 811 East Arques Avenue, SUNNYVALE, CA 94088-3409,
Tel. +1 800 234 7381

Uruguay: see South America

Vietnam: see Singapore

Yugoslavia: PHILIPS, Trg N. Pasica 5/v, 11000 BEOGRAD,
Tel. +381 11 625 344, Fax. +381 11 635 777

For all other countries apply to: Philips Semiconductors, Marketing & Sales Communications,
Building BE-p, P.O. Box 218, 5600 MD EINDHOVEN, The Netherlands, Fax. +31 40 27 24825

Internet: <http://www.semiconductors.philips.com>

© Philips Electronics N.V. 1996

SCA52

All rights are reserved. Reproduction in whole or in part is prohibited without the prior written consent of the copyright owner.

The information presented in this document does not form part of any quotation or contract, is believed to be accurate and reliable and may be changed without notice. No liability will be accepted by the publisher for any consequence of its use. Publication thereof does not convey nor imply any license under patent- or other industrial or intellectual property rights.

Printed in The Netherlands

115106/1200/02/pp12

Date of release: 1998 Mar 25

Document order number: 9397 750 03603

Let's make things better.

Philips
Semiconductors



PHILIPS