

# UCB1510

AC97 digital modem codec

Rev. 01 — 4 February 2000

Preliminary specification

## 1. Description

---

The UCB1510 is a single chip, integrated mixed signal telecom codec that can directly be connected to a DAA and supports high speed modem protocols. The general purpose I/O pins provide programmable inputs and/or outputs to the system.

The UCB1510 has a serial AClink interface intended to communicate to the system controller. Both the codec input data and codec output data and the control register data are multiplexed on this interface.

## 2. Features

---

- Sigma delta telecom codec with programmable sample rate, including digitally controlled input voltage level, mute, loop back and clip detection functions. The telecom codec can be directly connected to a Data Access Arrangement (DAA) and includes a built in sidetone suppression circuit
- AClink (rev 2.1) interface with secondary codec support
- 3.3 V supply voltage and built in power saving modes make the UCB1510 optimal for portable and battery powered applications
- 5 V tolerant interface for motherboard/PC add on
- Maximum operating current 25 mA
- 8 general purpose IO pins for line interface control
- Interrupt detection driven wake up sequence for ring detect
- Low cost 12.288 MHz crystal

## 3. Applications

---

- Standalone modems
- Integrated modems
- Audio/Modem Riser (AMR) Cards
- Mobile Daughter Cards (MDC)



**PHILIPS**

## 4. Ordering information

Table 1: Ordering information

| Type number | Package |  | Version  |
|-------------|---------|--|----------|
|             | Name    | Description  |          |
| UCB1510DB   | SSOP28  | plastic shrink small outline package, 28 leads, body width 5.3mm | SOT341-1 |

## 5. Block diagram

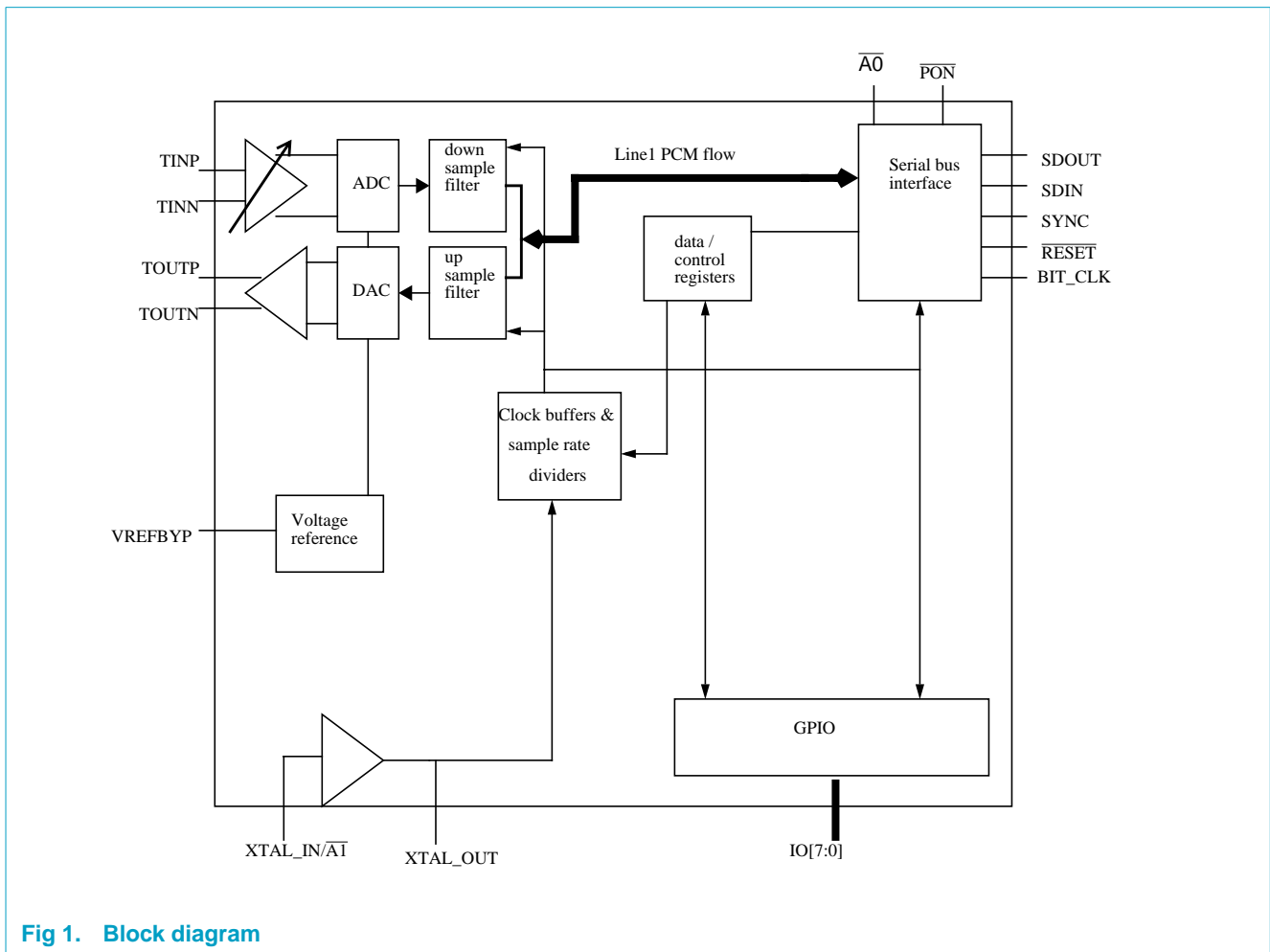
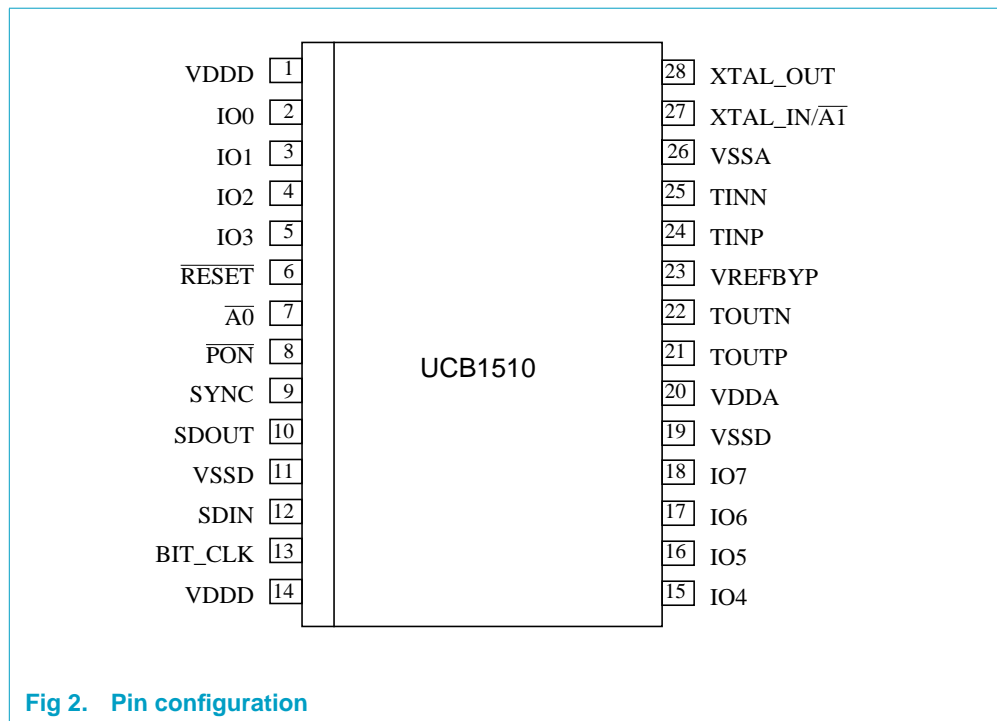

Fig 1. Block diagram

## 6. Pinning information

### 6.1 Pinning



### 6.2 Pin description

Table 2: Pin description

| Symbol           | Pin | Reset state <sup>[1]</sup> | Type <sup>[2]</sup> | Description  |
|------------------|-----|----------------------------|---------------------|--|
| V <sub>DDD</sub> | 1   | -                          | S                   | digital supply   |
| IO0              | 2   | input                      | I/O <sub>C</sub>    | general purpose I/O pins                                 |
| IO1              | 3   | input                      | I/O <sub>C</sub>    | general purpose I/O pins                                 |
| IO2              | 4   | input                      | I/O <sub>C</sub>    | general purpose I/O pins                                 |
| IO3              | 5   | input                      | I/O <sub>C</sub>    | general purpose I/O pins                                 |
| RESET            | 6   | -                          | I <sub>C</sub>      | asynchronous reset input                                 |
| A0               | 7   | -                          | I <sub>C</sub>      | address select (for secondary codec) - inverted polarity |
| PON              | 8   | -                          | I <sub>C</sub>      | asynchronous cold reset                                  |
| SYNC             | 9   | -                          | I/O <sub>C</sub>    | AClink synchronization input                             |
| SDOUT            | 10  | -                          | I <sub>C</sub>      | AClink data input  |
| V <sub>SSD</sub> | 11  | -                          | S                   | digital ground   |
| SDIN             | 12  | 0 <sup>[4]</sup>           | O <sub>C</sub>      | AClink data output                                       |
| BIT_CLK          | 13  | - <sup>[3]</sup>           | I/O <sub>C</sub>    | AClink serial interface clock                            |
| V <sub>DDD</sub> | 14  | -                          | S                   | digital supply   |
| IO4              | 15  | input                      | I/O <sub>C</sub>    | general purpose I/O pins                                 |

Table 2: Pin description...continued

| Symbol                 | Pin | Reset state <sup>[1]</sup> | Type <sup>[2]</sup>            | Description  |
|------------------------|-----|----------------------------|--------------------------------|--|
| IO5                    | 16  | input                      | I/O <sub>C</sub>               | general purpose I/O pins   |
| IO6                    | 17  | input                      | I/O <sub>C</sub>               | general purpose I/O pins   |
| IO7                    | 18  | input                      | I/O <sub>C</sub>               | general purpose I/O pins   |
| V <sub>SSD</sub>       | 19  | -                          | S                              | digital ground   |
| V <sub>DDA</sub>       | 20  | -                          | S                              | analog supply  |
| TOUTP                  | 21  | hi Z                       | O <sub>A</sub>                 | positive telecom codec output                                    |
| TOUTN                  | 22  | hi Z                       | O <sub>A</sub>                 | negative telecom codec output                                    |
| VREFBYP                | 23  | hi Z                       | I/O <sub>A</sub>               | external reference voltage bypass                                |
| TINP                   | 24  | -                          | I <sub>A</sub>                 | positive telecom codec input                                     |
| TINN                   | 25  | -                          | I <sub>A</sub>                 | negative telecom codec input                                     |
| V <sub>SSA</sub>       | 26  | -                          | S                              | analog ground  |
| XTAL_IN/A <sub>1</sub> | 27  | - <sup>[3]</sup>           | I <sub>A</sub> /I <sub>C</sub> | Xtal oscillator/master clock input or inverted secondary address |
| XTAL_OUT               | 28  | - <sup>[3]</sup>           | O <sub>A</sub>                 | Xtal oscillator output   |

[1] After cold or warm reset, the AClink interface is active with MLNK bit reset.

[2] I/O<sub>C</sub> = CMOS bidirectional; I<sub>D</sub> = digital input; S = supply; O<sub>A</sub> = analog output; I<sub>C</sub> = CMOS input; I<sub>A</sub> = analog input; I/O<sub>A</sub> = analog bidirectional; O<sub>C</sub> = CMOS output.

[3] BIT\_CLK is an input for AClink secondary codec, an output for primary codec. When BIT\_CLK is an output, the XTAL oscillator is active.

[4] SDIN is driving a 0 until a valid SYNC framing signal is received after cold reset.

## 7. Functional description

The functional description of the devices is described in [Section 8](#) through [Section 15](#).

## 8. Telecom codec

The telecom codec contains an input channel, built up from a 64 times oversampling sigma delta analog to digital converter (ADC) with digital decimation filters, programmable gain and attenuation and built-in sidetone suppression circuit.

The output path consists of a digital up sample filter, a 64 time oversampling 4 bit digital to analog converter (DAC) circuit with integrated filter followed by a differential output driver, capable of directly driving a 600 Ω isolation transformer. The output path includes a mute function. The telecom codec also incorporates loop back modes, in which codec output path and the input path are connected in series. The loop back tap and entry points are identified as circled letters in [Figure 3](#), loop back modes are described in the AClink register definition.

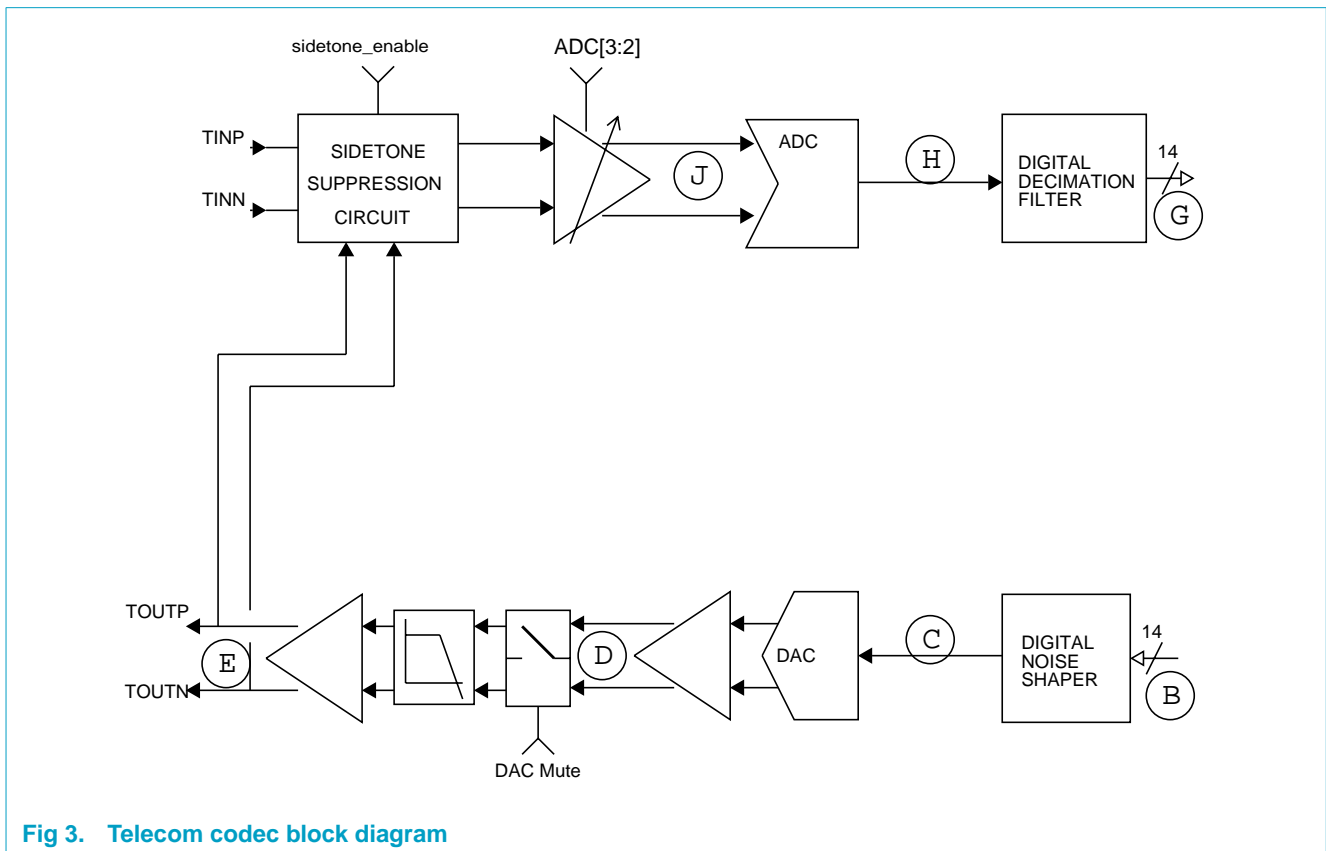

Fig 3. Telecom codec block diagram

The telecom sample rate ( $f_{st}$ ) is derived from the AC master clock and is programmable using the sample rate registers. Not all AC97 specified sample rates are supported, refer to [Table 3 "Sampling frequencies"](#) for details.

PCM data is transferred in the slot 5 of the AClink.

Table 3: Sampling frequencies

| Sampling frequency (Hz) | Register 0x40 value | Support | AC '97 requirements |
|-------------------------|---------------------|---------|---------------------|
| 7200                    | 0x1C20              | no      | recommended         |
| 8000                    | 0x1F40              | yes     | required            |
| 8228.57 (57600/7)       | 0x2024              | no      | recommended         |
| 8400                    | 0x20D0              | no      | recommended         |
| 9000                    | 0x2328              | no      | recommended         |
| 9600                    | 0x2580              | yes     | required            |
| 10285.71 (72000/7)      | 0x282D              | no      | recommended         |
| 12000                   | 0x2EE0              | yes     | recommended         |
| 13714.29 (96000/7)      | 0x3592              | yes     | required            |
| 16000                   | 0x3E80              | yes     | required            |
| 19200                   | 0x4B00              | yes     | recommended         |
| 24000                   | 0x5DC0              | yes     | recommended         |
| 48000                   | 0xBB80              | no      | recommended         |

Any programmed value above 24 kHz will lead to a 24 kHz sampling rate.

Changing the sampling rate while the codec is active may lead to unpredictable results in the ADC and DAC chains and should be avoided.

The output section of the telecom codec is designed to interface with a 600  $\Omega$  line through an isolation transformer. The built in mute function is activated by the **DAC Mute** bit in register 0x46. The output driver remains active in the mute mode, however no output signal is produced.

## 8.1 Digital filters

These filters are tailored for high speed modem performance.

A voice band filter can be activated to reduce the noise in the lower frequencies.

Table 4: Filter characteristics

| Parameter                          | Condition              | Value             |
|------------------------------------|------------------------|-------------------|
| Group delay                        |                        | 25 samples        |
| Pass band ripple                   |                        | $\pm 0.1$ dB      |
| Out of band rejection              | $>0.55$ fs             | -50 dB            |
| Pass band                          | (no voice band filter) | 0.0016 to 0.45 fs |
| Transition band                    |                        | 0.45 to 0.55 fs   |
| Voice band filter rejection band   | 0-0.0018 fs            | 30 dB             |
| Voice band filter cutoff frequency |                        | 0.05 fs           |

8.2 Analog interface

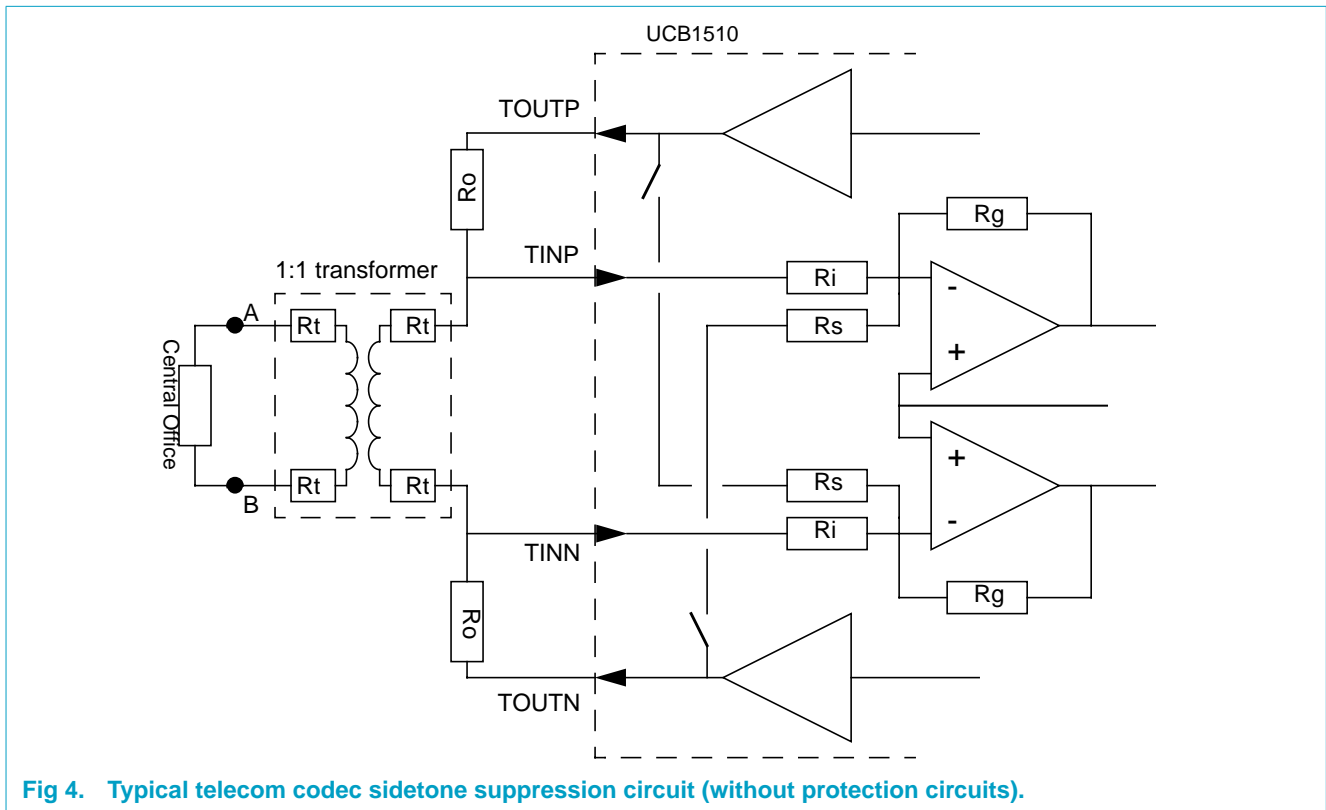

Fig 4. Typical telecom codec sidetone suppression circuit (without protection circuits).

An important built-in feature of the telecom codec is the sidetone suppression circuit. The sidetone suppression circuit is activated when **sidetone\_enable** of register 0x5A is set. The sidetone suppression circuit subtracts part of the telecom output signal from the telecom input signal. As a result the available dynamic range of the input path can be more effectively utilized. If the sidetone suppression circuit is disabled, the telecom input dynamic range can be largely occupied by the telecom output signal.

The built-in side tone suppression circuit, shown in Figure 4, has a fixed subtraction ratio, set by the resistors  $R_s$  and  $R_i$ , which equals  $600/456$ . This ratio is calculated from the following relations.

The impedance seen by the telephone line equals:

$$Z_{line} = 2 \times \left( R_t + R_t + \frac{R_o \times R_i}{R_o + R_i} \right), \text{ differential, in which } R_t \text{ represents winding resistance}$$

of the transformer, divided by 2. Assuming  $R_i \gg R_o$ , then

$$R_{line} = R_t + R_t + R_o = 600/2 = 300\Omega \text{ single ended.}$$

A typical transformer has  $156 \Omega$  winding impedance, thus  $R_o$  should be  $144 \Omega$ . The ratio of the telecom input and output voltage is, therefore:

$$V_{i(tel)} = V_{o(tel)} \times \frac{156 + 300}{156 + 300 + 144} = V_{o(tel)} \times \frac{456}{600}$$

Proper sidetone suppression thus requires  $R_s/R_i$  to be  $V_i/V_o$ .

## 9. On-chip reference circuit

The UCB1510 contains an on chip reference voltage source, which generates the bias currents and the virtual analog ground. Alternatively the UCB1510 can be driven from an external reference voltage source.

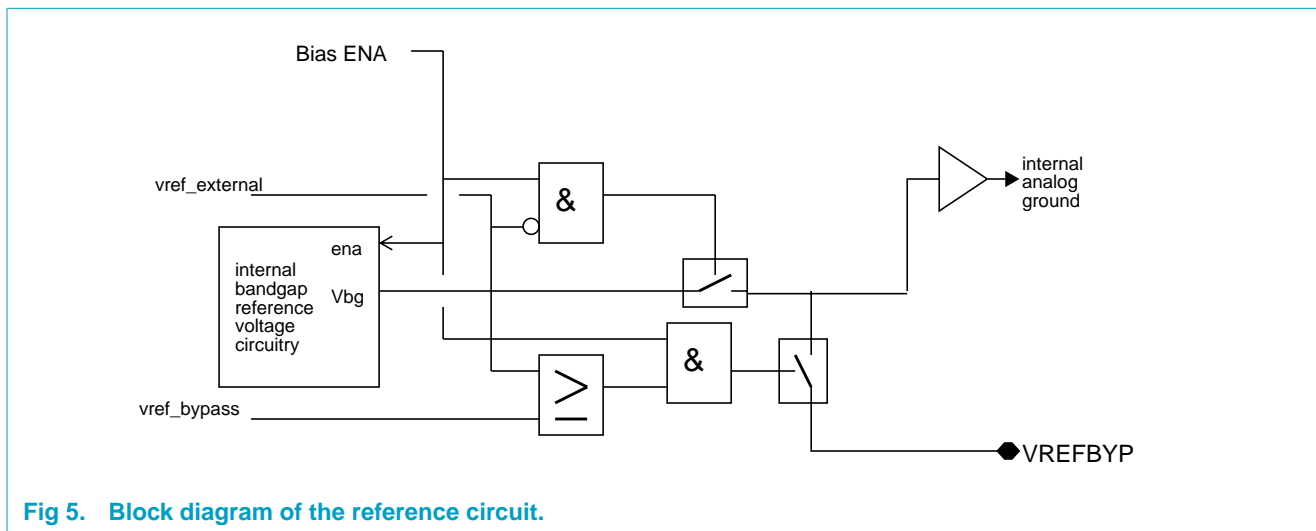

Fig 5. Block diagram of the reference circuit.

Two bits in the control register 0x5A determine the mode of operation of this reference voltage circuit. **vref\_bypass** connects the internal reference voltage to the VREFBYP pin, while **vref\_external** disables the internal reference voltage and switches the UCB1510 into the external voltage reference mode.

If the internal reference voltage is connected to the VREFBYP pin, an external capacitor could be connected to filter this reference voltage. When choosing a capacitor, the internal impedance (around 50 k $\Omega$ ) should be taken into account.

If **vref\_external** is set, an external voltage reference connected to the VREFBYP pin is used as the voltage reference by UCB1510.

## 10. Power supply strategy

Since all the control logic of the UCB1510 is powered by the  $V_{DDD}$ , power should always be present on this pin for interrupts to be possible.  $V_{DDA}$  needs not be present all the time although it is recommended to use the control bits to turn OFF the analog sections.



## 11. Register definition

### 11.1 Supported registers

Table 5: Supported registers

| Register      | Name                                       |
|---------------|--|
| 0x00 to 0x3A  | All audio registers are ignored            |
| 0x3C          | Extended Modem ID                          |
| 0x3E          | Extended Modem Status and Control          |
| 0x40          | Line1 DAC/ADC Rate                         |
| 0x42 and 0x44 | Reserved for future use                    |
| 0x46          | Line1 DAC/ADC Level                        |
| 0x48 and 0x4A | Reserved for future use                    |
| 0x4C          | GPIO Pin Configuration                     |
| 0x4E          | GPIO Pin Polarity                          |
| 0x50          | GPIO Pin Sticky                            |
| 0x52          | GPIO Pin Wake-up Mask                      |
| 0x54          | GPIO Pin Status                            |
| 0x56          | Miscellaneous Modem AFE Status and Control |
| 0x58          | Ignored                                    |
| 0x5A          | Codec control                              |
| 0x5C          | Mode control                               |
| 0x5E          | Test control                               |
| 0x5E to 0x7A  | Ignored                                    |
| 0x7C          | Vendor ID1                                 |
| 0x7E          | Vendor ID2                                 |

### 11.2 Register detail

Shaded areas indicate read only data.

#### 11.2.1 Extended Modem ID

Table 6: Extended Modem ID Register

Register address: 0x3C; default: N/A

| Bit    | D15 | D14 | D13 | D12 | D11 | D10 | D9 | D8   |
|--------|-----|-----|-----|-----|-----|-----|----|------|
| Symbol | ID1 | ID0 |     |     |     |     |    |      |
| Bit    | D7  | D6  | D5  | D4  | D3  | D2  | D1 | D0   |
| Symbol |     |     |     | 0   | 0   | 0   | 0  | LIN1 |

Table 7: Description of Extended Modem ID bits

| Bit    | Symbol  | Function/Value  |
|--------|---------|---|
| D15:14 | ID[1:0] | {A1,A0} where A0 is the inverse polarity of the $\overline{A0}$ pin. A1 is the inverse polarity of <b>XTAL_IN</b> pin if A0 is HIGH ( $\overline{A0}$ pin is LOW), otherwise A1 is 0. |
| D0     | LIN1    | Line 1 support indicator = 1 (i.e., Line 1 is supported).   |

[1] Writing this register will cause a register reset: all modem registers will then take their default values.

### 11.2.2 Extended Modem Status and Control

**Table 8: Extended Modem Status and Control Register**

Register address: 0x3E; default: 0xFFxx

| Bit    | D15  | D14  | D13  | D12  | D11  | D10  | D9   | D8   |
|--------|------|------|------|------|------|------|------|------|
| Symbol | PRH  | PRG  | PRF  | PRE  | PRD  | PRC  | PRB  | PRA  |
| Bit    | D7   | D6   | D5   | D4   | D3   | D2   | D1   | D0   |
| Symbol | HDAC | HADC | DAC2 | ADC2 | DAC1 | ADC1 | MREF | GPIO |

**Table 9: Description of Extended Modem status and Control bits**

| Bit | Symbol | Function/Value  |
|-----|--------|---|
| D15 | PRH    | Reserved, should be 1   |
| D14 | PRG    | Reserved, should be 1   |
| D13 | PRF    | Reserved, should be 1   |
| D12 | PRE    | Reserved, should be 1   |
| D11 | PRD    | 1 -> Line1 DAC OFF  |
| D10 | PRC    | 1 -> Line1 ADC OFF  |
| D9  | PRB    | 1 -> Line1 V <sub>REF</sub> OFF   |
| D8  | PRA    | 1 -> GPIO OFF   |
| D7  | HDAC   | 0 (not supported)   |
| D6  | HADC   | 0 (not supported)   |
| D5  | DAC2   | 0 (not supported)   |
| D4  | ADC2   | 0 (not supported)   |
| D3  | DAC1   | 1 indicates Line1 DAC ready (means that the Line1 DAC and the V <sub>REF</sub> are enabled and ready) |
| D2  | ADC1   | 1 indicates Line1 ADC ready (means that the Line1 ADC and the V <sub>REF</sub> are enabled and ready) |
| D1  | MREF   | 1 indicates Line1 V <sub>REF</sub> up to nominal level.   |
| D0  | GPIO   | 1 indicates GPIO ready.   |

### 11.2.3 Line 1 Sample Rate

**Table 10: Line 1 Sample Rate Register**

Register address: 0x40; default: 0x1F40

| Bit    | D15  | D14  | D13  | D12  | D11  | D10  | D9  | D8  |
|--------|------|------|------|------|------|------|-----|-----|
| Symbol | SR15 | SR14 | SR13 | SR12 | SR11 | SR10 | SR9 | SR8 |
| Bit    | D7   | D6   | D5   | D4   | D3   | D2   | D1  | D0  |
| Symbol | SR7  | SR6  | SR5  | SR4  | SR3  | SR2  | SR1 | SR0 |

Refer to [Table 3 "Sampling frequencies"](#) for supported sample rates.

### 11.2.4 Line 1 DAC/ADC Level

**Table 11: Line 1 DAC/ADC Level Register**

Register address: 0x46; default: 0x8080

| Bit    | D15      | D14 | D13 | D12 | D11  | D10  | D9   | D8   |
|--------|----------|-----|-----|-----|------|------|------|------|
| Symbol | DAC mute |     |     |     |      |      |      |      |
| Bit    | D7       | D6  | D5  | D4  | D3   | D2   | D1   | D0   |
| Symbol | ADC mute |     |     |     | ADC3 | ADC2 | ADC1 | ADC0 |

**Table 12: Description of Line1 DAC/ADC Level bits**

| Bit   | Symbol   | Function/Value  |
|-------|----------|---|
| D15   | DAC mute | DAC section is active, but no signal will be sent.      |
| D7    | ADC mute | ADC section is active, but no signal will be sent.      |
| D3-D2 | ADC[3:2] | ADC Gain (0 -> 0 dB, 1 -> 6 dB, 2 -> 12 dB, 3 -> 18 dB) |
| D1-D0 | ADC[1:0] | These bits are ignored.                                 |

### 11.2.5 GPIO Pin Configuration

**Table 13: GPIO Pin Configuration Register**

Register address: 0x4C; default: 0x00FF

| Bit    | D15 | D14 | D13 | D12 | D11 | D10 | D9  | D8  |
|--------|-----|-----|-----|-----|-----|-----|-----|-----|
| Symbol |     |     |     |     |     |     |     |     |
| Bit    | D7  | D6  | D5  | D4  | D3  | D2  | D1  | D0  |
| Symbol | GC7 | GC6 | GC5 | GC4 | GC3 | GC2 | GC1 | GC0 |

The GPIO Pin Configuration register specifies whether a GPIO pin is configured for input (1) or for output (0).

### 11.2.6 GPIO Pin Polarity

**Table 14: GPIO Pin Polarity Register**

Register address: 0x4E; default: 0xFFFF

| Bit    | D15 | D14 | D13 | D12 | D11 | D10 | D9  | D8  |
|--------|-----|-----|-----|-----|-----|-----|-----|-----|
| Symbol |     |     |     |     |     |     |     |     |
| Bit    | D7  | D6  | D5  | D4  | D3  | D2  | D1  | D0  |
| Symbol | GP7 | GP6 | GP5 | GP4 | GP3 | GP2 | GP1 | GP0 |

The GPIO Pin Polarity register defines GPIO Input Polarity (0 = Low, 1 = High) when a GPIO pin is configured as an input.

### 11.2.7 GPIO Pin Sticky

**Table 15: GPIO Pin Sticky Register**

Register address: 0x50; default: 0x0000

| Bit    | D15 | D14 | D13 | D12 | D11 | D10 | D9  | D8  |
|--------|-----|-----|-----|-----|-----|-----|-----|-----|
| Symbol |     |     |     |     |     |     |     |     |
| Bit    | D7  | D6  | D5  | D4  | D3  | D2  | D1  | D0  |
| Symbol | GS7 | GS6 | GS5 | GS4 | GS3 | GS2 | GS1 | GS0 |

The GPIO Pin Sticky register defines GPIO Input Type (0 = Non-Sticky, 1 = Sticky) when a GPIO pin is configured as input. Sticky is defined as Edge sensitive, Non-Sticky as Level-sensitive.

GPIO inputs configured as Sticky are cleared by writing a 0 to the corresponding bit of the GPIO Pin Status register 0x54, and by reset.

**Remark:** Changing GPIO control registers while a GPIO is sticky may cause unwanted interrupts and should be done carefully.

### 11.2.8 GPIO Wake-up Mask

**Table 16: GPIO Wake-up Mask Register**

Register address: 0x52; default: 0x0000

| Bit    | D15 | D14 | D13 | D12 | D11 | D10 | D9  | D8  |
|--------|-----|-----|-----|-----|-----|-----|-----|-----|
| Symbol |     |     |     |     |     |     |     |     |
| Bit    | D7  | D6  | D5  | D4  | D3  | D2  | D1  | D0  |
| Symbol | GW7 | GW6 | GW5 | GW4 | GW3 | GW2 | GW1 | GW0 |

The GPIO Pin Wake-up Mask register provides a mask for determining if an input GPIO change will generate a wake-up or GPIO\_INT (0 = No, 1 = Yes).

When the AC-link is powered down, a wake-up event will trigger the assertion of SDIN. When the AC-link is powered up, a wake-up event will appear as GPIO\_INT = 1 on bit 0 of input slot 12.

### 11.2.9 GPIO Pin Status

**Table 17: GPIO Pin Status Register**

Register address: 0x54; default: N/A

| Bit    | D15 | D14 | D13 | D12 | D11 | D10 | D9  | D8  |
|--------|-----|-----|-----|-----|-----|-----|-----|-----|
| Symbol |     |     |     |     |     |     |     |     |
| Bit    | D7  | D6  | D5  | D4  | D3  | D2  | D1  | D0  |
| Symbol | GI7 | GI6 | GI5 | GI4 | GI3 | GI2 | GI1 | GI0 |

The GPIO Status register reflects the state of all GPIO pins (inputs and outputs) on slot 12.

When the GPIO is an output pin, the value set on slot #12 is transmitted directly to the pin. When the GPIO pin is a non-sticky input, the status of the pin is accessible in read mode. When the GPIO is a sticky Input, a transition, either from high to low (polarity = 0) or from low-to-high (polarity = 1), will assert the corresponding GI bit to 1. The GI bit will remain asserted until it is cleared by a write of 0.

## 11.2.10 Miscellaneous Modem AFE Status and Control

Table 18: Miscellaneous Modem AFE Status and Control Register

Register address: 0x56; default: 0x0000

| Bit    | D15 | D14                     | D13  | D12 | D11 | D10                     | D9   | D8   |
|--------|-----|-------------------------|------|-----|-----|-------------------------|------|------|
| Symbol |     |                         | MLNK |     |     | reserved, should be 0x0 |      |      |
| Bit    | D7  | D6                      | D5   | D4  | D3  | D2                      | D1   | D0   |
| Symbol |     | reserved, should be 0x0 |      |     |     | L1B2                    | L1B1 | L1B0 |

Table 19: Description of Miscellaneous Modem AFE Status and Control bits

| Bit    | Symbol   | Function/Value  |
|--------|----------|---|
| D13    | MLNK     | 1 -> AClink goes to sleep.                                  |
| D[2:0] | L1B[2:0] | Line1 loop back modes (refer to <a href="#">Table 20</a> ). |

Table 20: Loop back modes

See [Figure 3](#).

| Mode | Description  |
|------|--|
| 0    | Disabled   |
| 1    | ADC loop back (incoming analog signal is amplified, digitized, down-sampled, LOOPED, up-sampled, converted to analog, amplified/filtered) (G) to (B) loop.             |
| 2    | Local analog loop back (digital signal is up-sampled, converted to analog, amplified/filtered, LOOPED, amplified, digitized, down-sampled, sent back) (E) to (J) loop. |
| 3    | DAC loop back (digital signal is up-sampled, converted to analog, LOOPED digitized, down-sampled, sent back) (E) to (J) loop. Same as mode 2.                          |
| 4    | Remote analog loop back (incoming analog signal is amplified, LOOPED, amplified/filtered, sent back) (J) to (D) loop.  |
| 7    | Digital loop back: signal is captured from the AC-link and sent back as is. Slot request for slot#5 is controlled according to the programmed sampling rate.           |

### 11.2.11 Vendor Specific Codec Control

**Table 21: codec\_control Register**

Register address: 0x5A; default: 0x0400

| Bit    | D15 | D14 | D13 | D12 | D11 | D10 | D9 | D8 |
|--------|-----|-----|-----|-----|-----|-----|----|----|
| Symbol |     |     |     | AC  |     | ME  | VE | VB |
| Bit    | D7  | D6  | D5  | D4  | D3  | D2  | D1 | D0 |
| Symbol | 0   | 0   | 0   | SE  | 0   | 0   | 0  | VF |

**Table 22: codec\_control bits**

| Bit               | Symbol | Function/Value   |
|-------------------|--------|--|
| D12               | AC     | adc_clip, in read mode, this bit indicates clipping in the line1 ADC. This indicator is sticky and should be cleared by writing it with a 0. |
| D10               | ME     | reserved, should be 1  |
| D9                | VE     | vref_external, overwrites VB   |
| D8                | VB     | vref_bypass  |
| D[7:5],<br>D[3:1] | 0      | Bits marked '0' are reserved for future use and should be programmed with 0.   |
| D4                | SE     | sidetone_enable  |
| D0                | VF     | voice_filter:1->enable voice band digital filter.  |

### 11.2.12 Vendor Specific Mode Control

**Table 23: mode\_control Register**

Register address: 0x5C; default: 0x0000

| Bit    | D15 | D14 | D13 | D12 | D11 | D10 | D9            | D8        |
|--------|-----|-----|-----|-----|-----|-----|---------------|-----------|
| Symbol |     |     |     |     |     |     | reserved: 0x0 |           |
| Bit    | D7  | D6  | D5  | D4  | D3  | D2  | D1            | D0        |
| Symbol |     | 0   | 0   | 0   |     |     | 0             | BITSTREAM |

[1] Bits marked 0 are reserved for future use and should be programmed with 0.

**Table 24: mode\_control bits**

| Bit | Symbol    | Function/Value   |
|-----|-----------|--|
| D0  | BITSTREAM | line1 ADC bitstream data is sent directly to IO4. The associated clock is sent to IO6. |

### 11.2.13 Vendor specific Test Control

**Table 25: Test\_control Register**

Register address: 0x5E; default: N/A

| Bit    | D15 | D14 | D13 | D12 | D11 | D10 | D9 | D8 |
|--------|-----|-----|-----|-----|-----|-----|----|----|
| Symbol |     |     |     |     |     |     |    |    |
| Bit    | D7  | D6  | D5  | D4  | D3  | D2  | D1 | D0 |
| Symbol |     |     |     |     |     |     |    |    |

This register cannot be reset. It has no effect until the IC is put in vendor test mode (see [Table 29 "Mode selection with AC pins"](#)).

### 11.2.14 Vendor ID1

**Table 26: Vendor ID1 Register**

Register address: 0x7C; default: 0x5053

| Bit    | D15 | D14 | D13 | D12 | D11 | D10 | D9 | D8 |
|--------|-----|-----|-----|-----|-----|-----|----|----|
| Symbol | 0   | 1   | 0   | 1   | 0   | 0   | 0  | 0  |
| Bit    | D7  | D6  | D5  | D4  | D3  | D2  | D1 | D0 |
| Symbol | 0   | 1   | 0   | 1   | 0   | 0   | 1  | 1  |

### 11.2.15 Vendor ID2

**Table 27: Vendor ID2 Register**

Register address: 0x7E; default: 0x4301

| Bit    | D15 | D14 | D13 | D12 | D11 | D10 | D9 | D8 |
|--------|-----|-----|-----|-----|-----|-----|----|----|
| Symbol | 0   | 1   | 0   | 0   | 0   | 0   | 1  | 1  |
| Bit    | D7  | D6  | D5  | D4  | D3  | D2  | D1 | D0 |
| Symbol | 0   | 0   | 0   | 0   | 0   | 0   | 0  | 1  |

## 11.3 Register reset modes

### 11.3.1 Warm reset

When a warm reset is activated, MLNK is set to 0 but the other registers retain their values. If the codec is primary, the BIT\_CLK is started and stabilized after 200 ms.

### 11.3.2 Cold reset

When a cold reset is activated, MLNK is set to 0 and all registers are programmed to their default values. If the codec is primary, the BIT\_CLK is started and stabilized after 200 ms.

### 11.3.3 Register reset

A register reset causes all registers to return to their default values. Initiated by a write to register 0x3C.

## 12. AC97 interface

### 12.1 Control register data transfer

The AClink frames is made of 13 slots. Slot0 is a 16-bit long tag slot, the remaining 12 slots are 20-bit long data transfer.

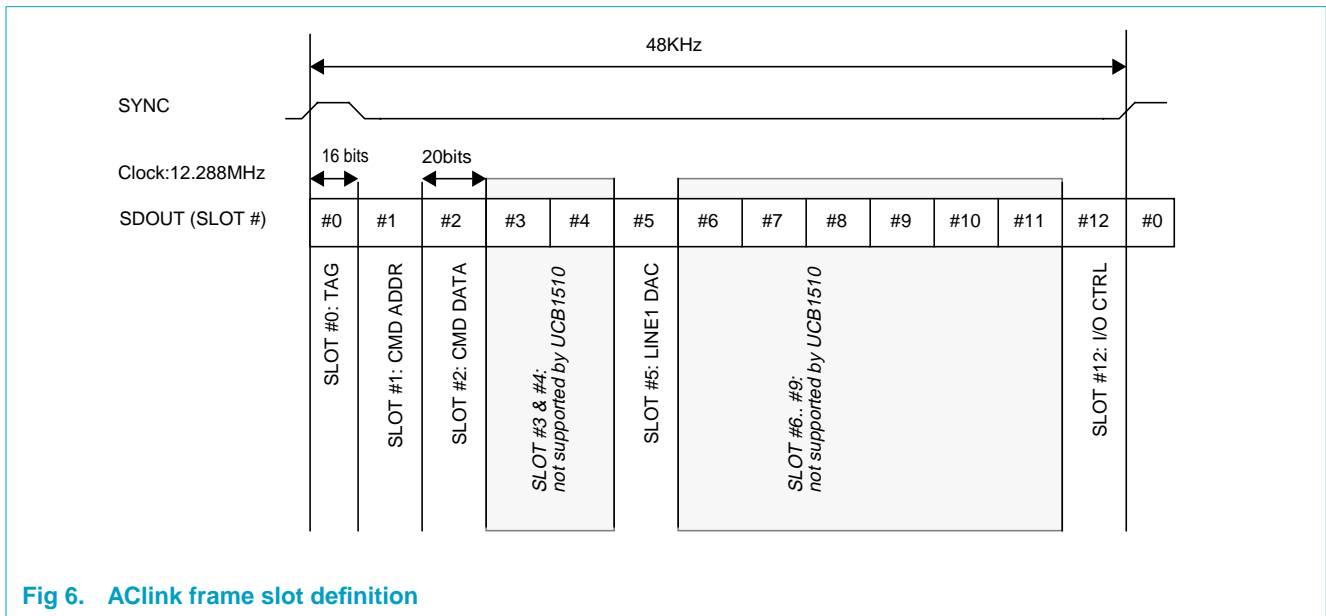

Fig 6. AClink frame slot definition

Register update is done at the end of slot 2. The new register value is effective thereafter.

Slot #0 and slot #3 to #12 are shared by all codecs (primary and secondary). Multiple codecs using the same slot cannot be used at the same time. Slot #1 and slot #2 are used for register transfer and are codec specific. Addressing is defined in the Tag slot #0: The UCB1510 will send a 1 as Tag slot bit 15 whenever the AClink is active (MLNK is 0).



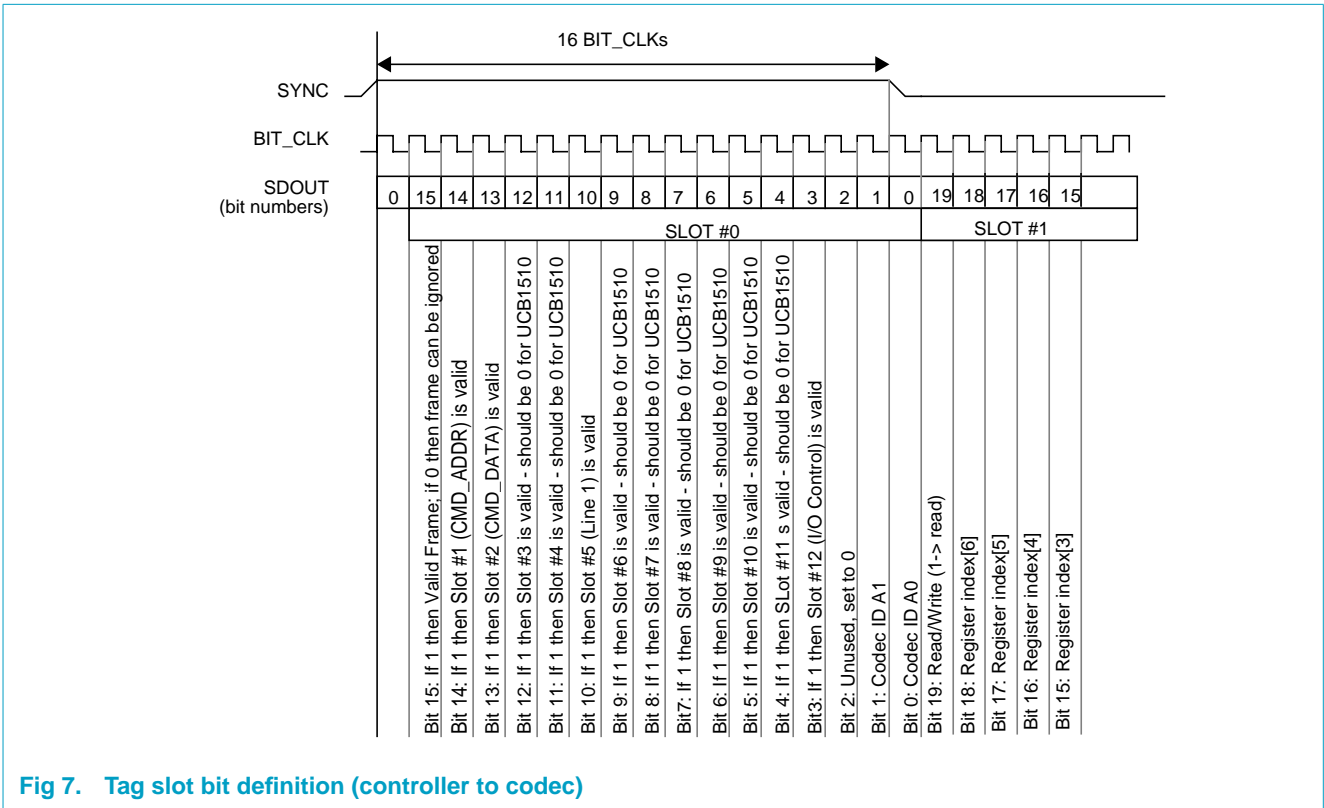

Fig 7. Tag slot bit definition (controller to codec)

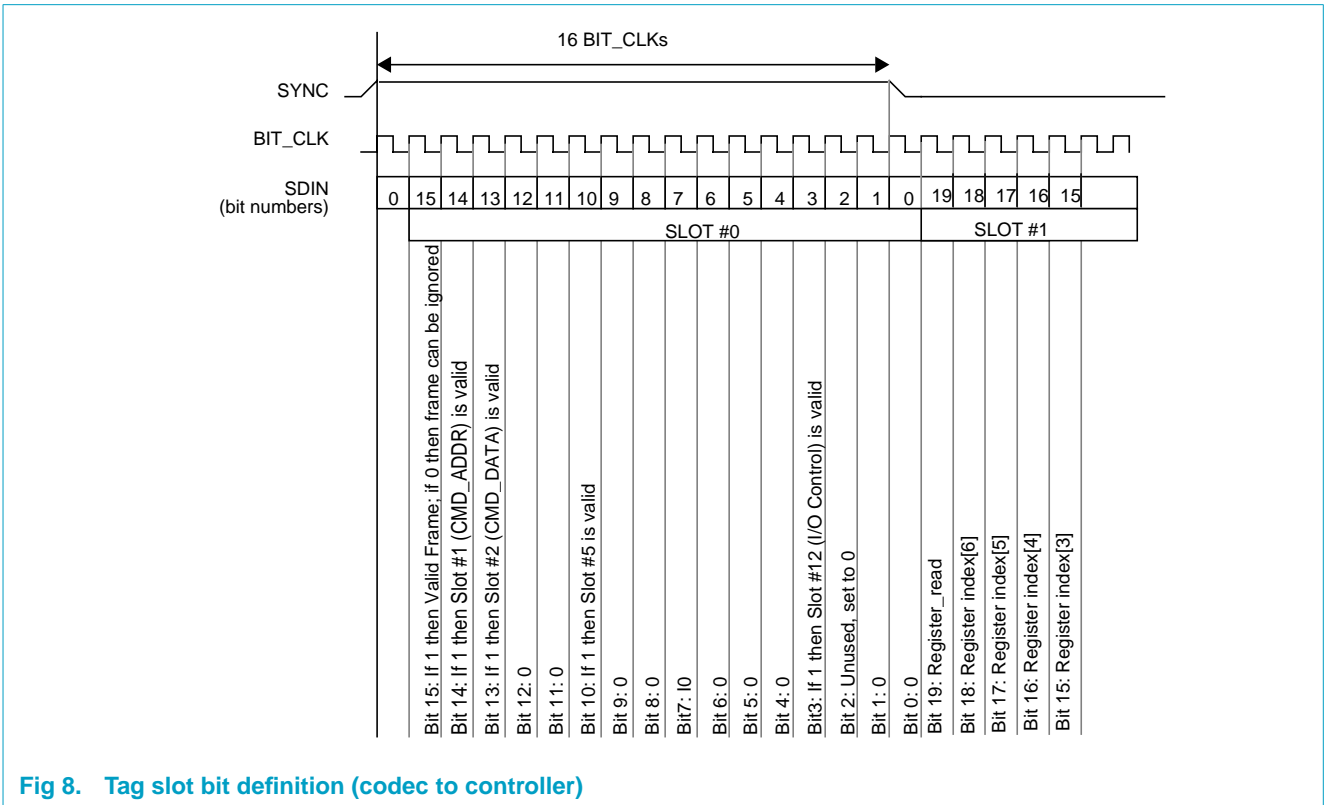

Fig 8. Tag slot bit definition (codec to controller)

## 12.2 Codec addressing

Table 28: Codec addressing examples

| CMD ADDR          | CMD DATA          | Codec ID (A1, A0)       | Read/Write        | Transfer        | Description  |
|-------------------|-------------------|-------------------------|-------------------|-----------------|--|
| slot #0<br>bit 14 | slot #0<br>bit 13 | slot #0<br>bits 1 and 0 | slot #1<br>bit 19 |                 |  |
| 0                 | 0                 | 00                      | x                 | idle            | No register data is transferred, slots 1 and 2 are not valid |
| 1                 | x                 | 00                      | 1                 | primary read    | Read for primary codec register                              |
| 1                 | 1                 | 00                      | 0                 | primary write   | Write to a primary codec register                            |
| x                 | x                 | 01                      | 1                 | secondary read  | Read from the 01 secondary codec register                    |
| x                 | x                 | 11                      | 0                 | secondary write | Write to a 11 secondary codec register                       |

### 12.2.1 Primary codec addressing

For addressing a primary codec, bits 1 and 0 of the Tag slot (codec ID A1 and A0) should be 0. The bits 13 and 14 are used for register data transfer. When the controller is not sending/receiving control data, it should be addressing the primary codec. When writing to a register, the bits 14 and 13 (ADDR and DATA valid) should be set to 1. When reading from a register, only the bit 14 is required to be 1.

### 12.2.2 Secondary codec addressing

When the Codec ID (A1,A0) is not 00, the controller is addressing a secondary codec in a read or write sequence. The direction is defined in the slot 1 read/write bit (bit 19).

## 12.3 PCM sample transfer

Since the AClink frame frequency is defined to be 48kHz, exchanging samples with the controller at a different sampling rate requires the support of on demand sample transfer (slot request). The UCB1510 will send samples to the controller and assert the slot 5 valid bit in the slot#0 (bit10)of the AClink frame. When it needs a new sample from the controller, it will put a 0 on the slot5req bit in the slot#1 (bit9) of the AClink frame. When the slot5req bit is 1, it indicates to the controller that no new sample is needed. When the DAC is not active, the slot5req bit is kept at 0.

## 12.4 Interrupt request from UCB1510

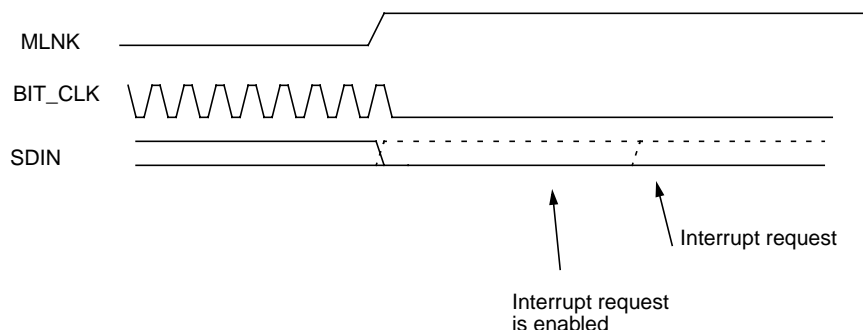

Fig 9. Setting the SDIN for interrupt request

### 12.4.1 When BIT\_CLK is running

The AClink is active and the interrupt request is transmitted by setting the interrupt bit of slot 12 in the AClink frame.

If UCB1510 is configured as a primary codec, this is the case when MLNK is set to 0.

If UCB1510 is configured as a secondary codec, this is the case whether MLNK is set to 0 or 1.

### 12.4.2 When BIT\_CLK is stopped

In order to request an interrupt, the UCB1510 will assert the SDIN pin, if MLNK is set to 1. BIT\_CLK is not needed for this to happen. This applies when UCB1510 is used as a primary or secondary codec.

If UCB1510 is configured as a primary codec, BIT\_CLK is stopped as a result of MLNK being set to 1.

If UCB1510 is configured as a secondary codec, BIT\_CLK is stopped when the controller shuts down the primary codec. For UCB1510 to generate interrupt while BIT\_CLK is stopped, MLNK has to be set to 1 before BIT\_CLK is stopped.

After BIT\_CLK is stopped, SDIN will be brought to 0, unless an interrupt asserts it to 1. It is recommended that a level triggered interrupt detection is used in case the interrupt request is asserted at the same time BIT\_CLK is stopped.

## 12.5 Wake-up request to the UCB1510

A cold reset will program the registers to their default value and will wake up the AClink.

When the AClink is not active (no BIT\_CLK present), a rising SYNC will cause a warm reset. If MLNK is set to 1, a rising RESET will also cause a warm reset. After a warm reset, MLNK will be reset to 0.

## 13. General purpose I/O

---

The UCB1510 has 8 programmable digital input/output (I/O) pins. These pins can be independently programmed for polarity, value, direction and interrupt through the GPIO control registers.

## 14. Interrupt generation

---

The UCB1510 contains a programmable interrupt control block.

The internal interrupt signal presents the 'OR' function of all interrupt status bits and can be used to give an interrupt to the system controller using the AClink interrupt protocol

The interrupt controller is implemented asynchronously. This provides the possibility to generate interrupts when BIT\_CLK is stopped, e.g. an interrupt can be generated in power down mode, when the state of one of the IO pins changes (e.g. ring detect).

## 15. Reset circuit and mode selection

---

The AC97 specification rev 2.1 describes a number of states and reset functions for a modem codec either in primary or secondary codec.

### 15.1 Resets

#### 15.1.1 Pulling the $\overline{\text{PON}}$ pin LOW

The  $\overline{\text{PON}}$  pin acts as a hardware reset and is typically connected to a power detection circuit.

#### 15.1.2 Activating the $\overline{\text{RESET}}$ pin

Pulling the  $\overline{\text{RESET}}$  pin low will start a cold or a warm reset sequence.

If the circuit is active ( $\text{MLNK} = 0$ ). A cold reset is started. The reset sequence will end after the rising edge of  $\overline{\text{RESET}}$ . Only then will the AClink be available. Vendor test modes are inactive as soon as the reset sequence starts so that mode sensing is possible.

If the MLNK bit is set when the  $\overline{\text{RESET}}$  pin is pulled low, a warm reset is activated when  $\overline{\text{RESET}}$  goes high again.

#### 15.1.3 Activating the SYNC pin when AClink is inactive

When the AClink is not active (no BIT\_CLK present), a rising SYNC will cause a warm reset.

#### 15.1.4 Writing reg 0x3C

When written, the reg 0x3C will initiate a register reset. All registers are set to their default values.

## 15.2 Vendor test modes

When starting a  $\overline{\text{RESET}}$  pin induced cold reset, the AClink pins are sensed for Vendor Test mode selection. BIT\_CLK does not need to be running at that moment

**Table 29: Mode selection with AC pins**

| SYNC | SDOUT | Mode  |
|------|-------|---|
| 0    | 0     | Normal mode, the AClink is operating properly.  |
| 0    | 1     | ATE test mode. All AClink pins are set to input thus allowing board level JTAG testing. |
| 1    | 0     | Vendor test mode.   |
| 1    | 1     | ATE test mode.  |

When the vendor test mode is activated, the vendor test register takes action. This mode is for test only and should not be used in normal operation. Exiting this mode requires a cold reset.

## 15.3 Primary/secondary codec selection

Secondary codec implementation is selected by wiring the  $\overline{\text{A0}}$  pin low.

When  $\overline{\text{A0}}$  is low (A0 is 1), the XTAL\_IN is used as  $\overline{\text{A1}}$  thus allowing '01' and '11' as secondary addresses. '10' is not possible. The ID register will then reflect the A1,A0. Details can be found in the description of register 0x3C.

When the UCB1510 is a secondary codec, it derives its internal clock from BIT\_CLK. BITCLK is therefore configured as input.

## 16. Limiting values

**Table 30: Limiting values**

*In accordance with the Absolute Maximum Rating System (IEC 60134). [1], [2]*

| Symbol            | Parameter                                  | Conditions | Min  | Max                   | Unit |
|-------------------|--|------------|------|-----------------------|------|
| $V_{\text{DD}}$   | supply voltage                             |            | -0.5 | +4.0                  | V    |
| $V_{\text{i}}$    | DC input voltage                           |            | -0.5 | $V_{\text{DD}} + 0.5$ | V    |
| $V_{\text{o}}$    | DC output voltage                          |            | -    | $V_{\text{DD}} + 0.5$ | V    |
| $I_{\text{i(d)}}$ | diode input current                        |            | -    | 10                    | mA   |
| $I_{\text{o(d)}}$ | diode output current                       |            | -    | 10                    | mA   |
| $I_{\text{o}}$    | continuous output current, digital outputs |            | -    | 4                     | mA   |
| $T_{\text{stg}}$  | storage temperature                        |            | -55  | +150                  | °C   |

- [1] Stresses above those listed under Absolute Maximum Ratings may cause permanent damage to the device. This is a stress rating only and functional operation of the device at these or any conditions other than those described in the Absolute Maximum Rating section of this specification is not implied
- [2] Parameters are valid over the ambient operating temperature unless otherwise specified. All voltages are with respect to  $V_{\text{SSD}}$ , unless otherwise noted.

## 17. Thermal characteristics

Table 31: Thermal characteristics

| Symbol        | Parameter   | Conditions | Value | Unit |
|---------------|---|------------|-------|------|
| $R_{th(j-a)}$ | thermal resistance from junction to ambient in free air |            | 55    | K/W  |

## 18. Static characteristics

Table 32: Static characteristics

$V_{SSD} = V_{SSA1} = 0\text{ V}$ ;  $T_{amb} = 25\text{ °C}$ ; all voltages referenced to  $V_{SSD}$ ; unless otherwise specified.

| Symbol         | Parameter                        | Conditions                           | Min           | Typ    | Max            | Unit |
|----------------|----------------------------------|--------------------------------------|---------------|--------|----------------|------|
| $V_{DDD}$      | digital supply voltage           |                                      | 3.0           | 3.3    | 3.6            | V    |
| $V_{DDA1}$     | analog supply voltage            |                                      | 3.0           | 3.3    | 3.6            | V    |
| $I_{DDD}$      | digital supply current           |                                      | [1]           | 19     | –              | mA   |
| $I_{DDA1}$     | digital supply current           | full functionality                   | [1]           | –      | –              | mA   |
| $I_{DDA2}$     | analog supply current            | Power down,<br>only oscillator is on |               | t.b.d. |                |      |
| $V_{IL}$       | LOW level input voltage          |                                      | –0.5          | –      | +0.2 $V_{DDD}$ | V    |
| $V_{IH}$       | HIGH level input voltage         |                                      | 0.8 $V_{DDD}$ | –      | 0.5 $V_{DDD}$  | V    |
| $V_{OL}$       | LOW level output voltage         | $I_{OL} = 4\text{ mA}$               | –             | –      | 0.4            | V    |
| $V_{OH}$       | HIGH level output voltage        | $I_{OH} = 4\text{ mA}$               | 0.8 $V_{DDD}$ | –      | –              | V    |
| $f_{BIT\_CLK}$ | serial interface clock frequency |                                      |               | 12.288 |                | MHz  |
| $T_{amb}$      | operating ambient temperature    |                                      | –20           | –      | 70             | °C   |

[1] Indicative value measured during the initial characterization.

## 19. Dynamic characteristics

**Table 33: Dynamic characteristics**

$V_{SSD} = V_{SSA} = 0$  V;  $V_{DDD} = V_{DDA} = 3.3$  V  $\pm 10\%$ ;  $T_{amb} = 25$  °C;  $V_{I(ref)} = 1.2$  V;  $f_{BIT\_CLK} = 12.288$  MHz; unless otherwise specified.

| Symbol                    | Parameter                          | Conditions  | Min      | Typ | Max  | Unit       |
|---------------------------|------------------------------------|---|----------|-----|------|------------|
| <b>Telecom input [1]</b>  |                                    |   |          |     |      |            |
| $f_{st}$                  | sample frequency                   |   | –        | 8   | –    | kHz        |
| $V_{i(rms)}$              | input voltage (RMS value)          | differentially applied to TINN and TINP; ADC[3:2] = 1 (6 dB) in register 0x46     | 330      | 370 | 410  | mV         |
| $V_{i(bias)}$             | DC bias voltage                    | TINN/TINP   | 1.2      | –   | 1.6  | V          |
| $\alpha_i$                | input gain                         |   | 0        | 6   | 18   | dB         |
|                           | input gain step size               | 2 LSBs ignored, Bit 3 step  | 4        | 6   | 8    | dB         |
| $Z_i$                     | input impedance                    |   | 25       | –   | –    | k $\Omega$ |
| S/N                       | signal-to-noise ratio              |   | 60       | 75  | –    | dB         |
| THD                       | total harmonic distortion          |   | –        | –75 | –60  | dB         |
| $LE_{(d)(ADC)}$           | ADC differential linearity error   |   | –        | –   | 2    | LSB        |
| RES                       | codec resolution                   |   | –        | 14  | –    | bit        |
| PBRR                      | pass-band ripple rejection         | $f_{plt} < f_{sig} < f_{pht}$ ; no voice filter                                   | [3], [6] | –   | 1.2  | dB         |
|                           |                                    | $f_{vht} < f_{sig} < f_{pht}$ ; voice filter activated                            | [3], [6] | –   | 1.2  | dB         |
| SBR <sub>vti</sub>        | stop-band rejection                | $f_{sig} < f_{vti}$ ; voice filter activated                                      | [3], [6] | 30  | –    | dB         |
| SBR <sub>sht</sub>        |                                    | $f_{sht} < f_{sig}$   | [3], [6] | 50  | –    | dB         |
| $D_{offset}$              | digital offset                     | no signal applied to input  | –        | –   | 50   | LSB        |
| $S_{sup}$                 | sidetone suppression effectiveness | 600 $\Omega$ line impedance; 1:1 transformer with 156 $\Omega$ winding resistance | 20       | –   | –    | dB         |
| <b>Telecom output [2]</b> |                                    |   |          |     |      |            |
| $f_{st}$                  | sample frequency                   |   | –        | 8   | –    | kHz        |
| $V_{o(rms)}$              | output voltage (RMS value)         | differentially measured between TOUTP and TOUTN                                   | 1.35     | –   | 1.85 | V          |
| $V_{o(bias)}$             | DC bias voltage                    | TOUTP/TOUTN; telecom O/P path enabled   | 1.2      | –   | 1.6  | V          |
| RES                       | codec resolution                   |   | –        | 14  | –    | bit        |
| S/N                       | signal-to-noise ratio              |   | 60       | 75  | –    | dB         |
| THD                       | total harmonic distortion          |   | –        | –75 | –    | dB         |
| PBRR                      | pass-band ripple rejection         |   | [4], [6] | –   | 1.2  | dB         |
| SBR                       | stop-band rejection                | $f_{sht} < f < f_{st}$  | [4], [6] | 50  | –    | dB         |
| $OBR_{(rms)}$             | out-of-band rejection (RMS value)  | $f > f_{st}$  | –        | –   | 25   | mV         |
| $Z_{o(load)}$             | load impedance                     |   | 600      | –   | –    | $\Omega$   |
| $E_{offset}$              | offset error                       |   | [5]      | –   | 100  | mV         |

**Table 33: Dynamic characteristics...continued**

$V_{SSD} = V_{SSA} = 0\text{ V}$ ;  $V_{DDD} = V_{DDA} = 3.3\text{ V} \pm 10\%$ ;  $T_{amb} = 25\text{ }^\circ\text{C}$ ;  $V_{I(ref)} = 1.2\text{ V}$ ;  $f_{BIT\_CLK} = 12.288\text{ MHz}$ ; unless otherwise specified.

| Symbol                                       | Parameter   | Conditions | Min | Typ          | Max  | Unit       |
|--|---|------------|-----|--------------|------|------------|
| <b>On-chip reference circuit</b>             |   |            |     |              |      |            |
| $V_{i(ref)}$                                 | reference voltage applied to VREFBYP                |            | 1.0 | 1.2          | 1.4  | V          |
| $t_{STRTU}$                                  | start-up time of internal reference voltage circuit |            | –   | –            | 1000 | ns         |
| <b>Xtal oscillator</b>                       |   |            |     |              |      |            |
| $f_{xtal}$                                   | Operating frequency                                 |            |     | 12.288       |      | MHz        |
| $Z_{xtal}$                                   | start-up time of internal reference voltage circuit |            |     | 10           |      | k $\Omega$ |
| <b>AClink control register data transfer</b> |   |            |     |              |      |            |
| $f_{acclk}$                                  | CLK input frequency                                 |            | 0   | 12.288       |      | MHz        |
| $D_{acclk}$                                  | CLK duty factor                                     |            | –   | 50           | –    | %          |
| <b>Reset circuit</b>                         |   |            |     |              |      |            |
| $t_{W(NRESET)}$                              | RESET pulse width                                   |            | 5   | –            | –    | ns         |
| $t_{W(rst)}$                                 | internal reset pulse width                          |            |     | $32 t_{CLK}$ | –    | ns         |

- [1] Additional test conditions:  $F_{sample} = 8\text{ kHz}$ ; input signal 1 kHz, 300 mV (RMS); Line1\_ADC\_ON = 1; TEL\_VOICE\_ENA = 0, input gain +6 dB
- [2] Additional test conditions:  $F_{sampling} 8\text{ kHz}$ ; 0 dB output attenuation; 90% of digital full scale input voltage; 1200  $\Omega$  load.
- [3] See Figure 10.
- [4] See Figure 11.
- [5] Deviation of the analog output from 0, with 0 code input to telecom output path.
- [6] All curves repeat around the sample frequency  $f_{sa}$  or  $f_{st}$  for telecom codec.

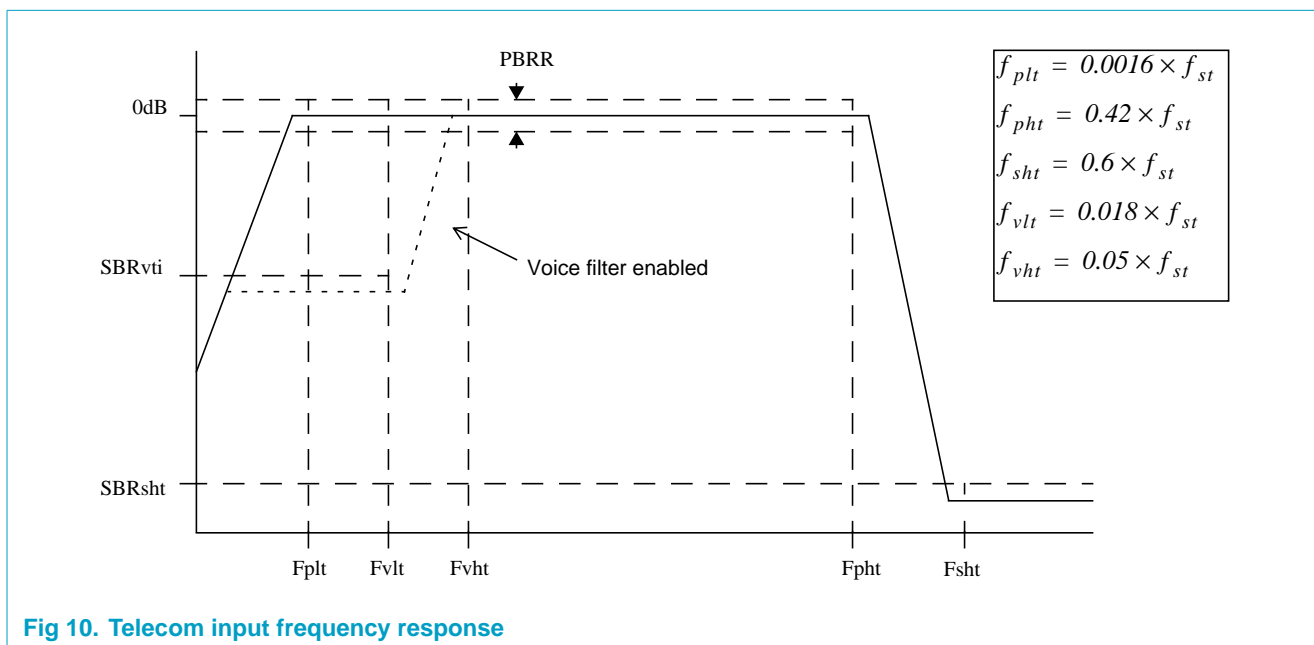

**Fig 10. Telecom input frequency response**



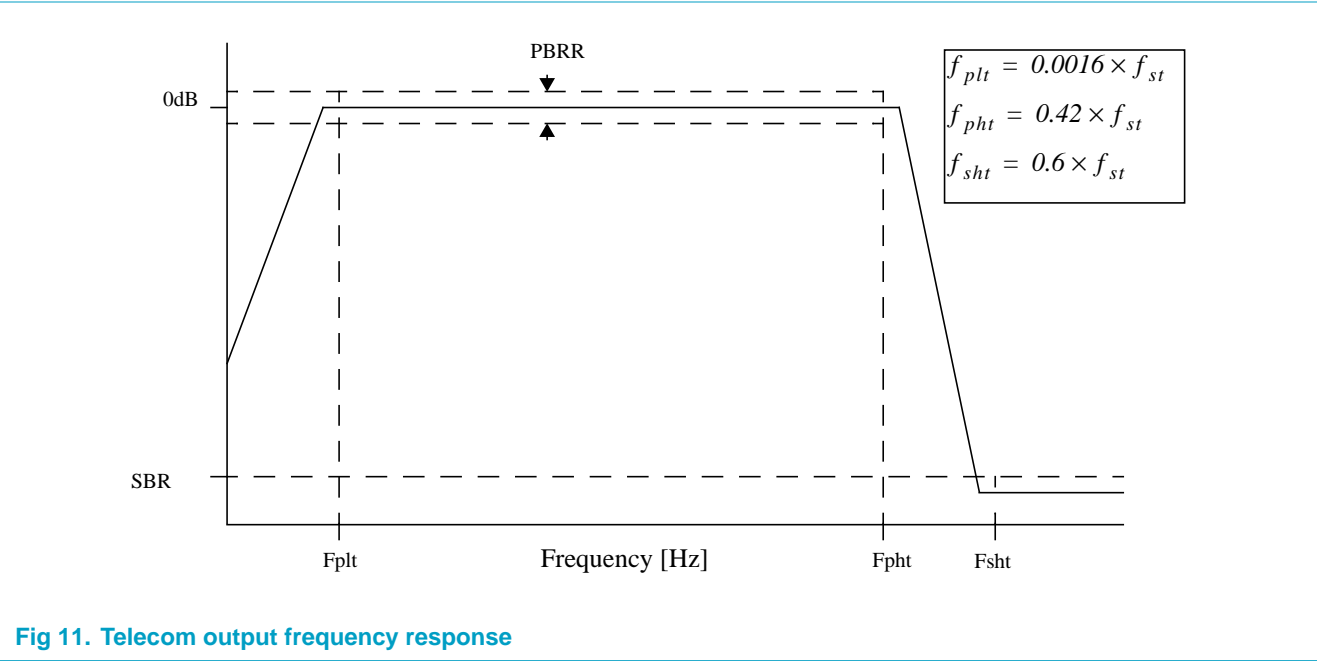

Fig 11. Telecom output frequency response

20. Package outline

SSOP28: plastic shrink small outline package; 28 leads; body width 5.3 mm

SOT341-1

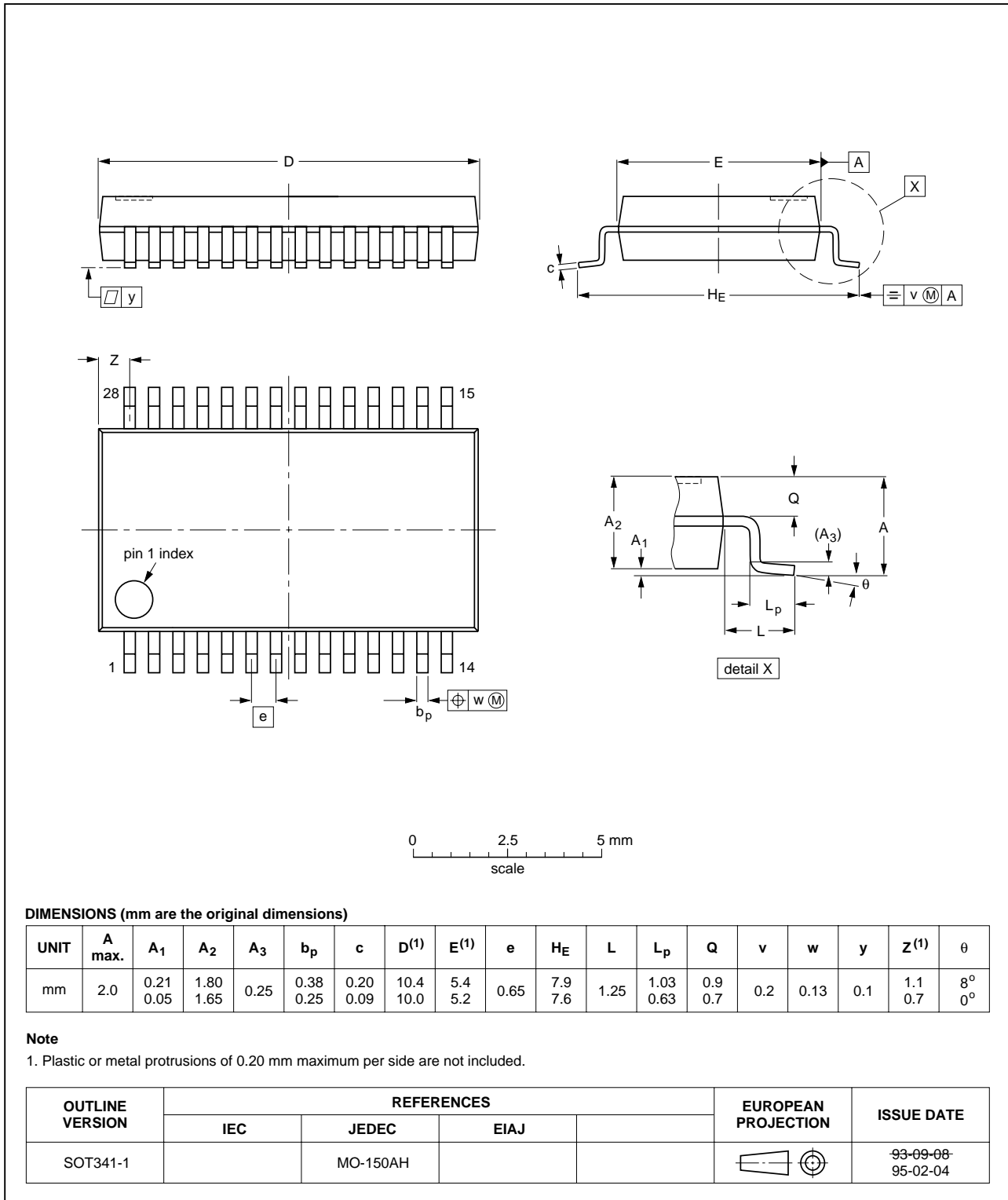

Fig 12. SSOP28 package; SOT341-1.

## 21. Soldering

### 21.1 Introduction to soldering surface mount packages

This text gives a very brief insight to a complex technology. A more in-depth account of soldering ICs can be found in our *Data Handbook IC26; Integrated Circuit Packages* (document order number 9398 652 90011).

There is no soldering method that is ideal for all surface mount IC packages. Wave soldering is not always suitable for surface mount ICs, or for printed-circuit boards with high population densities. In these situations reflow soldering is often used.

### 21.2 Reflow soldering

Reflow soldering requires solder paste (a suspension of fine solder particles, flux and binding agent) to be applied to the printed-circuit board by screen printing, stencilling or pressure-syringe dispensing before package placement.

Several methods exist for reflowing; for example, infrared/convection heating in a conveyor type oven. Throughput times (preheating, soldering and cooling) vary between 100 and 200 seconds depending on heating method.

Typical reflow peak temperatures range from 215 to 250 °C. The top-surface temperature of the packages should preferably be kept below 230 °C.

### 21.3 Wave soldering

Conventional single wave soldering is not recommended for surface mount devices (SMDs) or printed-circuit boards with a high component density, as solder bridging and non-wetting can present major problems.

To overcome these problems the double-wave soldering method was specifically developed.

If wave soldering is used the following conditions must be observed for optimal results:

- Use a double-wave soldering method comprising a turbulent wave with high upward pressure followed by a smooth laminar wave.
- For packages with leads on two sides and a pitch (e):
  - larger than or equal to 1.27 mm, the footprint longitudinal axis is **preferred** to be parallel to the transport direction of the printed-circuit board;
  - smaller than 1.27 mm, the footprint longitudinal axis **must** be parallel to the transport direction of the printed-circuit board.

The footprint must incorporate solder thieves at the downstream end.

- For packages with leads on four sides, the footprint must be placed at a 45° angle to the transport direction of the printed-circuit board. The footprint must incorporate solder thieves downstream and at the side corners.

During placement and before soldering, the package must be fixed with a droplet of adhesive. The adhesive can be applied by screen printing, pin transfer or syringe dispensing. The package can be soldered after the adhesive is cured.

Typical dwell time is 4 seconds at 250 °C. A mildly-activated flux will eliminate the need for removal of corrosive residues in most applications.

## 21.4 Manual soldering

Fix the component by first soldering two diagonally-opposite end leads. Use a low voltage (24 V or less) soldering iron applied to the flat part of the lead. Contact time must be limited to 10 seconds at up to 300 °C.

When using a dedicated tool, all other leads can be soldered in one operation within 2 to 5 seconds between 270 and 320 °C.

## 21.5 Package related soldering information

**Table 34: Suitability of surface mount IC packages for wave and reflow soldering methods**

| Package                                      | Soldering method                  |                       |
|--|-----------------------------------|-----------------------|
|  | Wave                              | Reflow <sup>[1]</sup> |
| BGA, LFBGA, SQFP, TFBGA                      | not suitable                      | suitable              |
| HBCC, HLQFP, HSQFP, HSOP, HTQFP, HTSSOP, SMS | not suitable <sup>[2]</sup>       | suitable              |
| PLCC <sup>[3]</sup> , SO, SOJ                | suitable                          | suitable              |
| LQFP, QFP, TQFP                              | not recommended <sup>[3][4]</sup> | suitable              |
| SSOP, TSSOP, VSO                             | not recommended <sup>[5]</sup>    | suitable              |

[1] All surface mount (SMD) packages are moisture sensitive. Depending upon the moisture content, the maximum temperature (with respect to time) and body size of the package, there is a risk that internal or external package cracks may occur due to vaporization of the moisture in them (the so called popcorn effect). For details, refer to the Drypack information in the *Data Handbook IC26; Integrated Circuit Packages; Section: Packing Methods*.

[2] These packages are not suitable for wave soldering as a solder joint between the printed-circuit board and heatsink (at bottom version) can not be achieved, and as solder may stick to the heatsink (on top version).

[3] If wave soldering is considered, then the package must be placed at a 45° angle to the solder wave direction. The package footprint must incorporate solder thieves downstream and at the side corners.

[4] Wave soldering is only suitable for LQFP, QFP and TQFP packages with a pitch (e) equal to or larger than 0.8 mm; it is definitely not suitable for packages with a pitch (e) equal to or smaller than 0.65 mm.

[5] Wave soldering is only suitable for SSOP and TSSOP packages with a pitch (e) equal to or larger than 0.65 mm; it is definitely not suitable for packages with a pitch (e) equal to or smaller than 0.5 mm.

## 22. Revision history

**Table 35: Revision history**

| Rev | Date   | CPCN | Description  |
|-----|--------|------|--|
| 01  | 991111 | -    | <b>Converted to DBII format.</b><br>The format of this specification has been redesigned to comply with Philips Semiconductors' new presentation and information standard. |

## 23. Data sheet status

| Datasheet status          | Product status | Definition <sup>[1]</sup>  |
|---------------------------|----------------|--|
| Objective specification   | Development    | This data sheet contains the design target or goal specifications for product development. Specification may change in any manner without notice.  |
| Preliminary specification | Qualification  | This data sheet contains preliminary data, and supplementary data will be published at a later date. Philips Semiconductors reserves the right to make changes at any time without notice in order to improve design and supply the best possible product. |
| Product specification     | Production     | This data sheet contains final specifications. Philips Semiconductors reserves the right to make changes at any time without notice in order to improve design and supply the best possible product.   |

[1] Please consult the most recently issued data sheet before initiating or completing a design.

## 24. Definitions

**Short-form specification** — The data in a short-form specification is extracted from a full data sheet with the same type number and title. For detailed information see the relevant data sheet or data handbook.

**Limiting values definition** — Limiting values given are in accordance with the Absolute Maximum Rating System (IEC 60134). Stress above one or more of the limiting values may cause permanent damage to the device. These are stress ratings only and operation of the device at these or at any other conditions above those given in the Characteristics sections of the specification is not implied. Exposure to limiting values for extended periods may affect device reliability.

**Application information** — Applications that are described herein for any of these products are for illustrative purposes only. Philips Semiconductors make no representation or warranty that such applications will be suitable for the specified use without further testing or modification.

## 25. Disclaimers

**Life support** — These products are not designed for use in life support appliances, devices, or systems where malfunction of these products can reasonably be expected to result in personal injury. Philips Semiconductors customers using or selling these products for use in such applications do so at their own risk and agree to fully indemnify Philips Semiconductors for any damages resulting from such application.

**Right to make changes** — Philips Semiconductors reserves the right to make changes, without notice, in the products, including circuits, standard cells, and/or software, described or contained herein in order to improve design and/or performance. Philips Semiconductors assumes no responsibility or liability for the use of any of these products, conveys no licence or title under any patent, copyright, or mask work right to these products, and makes no representations or warranties that these products are free from patent, copyright, or mask work right infringement, unless otherwise specified.

## Philips Semiconductors - a worldwide company

**Argentina:** see South America

**Australia:** Tel. +61 2 9704 8141, Fax. +61 2 9704 8139

**Austria:** Tel. +43 160 101, Fax. +43 160 101 1210

**Belarus:** Tel. +375 17 220 0733, Fax. +375 17 220 0773

**Belgium:** see The Netherlands

**Brazil:** see South America

**Bulgaria:** Tel. +359 268 9211, Fax. +359 268 9102

**Canada:** Tel. +1 800 234 7381

**China/Hong Kong:** Tel. +852 2 319 7888, Fax. +852 2 319 7700

**Colombia:** see South America

**Czech Republic:** see Austria

**Denmark:** Tel. +45 3 288 2636, Fax. +45 3 157 0044

**Finland:** Tel. +358 961 5800, Fax. +358 96 158 0920

**France:** Tel. +33 14 099 6161, Fax. +33 14 099 6427

**Germany:** Tel. +49 40 23 5360, Fax. +49 402 353 6300

**Hungary:** see Austria

**India:** Tel. +91 22 493 8541, Fax. +91 22 493 8722

**Indonesia:** see Singapore

**Ireland:** Tel. +353 17 64 0000, Fax. +353 17 64 0200

**Israel:** Tel. +972 36 45 0444, Fax. +972 36 49 1007

**Italy:** Tel. +39 039 203 6838, Fax +39 039 203 6800

**Japan:** Tel. +81 33 740 5130, Fax. +81 3 3740 5057

**Korea:** Tel. +82 27 09 1412, Fax. +82 27 09 1415

**Malaysia:** Tel. +60 37 50 5214, Fax. +60 37 57 4880

**Mexico:** Tel. +9-5 800 234 7381

**Middle East:** see Italy

**For all other countries apply to:** Philips Semiconductors, International Marketing & Sales Communications, Building BE, P.O. Box 218, 5600 MD EINDHOVEN, The Netherlands, Fax. +31 40 272 4825

**Netherlands:** Tel. +31 40 278 2785, Fax. +31 40 278 8399

**New Zealand:** Tel. +64 98 49 4160, Fax. +64 98 49 7811

**Norway:** Tel. +47 22 74 8000, Fax. +47 22 74 8341

**Philippines:** Tel. +63 28 16 6380, Fax. +63 28 17 3474

**Poland:** Tel. +48 22 5710 000, Fax. +48 22 5710 001

**Portugal:** see Spain

**Romania:** see Italy

**Russia:** Tel. +7 095 755 6918, Fax. +7 095 755 6919

**Singapore:** Tel. +65 350 2538, Fax. +65 251 6500

**Slovakia:** see Austria

**Slovenia:** see Italy

**South Africa:** Tel. +27 11 471 5401, Fax. +27 11 471 5398

**South America:** Tel. +55 11 821 2333, Fax. +55 11 829 1849

**Spain:** Tel. +34 33 01 6312, Fax. +34 33 01 4107

**Sweden:** Tel. +46 86 32 2000, Fax. +46 86 32 2745

**Switzerland:** Tel. +41 14 88 2686, Fax. +41 14 81 7730

**Taiwan:** Tel. +886 22 134 2865, Fax. +886 22 134 2874

**Thailand:** Tel. +66 27 45 4090, Fax. +66 23 98 0793

**Turkey:** Tel. +90 216 522 1500, Fax. +90 216 522 1813

**Ukraine:** Tel. +380 44 264 2776, Fax. +380 44 268 0461

**United Kingdom:** Tel. +44 208 730 5000, Fax. +44 208 754 8421

**United States:** Tel. +1 800 234 7381

**Uruguay:** see South America

**Vietnam:** see Singapore

**Yugoslavia:** Tel. +381 11 62 5344, Fax. +381 11 63 5777

**Internet:** <http://www.semiconductors.philips.com>

(SCA68)

## Contents

|           |  |           |           |  |           |
|-----------|--|-----------|-----------|--|-----------|
| <b>1</b>  | <b>Description</b> . . . . .                         | <b>1</b>  | <b>15</b> | <b>Reset circuit and mode selection</b> . . . . .          | <b>20</b> |
| <b>2</b>  | <b>Features</b> . . . . .                            | <b>1</b>  | 15.1      | Resets . . . . .   | 20        |
| <b>3</b>  | <b>Applications</b> . . . . .                        | <b>1</b>  | 15.1.1    | Pulling the $\overline{\text{PON}}$ pin LOW . . . . .      | 20        |
| <b>4</b>  | <b>Ordering information</b> . . . . .                | <b>2</b>  | 15.1.2    | Activating the $\overline{\text{RESET}}$ pin . . . . .     | 20        |
| <b>5</b>  | <b>Block diagram</b> . . . . .                       | <b>2</b>  | 15.1.3    | Activating the SYNC pin when AClink is inactive . . . . .  | 20        |
| <b>6</b>  | <b>Pinning information</b> . . . . .                 | <b>3</b>  | 15.1.4    | Writing reg 0x3C . . . . .                                 | 20        |
| 6.1       | Pinning . . . . .                                    | 3         | 15.2      | Vendor test modes . . . . .                                | 21        |
| 6.2       | Pin description . . . . .                            | 3         | 15.3      | Primary/secondary codec selection . . . . .                | 21        |
| <b>7</b>  | <b>Functional description</b> . . . . .              | <b>5</b>  | <b>16</b> | <b>Limiting values</b> . . . . .                           | <b>21</b> |
| <b>8</b>  | <b>Telecom codec</b> . . . . .                       | <b>5</b>  | <b>17</b> | <b>Thermal characteristics</b> . . . . .                   | <b>22</b> |
| 8.1       | Digital filters . . . . .                            | 6         | <b>18</b> | <b>Static characteristics</b> . . . . .                    | <b>22</b> |
| 8.2       | Analog interface . . . . .                           | 7         | <b>19</b> | <b>Dynamic characteristics</b> . . . . .                   | <b>23</b> |
| <b>9</b>  | <b>On-chip reference circuit</b> . . . . .           | <b>8</b>  | <b>20</b> | <b>Package outline</b> . . . . .                           | <b>26</b> |
| <b>10</b> | <b>Power supply strategy</b> . . . . .               | <b>8</b>  | <b>21</b> | <b>Soldering</b> . . . . .                                 | <b>27</b> |
| <b>11</b> | <b>Register definition</b> . . . . .                 | <b>9</b>  | 21.1      | Introduction to soldering surface mount packages . . . . . | 27        |
| 11.1      | Supported registers . . . . .                        | 9         | 21.2      | Reflow soldering . . . . .                                 | 27        |
| 11.2      | Register detail . . . . .                            | 9         | 21.3      | Wave soldering . . . . .                                   | 27        |
| 11.2.1    | Extended Modem ID . . . . .                          | 9         | 21.4      | Manual soldering . . . . .                                 | 28        |
| 11.2.2    | Extended Modem Status and Control . . . . .          | 10        | 21.5      | Package related soldering information . . . . .            | 28        |
| 11.2.3    | Line 1 Sample Rate . . . . .                         | 10        | <b>22</b> | <b>Revision history</b> . . . . .                          | <b>28</b> |
| 11.2.4    | Line 1 DAC/ADC Level . . . . .                       | 11        | <b>23</b> | <b>Data sheet status</b> . . . . .                         | <b>29</b> |
| 11.2.5    | GPIO Pin Configuration . . . . .                     | 11        | <b>24</b> | <b>Definitions</b> . . . . .                               | <b>29</b> |
| 11.2.6    | GPIO Pin Polarity . . . . .                          | 11        | <b>25</b> | <b>Disclaimers</b> . . . . .                               | <b>29</b> |
| 11.2.7    | GPIO Pin Sticky . . . . .                            | 12        |           |  |           |
| 11.2.8    | GPIO Wake-up Mask . . . . .                          | 12        |           |  |           |
| 11.2.9    | GPIO Pin Status . . . . .                            | 12        |           |  |           |
| 11.2.10   | Miscellaneous Modem AFE Status and Control . . . . . | 13        |           |  |           |
| 11.2.11   | Vendor Specific Codec Control . . . . .              | 14        |           |  |           |
| 11.2.12   | Vendor Specific Mode Control . . . . .               | 14        |           |  |           |
| 11.2.13   | Vendor specific Test Control . . . . .               | 14        |           |  |           |
| 11.2.14   | Vendor ID1 . . . . .                                 | 15        |           |  |           |
| 11.2.15   | Vendor ID2 . . . . .                                 | 15        |           |  |           |
| 11.3      | Register reset modes . . . . .                       | 15        |           |  |           |
| 11.3.1    | Warm reset . . . . .                                 | 15        |           |  |           |
| 11.3.2    | Cold reset . . . . .                                 | 15        |           |  |           |
| 11.3.3    | Register reset . . . . .                             | 15        |           |  |           |
| <b>12</b> | <b>AC97 interface</b> . . . . .                      | <b>16</b> |           |  |           |
| 12.1      | Control register data transfer . . . . .             | 16        |           |  |           |
| 12.2      | Codec addressing . . . . .                           | 18        |           |  |           |
| 12.2.1    | Primary codec addressing . . . . .                   | 18        |           |  |           |
| 12.2.2    | Secondary codec addressing . . . . .                 | 18        |           |  |           |
| 12.3      | PCM sample transfer . . . . .                        | 18        |           |  |           |
| 12.4      | Interrupt request from UCB1510 . . . . .             | 19        |           |  |           |
| 12.4.1    | When BIT_CLK is running . . . . .                    | 19        |           |  |           |
| 12.4.2    | When BIT_CLK is stopped . . . . .                    | 19        |           |  |           |
| 12.5      | Wake-up request to the UCB1510 . . . . .             | 19        |           |  |           |
| <b>13</b> | <b>General purpose I/O</b> . . . . .                 | <b>20</b> |           |  |           |
| <b>14</b> | <b>Interrupt generation</b> . . . . .                | <b>20</b> |           |  |           |



**PHILIPS**

*Let's make things better.*