

Document No.	853-1512
ECN No.	00733
Date of Issue	October 17, 1990
Status	Product Specification
ACL Products	

AC11979: Preliminary Specification

ACT11979: Product Specification

8-bit multiplexed I/O read-back register

FEATURES

- Octal bus interface
- 3-State buffers
- Output capability: ± 24 mA
- CMOS (AC) and TTL (ACT) voltage level inputs
- 50 Ω incident wave switching
- Center-pin V_{CC} and ground configuration to minimize high-speed switching noise
- I_{CC} category: MSI

DESCRIPTION

The 74AC/ACT11979 high-performance CMOS devices combine very high speed and high output drive comparable to the most advanced TTL families.

The 74AC/ACT11979 device is an 8-bit multiplexed I/O read-back register. When the Output Enable (\overline{OE}) input is held High, it loads data on the rising edge of the Clock (CP). When the Clock is held High or Low, the data is held in the registers. When the Output Enable is Low, the data held in the register is visible on the I/O pins (I/O_n).

QUICK REFERENCE DATA

SYMBOL	PARAMETER	CONDITIONS $T_{amb} = 25^\circ\text{C}; \text{GND} = 0\text{V}$ $V_{CC} = 5.0\text{V}$	TYPICAL		UNIT
			AC	ACT	
t_{PZH}/t_{PZL}	Propagation delay \overline{OE} to I/O_n	$C_L = 50\text{pF}$	6.2	6.2	ns
C_{PD}	Power dissipation capacitance ¹	$f = 1\text{MHz}; \text{Disabled}$	12	15	pF
C_{IN}	Input capacitance	$V_I = 0\text{V}$ or V_{CC}	3.5	3.5	pF
$C_{I/O}$	I/O capacitance	$V_{I/O} = 0\text{V}$ or $V_{CC}; \text{Disabled}$	8.5	8.5	pF
I_{LATCH}	Latch-up current	Per Jeduc JC40.2 Standard 17	500	500	mA

Note:

1. C_{PD} is used to determine the dynamic power dissipation (P_D in μW):

$$P_D = C_{PD} \times V_{CC}^2 \times f_i + \sum (C_L \times V_{CC}^2 \times f_o)$$

f_i = input frequency in MHz, C_L = output load capacitance in pF,

f_o = output frequency in MHz, V_{CC} = supply voltage in V,

$\sum (C_L \times V_{CC}^2 \times f_o)$ = sum of outputs

ORDERING INFORMATION

PACKAGES	TEMPERATURE RANGE	ORDER CODE
16-pin plastic DIP (300mil-wide)	-40°C to +85°C	74AC11979N 74ACT11979N
16-pin plastic SO (150mil-wide)	-40°C to +85°C	74AC11979D 74ACT11979D

PIN CONFIGURATION

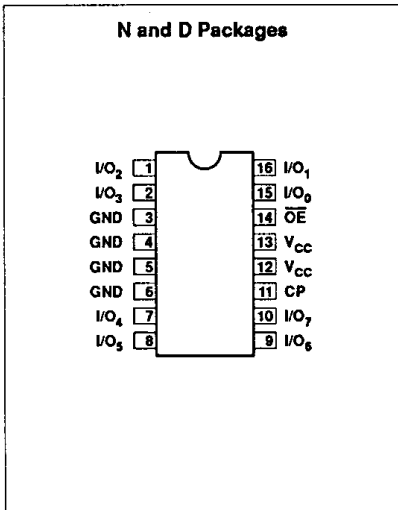

LOGIC SYMBOL

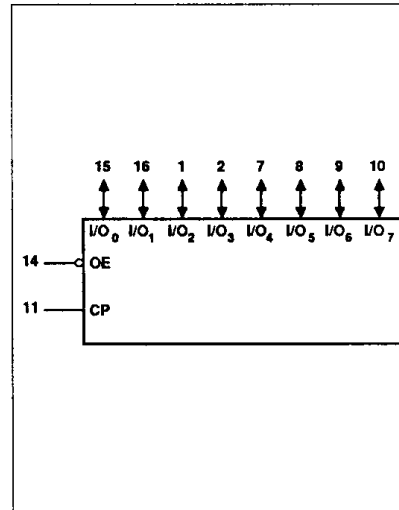

LOGIC SYMBOL (IEEE/IEC)

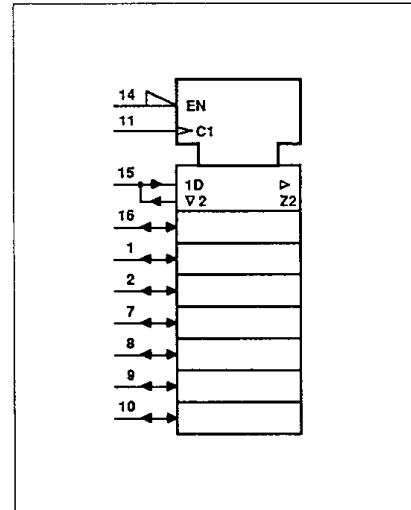

8-bit multiplexed I/O read-back register**74AC/ACT11979****PIN DESCRIPTION**

PIN NUMBER	SYMBOL	NAME AND FUNCTION
14	\overline{OE}	Output enable input (active Low)
11	CP	Clock input
15, 16, 1, 2 7, 8, 9, 10	$I/O_0 - I/O_7$	Data inputs/outputs (3-state)
3, 4, 5, 6	GND	Ground (0V)
12, 13	V_{CC}	Positive supply voltage

FUNCTION TABLE

\overline{OE}	CP	I/O_n	OPERATION
L	X*	Data out	Output data
H	↑	l h	Load data
H	H L	Z	Hold data

H = High voltage level

h = High voltage level one set-up time prior to the Low-to-High clock transition

L = Low voltage level

l = Low voltage level one set-up time prior to the Low-to-High clock transition

X = Don't care

↑ = Low-to-High clock transition

Z = High-impedance (OFF) state

* The register is loaded on any Low-to-High transition

8-bit multiplexed I/O read-back register

74AC/ACT11979

LOGIC DIAGRAM

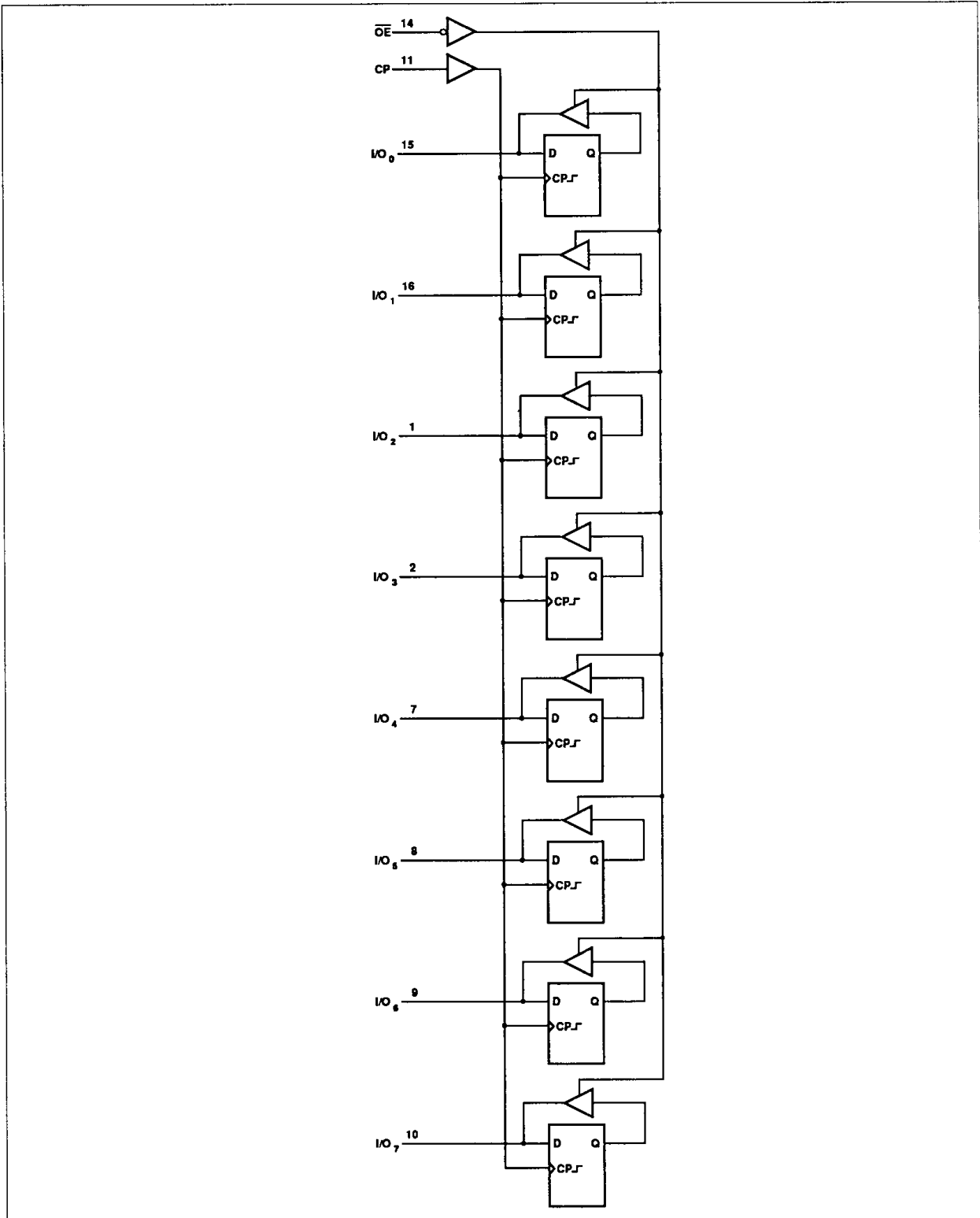

8-bit multiplexed I/O read-back register**74AC/ACT11979****RECOMMENDED OPERATING CONDITIONS**

SYMBOL	PARAMETER	74AC11979			74ACT11979			UNIT
		Min	Nom	Max	Min	Nom	Max	
V_{CC}	DC supply voltage	3.0 ¹	5.0	5.5	4.5	5.0	5.5	V
V_I	Input voltage	0		V_{CC}	0		V_{CC}	V
V_O	Output voltage	0		V_{CC}	0		V_{CC}	V
$\Delta V/\Delta t$	Input transition rise or fall rate	0		10	0		10	ns/V
T_{amb}	Operating free-air temperature range	-40		+85	-40		+85	°C

NOTE:

1. No electrical or switching characteristics are specified at $V_{CC} < 3V$. Operation between 2V and 3V is not recommended, but within that range, a device output will maintain a previously established logic state.

ABSOLUTE MAXIMUM RATINGS¹

SYMBOL	PARAMETER	TEST CONDITIONS	RATING	UNIT
V_{CC}	DC supply voltage		-0.5 TO +7.0	V
I_{IK} or V_I	DC input diode current ²	$V_I < 0$	-20	mA
		$V_I > V_{CC}$	20	
	DC input voltage		-0.5 to $V_{CC} + 0.5$	V
I_{OK} or V_O	DC output diode current ²	$V_O < 0$	-50	mA
		$V_O > V_{CC}$	50	
	DC output voltage		-0.5 to $V_{CC} + 0.5$	V
I_O	DC output source or sink current per output pin	$V_O = 0$ to V_{CC}	± 50	mA
I_{CC} or I_{GND}	DC V_{CC} current		± 200	mA
	DC ground current		± 200	
T_{STG}	Storage temperature		-65 to 150	°C
P_{TOT}	Power dissipation per package	Above 70°C; derate linearly by 8mW/K	500	mW
	Power dissipation per package Plastic surface mount (SO)	Above 70°C; derate linearly by 8mW/K	400	mW

NOTES:

- Stresses beyond those listed may cause permanent damage to the device. These are stress ratings only and functional operation of the device at these or any other conditions beyond those indicated under "recommended operating conditions" is not implied. Exposure to absolute-maximum-rated conditions for extended periods may affect device reliability.
- The input and output voltage ratings may be exceeded if the input and output current ratings are observed.

8-bit multiplexed I/O read-back register

74AC/ACT11979

DC ELECTRICAL CHARACTERISTICS

SYMBOL	PARAMETER	TEST CONDITIONS	V _{CC}	74AC11979				74ACT11979				UNIT	
				T _{amb} = +25°C		T _{amb} = -40°C to +85°C		T _{amb} = +25°C		T _{amb} = -40°C to +85°C			
				Min	Max	Min	Max	Min	Max	Min	Max		
V _{IH}	High-level input voltage		3.0	2.10		2.10						V	
			4.5	3.15		3.15		2.0		2.0			
			5.5	3.85		3.85		2.0		2.0			
V _{IL}	Low-level input voltage		3.0		0.90		0.90					V	
			4.5		1.35		1.35		0.8		0.8		
			5.5		1.65		1.65		0.8		0.8		
V _{OH}	High-level output voltage	V _I = V _{IL} or V _{IH}	I _{OH} = -50µA	3.0	2.9		2.9					V	
				4.5	4.4		4.4		4.4		4.4		
				5.5	5.4		5.4		5.4		5.4		
			I _{OH} = -4mA	3.0	2.58		2.48						
				4.5	3.94		3.8		3.94		3.8		
				5.5	4.94		4.8		4.94		4.8		
I _{OH} = -75mA ¹	3.0			3.85				3.85					
	5.5												
V _{OL}	Low-level output voltage	V _I = V _{IL} or V _{IH}	I _{OL} = 50µA	3.0		0.1		0.1				V	
				4.5		0.1		0.1		0.1			0.1
				5.5		0.1		0.1		0.1			0.1
			I _{OL} = 12mA	3.0		0.36		0.44					
				4.5		0.36		0.44		0.36			0.44
			I _{OL} = 24mA	3.0		0.36		0.44		0.36			0.44
				5.5		0.36		0.44		0.36			0.44
I _{OL} = 75mA ¹	3.0				1.65				1.65				
I _I	Input leakage current	V _I = V _{CC} or GND	5.5		±0.1		±1.0		±0.1		±1.0	µA	
I _{OZ}	3-State output off-state current	V _I = V _{IL} or V _{IH} , V _O = V _{CC} or GND	5.5		±0.5		5.0		±0.5		5.0	µA	
I _{CC}	Quiescent supply current	V _I = V _{CC} or GND, I _O = 0mA	5.5		8.0		80		8.0		80	µA	
ΔI _{CC}	Supply current, TTL inputs High ²	One input at 3.4V, other inputs at V _{CC} or GND	5.5						0.9		1.0	mA	

NOTES:

1. Not more than one output should be tested at a time, and the duration of the test should not exceed 10ms.
2. This is the increase in supply current for each input that is at one of the specified TTL voltage levels rather than 0V or V_{CC}.

8-bit multiplexed I/O read-back register

74AC/ACT11979

AC ELECTRICAL CHARACTERISTICS AT 3.0V \pm 0.3V

SYMBOL	PARAMETER	WAVEFORM	74AC11979					UNIT
			T _{amb} = +25°C			T _{amb} = -40°C to +85°C		
			Min	Typ	Max	Min	Max	
t _{PZH} t _{PZL}	Output enable time to High and Low level	1	3.6 5.0	7.9 9.2	9.9 11.1	3.6 5.0	10.9 12.4	ns
t _{PHZ} t _{PLZ}	Output disable time from High and Low level	1	4.1 3.7	7.2 6.6	8.7 8.2	4.1 3.7	9.1 8.5	ns
t _w	CP pulse width High or Low	2	4.0			4.0		ns
t _s	Setup time I/O _n to CP	2	6.0			6.0		ns
t _h	Hold time CP to I/O _n	2	0.0			0.0		ns

AC ELECTRICAL CHARACTERISTICS AT 5.0V \pm 0.5V

SYMBOL	PARAMETER	WAVEFORM	74AC11979					UNIT
			T _{amb} = +25°C			T _{amb} = -40°C to +85°C		
			Min	Typ	Max	Min	Max	
t _{PZH} t _{PZL}	Output enable time to High and Low level	1	3.1 4.4	5.4 7.0	7.3 9.2	3.1 4.4	7.9 10.0	ns
t _{PHZ} t _{PLZ}	Output disable time from High and Low level	1	3.8 3.4	5.8 5.5	7.8 7.5	3.8 3.4	8.2 7.8	ns
t _w	CP pulse width High or Low	2	3.0			3.0		ns
t _s	Setup time I/O _n to CP	2	5.0			5.0		ns
t _h	Hold time CP to I/O _n	2	0.5			0.5		ns

AC ELECTRICAL CHARACTERISTICS AT 5.0V \pm 0.5V

SYMBOL	PARAMETER	WAVEFORM	74ACT11979					UNIT
			T _{amb} = +25°C			T _{amb} = -40°C to +85°C		
			Min	Typ	Max	Min	Max	
t _{PZH} t _{PZL}	Output enable time to High and Low level	1	2.4 3.0	5.8 7.5	9.1 11.3	2.4 3.0	9.9 12.4	ns
t _{PHZ} t _{PLZ}	Output disable time from High and Low level	1	4.5 4.2	6.8 6.7	9.4 9.3	4.5 4.2	10.0 9.8	ns
t _w	CP pulse width High or Low	2	4.0			4.0		ns
t _s	Setup time I/O _n to CP	2	4.5			4.5		ns
t _h	Hold time CP to I/O _n	2	1.5			1.5		ns

8-bit multiplexed I/O read-back register

74AC/ACT11979

AC WAVEFORMS

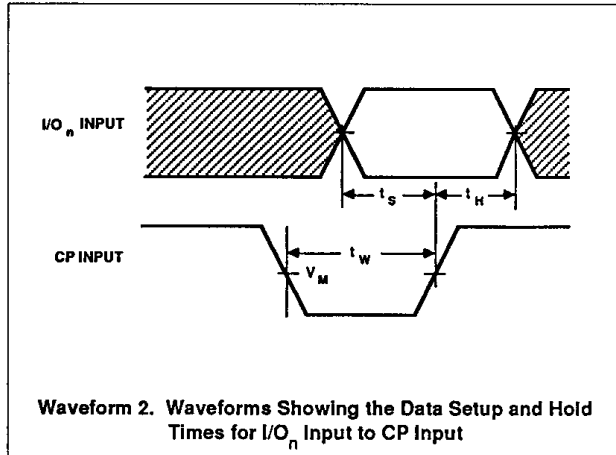
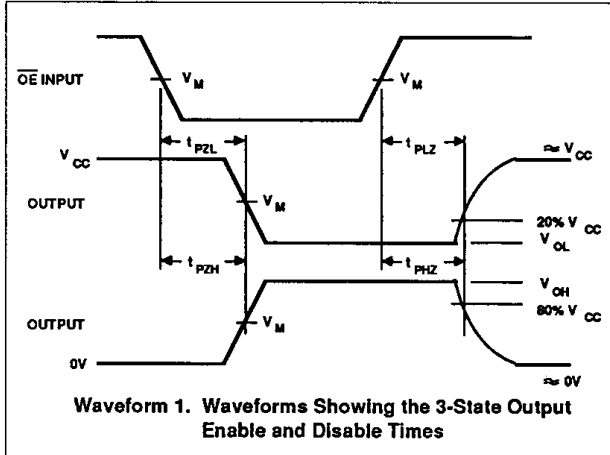

WAVEFORM CONDITIONS

	INPUTS	OUTPUTS
AC	$V_{IN} = \text{GND to } V_{CC}$ $V_M = 50\% V_{CC}$	$V_{OUT} = V_{OL} \text{ to } V_{OH}$
ACT	$V_{IN} = \text{GND to } 3.0\text{V}$ $V_M = 1.5\text{V}$	$V_M = 50\% V_{CC}$

TEST CIRCUIT

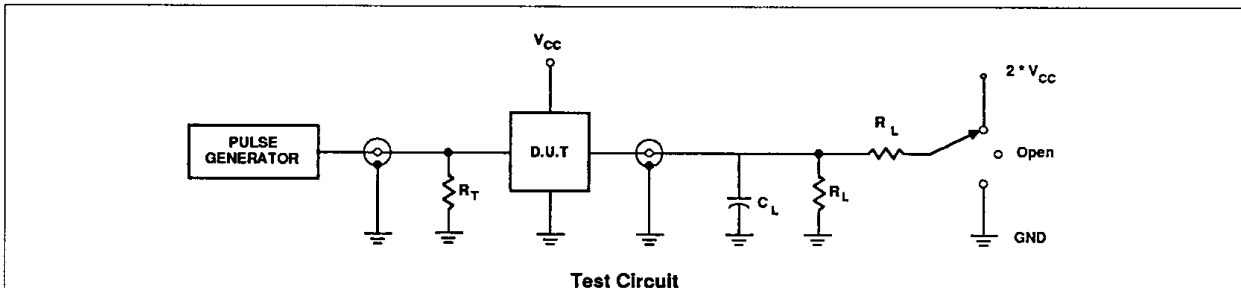

TEST	S1
t_{PLH}/t_{PHL}	Open
t_{PLZ}/t_{PZL}	$2 \cdot V_{CC}$
t_{PHZ}/t_{PZH}	GND

SWITCH POSITION

DEFINITIONS

C_L = Load capacitance, 50pF; includes jig and probe capacitance
 R_L = Load resistor, 500Ω
 R_T = Termination resistance should be equal to Z_{OUT} of pulse generators
 Input pulses: $PRR \leq 10\text{MHz}$
 $t_r = t_f = 3\text{ns}$