

Document No.	
ECN No.	
Date of Issue	May 8, 1990
Status	Preliminary Specification
ACL Products	

# 74AC/ACT11163

## Synchronous presettable 4-bit binary counter, synchronous reset

### FEATURES

- Synchronous counting and loading
- Two count enable inputs for n-bit cascading
- Positive edge-triggered clock
- Synchronous reset
- Output capability:  $\pm 24\text{mA}$
- CMOS (AC) and TTL (ACT) voltage level inputs
- $50\Omega$  incident wave switching
- Center-pin  $V_{CC}$  and ground configuration to minimize high-speed switching noise
- $I_{CC}$  category: MSI

### DESCRIPTION

The 74AC/ACT11163 high-performance CMOS devices combine very high speed and high output drive comparable to the most advanced TTL families.

The 74AC/ACT11163 4-bit synchronous presettable binary counters feature an internal carry look-ahead and can be used for high-speed counting. Synchronous operation is provided by having all flip-flops clocked simultaneously on the positive-going edge of the clock.

### QUICK REFERENCE DATA

SYMBOL	PARAMETER	CONDITIONS $T_{amb} = 25^\circ\text{C}; \text{GND} = 0\text{V};$ $V_{CC} = 5.0\text{V}$	TYPICAL		UNIT
			AC	ACT	
$t_{PLH}/t_{PHL}$	Propagation delay $CP_n$ to $Q_n$ ( $\overline{PE} = \text{High}$ )	$C_L = 50\text{pF}$	5.4	5.9	ns
$C_{PD}$	Power dissipation capacitance <sup>1</sup>	$f = 1\text{MHz}; C_L = 50\text{pF}$	52	51	pF
$C_{IN}$	Input capacitance	$V_I = 0\text{V}$ or $V_{CC}$	4.0	4.0	pF
$I_{LATCH}$	Latch-up current	Per JEDEC JC40.2 Standard 17	500	500	mA
$f_{MAX}$	Maximum clock frequency	$C_L = 50\text{pF}$	170	155	MHz

#### Note:

1.  $C_{PD}$  is used to determine the dynamic power dissipation ( $P_D$  in  $\mu\text{W}$ ):

$$P_D = C_{PD} \times V_{CC}^2 \times f_I + \sum (C_L \times V_{CC}^2 \times f_O) \text{ where:}$$

$f_I$  = input frequency in MHz,  $C_L$  = output load capacitance in pF,

$f_O$  = output frequency in MHz,  $V_{CC}$  = supply voltage in V,

$\sum (C_L \times V_{CC}^2 \times f_O)$  = sum of outputs

### ORDERING INFORMATION

PACKAGES	TEMPERATURE RANGE	ORDER CODE
20-pin plastic DIP (300mil-wide)	-40°C to +85°C	74AC11163N 74ACT11163N
20-pin plastic SOL (300mil-wide)	-40°C to +85°C	74AC11163D 74ACT11163D

### PIN CONFIGURATION

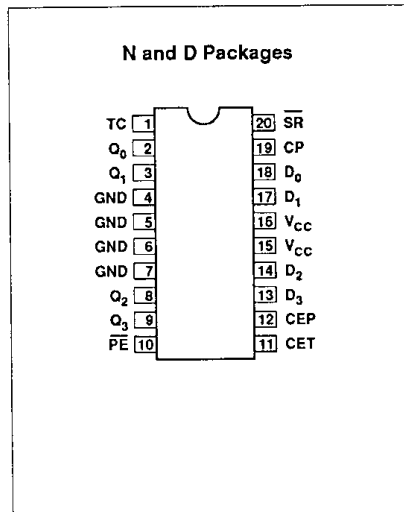

### LOGIC SYMBOL

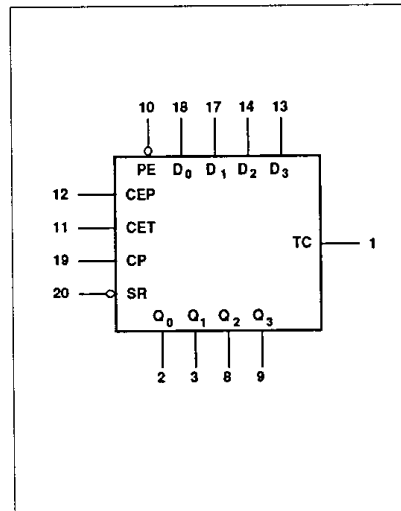

### LOGIC SYMBOL (IEEE/IEC)

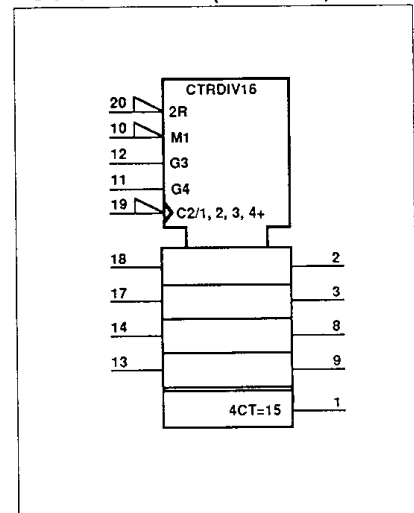

## Synchronous presettable 4-bit binary counter, synchronous reset

### 74AC/ACT11163

The outputs of the counters may be preset to High or Low levels. A Low level at the Parallel Enable ( $\overline{PE}$ ) input disables the counting action and causes the data at the  $D_0 - D_3$  inputs to be loaded into the counter on the rising edge of the clock. Preset takes place regardless of the levels at Count Enable (CEP, CET) inputs.

A Low level at the Reset ( $\overline{SR}$ ) input sets all four outputs of the flip-flops ( $Q_0 - Q_3$ ) to Low levels after the next positive-going transition on the clock (CP) input. This action occurs regardless of the levels at  $\overline{PE}$ , CET, and CEP inputs. This synchronous reset feature enables the designer to modify the maximum count with only one external NAND gate.

The carry look-ahead simplifies serial cascading of the counters. Both Count Enable inputs (CEP and CET) must be High to count. The CET input is fed forward to enable the Terminal Count (TC) output. The TC output thus enabled will produce a High output pulse of a duration approximately equal to the High level output of  $Q_0$ . This pulse can be used to enable the next cascaded stage.

### PIN DESCRIPTION

PIN NUMBER	SYMBOL	NAME AND FUNCTION
20	$\overline{SR}$	Synchronous reset (active Low)
19	CP	Clock input (Low-to-High edge-triggered)
18, 17, 14, 13	$D_0 - D_3$	Data inputs
12	CEP	Count enable input
10	$\overline{PE}$	Parallel enable input (active Low)
11	CET	Count enable carry input
2, 3, 8, 9	$Q_0 - Q_3$	Counter outputs
1	TC	Terminal count output
4, 5, 6, 7	GND	Ground (0V)
15, 16	$V_{CC}$	Positive supply voltage

### FUNCTION TABLE

OPERATING MODE	INPUTS						OUTPUTS	
	$\overline{SR}$	CP	CEP	CET	$\overline{PE}$	$D_n$	$Q_n$	TC
Reset (clear)	l	↑	X	X	X	X	L	L
Parallel load	h	↑	X	X	l	l	L	L
	h	↑	X	X	l	h	H	(1)
Count	h	↑	h	h	h	X	count	(1)
Hold (do nothing)	h	X	l	X	h	X	$q_n$	(1)
	h	X	X	l	h	X	$q_n$	L

H = High voltage level

L = Low voltage level

h = High voltage level one setup time prior to the Low-to High clock transition

l = Low voltage level one setup time prior to the Low-to High clock transition

X = Don't care

q = State of the referenced output prior to the Low-to High clock transition

↑ = Low-to-High clock transition

#### NOTE:

- The TC output is High when CET is High and the counter is at Terminal Count (HHHH).

# Synchronous presettable 4-bit binary counter, synchronous reset

74AC/ACT11163

STATE DIAGRAM

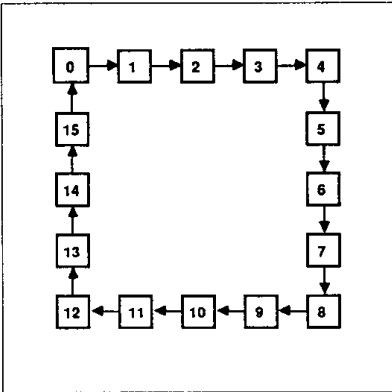

TIMING DIAGRAM

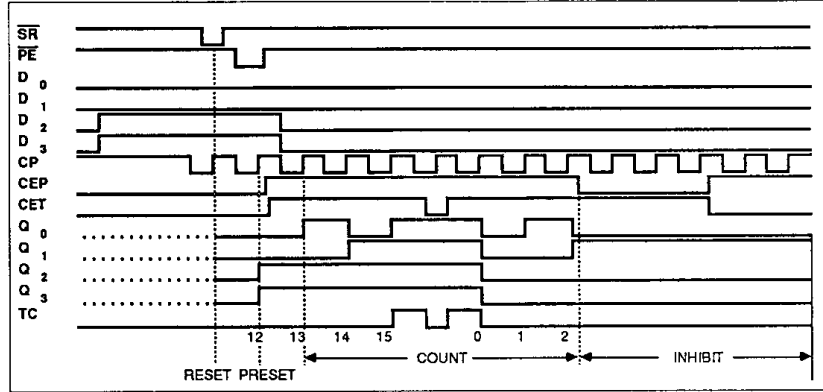

LOGIC DIAGRAM

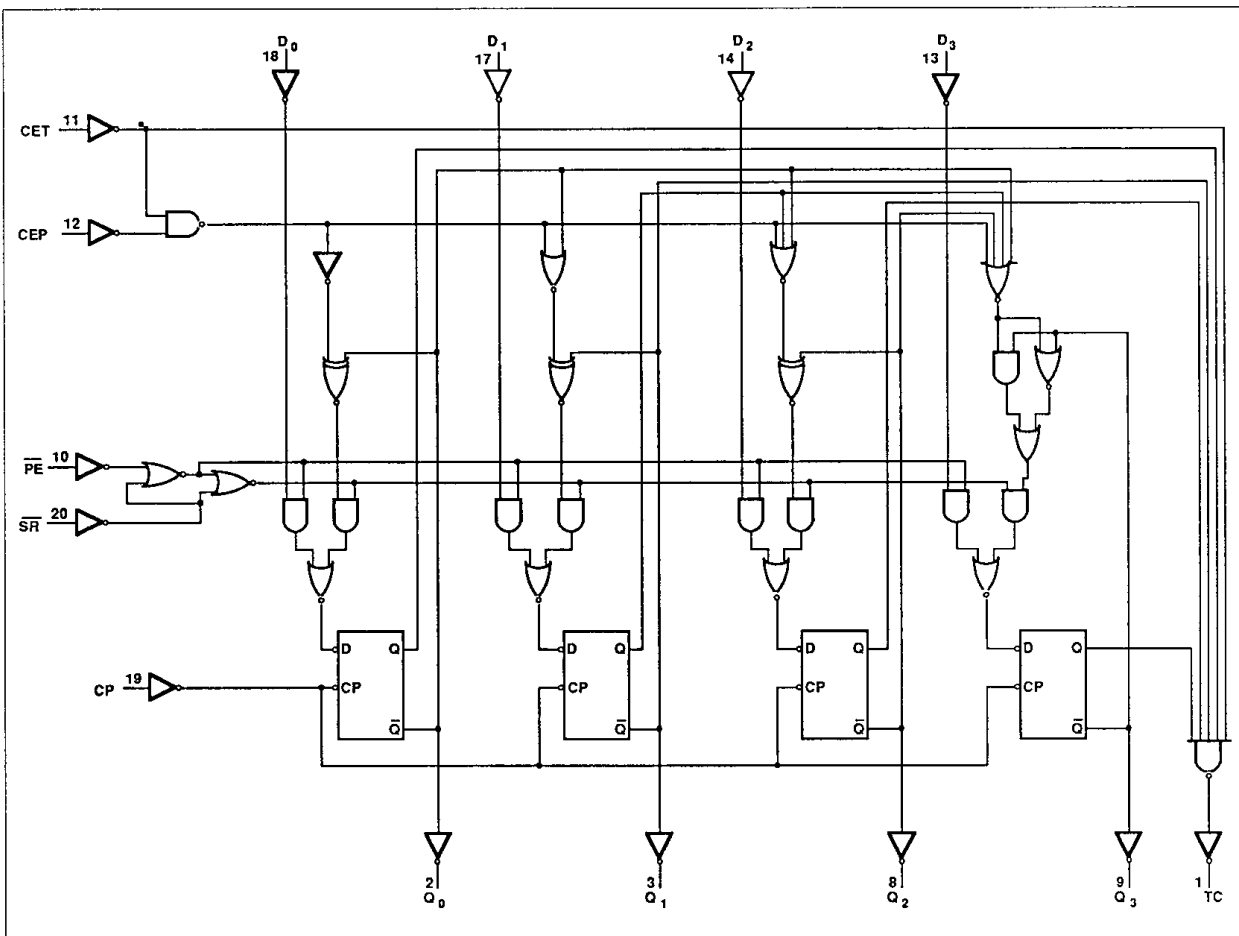

## Synchronous presettable 4-bit binary counter, synchronous reset

74AC/ACT11163

### RECOMMENDED OPERATING CONDITIONS

SYMBOL	PARAMETER	ACT11163			ACT11163			UNIT
		Min	Nom	Max	Min	Nom	Max	
$V_{CC}$	DC supply voltage	3.0 <sup>1</sup>	5.0	5.5	4.5	5.0	5.5	V
$V_I$	Input voltage	0		$V_{CC}$	0		$V_{CC}$	V
$V_O$	Output voltage	0		$V_{CC}$	0		$V_{CC}$	V
$\Delta V/\Delta t$	Input transition rise or fall rate	0		10	0		10	ns/V
$T_{amb}$	Operating free-air temperature range	-40		+85	-40		+85	°C

**NOTE:**

1. No electrical or switching characteristics are specified at  $V_{CC} < 3V$ . Operation between 2V and 3V is not recommended, but within that range, a device output will maintain a previously established logic state.

### ABSOLUTE MAXIMUM RATINGS<sup>1</sup>

SYMBOL	PARAMETER	TEST CONDITIONS	RATING	UNIT
$V_{CC}$	DC supply voltage		-0.5 TO +7.0	V
$I_{IK}$ or $V_I$	DC input diode current <sup>2</sup>	$V_I < 0$	-20	mA
		$V_I > V_{CC}$	20	
	DC input voltage		-0.5 to $V_{CC} + 0.5$	V
$I_{OK}$ or $V_O$	DC output diode current <sup>2</sup>	$V_O < 0$	-50	mA
		$V_O > V_{CC}$	50	
	DC output voltage		-0.5 to $V_{CC} + 0.5$	V
$I_O$	DC output source or sink current per output pin	$V_O = 0$ to $V_{CC}$	±50	mA
$I_{CC}$ or $I_{GND}$	DC $V_{CC}$ current		±125	mA
	DC ground current		±125	
$T_{STG}$	Storage temperature		-65 to 150	°C
$P_{TOT}$	Power dissipation per package	Above 70°C; derate linearly by 8mW/K	500	mW
	Power dissipation per package Plastic surface mount (SO)	Above 70°C; derate linearly by 8mW/K	400	mW

**NOTES:**

1. Stresses beyond those listed may cause permanent damage to the device. These are stress ratings only and functional operation of the device at these or any other conditions beyond those indicated under "recommended operating conditions" is not implied. Exposure to absolute-maximum-rated conditions for extended periods may affect device reliability.
2. The input and output voltage ratings may be exceeded if the input and output current ratings are observed.

# Synchronous presettable 4-bit binary counter, synchronous reset

## 74AC/ACT11163

### DC ELECTRICAL CHARACTERISTICS

SYMBOL	PARAMETER	TEST CONDITIONS	V <sub>CC</sub> V	74AC11163				74ACT11163				UNIT	
				T <sub>amb</sub> = +25°C		T <sub>amb</sub> = -40°C to +85°C		T <sub>amb</sub> = +25°C		T <sub>amb</sub> = -40°C to +85°C			
				Min	Max	Min	Max	Min	Max	Min	Max		
V <sub>IH</sub>	High-level input voltage		3.0	2.10		2.10					V		
			4.5	3.15		3.15		2.0		2.0			
			5.5	3.85		3.85		2.0		2.0			
V <sub>IL</sub>	Low-level input voltage		3.0		0.90		0.90				V		
			4.5		1.35		1.35		0.8			0.8	
			5.5		1.65		1.65		0.8			0.8	
V <sub>OH</sub>	High-level output voltage	V <sub>I</sub> = V <sub>IL</sub> or V <sub>IH</sub>	I <sub>OH</sub> = -50μA	3.0	2.9		2.9				V		
				4.5	4.4		4.4		4.4			4.4	
				5.5	5.4		5.4		5.4			5.4	
			I <sub>OH</sub> = -4mA	3.0	2.58		2.48						
				4.5	3.94		3.8		3.94			3.8	
				5.5	4.94		4.8		4.94			4.8	
I <sub>OH</sub> = -75mA <sup>1</sup>	5.5			3.85				3.85					
V <sub>OL</sub>	Low-level output voltage	V <sub>I</sub> = V <sub>IL</sub> or V <sub>IH</sub>	I <sub>OL</sub> = 50μA	3.0		0.1		0.1			V		
				4.5		0.1		0.1		0.1			0.1
				5.5		0.1		0.1		0.1			0.1
			I <sub>OL</sub> = 12mA	3.0		0.36		0.44					
				4.5		0.36		0.44		0.36			0.44
			I <sub>OL</sub> = 24mA	5.5		0.36		0.44		0.36			0.44
			I <sub>OL</sub> = 75mA <sup>1</sup>	5.5				1.65					1.65
I <sub>I</sub>	Input leakage current	V <sub>I</sub> = V <sub>CC</sub> or GND	5.5		±0.1		±1.0		±0.1		±1.0	μA	
I <sub>CC</sub>	Quiescent supply current	V <sub>I</sub> = V <sub>CC</sub> or GND, I <sub>O</sub> = 0mA	5.5		8.0		80		8.0		80	μA	
ΔI <sub>CC</sub>	Supply current, TTL inputs High <sup>2</sup>	One input at 3.4V, other inputs at V <sub>CC</sub> or GND	5.5						0.9		1.0	mA	

#### NOTES:

- Not more than one output should be tested at a time, and the duration of the test should not exceed 10ms.
- This is the increase in supply current for each input that is at one of the specified TTL voltage levels rather than 0V or V<sub>CC</sub>.

**Synchronous presettable 4-bit binary counter,  
synchronous reset**
**74AC/ACT11163**
**AC ELECTRICAL CHARACTERISTICS AT 3.3V ±0.3V**

SYMBOL	PARAMETER	WAVEFORM	74AC11163					UNIT
			T <sub>amb</sub> = +25°C			T <sub>amb</sub> = -40°C to +85°C		
			Min	Typ	Max	Min	Max	
f <sub>MAX</sub>	Maximum clock frequency	1	90	115		90		MHz
t <sub>PLH</sub> t <sub>PHL</sub>	Propagation delay CP to Q <sub>n</sub> ( $\overline{PE} = "H"$ )	1	2.5 2.9	7.9 8.6	10.5 11.0	2.5 2.9	11.7 12.3	ns
t <sub>PLH</sub> t <sub>PHL</sub>	Propagation delay CP to Q <sub>n</sub> ( $\overline{PE} = "L"$ )	1	2.6 2.9	7.7 8.4	10.2 10.8	2.6 2.9	11.4 12.1	ns
t <sub>PLH</sub> t <sub>PHL</sub>	Propagation delay CP to TC	1	4.0 4.8	10.2 11.3	13.7 13.8	4.0 4.8	15.1 15.5	ns
t <sub>PLH</sub> t <sub>PHL</sub>	Propagation delay CET to TC	2	1.8 2.3	5.7 6.0	7.5 7.7	1.8 2.3	8.2 8.5	ns
t <sub>S</sub>	Setup time, High or Low D <sub>n</sub> to CP	3	5.0			5.0		ns
t <sub>H</sub>	Hold time, High or Low D <sub>n</sub> to CP	3	0.0			0.0		ns
t <sub>S</sub>	Setup time, High or Low $\overline{PE}$ to CP	3	6.5			6.5		ns
t <sub>H</sub>	Hold time, High or Low $\overline{PE}$ to CP	3	0.0			0.0		ns
t <sub>S</sub>	Setup time, High or Low CEP or CET to CP	4	6.0			6.0		ns
t <sub>H</sub>	Hold time, High or Low CEP or CET to CP	4	0.0			0.0		ns
t <sub>W</sub>	Clock pulse width (load) High or Low	1	5.6			5.6		ns
t <sub>W</sub>	Clock pulse width (count) High or Low	1	4.0			4.0		ns
t <sub>S</sub>	Setup time, High or Low $\overline{SR}$ to CP	3	6.0			6.0		ns
t <sub>H</sub>	Hold time, High or Low $\overline{SR}$ to CP	3	0.0			0.0		ns

## Synchronous presettable 4-bit binary counter, synchronous reset

74AC/ACT11163

### AC ELECTRICAL CHARACTERISTICS AT 5.0V ±0.5V

SYMBOL	PARAMETER	WAVEFORM	74AC11163					UNIT
			T <sub>amb</sub> = +25°C			T <sub>amb</sub> = -40°C to +85°C		
			Min	Typ	Max	Min	Max	
f <sub>MAX</sub>	Maximum clock frequency	1	125	170		125		MHz
t <sub>PLH</sub> t <sub>PHL</sub>	Propagation delay CP to Q <sub>n</sub> ( $\overline{PE} = "H"$ )	1	1.9 2.3	5.0 5.7	7.3 8.1	1.9 2.3	8.1 9.0	ns
t <sub>PLH</sub> t <sub>PHL</sub>	Propagation delay CP to Q <sub>n</sub> ( $\overline{PE} = "L"$ )	1	1.9 2.4	4.8 5.5	7.1 7.9	1.9 2.4	7.8 8.9	ns
t <sub>PLH</sub> t <sub>PHL</sub>	Propagation delay CP to TC	1	3.2 4.0	7.2 7.4	9.7 10.3	3.2 4.0	10.6 11.6	ns
t <sub>PLH</sub> t <sub>PHL</sub>	Propagation delay CET to TC	2	1.4 1.9	3.5 4.3	5.3 6.0	1.4 1.9	5.8 6.6	ns
t <sub>s</sub>	Setup time, High or Low D <sub>n</sub> to CP	3	3.5			3.5		ns
t <sub>H</sub>	Hold time, High or Low D <sub>n</sub> to CP	3	0.5			0.5		ns
t <sub>s</sub>	Setup time, High or Low $\overline{PE}$ to CP	3	4.5			4.5		ns
t <sub>H</sub>	Hold time, High or Low $\overline{PE}$ to CP	3	0.0			0.0		ns
t <sub>s</sub>	Setup time, High or Low CEP or CET to CP	4	4.0			4.0		ns
t <sub>H</sub>	Hold time, High or Low CEP or CET to CP	4	0.5			0.5		ns
t <sub>w</sub>	Clock pulse width (load) High or Low	1	4.0			4.0		ns
t <sub>w</sub>	Clock pulse width (count) High or Low	1	4.0			4.0		ns
t <sub>s</sub>	Setup time, High or Low SR to CP	3	4.5			4.5		ns
t <sub>H</sub>	Hold time, High or Low SR to CP	3	0.0			0.0		ns

**Synchronous presettable 4-bit binary counter,  
synchronous reset**
**74AC/ACT11163**
**AC ELECTRICAL CHARACTERISTICS AT 5.0V ±0.5V**

SYMBOL	PARAMETER	WAVEFORM	74ACT11163					UNIT
			T <sub>amb</sub> = +25°C			T <sub>amb</sub> = -40°C to +85°C		
			Min	Typ	Max	Min	Max	
f <sub>MAX</sub>	Maximum clock frequency	1	120	155		120		MHz
t <sub>PLH</sub> t <sub>PHL</sub>	Propagation delay CP to Q <sub>n</sub> (PE = "H")	1	2.8 3.2	5.5 6.2	7.6 8.5	2.8 3.2	8.4 9.4	ns
t <sub>PLH</sub> t <sub>PHL</sub>	Propagation delay CP to Q <sub>n</sub> (PE = "L")	1	2.7 3.2	5.4 6.1	7.3 8.3	2.7 3.2	8.1 9.3	ns
t <sub>PLH</sub> t <sub>PHL</sub>	Propagation delay CP to TC	1	3.6 4.6	6.5 7.8	8.6 10.3	3.6 4.6	9.6 11.6	ns
t <sub>PLH</sub> t <sub>PHL</sub>	Propagation delay CET to TC	2	2.0 3.0	3.9 6.2	5.4 9.1	2.0 3.0	6.0 10.1	ns
t <sub>S</sub>	Setup time, High or Low D <sub>n</sub> to CP	3	5.0			5.0		ns
t <sub>H</sub>	Hold time, High or Low D <sub>n</sub> to CP	3	0.5			0.5		ns
t <sub>S</sub>	Setup time, High or Low PE to CP	3	6.0			6.0		ns
t <sub>H</sub>	Hold time, High or Low PE to CP	3	0.5			0.5		ns
t <sub>S</sub>	Setup time, High or Low CEP or CET to CP	4	6.5			6.5		ns
t <sub>H</sub>	Hold time, High or Low CEP or CET to CP	4	0.5			0.5		ns
t <sub>W</sub>	Clock pulse width (load) High or Low	1	4.2			4.2		ns
t <sub>W</sub>	Clock pulse width (count) High or Low	1	4.0			4.0		ns
t <sub>S</sub>	Setup time, High or Low SR to CP	3	7.0			7.0		ns
t <sub>H</sub>	Hold time, High or Low SR to CP	3	0.5			0.5		ns



# Synchronous presettable 4-bit binary counter, synchronous reset

74AC/ACT11163

## AC WAVEFORMS

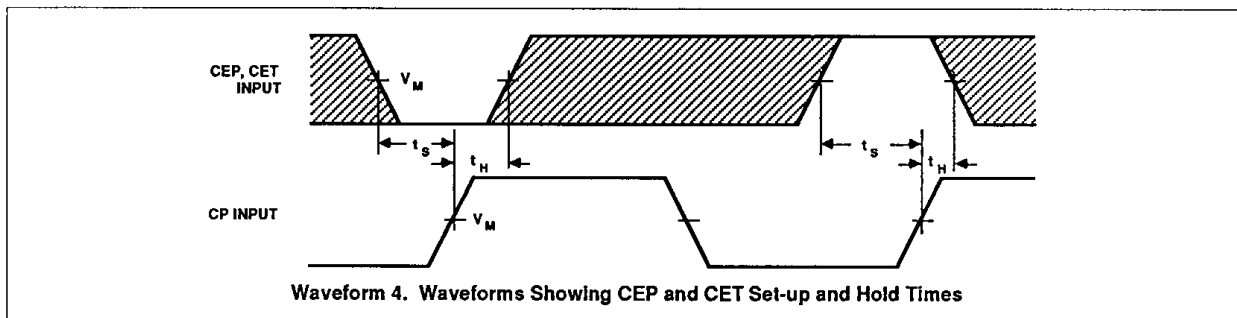
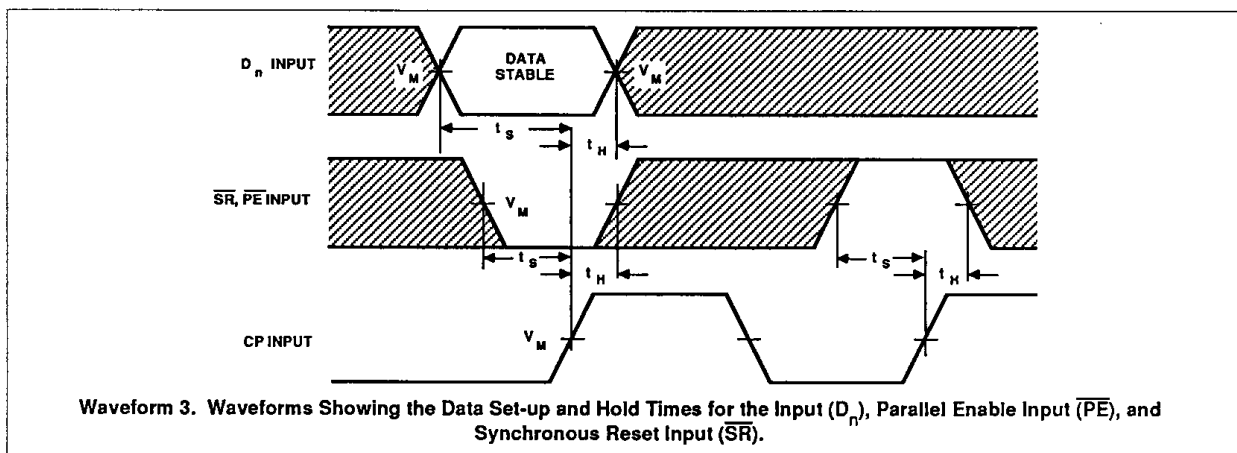
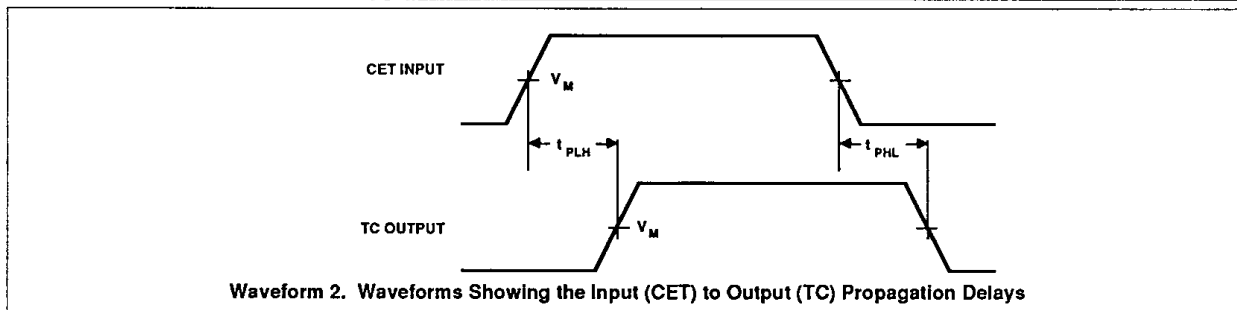
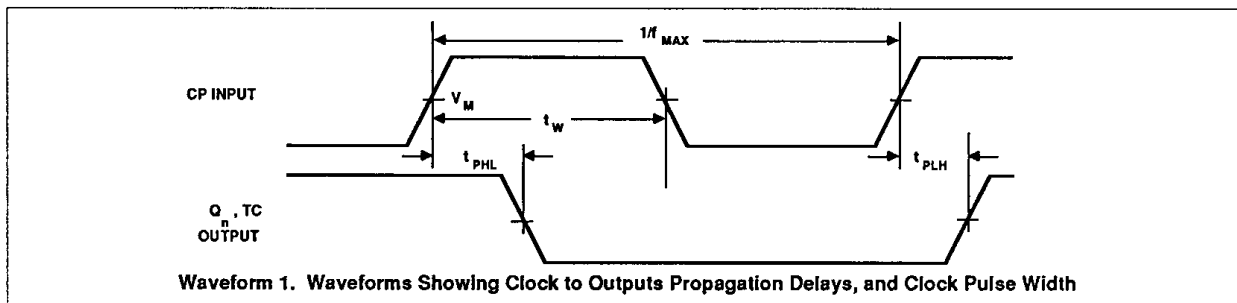

**Synchronous presettable 4-bit binary counter,  
synchronous reset**

**74AC/ACT11163**

**WAVEFORM CONDITIONS**

	INPUTS	OUTPUTS
AC	$V_{IN} = \text{GND to } V_{CC},$ $V_M = 50\% V_{CC}$	$V_{OUT} = V_{OL} \text{ to } V_{OH}$
ACT	$V_{IN} = \text{GND to } 3.0V,$ $V_M = 1.5V$	$V_M = 50\% V_{CC}$

**TEST CIRCUIT**

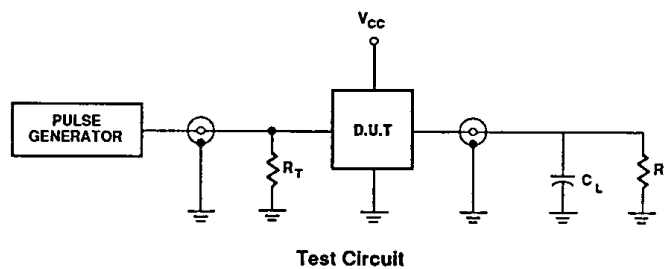

**DEFINITIONS**

- $C_L$  = Load capacitance, 50pF; includes jig and probe capacitance
- $R_L$  = Load resistor, 500Ω
- $R_T$  = Termination resistance should be equal to  $Z_{OUT}$  of pulse generators
- Input pulses:  $PRR \leq 10\text{MHz}$   
 $t_r = t_f = 3\text{ns}$