

Document No.	853-1509
ECN No.	00730
Date of Issue	October 17, 1990
Status	Product Specification
ACL Products	

74AC/ACT11162

Synchronous presettable BCD decade counter, synchronous reset

FEATURES

- Synchronous counting and loading
- Two count enable inputs for n-bit cascading
- Positive edge-triggered clock
- Synchronous reset
- Output capability: $\pm 24\text{mA}$
- CMOS (AC) and TTL (ACT) voltage level inputs
- 50Ω incident wave switching
- Center-pin V_{CC} and ground configuration to minimize high-speed switching noise
- I_{CC} category: MSI

DESCRIPTION

The 74AC/ACT11162 high-performance CMOS devices combine very high speed and high output drive comparable to the most advanced TTL families.

The 74AC/ACT11162 4-bit synchronous presettable decade counters feature an internal carry look-ahead and can be used for high-speed counting. Synchronous operation is provided by having all flip-flops clocked simultaneously on the positive-going edge of the clock.

QUICK REFERENCE DATA

SYMBOL	PARAMETER	CONDITIONS $T_{amb} = 25^\circ\text{C}; \text{GND} = 0\text{V};$ $V_{CC} = 5.0\text{V}$	TYPICAL		UNIT
			AC	ACT	
t_{PLH}/t_{PHL}	Propagation delay C_{P_n} to Q_n ($\overline{PE} = \text{High}$)	$C_L = 50\text{pF}$	6.9	6.2	ns
C_{PD}	Power dissipation capacitance ¹	$f = 1\text{MHz}; C_L = 50\text{pF}$	54	58	pF
C_{IN}	Input capacitance	$V_I = 0\text{V}$ or V_{CC}	4.0	4.0	pF
I_{LATCH}	Latch-up current	Per Jedec JC40.2 Standard 17	500	500	mA
f_{MAX}	Maximum clock frequency	$C_L = 50\text{pF}$	140	150	MHz

Note:

1. C_{PD} is used to determine the dynamic power dissipation (P_D in μW):

$$P_D = C_{PD} \times V_{CC}^2 \times f_I + \sum (C_L \times V_{CC}^2 \times f_O) \text{ where:}$$

f_I = input frequency in MHz, C_L = output load capacitance in pF,

f_O = output frequency in MHz, V_{CC} = supply voltage in V,

$\sum (C_L \times V_{CC}^2 \times f_O)$ = sum of outputs

ORDERING INFORMATION

PACKAGES	TEMPERATURE RANGE	ORDER CODE
20-pin plastic DIP (300mil-wide)	-40°C to +85°C	74AC11162N 74ACT11162N
20-pin plastic SOL (300mil-wide)	-40°C to +85°C	74AC11162D 74ACT11162D

PIN CONFIGURATION

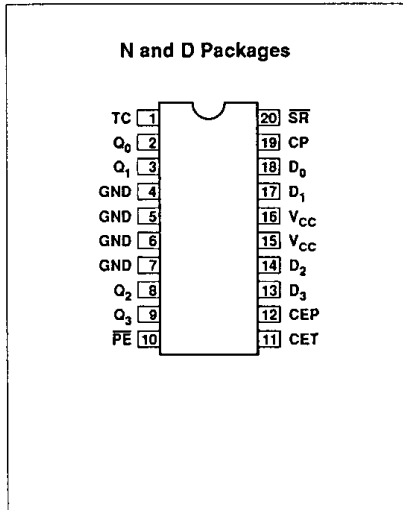

LOGIC SYMBOL

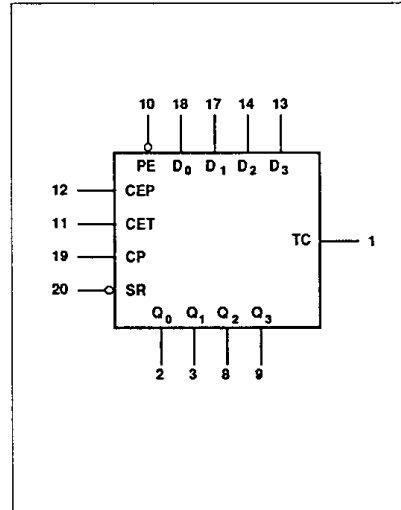

LOGIC SYMBOL (IEEE/IEC)

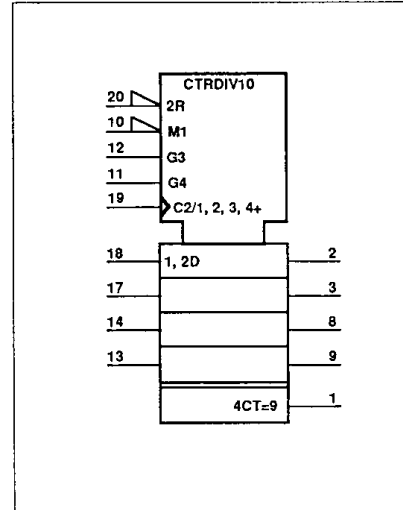

Synchronous presettable BCD decade counter, synchronous reset

74AC/ACT11162

The outputs of the counters may be preset to High or Low levels. A Low level at the Parallel Enable (\overline{PE}) input disables the counting action and causes the data at the $D_0 - D_3$ inputs to be loaded into the counter on the rising edge of the clock. Preset takes place regardless of the levels at Count Enable (CEP, CET) inputs.

A Low level at the Reset (\overline{SR}) input sets all four outputs of the flip-flops ($Q_0 - Q_3$) to Low levels after the next positive-going transition on the clock (CP) input. This action occurs regardless of the levels at \overline{PE} , CET, and CEP inputs. This synchronous reset feature enables the designer to modify the maximum count with only one external NAND gate.

The carry look-ahead simplifies serial cascading of the counters. Both Count Enable inputs (CEP and CET) must be High to count. The CET input is fed forward to enable the Terminal Count (TC) output. The TC output thus enabled will produce a High output pulse of a duration approximately equal to the High level output of Q_0 . This pulse can be used to enable the next cascaded stage.

PIN DESCRIPTION

PIN NUMBER	SYMBOL	NAME AND FUNCTION
20	\overline{SR}	Synchronous reset (active Low)
19	CP	Clock input (Low-to-High edge-triggered)
18, 17, 14, 13	$D_0 - D_3$	Data inputs
12	CEP	Count enable input
10	\overline{PE}	Parallel enable input (active Low)
11	CET	Count enable carry input
18, 17, 14, 13	$Q_0 - Q_3$	Counter outputs
1	TC	Terminal count output
4, 5, 6, 7	GND	Ground (0V)
15, 16	V_{CC}	Positive supply voltage

FUNCTION TABLE

OPERATING MODE	INPUTS						OUTPUTS	
	\overline{SR}	CP	CEP	CET	\overline{PE}	D_n	Q_n	TC
Reset (clear)	l	↑	X	X	X	X	L	L
Parallel load	h	↑	X	X	l	l	L	L
	h	↑	X	X	l	h	H	(1)
Count	h	↑	h	h	h	X	count	(1)
Hold (do nothing)	h	X	l	X	h	X	q_n	(1)
	h	X	X	l	h	X	q_n	L

H = High voltage level

L = Low voltage level

h = High voltage level one setup time prior to the Low-to-High clock transition

l = Low voltage level one setup time prior to the Low-to-High clock transition

X = Don't care

q = State of the referenced output prior to the Low-to-High clock transition

↑ = Low-to-High clock transition

NOTE:

- The TC output is High when CET is High and the counter is at Terminal Count (HLLH).

Synchronous presettable BCD decade counter, synchronous reset

74AC/ACT11162

STATE DIAGRAM

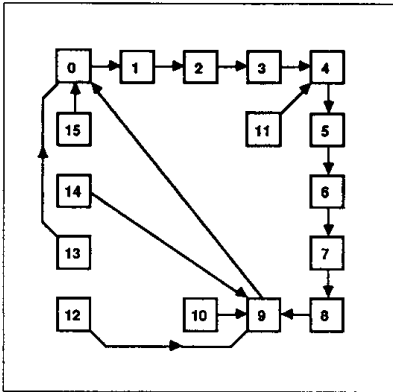

TIMING DIAGRAM

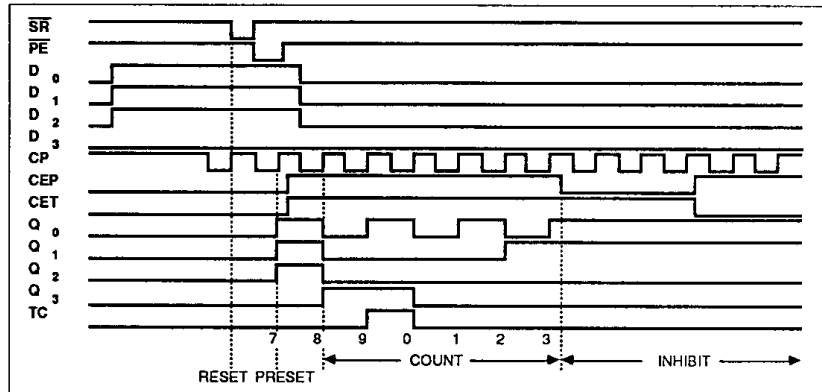

LOGIC DIAGRAM

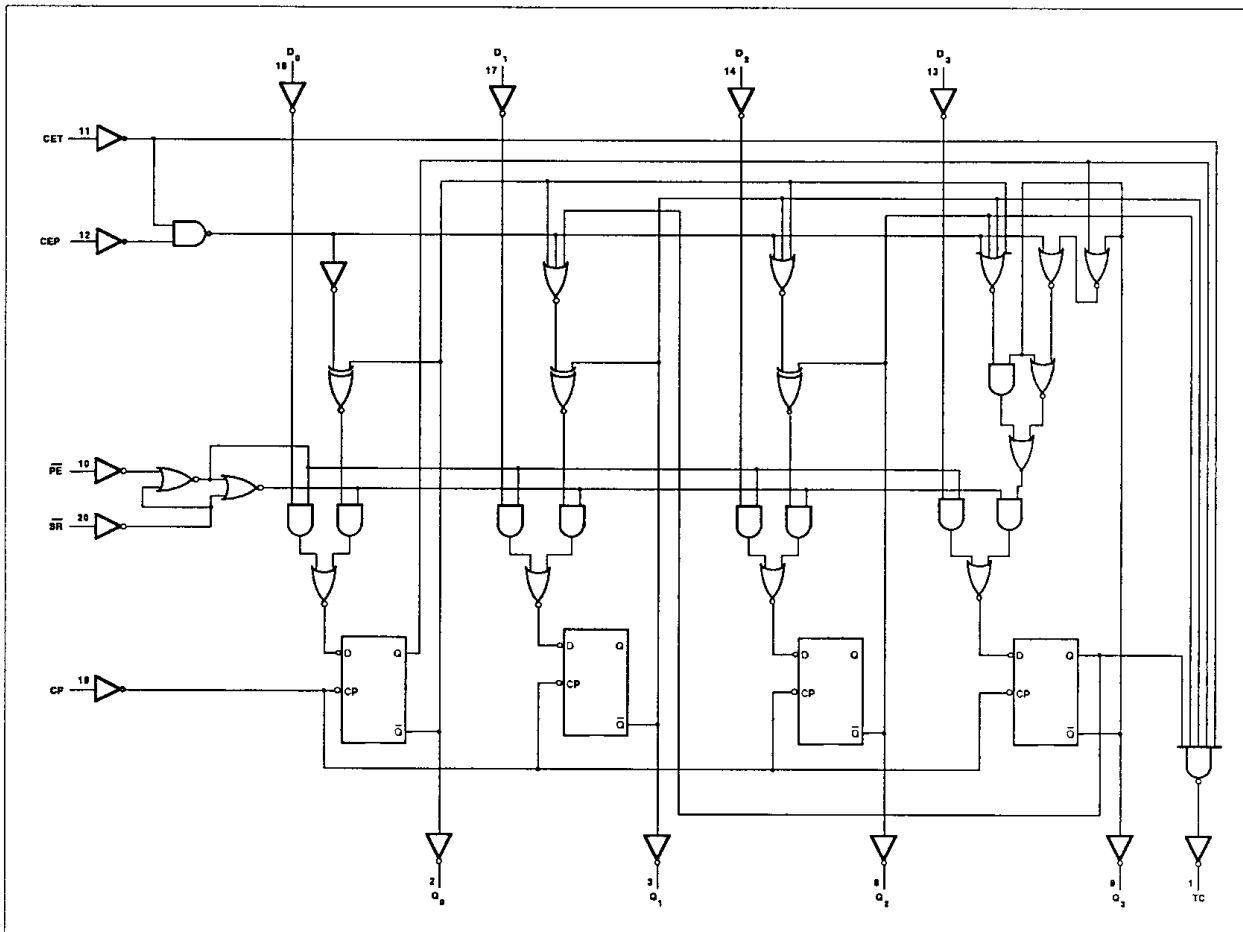

Synchronous presettable BCD decade counter, synchronous reset

74AC/ACT11162

RECOMMENDED OPERATING CONDITIONS

SYMBOL	PARAMETER	74AC11162			74ACT11162			UNIT
		Min	Nom	Max	Min	Nom	Max	
V_{CC}	DC supply voltage	3.0 ¹	5.0	5.5	4.5	5.0	5.5	V
V_I	Input voltage	0		V_{CC}	0		V_{CC}	V
V_O	Output voltage	0		V_{CC}	0		V_{CC}	V
$\Delta t/\Delta v$	Input transition rise or fall rate	0		10	0		10	ns/V
T_{amb}	Operating free-air temperature range	-40		+85	-40		+85	°C

NOTE:

1. No electrical or switching characteristics are specified at $V_{CC} < 3V$. Operation between 2V and 3V is not recommended, but within that range, a device output will maintain a previously established logic state.

ABSOLUTE MAXIMUM RATINGS¹

SYMBOL	PARAMETER	TEST CONDITIONS	RATING	UNIT
V_{CC}	DC supply voltage		-0.5 TO +7.0	V
I_{IK} or V_I	DC input diode current ²	$V_I < 0$	-20	mA
		$V_I > V_{CC}$	20	
	DC input voltage		-0.5 to $V_{CC} + 0.5$	V
I_{OK} or V_O	DC output diode current ²	$V_O < 0$	-50	mA
		$V_O > V_{CC}$	50	
	DC output voltage		-0.5 to $V_{CC} + 0.5$	V
I_O	DC output source or sink current per output pin	$V_O = 0$ to V_{CC}	±50	mA
I_{CC} or I_{GND}	DC V_{CC} current		±125	mA
	DC ground current		±125	
T_{STG}	Storage temperature		-65 to 150	°C
P_{TOT}	Power dissipation per package	Above 70°C; derate linearly by 8mW/K	500	mW
	Power dissipation per package Plastic surface mount (SO)	Above 70°C; derate linearly by 8mW/K	400	mW

NOTES:

1. Stresses beyond those listed may cause permanent damage to the device. These are stress ratings only and functional operation of the device at these or any other conditions beyond those indicated under "recommended operating conditions" is not implied. Exposure to absolute-maximum-rated conditions for extended periods may affect device reliability.
2. The input and output voltage ratings may be exceeded if the input and output current ratings are observed.

Synchronous presettable BCD decade counter, synchronous reset

74AC/ACT11162

DC ELECTRICAL CHARACTERISTICS

SYMBOL	PARAMETER	TEST CONDITIONS	V _{CC}	74AC11162				74ACT11162				UNIT	
				T _{amb} = +25°C		T _{amb} = -40°C to +85°C		T _{amb} = +25°C		T _{amb} = -40°C to +85°C			
				Min	Max	Min	Max	Min	Max	Min	Max		
V _{IH}	High-level input voltage		3.0	2.10		2.10						V	
			4.5	3.15		3.15		2.0		2.0			
			5.5	3.85		3.85		2.0		2.0			
V _{IL}	Low-level input voltage		3.0		0.90		0.90					V	
			4.5		1.35		1.35		0.8		0.8		
			5.5		1.65		1.65		0.8		0.8		
V _{OH}	High-level output voltage	V _I = V _{IL} or V _{IH}	I _{OH} = -50μA	3.0	2.9		2.9					V	
				4.5	4.4		4.4		4.4		4.4		
				5.5	5.4		5.4		5.4		5.4		
			I _{OH} = -4mA	3.0	2.58		2.48						
				4.5	3.94		3.8		3.94		3.8		
				5.5	4.94		4.8		4.94		4.8		
I _{OH} = -75mA ¹	5.5			3.85				3.85					
V _{OL}	Low-level output voltage	V _I = V _{IL} or V _{IH}	I _{OL} = 50μA	3.0		0.1		0.1				V	
				4.5		0.1		0.1		0.1			0.1
				5.5		0.1		0.1		0.1			0.1
			I _{OL} = 12mA	3.0		0.36		0.44					
				4.5		0.36		0.44		0.36			0.44
				5.5		0.36		0.44		0.36			0.44
I _{OL} = 75mA ¹	5.5				1.65				1.65				
I _I	Input leakage current	V _I = V _{CC} or GND	5.5		±0.1		±1.0		±0.1		±1.0	μA	
I _{CC}	Quiescent supply current	V _I = V _{CC} or GND, I _O = 0mA	5.5		8.0		80		8.0		80	μA	
ΔI _{CC}	Supply current, TTL inputs High ²	One input at 3.4V, other inputs at V _{CC} or GND	5.5						0.9		1.0	mA	

NOTES:

- Not more than one output should be tested at a time, and the duration of the test should not exceed 10ms.
- This is the increase in supply current for each input that is at one of the specified TTL voltage levels rather than 0V or V_{CC}.

**Synchronous presettable BCD decade counter,
synchronous reset**
74AC/ACT11162
AC ELECTRICAL CHARACTERISTICS AT 3.3V ±0.3V

SYMBOL	PARAMETER	WAVEFORM	74AC11162					UNIT
			T _{amb} = +25°C			T _{amb} = -40°C to +85°C		
			Min	Typ	Max	Min	Max	
f _{MAX}	Maximum clock frequency	1	66	90		66		MHz
t _{PLH} t _{PHL}	Propagation delay CP to Q _n (\overline{PE} = "H")	1	1.5 1.5	8.7 10.2	11.7 14.4	1.5 1.5	13.2 16.0	ns
t _{PLH} t _{PHL}	Propagation delay CP to Q _n (\overline{PE} = "L")	1	1.5 1.5	8.7 10.4	11.2 14.1	1.5 1.5	12.6 16.0	ns
t _{PLH} t _{PHL}	Propagation delay CP to TC	1	1.5 1.5	10.5 12.1	14.1 15.8	1.5 1.5	15.9 18.0	ns
t _{PLH} t _{PHL}	Propagation delay CET to TC	2	1.5 1.5	5.8 6.9	7.6 9.9	1.5 1.5	8.5 11.0	ns
t _S	Setup time, High or Low D _n to CP	3	6.0			6.0		ns
t _H	Hold time, High or Low D _n to CP	3	1.0			1.0		ns
t _S	Setup time, High or Low \overline{PE} to CP	3	6.0			6.0		ns
t _H	Hold time, High or Low \overline{PE} to CP	3	1.0			1.0		ns
t _S	Setup time, High or Low CEP or CET to CP	4	7.5			7.5		ns
t _H	Hold time, High or Low CEP or CET to CP	4	1.0			1.0		ns
t _W	Clock pulse width (load) High or Low	1	7.5			7.5		ns
t _W	Clock pulse width (count) High or Low	1	7.5			7.5		ns
t _S	Setup time, High or Low \overline{SR} to CP	3	7.5			7.5		ns
t _H	Hold time, High or Low \overline{SR} to CP	3	1.0			1.0		ns

Synchronous presettable BCD decade counter, synchronous reset

74AC/ACT11162

AC ELECTRICAL CHARACTERISTICS AT 5.0V ±0.5V

SYMBOL	PARAMETER	WAVEFORM	74AC11162					UNIT
			T _{amb} = +25°C			T _{amb} = -40°C to +85°C		
			Min	Typ	Max	Min	Max	
f _{MAX}	Maximum clock frequency	1	110	140		110		MHz
t _{PLH} t _{PHL}	Propagation delay CP to Q _n (\overline{PE} = "H")	1	1.5 1.5	6.4 7.4	8.4 10.5	1.5 1.5	9.5 11.9	ns
t _{PLH} t _{PHL}	Propagation delay CP to Q _n (\overline{PE} = "L")	1	1.5 1.5	6.0 7.2	7.9 10.1	1.5 1.5	9.0 11.5	ns
t _{PLH} t _{PHL}	Propagation delay CP to TC	1	1.5 1.5	7.7 8.3	10.1 11.1	1.5 1.5	11.2 12.6	ns
t _{PLH} t _{PHL}	Propagation delay CET to TC	2	1.5 1.5	4.0 5.0	5.5 7.4	1.5 1.5	6.0 10.2	ns
t _S	Setup time, High or Low D _n to CP	3	4.0			4.0		ns
t _H	Hold time, High or Low D _n to CP	3	1.0			1.0		ns
t _S	Setup time, High or Low \overline{PE} to CP	3	5.0			5.0		ns
t _H	Hold time, High or Low \overline{PE} to CP	3	1.0			1.0		ns
t _S	Setup time, High or Low CEP or CET to CP	4	6.0			6.0		ns
t _H	Hold time, High or Low CEP or CET to CP	4	1.0			1.0		ns
t _W	Clock pulse width (load) High or Low	1	4.5			4.5		ns
t _W	Clock pulse width (count) High or Low	1	4.5			4.5		ns
t _S	Setup time, High or Low \overline{SR} to CP	3	4.5			4.5		ns
t _H	Hold time, High or Low \overline{SR} to CP	3	1.0			1.0		ns

Synchronous presettable BCD decade counter, synchronous reset

74AC/ACT11162

AC ELECTRICAL CHARACTERISTICS AT 5.0V \pm 0.5V

SYMBOL	PARAMETER	WAVEFORM	74ACT11162					UNIT
			T _{amb} = +25°C			T _{amb} = -40°C to +85°C		
			Min	Typ	Max	Min	Max	
f _{MAX}	Maximum clock frequency	1	125	150		125		MHz
t _{PLH} t _{PHL}	Propagation delay CP to Q _n (\overline{PE} = "H")	1	2.4 2.8	5.7 6.6	9.0 10.2	2.4 2.8	10.0 11.6	ns
t _{PLH} t _{PHL}	Propagation delay CP to Q _n (\overline{PE} = "L")	1	2.3 2.9	5.6 6.6	8.6 10.0	2.3 2.9	9.7 11.4	ns
t _{PLH} t _{PHL}	Propagation delay CP to TC	1	2.6 3.2	6.7 7.9	10.1 11.9	2.6 3.2	11.4 13.5	ns
t _{PLH} t _{PHL}	Propagation delay CET to TC	2	1.2 2.1	4.0 6.3	6.0 10.0	1.2 2.1	6.6 11.3	ns
t _S	Setup time, High or Low D _n to CP	3	5.0			5.0		ns
t _H	Hold time, High or Low D _n to CP	3	1.0			1.0		ns
t _S	Setup time, High or Low \overline{PE} to CP	3	7.0			7.0		ns
t _H	Hold time, High or Low \overline{PE} to CP	3	0.5			0.5		ns
t _S	Setup time, High or Low CEP or CET to CP	4	7.5			7.5		ns
t _H	Hold time, High or Low CEP or CET to CP	4	0.5			0.5		ns
t _w	Clock pulse width (load) High or Low	1	4.0			4.0		ns
t _w	Clock pulse width (count) High or Low	1	4.0			4.0		ns
t _S	Setup time, High or Low \overline{SR} to CP	3	7.5			7.5		ns
t _H	Hold time, High or Low \overline{SR} to CP	3	0.5			0.5		ns

Synchronous presettable BCD decade counter, synchronous reset

74AC/ACT11162

AC WAVEFORMS

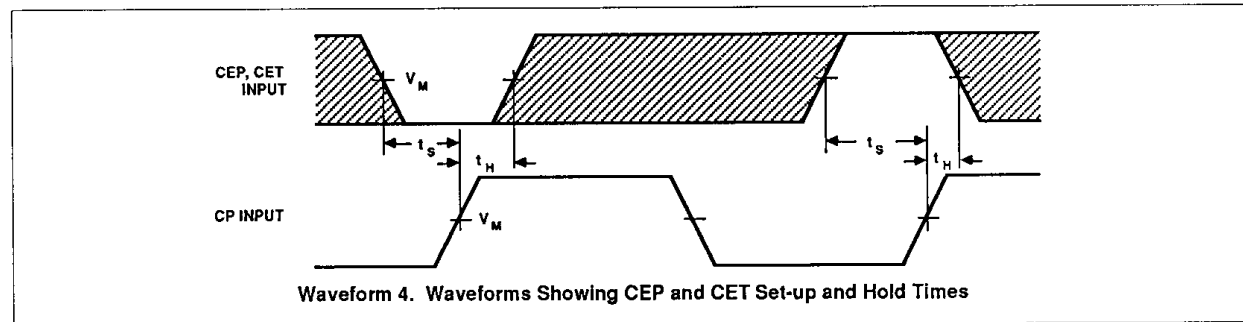
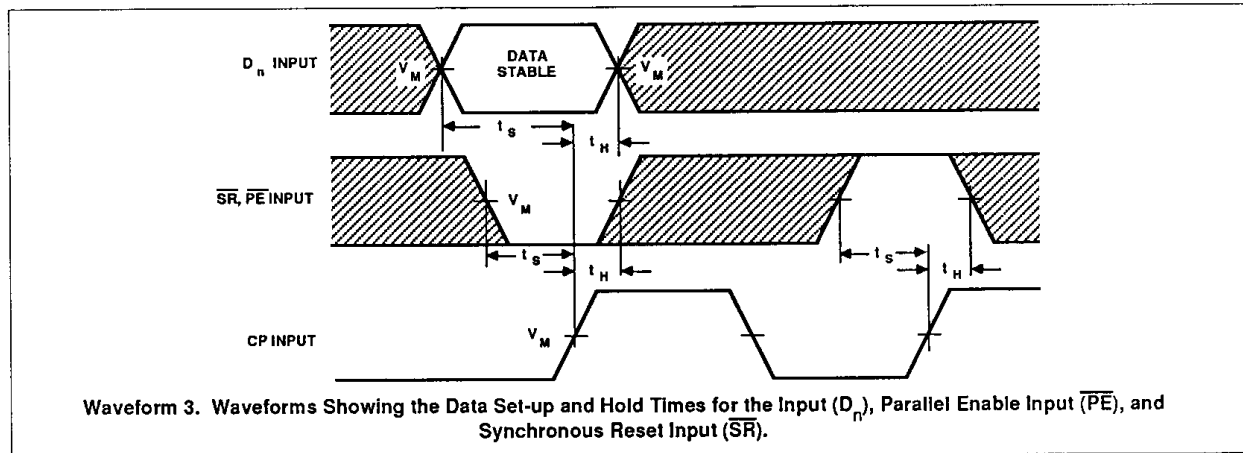
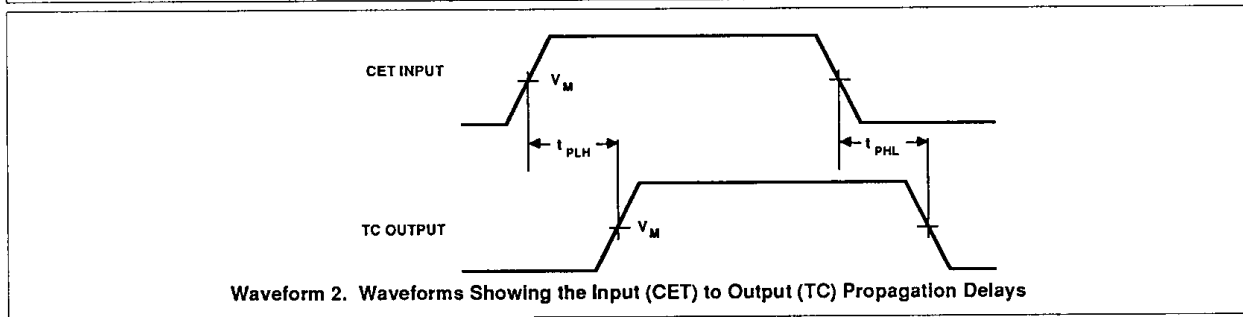
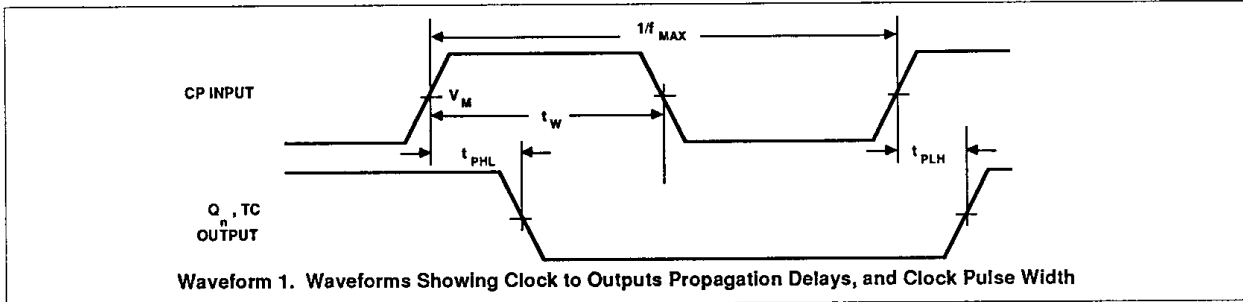

Synchronous presettable BCD decade counter, synchronous reset

74AC/ACT11162

WAVEFORM CONDITIONS

	INPUTS	OUTPUTS
AC	$V_{IN} = \text{GND to } V_{CC},$ $V_M = 50\% V_{CC}$	$V_{OUT} = V_{OL} \text{ to } V_{OH}$ $V_M = 50\% V_{CC}$
ACT	$V_{IN} = \text{GND to } 3.0V,$ $V_M = 1.5V$	

TEST CIRCUIT

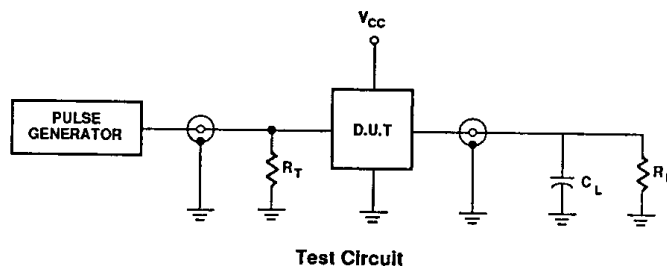

DEFINITIONS

- C_L = Load capacitance, 50pF; includes jig and probe capacitance
- R_L = Load resistor, 500Ω
- R_T = Termination resistance should be equal to Z_{OUT} of pulse generators
- Input pulses: $PRR \leq 10\text{MHz}$
 $t_r = t_f = 3\text{ns}$