

The Small-signal NPN Silicon High Voltage Medium-Power Transistor

DESCRIPTION

The BF620 is an NPN silicon epitaxial transistor designed for application as a video output to drive color CRT, telephony, professional communication equipment and other high voltage applications.

It has dynamic range and good current characteristic.

This high voltage transistor in 3-Pin mini power plastic package SOT89 offers superior quality and performance at low cost.

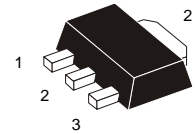

1 – Base
2 – Collector
3 – Emitter

FEATURES

- Low Saturation Voltages
 $V_{CE(sat)} = 0.6\text{ V}$
 $V_{BE(sat)} = 0.9\text{ V}$
- High Breakdown Voltages
 $V_{(BR)CBO} = 300\text{ V}$
 $V_{(BR)CEO} = 300\text{ V}$
- Low Collector Current
 $I_C = 50\text{ mA}$
- Complementary to BF621

	SOT89
JEDEC	TO-243
EIAJ	SC-62
GOST	KT-47
Weight:	0.055g

ABSOLUTE MAXIMUM RATINGS ($T_A = 25\text{ °C}$)

Rating	Symbol	Value	Unit
Collector – Emitter Voltage	V_{CEO}	300	V
Collector – Base Voltage	V_{CBO}	300	V
Emitter – Base Voltage	V_{EBO}	5	V
Collector Current	I_C	50	mA
Peak Collector Current	I_{CM}	100	mA
Collector Dissipation	P_C	1.0	W
Junction Temperature	T_{JMAX}	150	°C
Operating Junction Temperature Range	T_{OPR}	-60 to +100	°C
Storage Temperature Range	T_{STG}	-65 to +150	°C

ORDERING INFORMATION

Device	Marking	Package	Quantity	Packing Style
BF620	DC	SOT-89	5 Kpcs / plastic bags	In bulk
BF620-T1	DC	SOT-89	1 Kpcs / Reel	Embossed tape 12-mm wide 7" dia. Pin 2 (Collector) towards the windung. Perforation on the right.

BF620

ELECTRICAL CHARACTERISTICS ($T_A = 25\text{ }^\circ\text{C}$ unless otherwise noted)

Characteristic	Symbol	Min	Typ	Max	Unit
DC CHARACTERISTICS					
Collector – Base Cutoff Current, $I_E = 0\text{mA}$, $V_{CE} = 200\text{V}$	I_{CBO}	–	–	10	nA
Emitter – Base Cutoff Current, $I_C = 0\text{mA}$, $V_{EB} = 5\text{V}$	I_{EBO}	–	–	50	nA
Collector – Base Breakdown Voltage, $I_C = 10\mu\text{A}$, $I_E = 0\text{mA}$	$V_{(BR)CBO}$	300	–	–	V
Collector – Emitter Breakdown Voltage, $I_C = 1\text{mA}$, $I_B = 0\text{mA}$	$V_{(BR)CEO}$	300	–	–	V
Emitter – Base Breakdown Voltage, $I_E = 100\mu\text{A}$, $I_C = 0\text{mA}$	$V_{(BR)CEO}$	5	–	–	V
DC Current Gain, $I_C = 25\text{mA}$, $V_{CE} = 20\text{V}$	h_{FE}	50	–	–	–

AC CHARACTERISTICS

Collector – Emitter Saturation Voltage, $I_C = 30\text{mA}$, $I_B = 5\text{mA}$	$V_{CE(sat)}$	–	–	0.6	V
Base – Emitter Saturation Voltage, $I_C = 20\text{mA}$, $I_B = 2\text{mA}$	$V_{BE(sat)}$	–	–	0.9	V
Collector – Base Capacitance, $I_E = 0\text{mA}$, $V_{CE} = 30\text{V}$, $f = 1\text{MHz}$	C_{OB}	–	–	1.6	pF
Current Gain – Bandwidth Product, $I_C = 10\text{mA}$, $V_{CE} = 10\text{V}$	f_T	60	–	–	MHz

PACKAGE DIMENSIONS of BF620 in mm

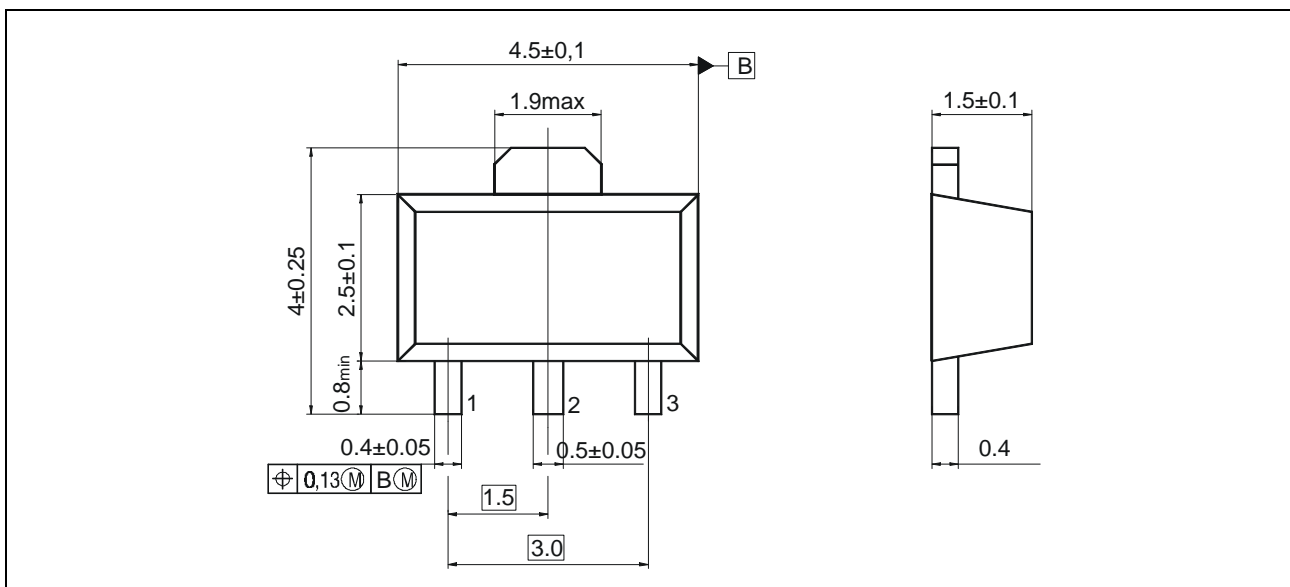

PLASTIC CASE KT-47