

1 Amp Low Dropout Positive Voltage Regulator

The PJ1117 Series of high performance positive voltage regulators are designed for use in applications requiring low dropout performance at full rated current. Additionally, the PJ1117 Series provides excellent regulation over variations due to changes in line, load and temperature. Outstanding features include low dropout performance at rated current, fast transient response. The PJ1117 Series are three terminal regulators with fixed and adjustable voltage options available in popular packages.

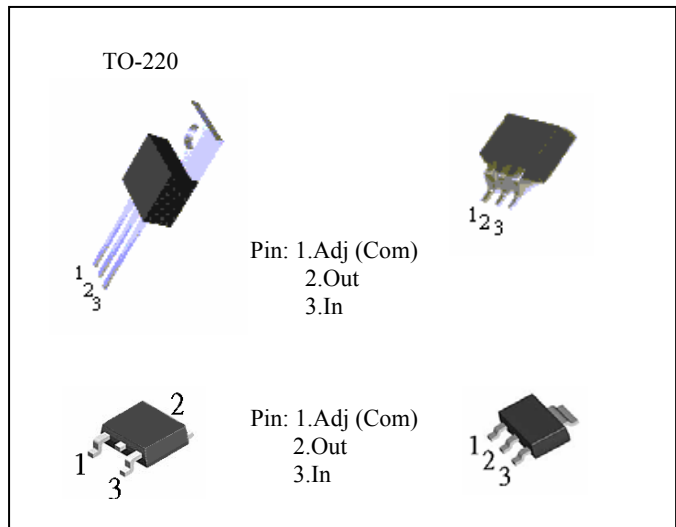

FEATURES

- Low dropout voltage 1.3 V max.
- Full current rating over line and temperature
- Fast transient response
- $\pm 2\%$ Total output regulation over line, load and temperature
- Adjust pin current max 120 μ A over temperature
- Line regulation typical 0.015%.
- Load regulation typical 0.05%.
- Fixed/adjustable output voltage
- TO-220, TO-263, TO-252& SOT-223 package

BLOCK DIAGRAM

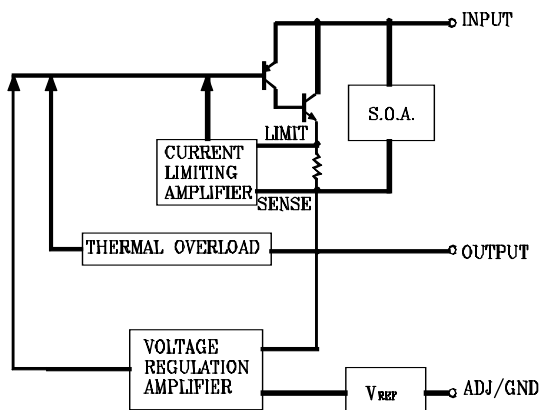

ORDERING INFORMATION

Device	Operating Temperature (Ambient)	Package
PJ1117CZ-adj / 1.8V PJ1117CZ-2.5V / 2.85V PJ1117CZ-3.3V PJ1117CZ-5.0V	-20 to +85°C	TO-220
PJ1117CM -adj / 1.8V PJ1117CM-2.5V / 2.85V PJ1117CM-3.3V PJ1117CM-5.0V		TO-263
PJ1117CW-adj / 1.8V PJ1117CW-2.5V/2.85V PJ1117CW-3.3V PJ1117CW-5.0V		SOT-223
PJ1117CP-adj / 1.8V PJ1117CP-2.5V/2.85V PJ1117CP-3.3V PJ1117CP-5.0V		TO-252

NOTE: Contact factory for additional voltage option.

ABSOLUTE MAXIMUM RATING

Parameter	Symbol	Maximum	Units
Input Voltage	V_{IN}	7	V
Power Dissipation	P_D	Internally Limited	W
Thermal Resistance Junction to Case	θ_{JC}	2.5	°C / W
Thermal Resistance Junction to Ambient	θ_{JA}	50	
Operating Junction Temperature Range	T_J	0 to +125	°C
Operating Ambient Temperature Range	T_A	-20 to +85	
Storage Temperature Range	T_{STG}	-25 to 150	
Lead Temperature (Soldering) 10 Sec.	T_{LEAD}	260	

1 Amp Low Dropout Positive Voltage Regulator

ELECTRICAL CHARACTERISTICS

Unless otherwise specified, Adjust $V_{IN} = 2.75V$ to $12V$ and Adjust $I_o = 10mA$ to $1.0A$

Fixed $V_{IN} = 4.75V$ to $12V$ and Fixed $I_o = 10mA$ to $1.0A$

(For Fixed 5.0V Output Version, $V_{IN} = 7.5V$ to $12V$)

Parameter	Symbol	Test Conditions			Test Limits			Units	
		$V_{IN} - V_{OUT}$	I_o	$T_J^{(4)}$	Min	Typ	Max		
Output Voltage ⁽¹⁾	V_o	5V	10mA	25	0.99 V _o	V_o	1.01 V _o	V	
Fixed Voltage				Over Temp.	0.98 V _o		1.02 V _o		
Reference Voltage ⁽¹⁾	V_{REF}	5V	10mA	25	1.238	1.250	1.262		
Adj Voltage				Over Temp.	1.225		1.275		
Line Regulation ⁽¹⁾ ($V_{in} - V_{out} = 3V$)	$REG_{(LINE)}$		10mA	25			0.015	0.2	
				Over Temp.			0.035		
Load Regulation ⁽¹⁾ ($V_{in} - V_{out} = 3V$)	$REG_{(LOAD)}$			25			0.05	0.3	
				Over Temp.			0.2		0.4
Dropout Voltage $\Delta V_{REF} = 1\%$	V_D			25			1	V	
				Over Temp.			1.1		1.3
Current Limit ($V_{in} - V_{out} = 5V$)	I_{cL}				1.0		1.1	A	
Quiescent Current Fixed Model	I_Q	5V					12	14	mA
Temperature Coefficient	T_c						0.005		%/°C
Adjust Pin Current	I_{ADJ}			25			55	120	μA
Adjust Pin Current Change				ΔI_{ADJ}					
Temperature Stability	T_s	5V	500mA	Over Temp.			0.5		%
Minimum Load Current Adjust Model	I_o	5V					5	10	mA
RMS Output Noise ⁽²⁾	V_N			25			0.003		%V _o
Ripple Rejection Ratio ⁽³⁾	R_A	5V	1.0A	Over Temp.	60		72		dB

(1)Low duty cycle pulse testing with Kelvin connections required.

(2)Bandwidth of 10Hz to 10KHz.

(3)120Hz input ripple (C_{ADJ} for ADJ)=25 μF .

(4)Over Temp.-over specified operating junction temperature range.

1 Amp Low Dropout Positive Voltage Regulator

Typical Application Circuit

FIXED VOLTAGE REGULATOR (1)(2)

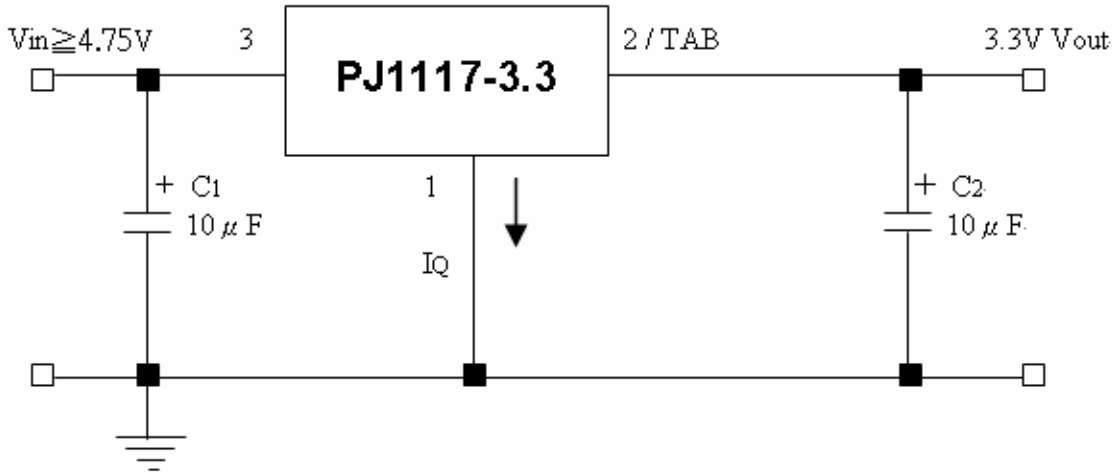

(1) C1 NEEDED IF DEVICE IS FAR FROM FILTER CAPACITORS

ADJUSTABLE VOLTAGE REGULATOR (1)(2)

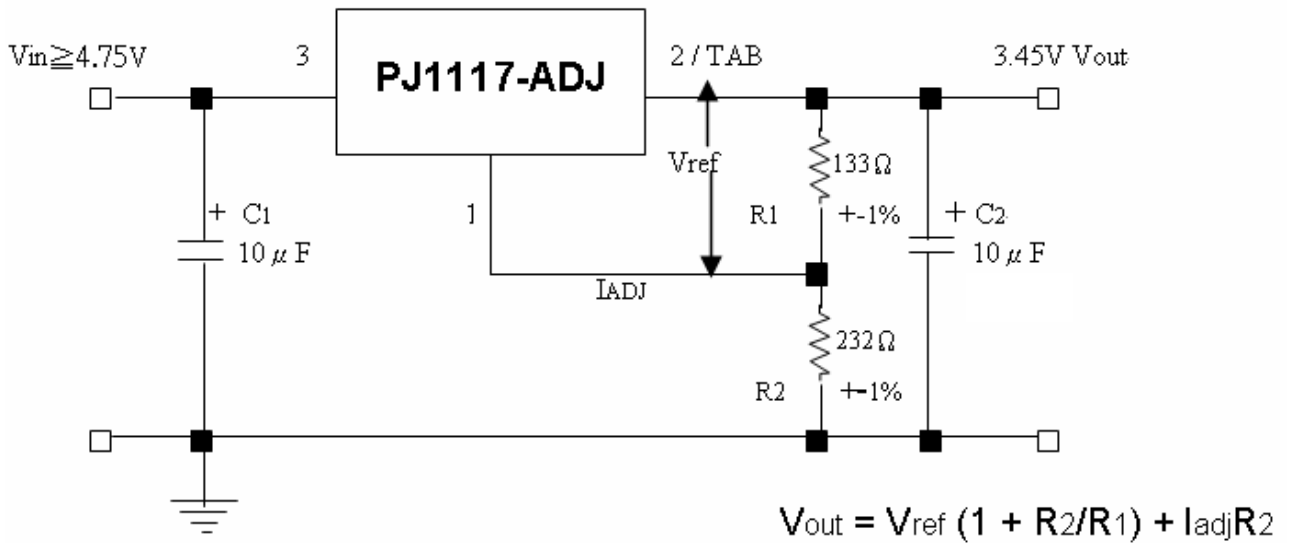

(1) C1 NEEDED IF DEVICE IS FAR FROM FILTER CAPACITORS
 (2) C2 REQUIRED FOR STABILITY

1 Amp Low Dropout Positive Voltage Regulator

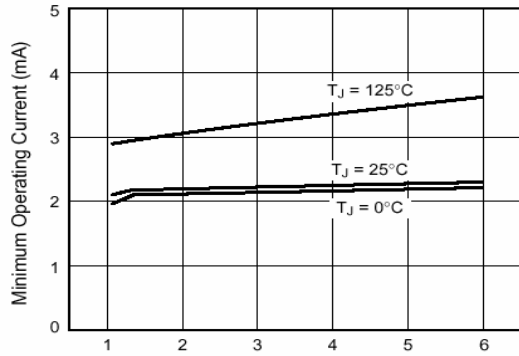

Fig. 1 – Minimum Load Current (Adjustable Version)

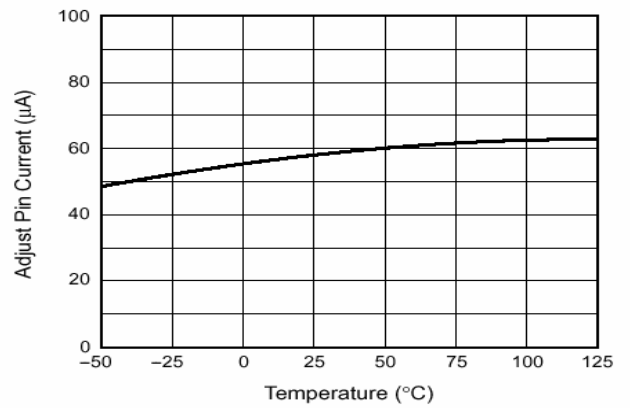

Fig. 2 – Adjust Pin Current

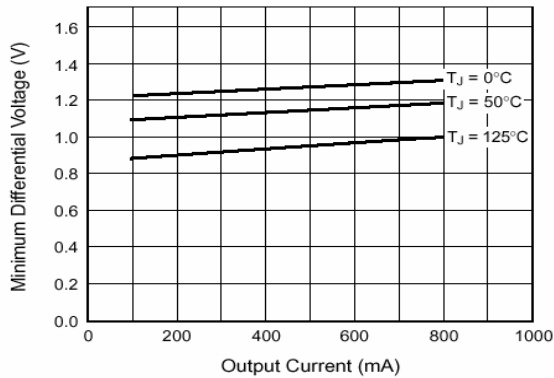

Fig. 3 – Dropout Voltage

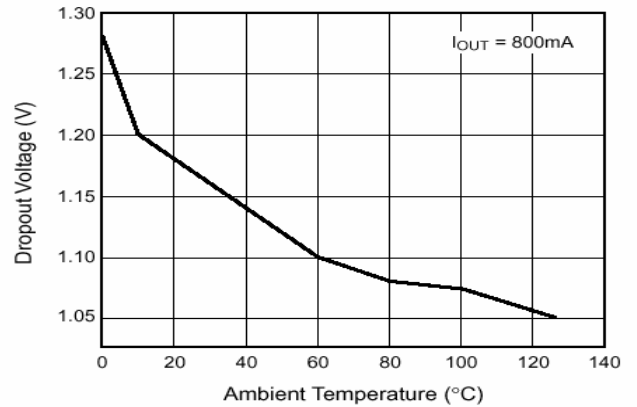

Fig. 4 – Dropout Voltage v.s. Temperature

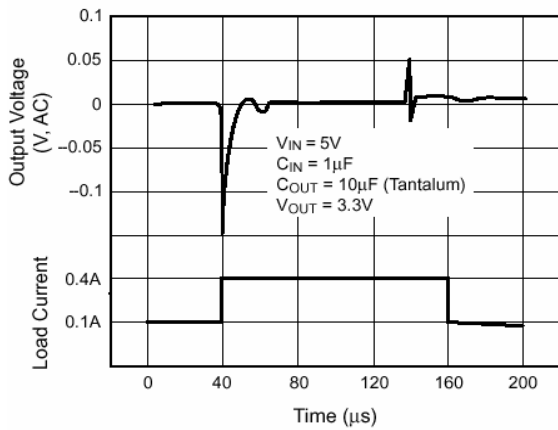

Fig. 5 – Load Transient Response

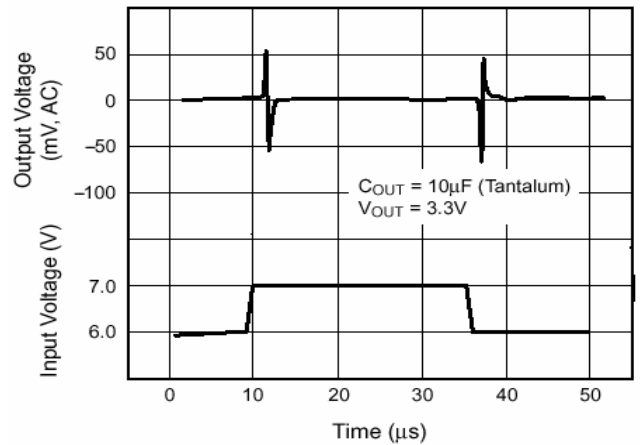

Fig. 6 – Line Transient Response

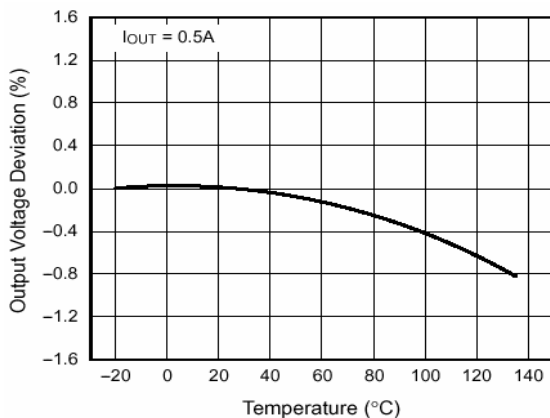

Fig. 7 – Temperature Stability

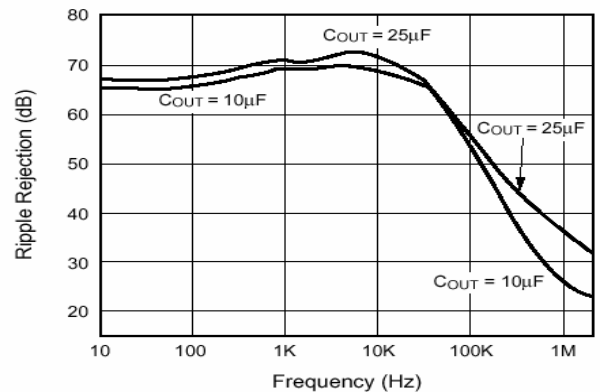
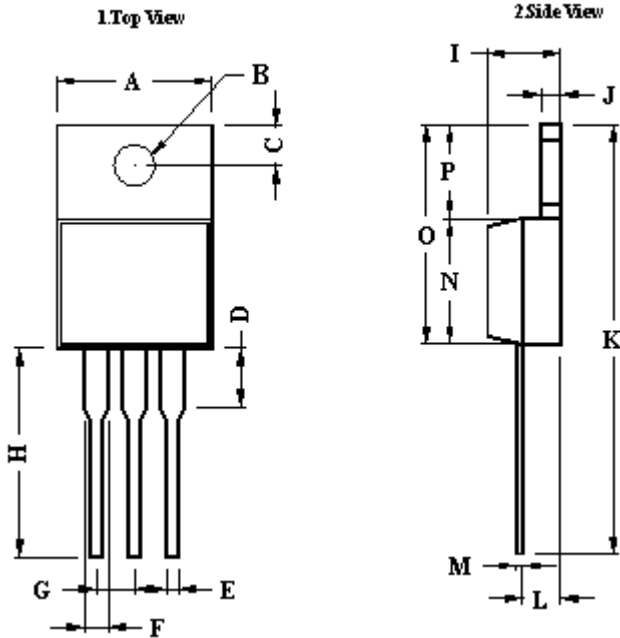

Fig. 8 – Ripple Rejection (with $C_{adj} 25\mu\text{F}$)

1 Amp Low Dropout Positive Voltage Regulator

TO-220 Mechanical drawing

TO-220 Unit:mm



TO-220 DIMENSION				
DIM	MILLIMETERS		INCHES	
	MIN	MAX	MIN	MAX
A	10.00	10.50	0.394	0.413
B	3.24	4.44	0.128	0.175
C	2.44	2.94	0.096	0.116
D	3.565	4.315	0.140	0.170
E	0.68	0.92	0.027	0.036
F	1.115	1.485	0.044	0.058
G	2.345	2.715	0.092	0.107
H	13.49	14.31	0.531	0.563
I	4.475	5.225	0.176	0.206
J	1.15	1.39	0.045	0.055
K	27.78	29.62	1.094	1.166
L	2.175	2.925	0.086	0.115
M	0.297	0.477	0.012	0.019
N	8.28	8.80	0.326	0.346
O	14.29	15.31	0.563	0.603
P	6.01	6.51	0.237	0.256

TO-263 Mechanical drawing

TO-263 Unit:mm

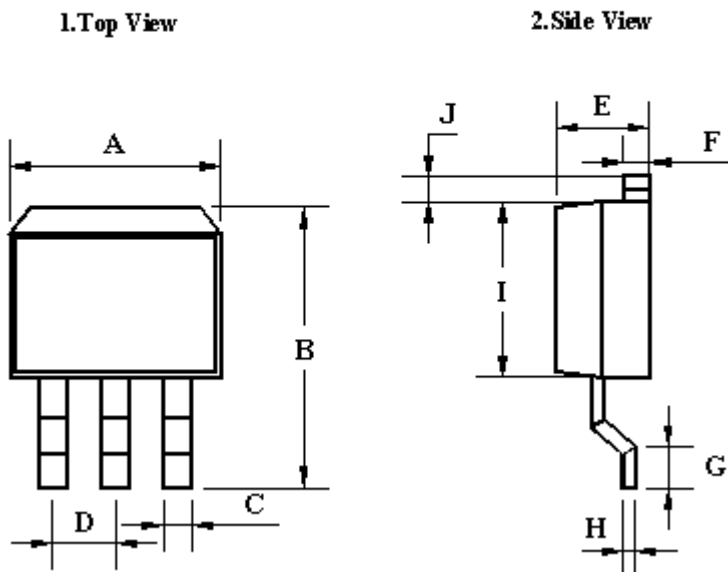

TO-263 DIMENSION				
DIM	MILLIMETERS		INCHES	
	MIN	MAX	MIN	MAX
A	10.00	10.50	0.394	0.413
B	14.60	15.87	0.575	0.625
C	0.68	0.92	0.027	0.036
D	2.42	2.66	0.095	0.105
E	4.31	4.83	0.170	0.190
F	1.14	1.40	0.045	0.055
G	2.28	2.79	0.090	0.110
H	0.45	0.73	0.018	0.029
I	8.28	8.80	0.326	0.346
J	1.14	1.4	0.045	0.055

1 Amp Low Dropout Positive Voltage Regulator

TO-252 Mechanical drawing

TO-252 Unit:mm

1.Top View

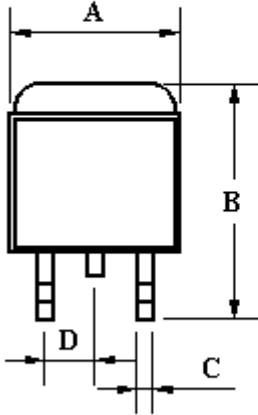

2.Side View

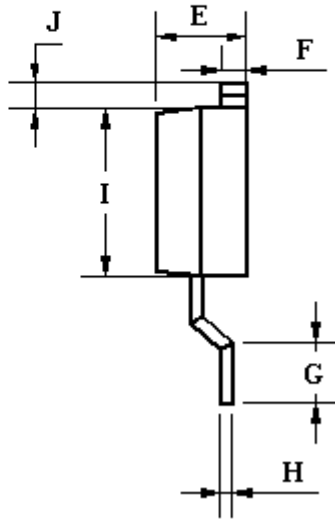

TO-252 DIMENSION				
DIM	MILLIMETERS		INCHES	
	MIN	MAX	MIN	MAX
A	6.57	6.84	0.259	0.269
B	9.25	10.40	0.364	0.409
C	0.62	0.76	0.024	0.030
D	2.56	2.67	0.101	0.105
E	2.30	2.39	0.090	0.094
F	0.49	0.57	0.019	0.022
G	1.46	1.58	0.057	0.062
H	0.52	0.57	0.020	0.022
I	5.34	5.55	0.210	0.219
J	1.46	1.64	0.057	0.065

SOT-223 Mechanical drawing

SOT-223 Unit:mm

1.Top View

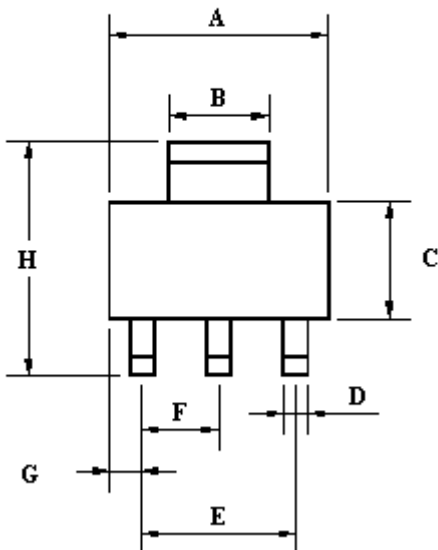

2.Side View

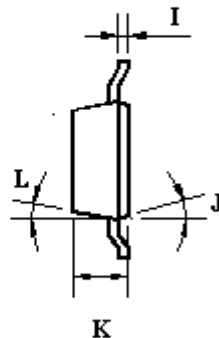

SOT-223 DIMENSION				
DIM	MILLIMETERS		INCHES	
	MIN	MAX	MIN	MAX
A	6.30	6.80	0.248	0.268
B	2.9	3.1	0.114	0.122
C	3.3	3.7	0.130	0.146
D	0.63	0.83	0.025	0.033
E	4.60	4.60	0.181	0.181
F	2.30	2.30	0.091	0.091
G	0.835	1.035	0.033	0.041
H	6.7	7.3	0.264	0.287
I	0.255	0.355	0.010	0.014
J	16°	16°	16°	16°
K	1.55	1.80	0.061	0.070
L	10°	10°	10°	10°