

## LOW PROFILE 120V AC POWER LINE SURGE SUPPRESSOR

### APPLICATIONS

- ✓ Hard Wired Equipment AC Power Protection
- ✓ Load Side Distribution Systems
- ✓ Secondary Protection for Light Industrial AC Power

### IEC COMPATIBILITY (EN61000-4)

- ✓ 61000-4-5 (Surge): 1kA, 8/20 $\mu$ s - Level 4(Line-Line) & 333A Level 4 (Line-Ground)

### FEATURES

- ✓ Meets ANSI/IEEE C62.41 Requirements
- ✓ Listed to CSA, File LR65240
- ✓ Differential and Common Mode Protection
- ✓ Low Clamping Voltage
- ✓ Nanosecond Response Time
- ✓ Long Life and Maintenance Free
- ✓ Finger Safe Connectors

### MECHANICAL CHARACTERISTICS

- ✓ Plastic Package
- ✓ Weight 360 Grams (Approximate)
- ✓ Flammability Rating UL 94V-0
- ✓ Device Marking: Part Number , Logo, Voltage and Current Rating

### DESCRIPTION

The 587B Low Profile (LP) Series of 120 Volt AC Surge Suppressors is designed for use by the OEM, equipment installer and or maintenance contractor. These modules employ a three stage technology proven to be the most cost effective and reliable method in protecting sensitive electronic equipment from over voltage transients.

This series is designed to protect AC powered equipment from the 6,000 Volt peak open circuit voltage and 3,000 Amp short circuit current as defined in ANSI/IEEE C62.41, Category C1.

The 587BxxxLP Series offers a high degree of protection against 120 VAC line noise. It is ideal for protecting 400 Volt components because the solid state TVS technology assures that the line-to-neutral voltage will not exceed 400 Volts. While the modules are designed for transient voltage protection, the advanced circuitry will also attenuate the amplitude and slow the rate of rise of high frequency noise. The 587BxxxLP Series includes common mode and differential mode protection, which are effective in reducing interference from line to equipment and are effective in reducing equipment generated noise to meet FCC, VDE and CSA interference requirements

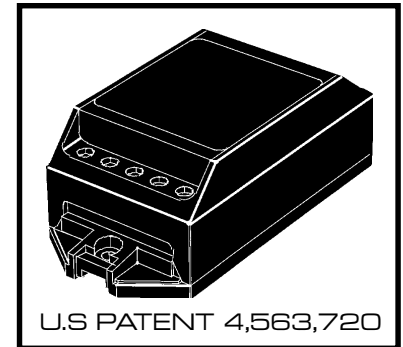

**FIGURE 1**  
**TRANSIENT VOLTAGE THREAT**  
**CONDITION**

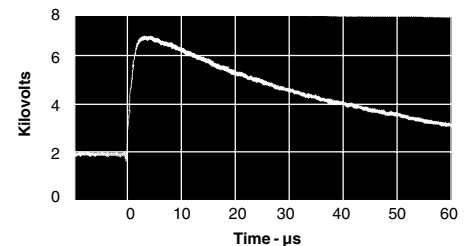

**FIGURE 2**  
**TYPICAL CLAMPING ACTION**  
**OF A 15 AMP MODULE**

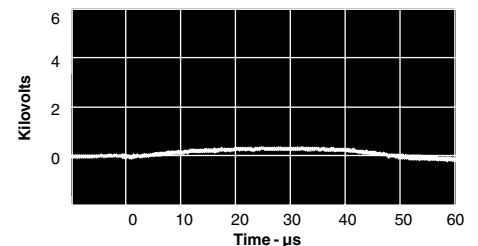

Figures 1 and 2 are photographs of digitized waveforms showing the typical clamping action of a 15 ampere module. A 12 Ohm resistor is used to represent a 10 Amp equipment load. The load is then subjected to the ANSI/IEEE C62.41 Category C1 test conditions (6,000V/3,000A). These photographs contrast the effect on equipment with and without the protector.

# 587B051LP thru 587B301LP

## DEVICE CHARACTERISTICS

SPECIFICATIONS @ 25°C				
MAXIMUM RATINGS	RESPONSE TO TRANSIENT VOLTAGES			
Operating Line Voltage: 130 VAC Max Maximum Line Current: 587B051LP: 5A 587B101LP: 10A 587B151LP: 20A 587B301LP: 30A  Transient Voltage: 6000V <sub>peak</sub> Transient Current: 3000A <sub>peak</sub> Current Leakage: @ 130 VAC Line-to-Neutral: 1.0mA Neutral-to-Ground: 1.0mA Line-to-Ground: 1.0mA Storage & Operating Temperature: -40°C to 85°C (Measured at center of mounting surface)	CLAMPING		TEST CONDITION	
	PROTECTION MODE	MAXIMUM CLAMPING VOLTAGE	OPEN CIRCUIT VOLTAGE @ 1.2/50 μs	SHORT CIRCUIT CURRENT @ 8/20 μs
	DIFFERENTIAL (Line-to-Neutral)	295V 330V	1000V 6000V	500A 3000A
COMMON (Neutral-to-Ground) (Line-to-Ground)	500V 500V	1000V 6000V	500A 3000A	

### ARRESTER DEFINITIONS

**Clamping Voltage:** The clamping voltage of an arrester is the voltage that appears across its terminals during conduction of a transient current.

**Standard Wave Form:** The waveform of a surge current or voltage is designated by a combination of two numbers. The first number is for the time of the wave front expressed in microseconds from zero to the peak of the wave. The second number is for the time of the wavetail also expressed in microseconds from zero to the instant that the wavetail reaches one half of the crest or peak value. Example, 8/20 μs waveform.

**Transient Current:** The transient current of an arrester is the peak surge current which flows through the arrester when voltage clamping occurs.

### OPERATION

For maximum effectiveness, the protector should be installed directly after the AC line on/off switch and fuse. This will protect the electronics from the AC line switch arcing and the severe transients caused by a fuse clearing.

Some heat is produced when operating at full current load, and heat sinking may be required to maintain case temperature below 85°C. The case temperature is measured at the center of the mounting surface. The unit should not be mounted to a low combusting temperature material such as wood.

High energy transients will cause a large circulating current in the AC input line (2,500A is possible). To prevent electromagnetic coupling, the AC line on the input side of the protector must be dressed away from other wiring, magnetic shielding may be required. In addition, the electrical service must be connected to a low impedance earth ground.

# 587B051LP thru 587B301LP

## PACKAGE OUTLINE & DIMENSIONS

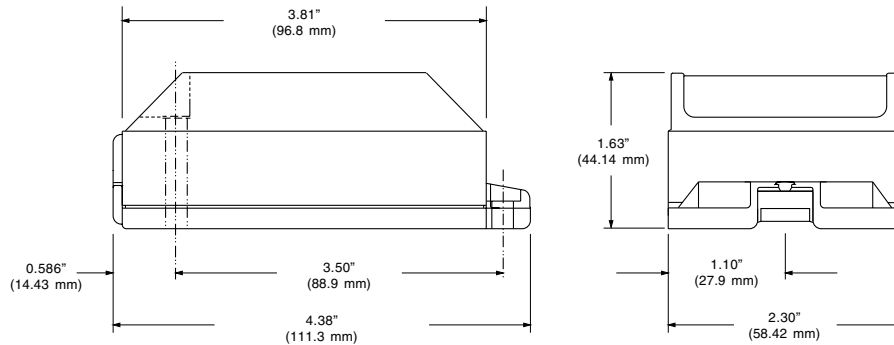

**Note:** Connector accepts 10-24 gauge wire.

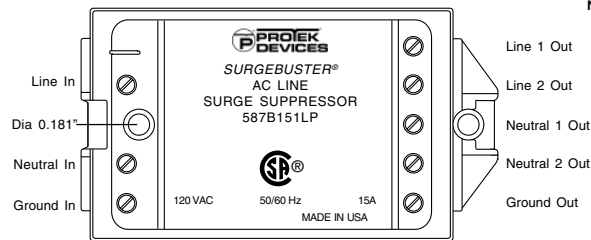

ProTek Devices  
2929 South Fair Lane, Tempe, AZ 85282  
Tel: 602-431-8101 Fax: 602-431-2288  
E-Mail: [sales@protekdevices.com](mailto:sales@protekdevices.com)  
Web Site: [www.protekdevices.com](http://www.protekdevices.com)

**COPYRIGHT © ProTek Devices 2003**

SPECIFICATIONS: ProTek reserves the right to change the electrical and/or mechanical characteristics described herein without notice (except JEDEC).

DESIGN CHANGES: ProTek reserves the right to discontinue product lines without notice, and that the final judgement concerning selection and specifications is the buyer's and that in furnishing engineering and technical assistance, ProTek assumes no responsibility with respect to the selection or specifications of such products.