

## ULTRA LOW CAPACITANCE TVS ARRAY

### APPLICATIONS

- ✓ Low Voltage Wireless Equipment
- ✓ Sensor & Control Circuits
- ✓ Ethernet - 10/100 Base T
- ✓ FireWire

### IEC COMPATIBILITY (EN61000-4)

- ✓ 61000-4-2 (ESD): Air - 15kV, Contact - 8kV
- ✓ 61000-4-4 (EFT): 40A - 5/50ns
- ✓ 61000-4-5 (Surge): 24A, 8/20 $\mu$ s - Level 2(Line-Ground) & Level 3(Line-Line)

### FEATURES

- ✓ 250 Watts Peak Pulse Power per Line ( $t_p = 8/20\mu$ s)
- ✓ Unidirectional Configuration
- ✓ ESD Protection > 25 kilovolts
- ✓ Low Clamping Voltage < 5 Volts
- ✓ **ULTRA LOW CAPACITANCE: 2.5pF**

### MECHANICAL CHARACTERISTICS

- ✓ Molded JEDEC SOT-23
- ✓ Weight 14 milligrams (Approximate)
- ✓ Flammability rating UL 94V-0
- ✓ 8mm Tape and Reel Per EIA Standard 481
- ✓ Device Marking: Marking Code

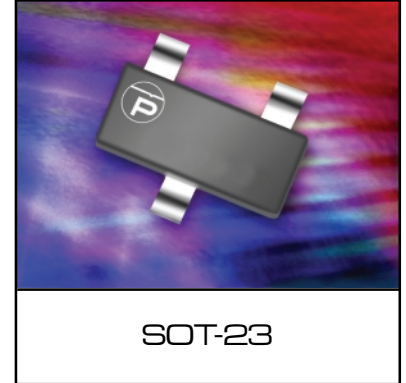

### PIN CONFIGURATION

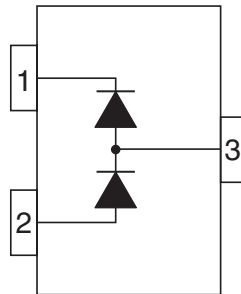

DEVICE CHARACTERISTICS

MAXIMUM RATINGS @ 25°C Unless Otherwise Specified			
PARAMETER	SYMBOL	VALUE	UNITS
Peak Pulse Power - $t_p = 8/20\mu s$ (See Figure 1)	$P_{PP}$	250	W
Operating Temperature	$T_J$	-55°C to 150°C	°C
Storage Temperature	$T_{STG}$	-55°C to 150°C	°C

ELECTRICAL CHARACTERISTICS PER LINE @ 25°C Unless Otherwise Specified								
PART NUMBER	DEVICE MARKING CODE	RATED STAND-OFF VOLTAGE	MINIMUM BREAKDOWN VOLTAGE (See Note 1)	MAXIMUM REVERSE LEAKAGE CURRENT (See Note 1)	MAXIMUM CLAMPING VOLTAGE (See Note 1) (See Fig. 2)	MAXIMUM WORKING INVERSE BLOCKING VOLTAGE (See Note 2)	INVERSE BLOCKING LEAKAGE CURRENT (See Note 2)	MAXIMUM CAPACITANCE (See Note 3)
		$V_{WM}$ VOLTS	@1mA $V_{(BR)}$ VOLTS	@ $V_{WM}$ $I_D$ $\mu A$	@8/20 $\mu s$ $V_C$ @ $I_{PP}$	$V_{WB}$ VOLTS	@ $V_{WB}$ $I_R$ $\mu A$	@0V, 1MHz C pF
PLC497	LC	1.0	1.3	20	5.0V @ 50A	75	1.0	2.5

- Note 1:** Apply positive voltage from pin2 to 1.
- Note 2:** Apply positive voltage from pin 1 to 2.
- Note 3:** Capacitance from pin 1 to 2 < 2.5pF.

**FIGURE 1**  
PEAK PULSE POWER VS PULSE TIME

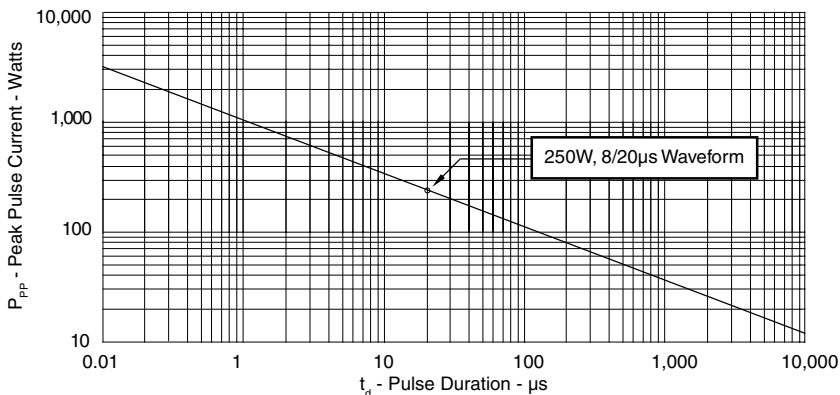

**FIGURE 2**  
PULSE WAVE FORM

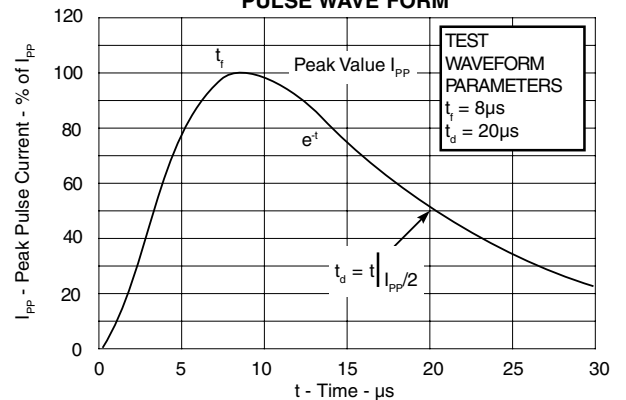

GRAPHS

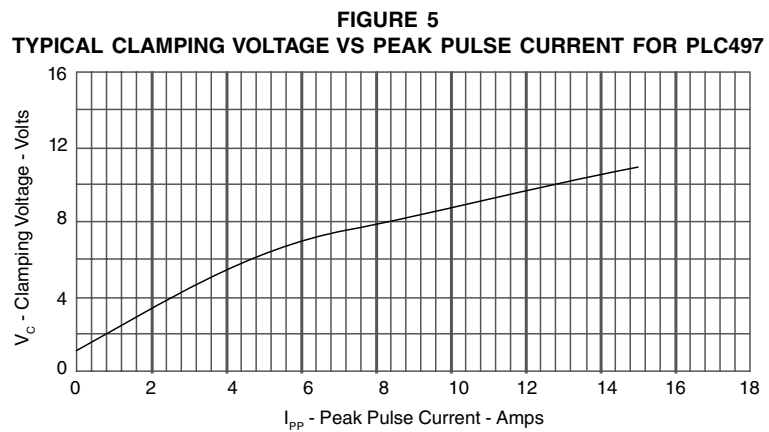
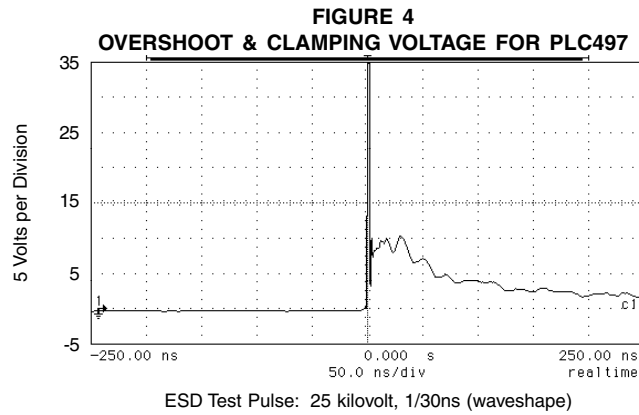
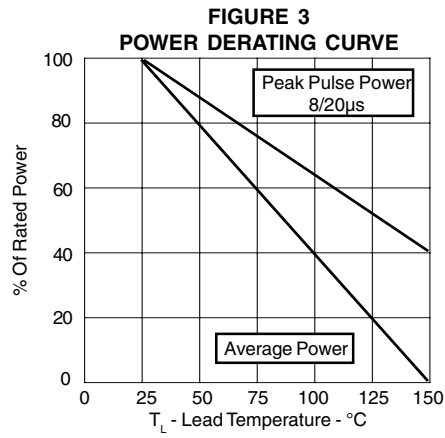

## APPLICATION NOTE

The PLC497 is an ultra low capacitance, bidirectional array that is designed to protect I/O or high speed data lines from the damaging effects of ESD or EFT. This product has a surge capability of 250 Watts  $P_{PP}$  per line for an 8/20 $\mu$ s wave form and offers ESD protection > 40kV.

### DIFFERENTIAL-MODE CONFIGURATION (Figure 1)

The PLC497 is designed to protect one unidirectional line. Figure 1 shows a typical differential-mode (line to line) I/O port protection circuit application. To achieve bidirectional protection, two PLC497 units are placed in parallel with opposing polarities within the circuit layout.

Circuit connectivity is as follows:

- ✓ Pins 1 and 2 of each device connected to datalines
- ✓ Pin 3 is not connected

### COMMON-MODE CONFIGURATION (Figure 2)

The PLC497 can provide protection for sensor circuit applications. Figure 2 is a typical common-mode (line to ground) sensor circuit application. To achieve bidirectional protection in this application, a second pair of TVS devices is added in parallel with opposing polarities where pins 2 are connected to the line, pins 1 connected to ground and pins 3 unconnected.

Circuit connectivity is as follows:

- ✓ Pins 1 each device connected to datalines
- ✓ Pins 2 each device connected to ground
- ✓ Pin 3 is not connected

### CIRCUIT BOARD LAYOUT RECOMMENDATIONS

Circuit board layout is critical for Electromagnetic Compatibility (EMC) protection. The following guidelines are recommended:

- ✓ The protection device should be placed near the input terminals or connectors, the device will divert the transient current immediately before it can be coupled into the nearby traces.
- ✓ The path length between the TVS device and the protected line should be minimized.
- ✓ All conductive loops including power and ground loops should be minimized.
- ✓ The transient current return path to ground should be kept as short as possible to reduce parasitic inductance.
- ✓ Ground planes should be used whenever possible. For multilayer PCBs, use ground vias.

Figure 1. Typical Differential-Mode i/o Port Protection Circuit

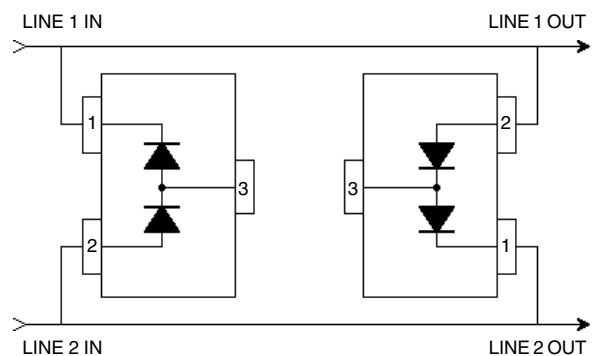
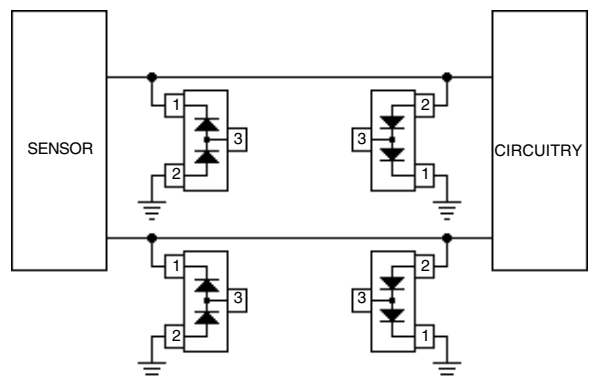
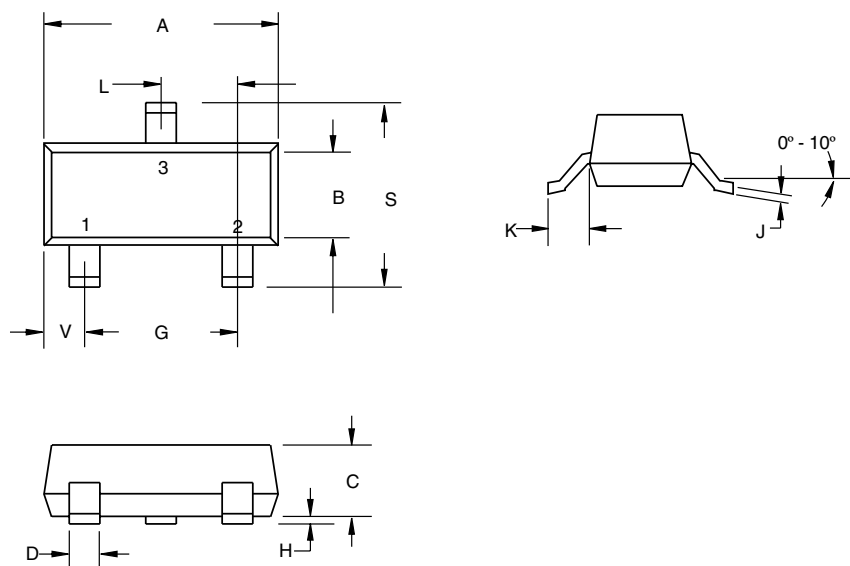

Figure 2. Typical Common-Mode Sensor Protection Circuit



## PACKAGE OUTLINE & DIMENSIONS

### PACKAGE OUTLINE



### SOT-23



### PACKAGE DIMENSIONS

DIM	MILLIMETERS		INCHES	
	MIN	MAX	MIN	MAX
A	2.80	3.04	0.1102	0.1197
B	1.20	1.40	0.0472	0.0551
C	0.89	1.11	0.0350	0.0440
D	0.37	0.50	0.0150	0.0200
G	1.78	2.04	0.0701	0.0807
H	0.013	0.100	0.0005	0.0040
J	0.085	0.177	0.0034	0.0070
K	0.45	0.60	0.0180	0.0236
L	0.89	1.02	0.0350	0.0401
S	2.10	2.50	0.0830	0.0984
V	0.45	0.60	0.0177	0.0236

### MOUNTING PAD

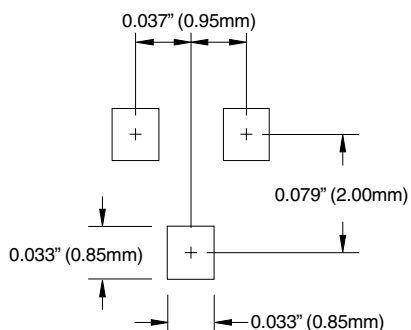

### NOTES

1. Dimensioning and tolerances per ANSI Y14.5M, 1985.
2. Controlling Dimension: Inches
3. Pin 3 is the cathode (Unidirectional Only).
4. Dimensions are exclusive of mold flash and metal burrs.

### TAPE & REEL ORDERING NOMENCLATURE

1. Surface mount product is taped and reeled in accordance with EIA-481.
2. Suffix -T7 = 7 Inch Reel - 3,000 pieces per 8mm tape, i.e., PLC497-T7.
3. Suffix -T13 = 13 Inch Reel - 10,000 pieces per 8mm tape, i.e., PLC497-T13.

Outline & Dimensions: Rev 1 - 11/01, 06012

**COPYRIGHT © ProTek Devices 2003**

SPECIFICATIONS: ProTek reserves the right to change the electrical and or mechanical characteristics described herein without notice (except JEDEC).

DESIGN CHANGES: ProTek reserves the right to discontinue product lines without notice, and that the final judgement concerning selection and specifications is the buyer's and that in furnishing engineering and technical assistance, ProTek assumes no responsibility with respect to the selection or specifications of such products.

### ProTek Devices

2929 South Fair Lane, Tempe, AZ 85282

Tel: 602-431-8101 Fax: 602-431-2288

E-Mail: [sales@protekdevices.com](mailto:sales@protekdevices.com)

Web Site: [www.protekdevices.com](http://www.protekdevices.com)