

LOW CAPACITANCE TVS ARRAY

APPLICATIONS

- ✓ SCSI & IDE Interfaces
- ✓ Parallel & Serial Port Protection (RS-232)
- ✓ Ethernet - 10/100 Base T
- ✓ Test & Measurement Equipment
- ✓ Industrial Control: Low Voltage Sensors

IEC COMPATIBILITY (EN61000-4)

- ✓ 61000-4-2 (ESD): Air - 15kV, Contact - 8kV
- ✓ 61000-4-4 (EFT): 40A - 5/50ns
- ✓ 61000-4-5 (Surge): 12A, 8/20 μ s - Level 1(Line-Gnd) & Level 2(Line-Line)

FEATURES

- ✓ 500 Watts Peak Pulse Power per Line ($t_p=8/20\mu$ s)
- ✓ Unidirectional & Bidirectional Configurations
- ✓ Available in Multiple Voltage Types Ranging From 3V to 24V
- ✓ Protects Up to Four (4) Lines
- ✓ ESD Protection > 40 kilovolts
- ✓ **LOW CAPACITANCE: 15pF**

MECHANICAL CHARACTERISTICS

- ✓ Molded JEDEC SO-8 Package
- ✓ Weight 15 milligrams (Approximate)
- ✓ Flammability rating UL 94V-0
- ✓ 12mm Tape and Reel Per EIA Standard 481
- ✓ Marking: Logo, Marking Code, Date Code & Pin One Defined By Dot on Top of Package



PIN CONFIGURATIONS

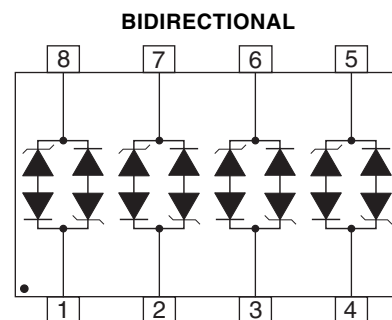
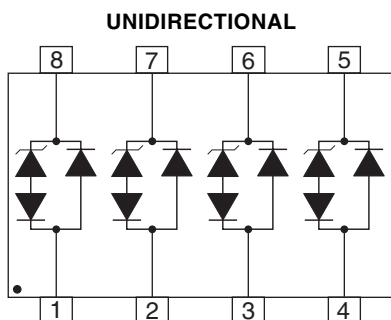

DEVICE CHARACTERISTICS

MAXIMUM RATINGS @ 25°C Unless Otherwise Specified			
PARAMETER	SYMBOL	VALUE	UNITS
Peak Pulse Power ($t_p = 8/20\mu s$) - See Figure 1	P_{PP}	500	Watts
Operating Temperature	T_J	-55°C to 150°C	°C
Storage Temperature	T_{STG}	-55°C to 150°C	°C
Forward Voltage @ 50mA, 300μs - Square Wave (Note 1)	V_F	1.5	Volts

Note 1: Only applies to unidirectional devices.

ELECTRICAL CHARACTERISTICS PER LINE @ 25°C Unless Otherwise Specified							
PART NUMBER (See Note 1)	DEVICE MARKING	RATED STAND-OFF VOLTAGE	MINIMUM BREAKDOWN VOLTAGE	MAXIMUM CLAMPING VOLTAGE (See Fig. 2)	MAXIMUM CLAMPING VOLTAGE (See Fig. 2)	MAXIMUM LEAKAGE CURRENT	MAXIMUM CAPACITANCE
		V_{WM} VOLTS	@ 1mA $V_{(BR)}$ VOLTS	@ $I_p = 1A$ V_C VOLTS	@ 8/20μs $V_C @ I_{PP}$	@ V_{WM} I_D μA	0V @ 1 MHz C pF
SMDA03LC	SLA	3.3	4.5	7.0	10.9V @ 43.0A	125	15
SMDA03LCC	SLB	3.3	4.5	7.0	10.9V @ 43.0A	125	15
SMDA05LC	SLC	5.0	6.0	9.8	13.5V @ 42.0A	20	15
SMDA05LCC	SLD	5.0	6.0	9.8	13.5V @ 42.0A	20	15
SMDA08LC	SLE	8.0	8.5	13.4	16.9V @ 34.0A	10	15
SMDA08LCC	SLF	8.0	8.5	13.4	16.9V @ 34.0A	10	15
SMDA12LC	SLG	12.0	13.3	19.0	25.9V @ 27.0A	1	15
SMDA12LCC	SLH	12.0	13.3	19.0	25.9V @ 27.0A	1	15
SMDA15LC	SLJ	15.0	16.7	24.0	30.0V @ 17.0A	1	15
SMDA15LCC	SLK	15.0	16.7	24.0	30.0V @ 17.0A	1	15
SMDA24LC	SLL	24.0	26.7	43.0	49.0V @ 12.0A	1	15
SMDA24LCC	SLM	24.0	26.7	43.0	49.0V @ 12.0A	1	15

Note 1: Part numbers with a "C" suffix are bidirectional devices, i.e., SMDA03LCC.

GRAPHS

**FIGURE 1
 PEAK PULSE POWER VS PULSE TIME**

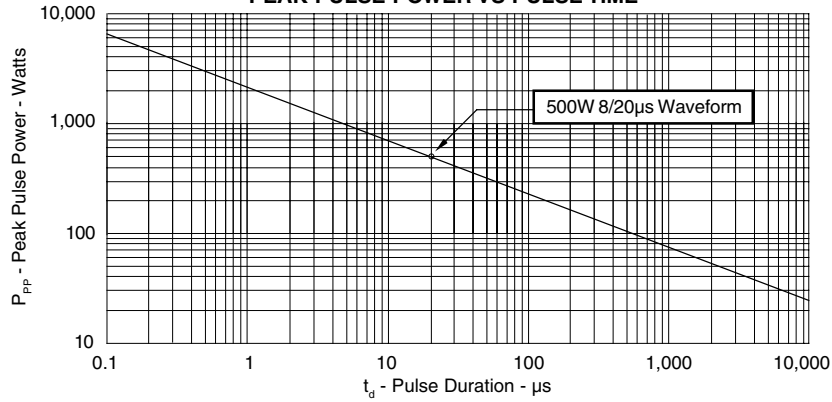

**FIGURE 2
 PULSE WAVE FORM**

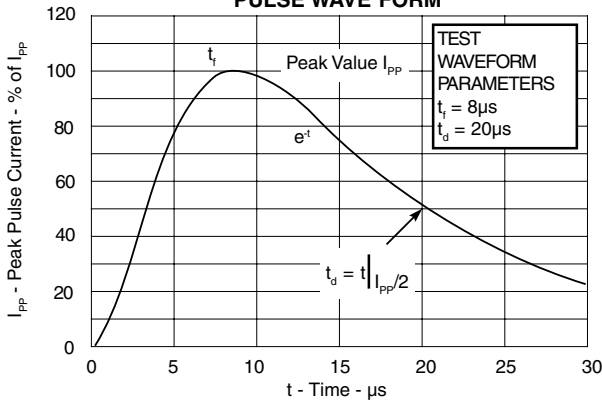

**FIGURE 3
 POWER DERATING CURVE**

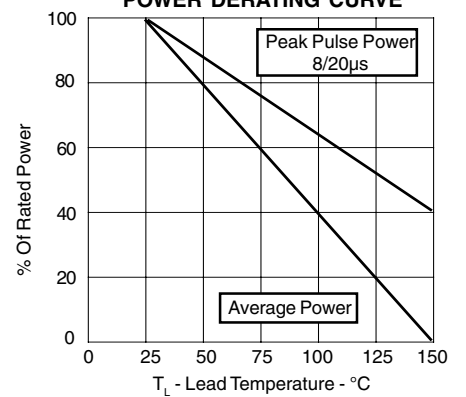

**FIGURE 4
 OVERSHOOT & CLAMPING VOLTAGE FOR SMDA05LC**

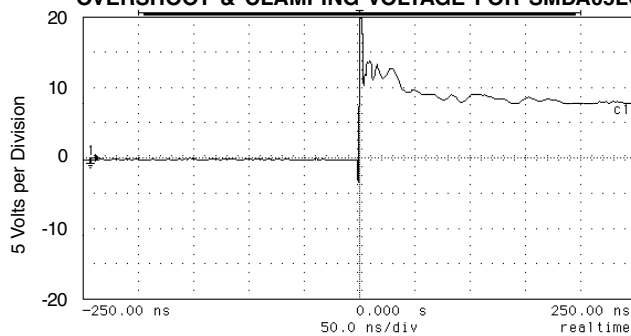

ESD Test Pulse: 5 kilovolt, 1/30ns (waveform)

APPLICATION NOTE

The SMDAxxLC & SMDAxxLCC Series are TVS arrays designed to protect I/O or data lines from the damaging effects of ESD, EFT and other types of surges. This product series provides both unidirectional and bidirectional protection, with a surge capability of 500 Watts P_{PP} per line for an 8/20µs waveform and ESD protection > 40kV.

UNIDIRECTIONAL COMMON-MODE CONFIGURATION(Figure 1)

The SMDAxxLC Series provides up to four (4) lines of protection in a common-mode configuration as depicted in Figure 1. Circuit connectivity is as follows:

- ✓ Line 1 is connected to Pin 5.
- ✓ Line 2 is connected to Pin 6.
- ✓ Line 3 is connected to Pin 7.
- ✓ Line 4 is connected to Pin 8.
- ✓ Pins 1-4 are connected to ground.

BIDIRECTIONAL COMMON-MODE CONFIGURATION (Figure 2)

Ideal for Ethernet applications, SMDAxxLCC Series provides up to four (4) lines of protection in a common-mode configuration as depicted in Figure 2.

Circuit connectivity is as follows:

- ✓ TPIN is connected to Pin 5.
- ✓ TPIP is connected to Pin 6.
- ✓ TPON is connected to Pin 1.
- ✓ TPOP is connected to Pin 2.
- ✓ Pins 3, 4, 7 & 8 are connected to ground.

CIRCUIT BOARD LAYOUT RECOMMENDATIONS

Circuit board layout is critical for Electromagnetic Compatibility (EMC) protection. The following guidelines are recommended:

- ✓ The protection device should be placed near the input terminals or connectors, the device will divert the transient current immediately before it can be coupled into the nearby traces.
- ✓ The path length between the TVS device and the protected line should be minimized.
- ✓ All conductive loops including power and ground loops should be minimized.
- ✓ The transient current return path to ground should be kept as short as possible to reduce parasitic inductance.
- ✓ Ground planes should be used whenever possible. For multilayer PCBs, use ground vias.

Figure 1. Unidirectional Common-Mode Protection

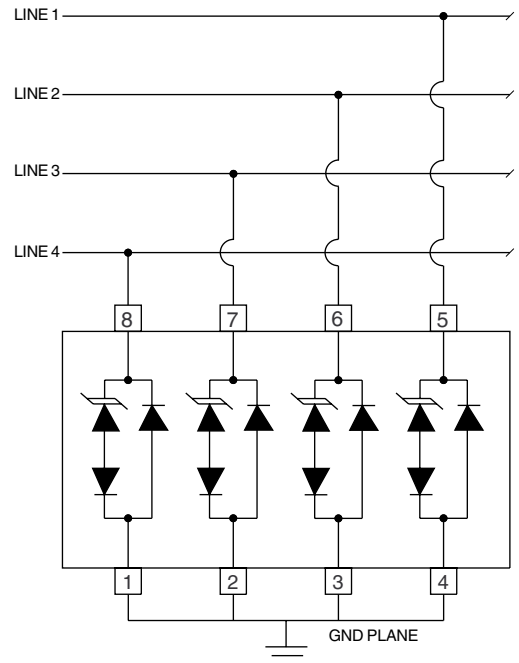
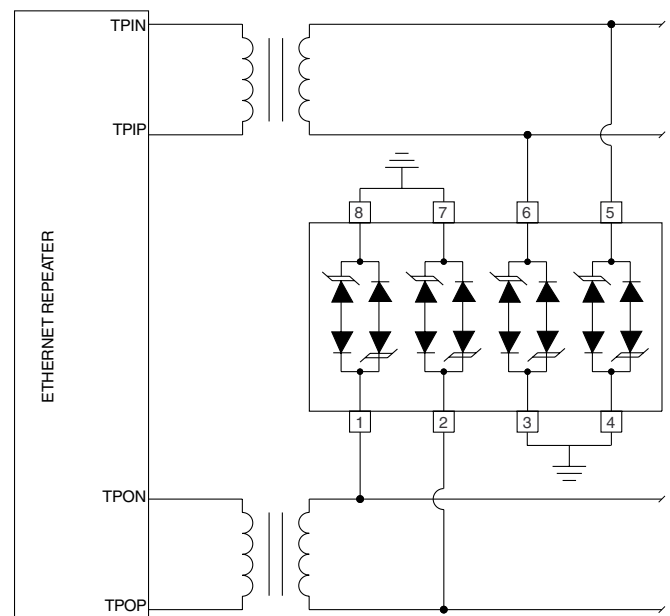
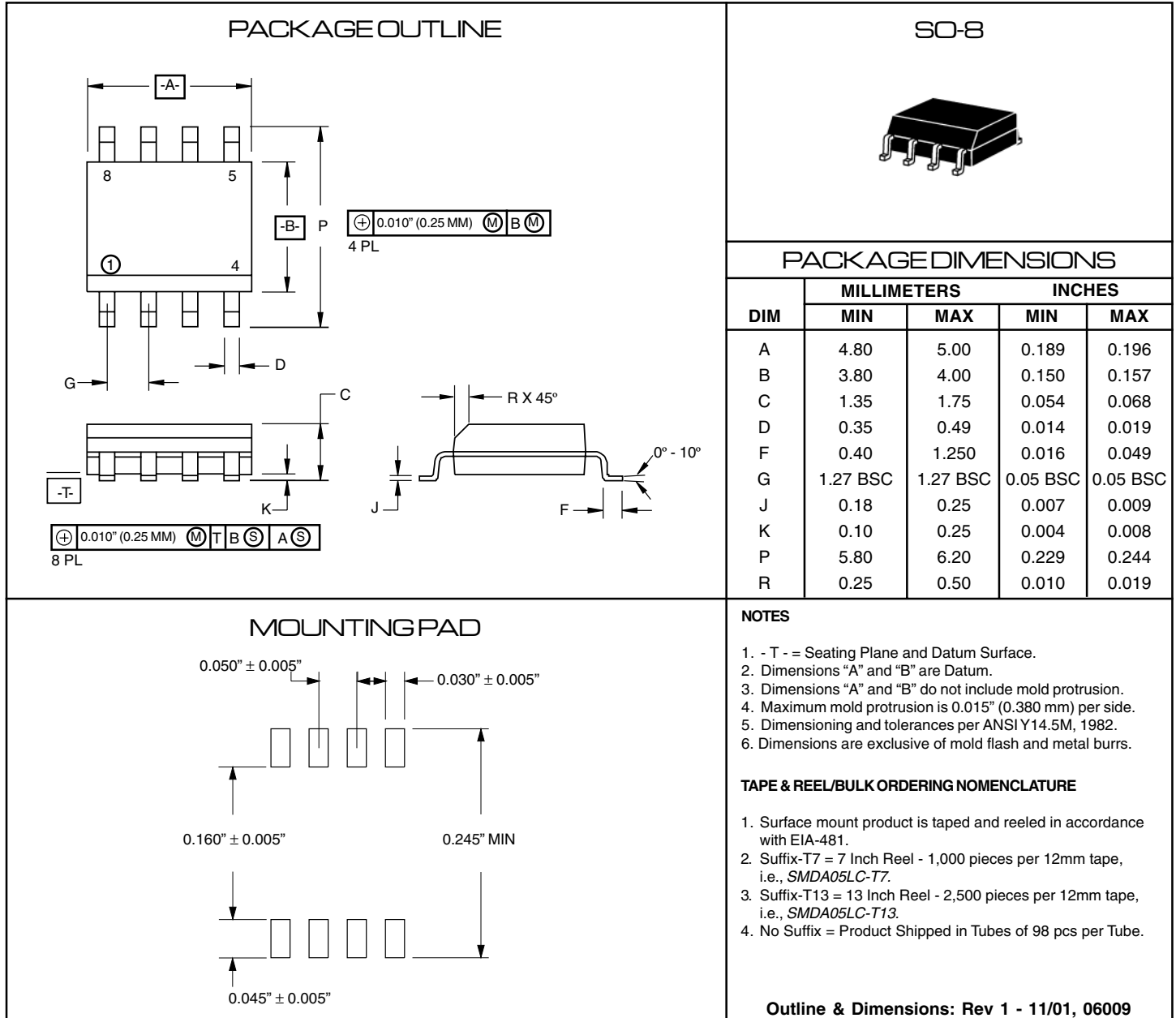

Figure 2. Bidirectional Common-Mode Protection



PACKAGE OUTLINE & DIMENSIONS



COPYRIGHT © ProTek Devices 2003

SPECIFICATIONS: ProTek reserves the right to change the electrical and or mechanical characteristics described herein without notice (except JEDEC).

DESIGN CHANGES: ProTek reserves the right to discontinue product lines without notice, and that the final judgement concerning selection and specifications is the buyer's and that in furnishing engineering and technical assistance, ProTek assumes no responsibility with respect to the selection or specifications of such products.

ProTek Devices
 2929 South Fair Lane, Tempe, AZ 85282
 Tel: 602-431-8101 Fax: 602-431-2288
 E-Mail: sales@protekdevices.com
 Web Site: www.protekdevices.com