

Powerex, Inc., 200 Hillis Street, Youngwood, Pennsylvania 15697-1800 (412) 925-7272
 Powerex, Europe, S.A. 428 Avenue G. Durand, BP107, 72003 Le Mans, France (43) 41.14.14

General Purpose Rectifier

2500 Amperes Average
 2200 Volts

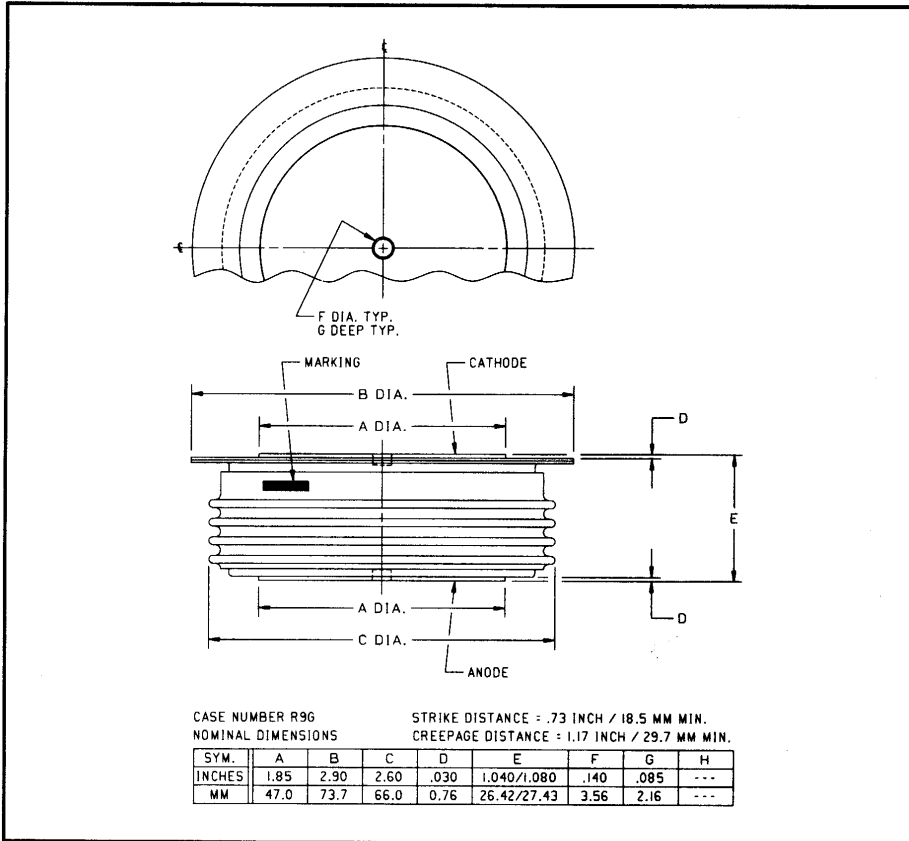

A451 (Outline Drawing)

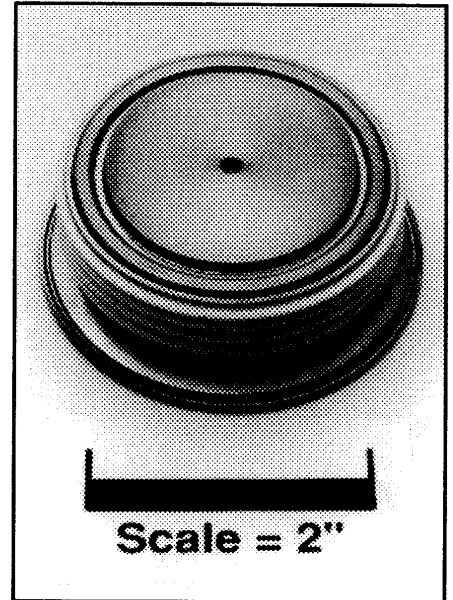

A451 General Purpose Rectifier
 2500 Amperes Average, 2200 Volts

Description:

Powerex General Purpose Rectifiers are designed for high blocking voltage capability with low forward voltage to minimize conduction losses. These hermetic Pow-R-Disc devices can be mounted using commercially available clamps and heatsinks.

Features:

- Low Forward Voltage
- Low Thermal Impedance
- Hermetic Packaging
- Excellent Surge and I^2t Ratings

Applications:

- Power Supplies
- Motor Control
- Free Wheeling Diodes
- Battery Chargers
- Resistance Welding

Ordering Information:

Select the complete five or six digit part number you desire from the table, i.e. A451LB is a 2200 Volt, 2500 Ampere General Purpose Rectifier.

Type	Voltage		Current $I_T(av)$
	V_{RRM}	Code	
A451	1400	PD	2500
	1600	PM	
	1800	PN	
	2000	L	
	2200	LB	



Powerex, Inc., 200 Hillis Street, Youngwood, Pennsylvania 15697-1800 (412) 925-7272
Powerex, Europe, S.A. 428 Avenue G. Durand, BP107, 72003 Le Mans, France (43) 41.14.14

A451
General Purpose Rectifier
2500 Amperes Average, 2200 Volts

Absolute Maximum Ratings

Characteristics	Symbol	A451	Units
Non-repetitive Transient Peak Reverse Voltage	V_{RSM}	$V_{RRM} + 100V$	Volts
RMS Forward Current, $T_C = 88^\circ C$	$I_{F(rms)}$	3925	Amperes
Average Current 180° Sine Wave, $T_C = 88^\circ C$	$I_{F(av)}$	2500	Amperes
RMS Forward Current, $T_C = 55^\circ C$	$I_{F(rms)}$	4830	Amperes
Average Current 180° Sine Wave, $T_C = 55^\circ C$	$I_{F(av)}$	3075	Amperes
Peak One Cycle Surge Forward Current (Non-repetitive) 60Hz	I_{fsm}	30000	Amperes
Peak One Cycle Surge Forward Current (Non-repetitive) 50Hz	I_{fsm}	27300	Amperes
I^2t (for Fusing) for One Cycle, 60Hz	I^2t	1,892,250	A^2sec
Operating Temperature	T_j	-40 to +175°C	°C
Storage Temperature	T_{stg}	-40 to +200°C	°C
Approximate Weight		1	lb.
		454	g
Mounting Force		5000 to 5500	lb.
		22.2 to 24.5	kN



Powerex, Inc., 200 Hillis Street, Youngwood, Pennsylvania 15697-1800 (412) 925-7272
 Powerex, Europe, S.A. 428 Avenue G. Durand, BP107, 72003 Le Mans, France (43) 41.14.14

A451
 General Purpose Rectifier
 2500 Amperes Average, 2200 Volts

Electrical Characteristics, $T_j = 25^\circ\text{C}$ Unless Otherwise Specified

Characteristics	Symbol	Test Conditions	Min.	Typ.	Max.	Units
Repetitive Reverse Leakage Current	I_{RRM}	$T_j = 175^\circ\text{C}, V_R = V_{RRM}$			50	mA
Forward Voltage Drop	V_{FM}	$T_j = 25^\circ, I_{FM} = 5000\text{A Peak}$ Duty Cycle < 0.1%			1.4	Volts
Threshold Voltage, Low-level	$V_{(TO)1}$	$T_j = 175^\circ\text{C}, I = 15\%, I_{T(av)}$ to $\pi I_{T(av)}$			0.66127	Volts
Slope Resistance, Low-level	r_{T1}				0.1281	m Ω
Threshold Voltage, High-level	$V_{(TO)2}$	$T_j = 175^\circ\text{C}, I = \pi I_{T(av)}$ to I_{TSM}			0.90714	Volts
Slope Resistance, High-level	r_{T2}				0.08478	m Ω
V_{TM} Coefficients, Low-level		$T_j = 175^\circ\text{C}, I = 15\% I_{T(av)}$ to $\pi I_{T(av)}$				
					$A_1 = 0.42150$	
					$B_1 = 0.01339$	
					$C_1 = 4.598\text{E-}05$	
					$D_1 = 0.007539$	
V_{TM} Coefficients, High-level		$T_j = 175^\circ\text{C}, I = \pi I_{T(av)}$ to I_{TSM}				
					$A_2 = -1.3173$	
					$B_2 = 0.30858$	
					$C_2 = 8.988\text{E-}05$	
					$D_2 = -0.006564$	
Maximum Reverse Recovery Charge	Q_{rr}	$T_j = 175^\circ\text{C}, I_{FM} = 1000\text{A},$ $di_R/dt = 25\text{A}/\mu\text{sec}, t_p = 1000\mu\text{sec}$			4000	μC

Thermal Characteristics

Maximum Thermal Resistance, Double Sided Cooling						
Junction-to-Case	$R_{\theta(j-c)}$				0.025	$^\circ\text{C}/\text{W}$
Case-to-Sink	$R_{\theta(c-s)}$				0.0075	$^\circ\text{C}/\text{W}$

Powerex, Inc., 200 Hillis Street, Youngwood, Pennsylvania 15697-1800 (412) 925-7272
 Powerex, Europe, S.A. 428 Avenue G. Durand, BP107, 72003 Le Mans, France (43) 41.14.14

A451
General Purpose Rectifier
 2500 Amperes Average, 2200 Volts

Maximum On-State Forward Voltage Drop
 ($T_j = 175^\circ\text{C}$)

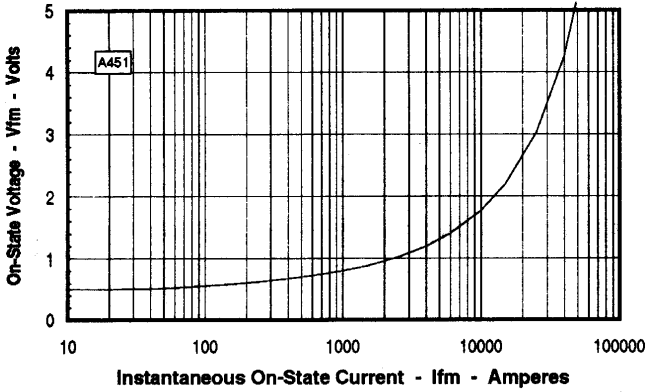

Maximum Transient Thermal Impedance
 (Junction to Case)

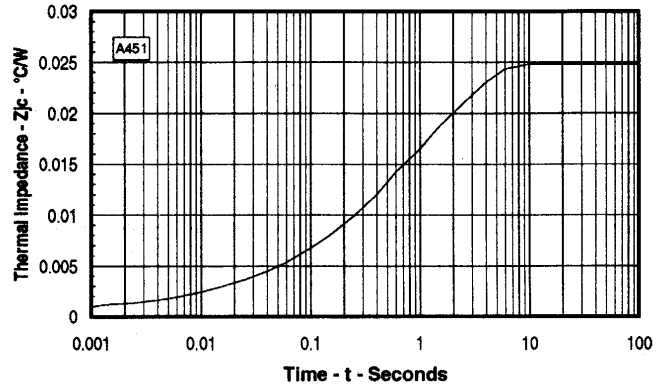

Maximum On-State Power Dissipation
 (Sinusoidal Waveform)

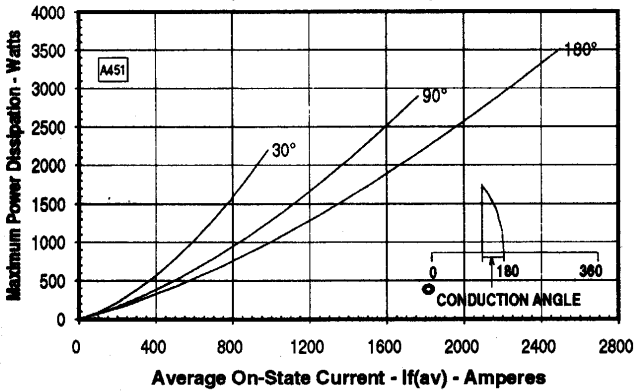

Maximum Allowable Case Temperature
 (Sinusoidal Waveform)

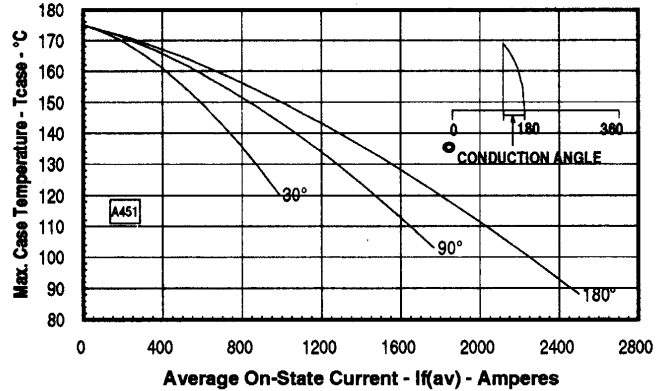

Maximum On-State Power Dissipation
 (Rectangular Waveform)

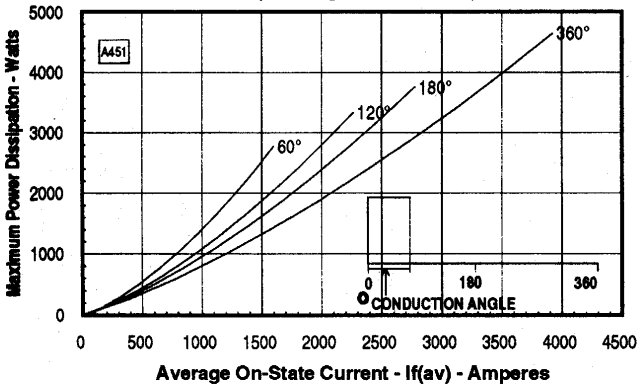

Maximum Allowable Case Temperature
 (Rectangular Waveform)

