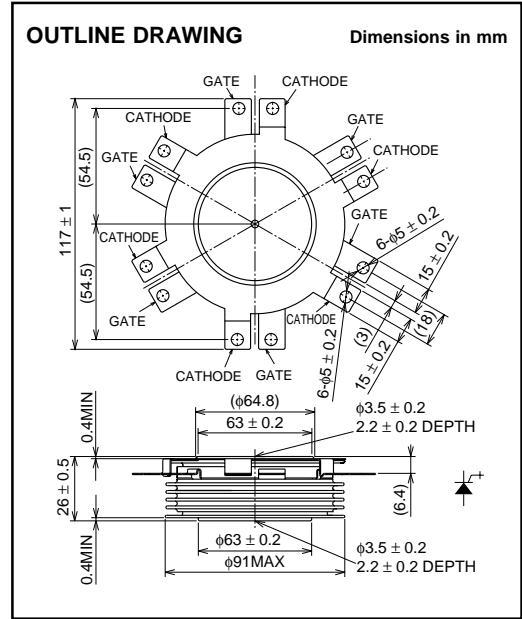
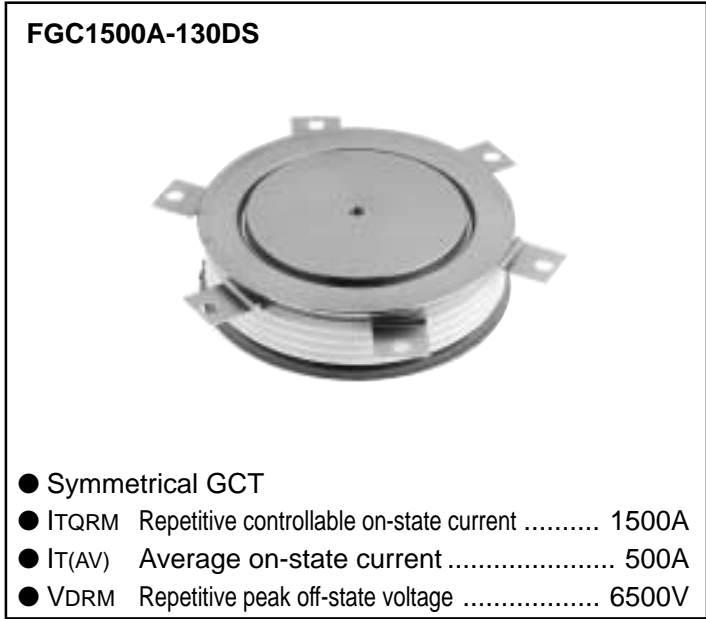


**PRELIMINARY**  
 Notice: This is not a final specification.  
 Some parametric limits are subject to change.

MITSUBISHI GATE COMMUTATED TURN-OFF THYRISTORS

**FGC1500A-130DS**

HIGH POWER INVERTER USE  
 PRESS PACK TYPE



**APPLICATION**

Inverters, DC choppers, Induction heaters, DC to DC converters.

**MAXIMUM RATINGS**

Symbol	Parameter	Conditions	Voltage class	Unit
VRRM	Repetitive peak reverse voltage	—	6500	V
VRSM	Non-repetitive peak reverse voltage	—	6500	V
VDRM	Repetitive peak off-state voltage	VGK = -2V	6500	V
VDSM	Non-repetitive peak off-state voltage	VGK = -2V	6500	V
VLTD5	Long term DC stability voltage	VGK = -2V, λ = 100 Fit	3600	V

Symbol	Parameter	Conditions	Ratings	Unit
ITQRM	Repetitive controllable on-state current	VDM = 3/4 VDRM, VD = 3000V, LC = 0.3μH, VRG = 20V Tj = 25/115°C, With GU-D15 (see Fig. 1, 3)	1500	A
IT(RMS)	RMS on-state current	Applied for all conduction angles	780	A
IT(AV)	Average on-state current	f = 60Hz, sinewave θ = 180°, Tr = 55°C	500	A
ITSM	Surge on-state current	One half cycle at 60Hz, Tj = 115°C Start	8	kA
I <sup>2</sup> t	Current-squared, time integration		2.7 × 10 <sup>5</sup>	A <sup>2</sup> s
diT/dt	Critical rate of rise of on-state current	VD = 3000V, IT = 1500A, Cs = 0.2μF, Rs = 5Ω Tj = 25/115°C, f = 60Hz, With GU-D15 (see Fig. 1,2)	1000	A/μs
VFGM	Peak forward gate voltage		10	V
VRGM	Peak reverse gate voltage		21	V
IFGM	Peak forward gate current		900	A
IRGM	Peak reverse gate current		1500	A
PFGM	Peak forward gate power dissipation		9	kW
PRGM	Peak reverse gate power dissipation		32	kW
PFG(AV)	Average forward gate power dissipation		180	W
PRG(AV)	Average reverse gate power dissipation		230	W
Tj	Junction temperature		-20 ~ +115	°C
Tstg	Storage temperature		-20 ~ +150	°C
—	Mounting force required	(Recommended value 20kN)	18 ~ 24	kN
—	Weight	Typical value	760	g

**PRELIMINARY**  
 Notice: This is not a final specification.  
 Some parametric limits are subject to change.

**FGC1500A-130DS**

**HIGH POWER INVERTER USE  
 PRESS PACK TYPE**

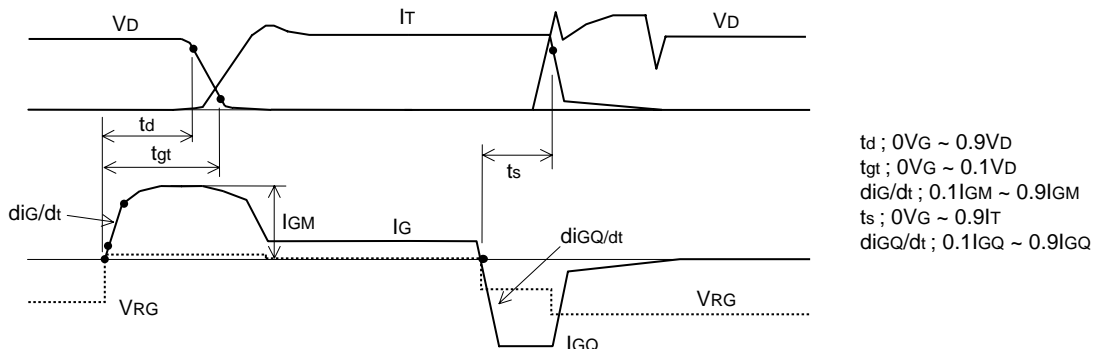
**ELECTRICAL CHARACTERISTICS**

Symbol	Parameter	Test conditions	Limits			Unit
			Min	Typ	Max	
V <sub>TM</sub>	On-state voltage	I <sub>T</sub> = 1500A, T <sub>j</sub> = 115°C	—	—	7.0	V
I <sub>RRM</sub>	Repetitive peak reverse current	V <sub>RM</sub> = 6500V, T <sub>j</sub> = 115°C	—	—	220	mA
I <sub>DRM</sub>	Repetitive peak off-state current	V <sub>DM</sub> = 6500V, V <sub>GK</sub> = -2V, T <sub>j</sub> = 115°C	—	—	150	mA
I <sub>GRM</sub>	Reverse gate current	V <sub>RG</sub> = 21V, T <sub>j</sub> = 115°C	—	—	100	mA
dv/dt	Critical rate of rise of off-state voltage	V <sub>D</sub> = 3000V, V <sub>GK</sub> = -2V, T <sub>j</sub> = 115°C (Expo. wave) (see Fig. 4)	3000	—	—	V/μs
t <sub>gt</sub>	Turn-on time	I <sub>T</sub> = 1500A, V <sub>D</sub> = 3000V, di/dt = 1000A/μs, T <sub>j</sub> = 115°C	—	—	5.0	μs
t <sub>d</sub>	Delay time	C <sub>s</sub> = 0.2μF, R <sub>s</sub> = 5Ω	—	—	1.0	μs
E <sub>on</sub>	Turn-on switching energy	With GU-D15 (see Fig. 1, 2)	—	—	2.15	J/P
t <sub>s</sub>	Storage time	I <sub>T</sub> = 1500A, V <sub>DM</sub> = 3/4 V <sub>DRM</sub> , V <sub>D</sub> = 3000V C <sub>s</sub> = 0.2μF, R <sub>s</sub> = 5Ω, V <sub>RG</sub> = 20V, T <sub>j</sub> = 115°C	—	—	3.0	μs
E <sub>off</sub>	Turn-off switching energy	With GU-D15 (see Fig. 1, 5)	—	—	12	J/P
Q <sub>RR</sub>	Reverse recovery charge	V <sub>R</sub> = 3000V, I <sub>T</sub> = 1500A, di/dt = 1000A/μs	—	—	2800	μC
E <sub>rec</sub>	Reverse recovery energy	C <sub>s</sub> = 0.2μF, R <sub>s</sub> = 5Ω, T <sub>j</sub> = 115°C (see Fig. 5, 6)	—	—	7	J/P
I <sub>GT</sub>	Gate trigger current	DC METHOD : V <sub>D</sub> = 24V, R <sub>L</sub> = 0.1Ω, T <sub>j</sub> = 25°C	—	—	0.75	A
V <sub>GT</sub>	Gate trigger voltage		—	—	1.5	V
R <sub>th(j-f)</sub>	Thermal resistance	Junction to fin	—	—	0.016	°C/W

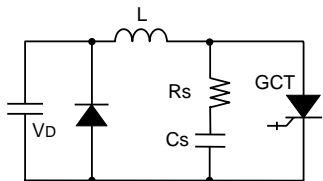
# FGC1500A-130DS

HIGH POWER INVERTER USE  
PRESS PACK TYPE

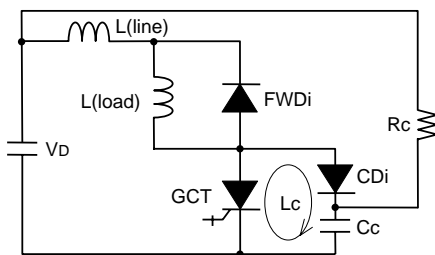
**Fig. 1 Turn-on and Turn-off waveform**



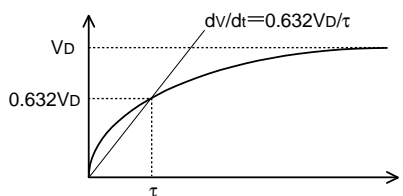
**Fig. 2 Turn-on test circuit**



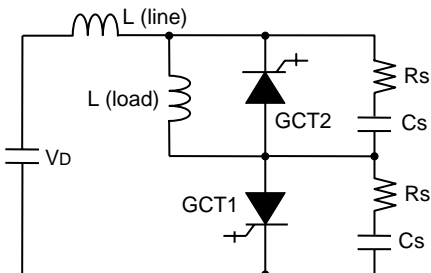
**Fig. 3 Turn-off test circuit (With clamp circuit)**



**Fig. 4 dv/dt test waveform**

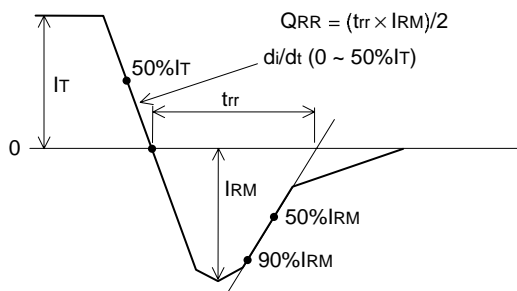


**Fig. 5 Turn-off and Recovery test circuit**



GCT1 : For turn-off test  
GCT2 : For Recovery test

**Fig. 6 Reverse recovery waveform**

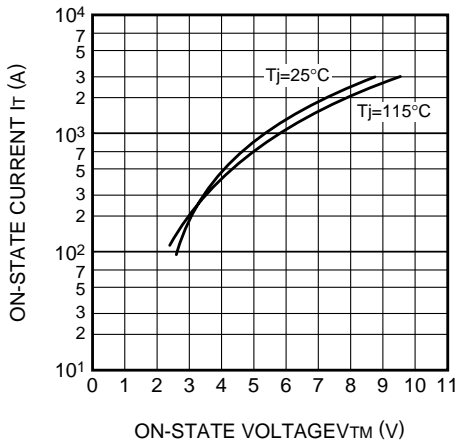


# FGC1500A-130DS

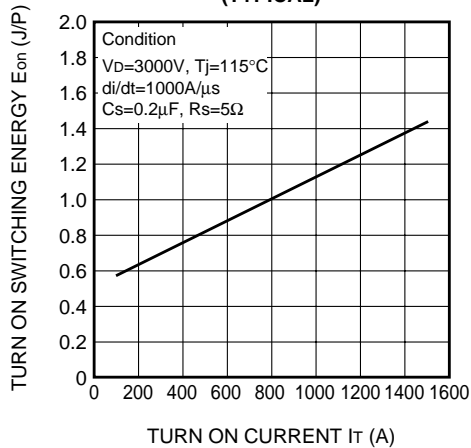
HIGH POWER INVERTER USE  
PRESS PACK TYPE

## PERFORMANCE CURVES

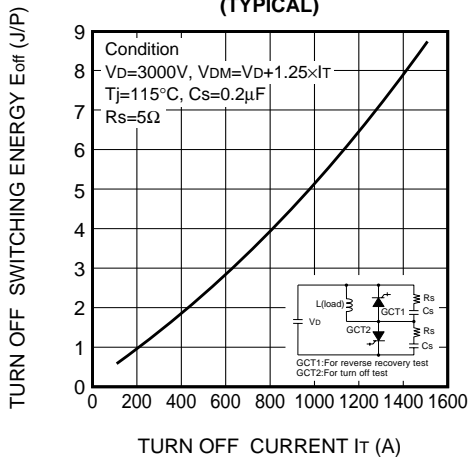
MAXIMUM ON-STATE CHARACTERISTIC



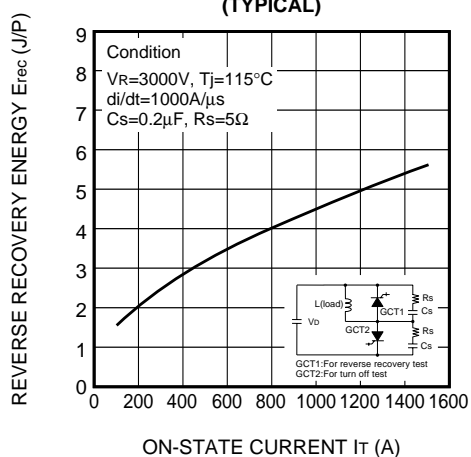
$E_{on}$  VS  $I_T$   
(TYPICAL)



$E_{off}$  VS  $I_T$   
(TYPICAL)



$E_{rec}$  VS  $I_T$   
(TYPICAL)



MAXIMUM THERMAL IMPEDANCE  
CHARACTERISTIC  
(JUNCTION TO FIN)

