

## 16-Pin Multiple Circuit Triac 0.8 Amperes/400-700 Volts

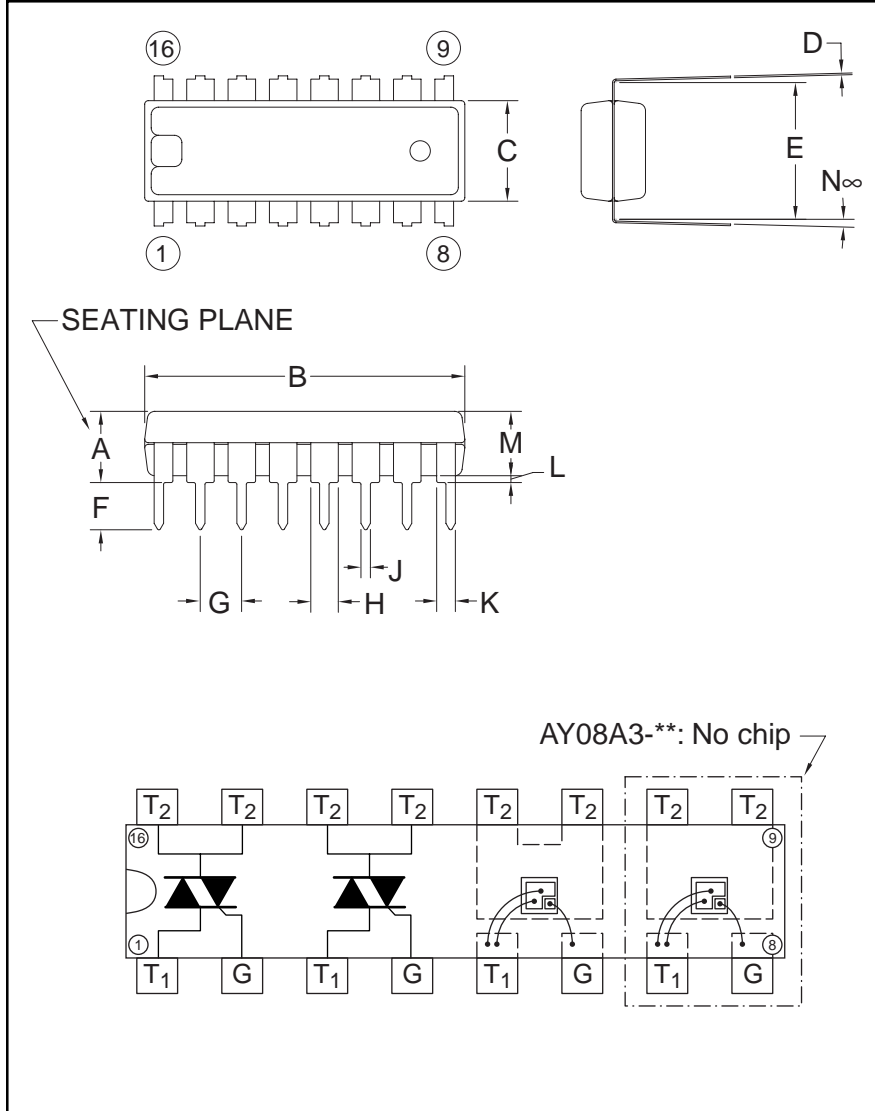

**Outline Drawing**

Dimension	Inches	Millimeters
A	1.8 Max.	4.5 Max.
B	0.75±0.01	19.0±0.2
C	0.25±0.01	6.3±0.15
D	0.01	0.27 +0.07/-0.05
E	0.3	7.62
F	0.12 Min.	3.0 Min.

Dimension	Inches	Millimeters
G	0.1	2.54
H	0.06 +0.01/-0	1.5 +0.3/-0.1
J	0.02	0.5±0.1
K	0.04 +0.01/-0	1.0 +0.3/-0.1
L	0.02 Min.	0.51 Min.
M	0.13	3.3

**Description:**

A triac is a solid state silicon AC switch which may be gate triggered from an off-state to an on-state for either polarity of applied voltage.

**Features:**

- Planar Passivation
- Surface Mount Type
- Multiple Circuits in one Package

**Applications:**

- Electric Fan
- Air Cleaner
- Small Motor Control

**Ordering Information:**

Example: Select the complete part number from the table below -i.e. AY08A4-14 is a 0.8 Ampere, 4 Circuit, 700V, 16-Pin Multiple Circuit Triac.

Type	Number of Circuits	Voltage (x 50)
AY08A	3	-8
	4	-12
		-14



Powerex, Inc., 200 Hillis Street, Youngwood, Pennsylvania 15697-1800 (724) 925-7272

AY08A3-\*\*

AY08A4-\*\*

16-Pin Multiple Circuit Triac

0.8 Amperes/400-700 Volts

### Absolute Maximum Ratings (for One Chip), $T_j = 25^\circ\text{C}$ unless otherwise specified

Characteristics	Symbol	AY08A*-08	AY08A*-12	AY08A*-14	Units
Repetitive Peak Off-state Voltage, Gate Open	$V_{\text{DRM}}$	400	600	700	Volts
Non-Repetitive Peak Off-state Voltage, Gate Open	$V_{\text{DSM}}$	500	720	840	Volts
On-state Current, $T_c = 86^\circ\text{C}$	$I_{\text{T(RMS)}}$	0.8	0.8	0.8	Amperes
Non-repetitive Peak Surge, One Cycle (60Hz)	$I_{\text{TSM}}$	8	8	8	Amperes
$I^2t$ for Fusing, $t = 8.3$ msec	$I^2t$	0.26	0.26	0.26	$\text{A}^2\text{sec}$
Peak Gate Power Dissipation, 20 msec	$P_{\text{GM}}$	1	1	1	Watts
Average Gate Power Dissipation	$P_{\text{G(avg)}}$	0.1	0.1	0.1	Watts
Peak Gate Current	$I_{\text{GM}}$	0.8	0.8	0.8	Amperes
Peak Gate Voltage	$V_{\text{GM}}$	6	6	6	Volts
Storage Temperature	$T_{\text{stg}}$	-40 to 125	-40 to 125	-40 to 125	$^\circ\text{C}$
Operating Temperature	$T_j$	-40 to 125	-40 to 125	-40 to 125	$^\circ\text{C}$

### Electrical and Thermal Characteristics (for One Chip), $T_j = 25^\circ\text{C}$ unless otherwise specified

Characteristics	Symbol	Test Conditions	Min.	Typ.	Max.	Units
Repetitive Off-state Current, Peak	$I_{\text{DRM}}$	$V_{\text{DRM}}$ applied, $T_j = 125^\circ\text{C}$	–	–	1.0	mA
Peak On-state Voltage	$V_{\text{TM}}$	$T_c = 25^\circ\text{C}$ , $I_{\text{TM}} = 1.2\text{A}$	–	–	2.0	Volts
<b>Thermal Resistance</b>						
Junction to Ambient	$R_{\text{th(j-a)}}$	–	–	–	120	$^\circ\text{C/Watt}$
<b>Gate — Parameters</b>						
Gate Current to Trigger II	$I_{\text{RGTII}}$	$T_j = 25^\circ\text{C}$ , $V_D = 6\text{V}$	–	–	5.0	mA
Gate Current to Trigger III	$I_{\text{RGTIII}}$	$R_L = 6\Omega$ , $R_G = 330\Omega$	–	–	5.0	mA
Gate Voltage to Trigger II	$V_{\text{RGTII}}$	$T_j = 25^\circ\text{C}$ , $V_D = 6\text{V}$	–	–	2.0	Volts
Gate Voltage to Trigger III	$V_{\text{RGTIII}}$	$R_L = 6\Omega$ , $R_G = 330\Omega$	–	–	2.0	Volts
Non-triggering Gate Voltage	$V_{\text{GD}}$	$T_j = 125^\circ\text{C}$ , $V_D = 1/2 V_{\text{DRM}}$	0.1	–	–	Volts
Critical Rate-of-Rise of Commutating	$(dv/dt)_c$	$T_j = 125^\circ\text{C}$	0.5	–	–	$\text{V}/\mu\text{s}$
Off-state Voltage		$(dv/dt)_c = -0.4\text{A/ms}$ , $V_D = 400\text{V}$				