

PACKAGE DIMENSIONS

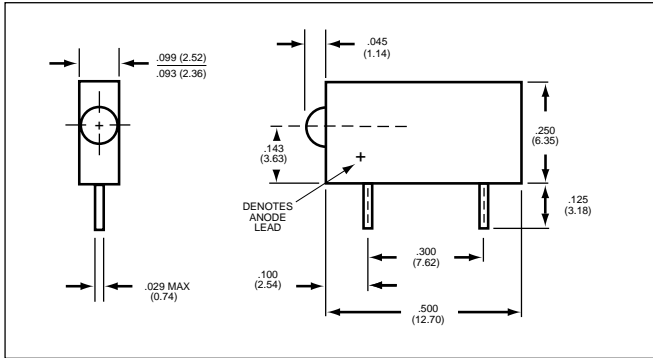

FIG. - 1

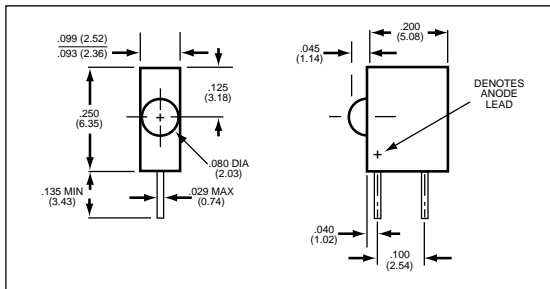

FIG. - 2

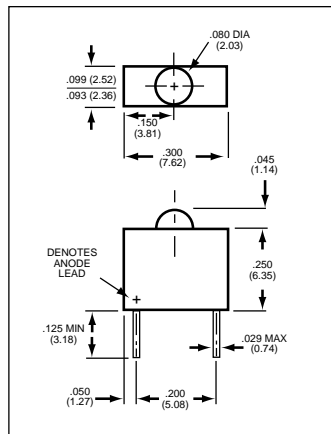

FIG. - 3

DESCRIPTION

For right-angle and vertical viewing, the QT Optoelectronics LED circuit board indicators come in T-3/4, T-1 and T-1 3/4 lamp sizes, and in single, dual and multiple packages. The indicators are available in AlGaAs red, high-efficiency red, bright red, green, yellow, and bi-color at standard drive currents, as well as at 2 mA drive current. To reduce component cost and save space, 5 V and 12 V types are available with integrated resistors. The LEDs are packaged in a black plastic housing for optical contrast, and the housing meets UL94V-0 flammability specifications.

T-3/4 (Subminiature)

PART NUMBER	COLOR	VF	mcd	@ mA	PKG. FIG.
MV5000.MP1	RED	1.7	3.0	20	1
MV5300.MP1	YLW	2.1	2.0	20	1
MV5400.MP1	GRN	2.3	3.5	20	1
MV5000.MP2	RED	1.7	3.0	20	2
MV5300.MP2	YLW	2.1	2.0	20	2
MV5400.MP2	GRN	2.3	3.5	20	2
MV5000.MP3	RED	1.7	3.0	20	3
MV5300.MP3	YLW	2.1	2.0	20	3
MV5400.MP3	GRN	2.3	3.5	20	3
INTEGRAL RESISTOR					
MR5000.MP1	RED	5.0	.6	3	1
MR5010.MP1	RED	5.0	1.2	6	1
MR5020.MP1	RED	5.0	2.0	16	1
MR5310.MP1	YLW	5.0	.6	5	1
MR5410.MP1	GRN	5.0	.5	5	1
MR5000.MP2	RED	5.0	.6	3	2
MR5010.MP2	RED	5.0	1.2	6	2
MR5020.MP2	RED	5.0	2.0	16	2
MR5310.MP2	YLW	5.0	.6	5	2
MR5410.MP2	GRN	5.0	.5	5	2
MR5000.MP3	RED	5.0	.6	3	3
MR5010.MP3	RED	5.0	1.2	6	3
MR5020.MP3	RED	5.0	2.0	16	3
MR5310.MP3	YLW	5.0	.6	5	3
MR5410.MP3	GRN	5.0	.5	5	3

GENERAL NOTES:

1. All dimensions are in inches (mm).
2. Tolerance is $\pm .015$ ($\pm .38$) unless otherwise specified.
3. All electrical values are typical.
4. All parts have colored *diffused* lens except those with an asterisk (*), which denotes colored *clear* lens.

PACKAGE DIMENSIONS

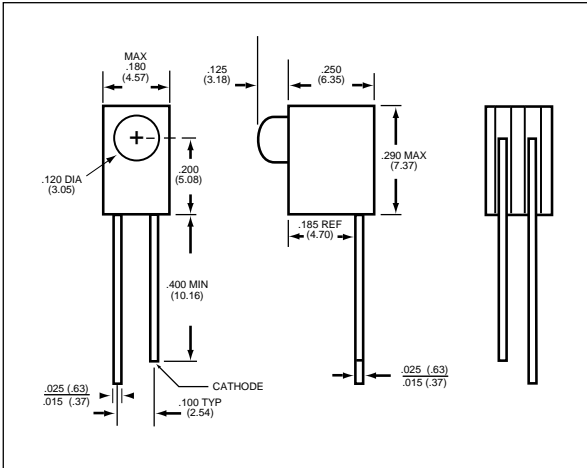

FIG. - 4A

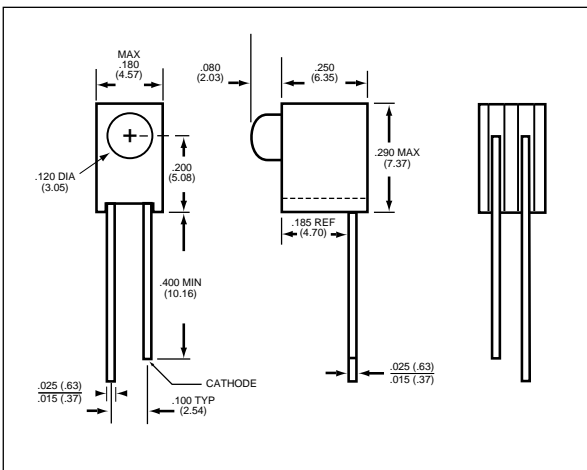

FIG. - 4B

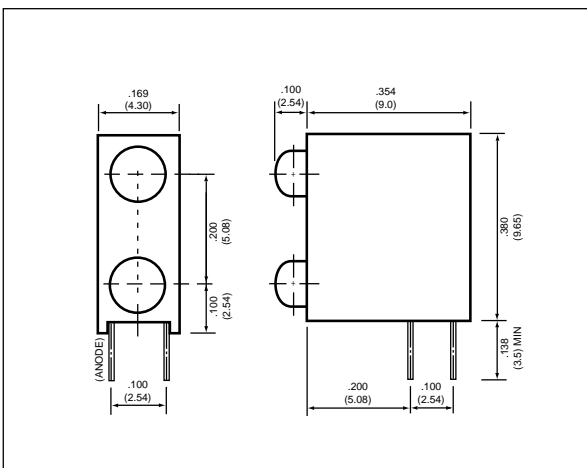

FIG. - 4C

T-1 (3mm)

PART NUMBER	COLOR	VF	mcd	@ mA	PKG. FIG.
MV5064.MP4A	RED	1.6	1.5	20	4A
MV5364.MP4A	YELLOW	2.1	2.0	10	4A
MV5464.MP4A	GREEN	2.2	5.0	20	4A
MV5764.MP4A	H-E RED	2.0	2.0	10	4A
MV5064.MP4B	RED	1.6	1.5	20	4B
MV5364.MP4B	YELLOW	2.1	2.0	10	4B
MV5464.MP4B	GREEN	2.2	5.0	20	4B
MV5764.MP4B	H-E RED	2.0	2.0	10	4B
LOW CURRENT (2mA)					
HLMP-1700.MP4A	H-E RED	1.8	2.0	2	4A
HLMP-1719.MP4A	YELLOW	1.9	2.0	2	4A
HLMP-1790.MP4A	GREEN	1.9	2.0	2	4A
HLMP-1700.MP4B	H-E RED	1.8	2.0	2	4B
HLMP-1719.MP4B	YELLOW	1.9	2.0	2	4B
HLMP-1790.MP4B	GREEN	1.9	2.0	2	4B
AlGaAs RED					
HLMP-K101.MP4A	AlGaAs RED	1.8	45.0	20	4A
HLMP-K105.MP4A	AlGaAs RED*	1.8	65.0	20	4A
HLMP-K150.MP4A	AlGaAs RED	1.6	2.0	1	4A
HLMP-K155.MP4A	AlGaAs RED*	1.6	3.0	1	4A
HLMP-K101.MP4B	AlGaAs RED	1.8	45.0	20	4B
HLMP-K105.MP4B	AlGaAs RED*	1.8	65.0	20	4B
HLMP-K150.MP4B	AlGaAs RED	1.6	2.0	1	4B
HLMP-K155.MP4B	AlGaAs RED*	1.6	3.0	1	4B
INTEGRAL RESISTOR					
MR5060.MP4A	RED	5.0	1.5	13	4A
MR5360.MP4A	YELLOW	5.0	4.0	10	4A
MR5460.MP4A	GREEN	5.0	4.0	12	4A
MR5760.MP4A	H-E RED	5.0	4.0	10	4A
MR5060.MP4B	RED	5.0	1.5	13	4B
MR5360.MP4B	YELLOW	5.0	4.0	10	4B
MR5460.MP4B	GREEN	5.0	4.0	12	4B
MR5760.MP4B	H-E RED	5.0	4.0	10	4B

T-1 (3mm) bilevel

PART NUMBER	COLOR	VF	mcd	@ mA	PKG. FIG.
QLA694B-2H	B. RED/B. RED	2.1	1.4	10	4C
QLA694B-2I	H-E RED/H-E RED	2.0	6.0	10	4C
QLA694B-2G	GRN/GRN	2.1	6.0	10	4C
QLA694B-2Y	YEL/YEL	2.0	6.0	10	4C
QLA694B-HG	B. RED/GRN	2.1	1.4	10	4C
QLA694B-GY	GRN/YEL	2.1	6.0	10	4C

First color indicated is on top, and the second color is on the bottom.
For example: QLA694B-GY has GRN(top)/YEL(bottom).

GENERAL NOTES:

1. All dimensions are in inches (mm).
2. Tolerance is $\pm .015$ ($\pm .38$) unless otherwise specified.
3. All electrical values are typical.
4. All parts have colored *diffused* lens except those with an asterik (*), which denotes colored *clear* lens.
5. Custom color combinations are available.

PACKAGE DIMENSIONS

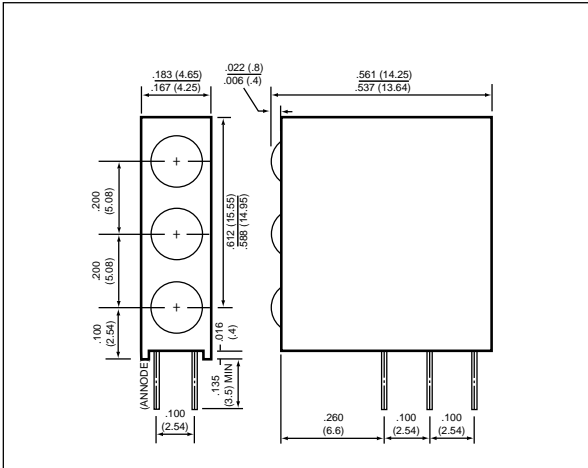

FIG. - 4D

T-1 (3mm) trilevel

PART NUMBER	COLOR	VF	mcd	@ mA	PKG. FIG.
QLA764B-3H	B. RED	2.1	1.4	10	4D
QLA764B-3I	H-E RED	2.0	6.0	10	4D
QLA764B-3G	GRN	2.1	6.0	10	4D
QLA764B-3Y	YEL	2.0	6.0	10	4D
QLA764B-HGY	B. RED/GRN/YEL	2.1	1.4	10	4D
QLA764B-YGH	YEL/GRN/B. RED	2.1	1.4	10	4D

First color indicated is on top, the second is in the middle, and the third is on the bottom. For example: QLA764B-YGH has YEL(top)/GRN(middle)/B. RED(bottom).

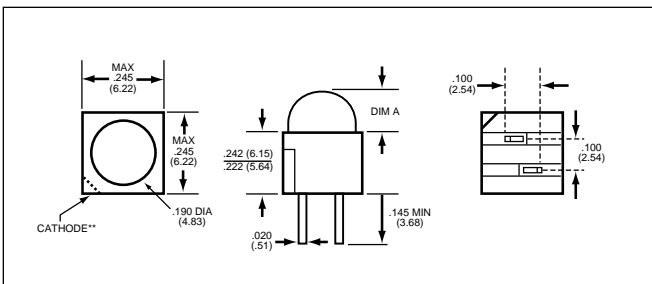

FIG. - 5

T-1 3/4 (5mm)

PART NUMBER	COLOR	VF	mcd	@ mA	DIM A in. (mm)	PKG. FIG.
MV60538.MP5	RED	1.7	2.0	20	.125 (3.18)	5
MV63538.MP5	YLW	2.1	18.0	20	.125 (3.18)	5
MV64538.MP5	GRN	2.2	26.0	20	.125 (3.18)	5
MV67538.MP5	H-E RED	2.1	14.0	20	.125 (3.18)	5
MV60539.MP5	RED	1.7	3.2	20	.180 (4.57)	5
MV63539.MP5	YLW	2.1	20.0	20	.180 (4.57)	5
MV64539.MP5	GRN	2.2	28.0	20	.180 (4.57)	5
MV67539.MP5	H-E RED	2.1	15.0	20	.180 (4.57)	5
LOW CURRENT (2mA)						
HLMP-47009.MP5	H-E RED	1.8	2.0	2	.180 (4.57)	5
HLMP-47199.MP5	YLW	1.9	2.0	2	.180 (4.57)	5
HLMP-47409.MP5	GRN	1.9	3.0	2	.180 (4.57)	5
AlGaAs RED						
HLMP-D1019.MP5	AlGaAs RED	1.8	70.0	20	.180 (4.57)	5
HLMP-D1509.MP5	AlGaAs RED	1.6	3.0	1	.180 (4.57)	5
ULTRA BRIGHT						
MV33509.MP5	YLW*	2.2	150.0	20	.180 (4.57)	5
MV34509.MP5	GRN*	2.2	150.0	20	.180 (4.57)	5
MV37509.MP5	H-E RED*	2.2	150.0	20	.180 (4.57)	5
INTEGRAL RESISTOR						
MR30509.MP5	RED	5.0	2.0	13	.180 (4.57)	5
MR30519.MP5	RED	12.0	2.0	13	.180 (4.57)	5
MR33509.MP5	YLW	5.0	4.0	10	.180 (4.57)	5
MR33519.MP5	YLW	12.0	4.0	13	.180 (4.57)	5
MR34509.MP5	GRN	5.0	4.0	12	.180 (4.57)	5
MR34519.MP5	GRN	12.0	4.0	13	.180 (4.57)	5
MR37509.MP5	H-E RED	5.0	4.0	10	.180 (4.57)	5
MR37519.MP5	H-E RED	12.0	4.0	13	.180 (4.57)	5
BICOLOR**						
MV54919.MP5	RED/GRN	2.3	6.0	20	.180 (4.57)	5

GENERAL NOTES:

1. All dimensions are in inches (mm).
2. Tolerance is $\pm .015$ ($\pm .38$) unless otherwise specified.
3. All electrical values are typical.
4. All parts have colored *diffused* lens except those with an asterisk (*), which denotes colored *clear* lens.
5. A double asterisk (**) denotes that the cathode, as indicated, is the red cathode for the RED/GRN bicolor LED.
6. Custom color combinations are available.

PACKAGE DIMENSIONS

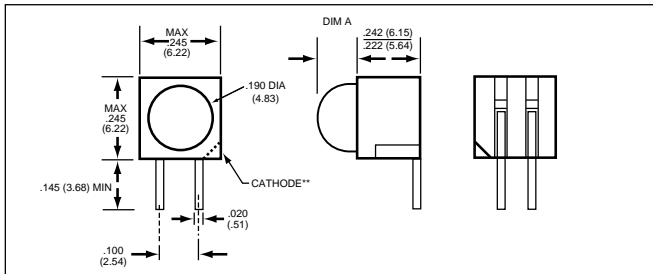

FIG. - 6

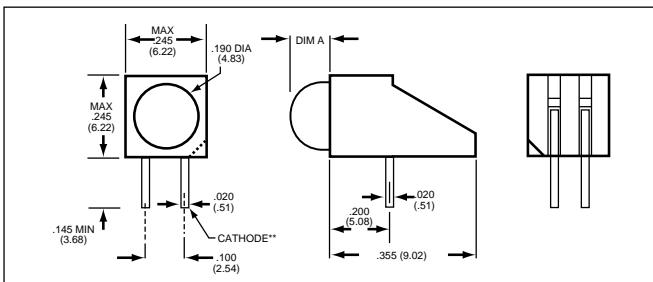

FIG. - 7

GENERAL NOTES:

1. All dimensions are in inches (mm).
2. Tolerance is $\pm .015$ ($\pm .38$) unless otherwise specified.
3. All electrical values are typical.
4. All parts have colored *diffused* lens except those with an asterik (*), which denotes colored *clear* lens.
5. A double asterik (**) denotes that the cathode, as indicated, is the red cathode for the RED/GRN bicolor LED.
6. Custom color combinations are available.

T-1 3/4 (5mm)

PART NUMBER	COLOR	VF	mcd	@	DIM A	PKG.
				mA	in. (mm)	FIG.
MV60538.MP6	RED	1.7	2.0	20	.125 (3.18)	6
MV63538.MP6	YLW	2.1	18.0	20	.125 (3.18)	6
MV64538.MP6	GRN	2.2	26.0	20	.125 (3.18)	6
MV67538.MP6	H-E RED	2.1	14.0	20	.125 (3.18)	6
MV60539.MP6	RED	1.7	3.2	20	.180 (4.57)	6
MV63539.MP6	YLW	2.1	20.0	20	.180 (4.57)	6
MV64539.MP6	GRN	2.2	28.0	20	.180 (4.57)	6
MV67539.MP6	H-E RED	2.1	15.0	20	.180 (4.57)	6
LOW CURRENT (2mA)						
HLMP-47009.MP6	H-E RED	1.8	2.0	2	.180 (4.57)	6
HLMP-47199.MP6	YLW	1.9	2.0	2	.180 (4.57)	6
HLMP-47409.MP6	GRN	1.9	3.0	2	.180 (4.57)	6
AlGaAs RED						
HLMP-D1019.MP6	AlGaAs RED	1.8	70.0	20	.180 (4.57)	6
HLMP-D1509.MP6	AlGaAs RED	1.6	3.0	1	.180 (4.57)	6
ULTRA BRIGHT						
MV33509.MP6	YLW*	2.2	150.0	20	.180 (4.57)	6
MV34509.MP6	GRN*	2.2	150.0	20	.180 (4.57)	6
MV37509.MP6	H-E RED*	2.2	150.0	20	.180 (4.57)	6
INTEGRAL RESISTOR						
MR30509.MP6	RED	5.0	2.0	13	.180 (4.57)	6
MR30519.MP6	RED	12.0	2.0	13	.180 (4.57)	6
MR33509.MP6	YLW	5.0	4.0	10	.180 (4.57)	6
MR33519.MP6	YLW	12.0	4.0	13	.180 (4.57)	6
MR34509.MP6	GRN	5.0	4.0	12	.180 (4.57)	6
MR34519.MP6	GRN	12.0	4.0	13	.180 (4.57)	6
MR37509.MP6	H-E RED	5.0	4.0	10	.180 (4.57)	6
MR37519.MP6	H-E RED	12.0	4.0	13	.180 (4.57)	6
BICOLOR**						
MV54919.MP6	RED/GRN	2.3	6.0	20	.180 (4.57)	6

T-1 3/4 (5mm)

PART NUMBER	COLOR	VF	mcd	@	DIM A	PKG.
				mA	in. (mm)	FIG.
MV60538.MP7	RED	1.7	2.0	20	.125 (3.18)	7
MV63538.MP7	YLW	2.1	18.0	20	.125 (3.18)	7
MV64538.MP7	GRN	2.2	26.0	20	.125 (3.18)	7
MV67538.MP7	H-E RED	2.1	14.0	20	.125 (3.18)	7
MV60539.MP7	RED	1.7	3.2	20	.183 (4.65)	7
MV63539.MP7	YLW	2.1	20.0	20	.183 (4.65)	7
MV64539.MP7	GRN	2.2	28.0	20	.183 (4.65)	7
MV67539.MP7	H-E RED	2.1	15.0	20	.183 (4.65)	7
LOW CURRENT (2mA)						
HLMP-47009.MP7	H-E RED	1.8	2.0	2	.183 (4.65)	7
HLMP-47199.MP7	YLW	1.9	2.0	2	.183 (4.65)	7
HLMP-47409.MP7	GRN	1.9	3.0	2	.183 (4.65)	7
AlGaAs RED						
HLMP-D1019.MP7	AlGaAs RED	1.8	70.0	20	.183 (4.65)	7
HLMP-D1509.MP7	AlGaAs RED	1.6	3.0	1	.183 (4.65)	7
ULTRA BRIGHT						
MV33509.MP7	YLW*	2.2	150.0	20	.183 (4.65)	7
MV34509.MP7	GRN*	2.2	150.0	20	.183 (4.65)	7
MV37509.MP7	H-E RED*	2.2	150.0	20	.183 (4.65)	7
INTEGRAL RESISTOR						
MR30509.MP7	RED	5.0	2.0	13	.183 (4.65)	7
MR30519.MP7	RED	12.0	2.0	13	.183 (4.65)	7
MR33509.MP7	YLW	5.0	4.0	10	.183 (4.65)	7
MR33519.MP7	YLW	12.0	4.0	13	.183 (4.65)	7
MR34509.MP7	GRN	5.0	4.0	12	.183 (4.65)	7
MR34519.MP7	GRN	12.0	4.0	13	.183 (4.65)	7
MR37509.MP7	H-E RED	5.0	4.0	10	.183 (4.65)	7
MR37519.MP7	H-E RED	12.0	4.0	13	.183 (4.65)	7
BICOLOR**						
MV54919.MP7	RED/GRN	2.3	6.0	20	.183 (4.65)	7

PACKAGE DIMENSIONS

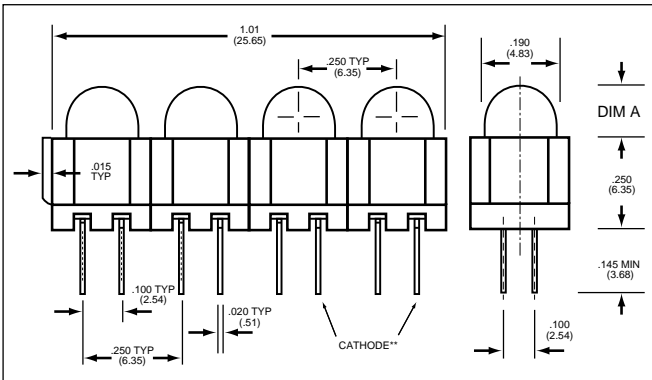

FIG. - 8

SPECIFIC NOTES:

For T-1 3/4 (5mm) multiple, multiples of four is the standard configuration.

Options — To obtain units in multiples of two add a "-2" suffix to the part number (i.e. MV64539.MP8-2). To obtain units in multiples of three add a "-3" suffix.

T-1 3/4 (5mm) multiple

PART NUMBER	COLOR	VF	mcd	@ mA	DIM A in. (mm)	PKG. FIG.
MV60538.MP8	RED	1.7	2.0	20	.140 (3.56)	8
MV63538.MP8	YLW	2.1	18.0	20	.140 (3.56)	8
MV64538.MP8	GRN	2.2	26.0	20	.140 (3.56)	8
MV67538.MP8	H-E RED	2.1	14.0	20	.140 (3.56)	8
MV60539.MP8	RED	1.7	3.2	20	.195 (4.95)	8
MV63539.MP8	YLW	2.1	20.0	20	.195 (4.95)	8
MV64539.MP8	GRN	2.2	28.0	20	.195 (4.95)	8
MV67539.MP8	H-E RED	2.1	15.0	20	.195 (4.95)	8
LOW CURRENT (2mA)						
HLMP-47009.MP8	H-E RED	1.8	2.0	2	.195 (4.95)	8
HLMP-47199.MP8	YLW	1.9	2.0	2	.195 (4.95)	8
HLMP-47409.MP8	GRN	1.9	3.0	2	.195 (4.95)	8
ULTRA BRIGHT						
MV33509.MP8	YLW*	2.2	150.0	20	.195 (4.95)	8
MV34509.MP8	GRN*	2.2	150.0	20	.195 (4.95)	8
MV37509.MP8	H-E RED*	2.2	150.0	20	.195 (4.95)	8
INTEGRAL RESISTOR						
MR30509.MP8	RED	5.0	2.0	13	.195 (4.95)	8
MR30519.MP8	RED	12.0	2.0	13	.195 (4.95)	8
MR33509.MP8	YLW	5.0	4.0	10	.195 (4.95)	8
MR33519.MP8	YLW	12.0	4.0	13	.195 (4.95)	8
MR34509.MP8	GRN	5.0	4.0	12	.195 (4.95)	8
MR34519.MP8	GRN	12.0	4.0	13	.195 (4.95)	8
MR37509.MP8	H-E RED	5.0	4.0	10	.195 (4.95)	8
MR37519.MP8	H-E RED	12.0	4.0	13	.195 (4.95)	8
BICOLOR**						
MV54919.MP8	RED/GRN	2.3	6.0	20	.195 (4.95)	8

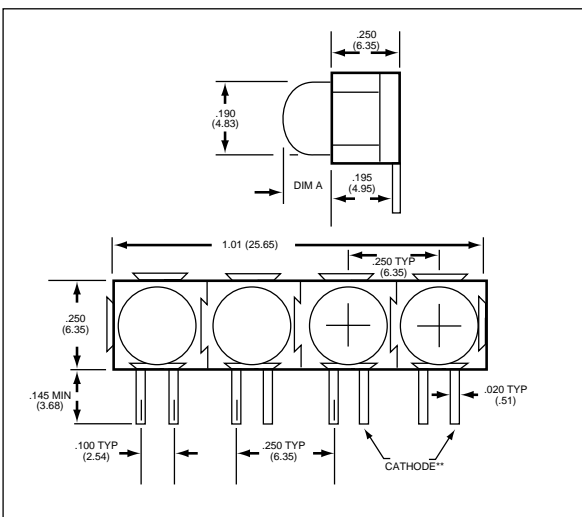

FIG. - 8A

GENERAL NOTES:

- All dimensions are in inches (mm).
- Tolerance is $\pm .015$ ($\pm .38$) unless otherwise specified.
- All electrical values are typical.
- All parts have colored *diffused* lens except those with an asterik (*), which denotes colored *clear* lens.
- A double asterik (**) denotes that the cathode, as indicated, is the red cathode for the RED/GRN bicolor LED.
- Custom color combinations are available.

T-1 3/4 (5mm) multiple

PART NUMBER	COLOR	VF	mcd	@ mA	DIM A in. (mm)	PKG. FIG.
MV60538.MP8A	RED	1.7	2.0	20	.140 (3.56)	8A
MV63538.MP8A	YLW	2.1	18.0	20	.140 (3.56)	8A
MV64538.MP8A	GRN	2.2	26.0	20	.140 (3.56)	8A
MV67538.MP8A	H-E RED	2.1	14.0	20	.140 (3.56)	8A
MV60539.MP8A	RED	1.7	3.2	20	.195 (4.95)	8A
MV63539.MP8A	YLW	2.1	20.0	20	.195 (4.95)	8A
MV64539.MP8A	GRN	2.2	28.0	20	.195 (4.95)	8A
MV67539.MP8A	H-E RED	2.1	15.0	20	.195 (4.95)	8A
LOW CURRENT (2mA)						
HLMP-47009.MP8A	H-E RED	1.8	2.0	2	.195 (4.95)	8A
HLMP-47199.MP8A	YLW	1.9	2.0	2	.195 (4.95)	8A
HLMP-47409.MP8A	GRN	1.9	3.0	2	.195 (4.95)	8A
ULTRA BRIGHT						
MV33509.MP8A	YLW*	2.2	150.0	20	.195 (4.95)	8A
MV34509.MP8A	GRN*	2.2	150.0	20	.195 (4.95)	8A
MV37509.MP8A	H-E RED*	2.2	150.0	20	.195 (4.95)	8A
INTEGRAL RESISTOR						
MR30509.MP8A	RED	5.0	2.0	13	.195 (4.95)	8A
MR30519.MP8A	RED	12.0	2.0	13	.195 (4.95)	8A
MR33509.MP8A	YLW	5.0	4.0	10	.195 (4.95)	8A
MR33519.MP8A	YLW	12.0	4.0	13	.195 (4.95)	8A
MR34509.MP8A	GRN	5.0	4.0	12	.195 (4.95)	8A
MR34519.MP8A	GRN	12.0	4.0	13	.195 (4.95)	8A
MR37509.MP8A	H-E RED	5.0	4.0	10	.195 (4.95)	8A
MR37519.MP8A	H-E RED	12.0	4.0	13	.195 (4.95)	8A
BICOLOR**						
MV54919.MP8A	RED/GRN	2.3	6.0	20	.195 (4.95)	8A

PACKAGE DIMENSIONS

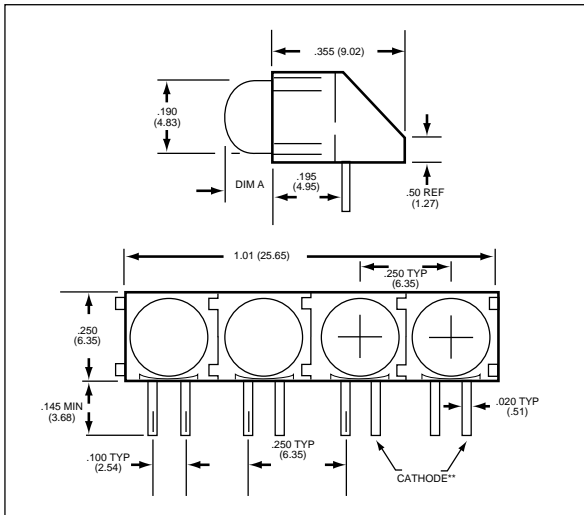

FIG. - 8B

SPECIFIC NOTES:

For T-1 3/4 (5mm) multiple, multiples of four is the standard configuration.

Options — To obtain units in multiples of two add a "-2" suffix to the part number (i.e. MV64539.MP8-2). To obtain units in multiples of three add a "-3" suffix.

T-1 3/4 (5mm) multiple

PART NUMBER	COLOR	VF	mcd	@ mA	DIM A in. (mm)	PKG. FIG.
MV60538.MP8B	RED	1.7	2.0	20	.140 (3.56)	8B
MV63538.MP8B	YLW	2.1	18.0	20	.140 (3.56)	8B
MV64538.MP8B	GRN	2.2	26.0	20	.140 (3.56)	8B
MV67538.MP8B	H-E RED	2.1	14.0	20	.140 (3.56)	8B
MV60539.MP8B	RED	1.7	3.2	20	.195 (4.95)	8B
MV63539.MP8B	YLW	2.1	20.0	20	.195 (4.95)	8B
MV64539.MP8B	GRN	2.2	28.0	20	.195 (4.95)	8B
MV67539.MP8B	H-E RED	2.1	15.0	20	.195 (4.95)	8B
LOW CURRENT (2mA)						
HLMP-47009.MP8B	H-E RED	1.8	2.0	2	.195 (4.95)	8B
HLMP-47199.MP8B	YLW	1.9	2.0	2	.195 (4.95)	8B
HLMP-47409.MP8B	GRN	1.9	3.0	2	.195 (4.95)	8B
ULTRA BRIGHT						
MV33509.MP8B	YLW*	2.2	150.0	20	.195 (4.95)	8B
MV34509.MP8B	GRN*	2.2	150.0	20	.195 (4.95)	8B
MV37509.MP8B	H-E RED*	2.2	150.0	20	.195 (4.95)	8B
INTEGRAL RESISTOR						
MR30509.MP8B	RED	5.0	2.0	13	.195 (4.95)	8B
MR30519.MP8B	RED	12.0	2.0	13	.195 (4.95)	8B
MR33509.MP8B	YLW	5.0	4.0	10	.195 (4.95)	8B
MR33519.MP8B	YLW	12.0	4.0	13	.195 (4.95)	8B
MR34509.MP8B	GRN	5.0	4.0	12	.195 (4.95)	8B
MR34519.MP8B	GRN	12.0	4.0	13	.195 (4.95)	8B
MR37509.MP8B	H-E RED	5.0	4.0	10	.195 (4.95)	8B
MR37519.MP8B	H-E RED	12.0	4.0	13	.195 (4.95)	8B
BICOLOR**						
MV54919.MP8B	RED/GRN	2.3	6.0	20	.195 (4.95)	8B

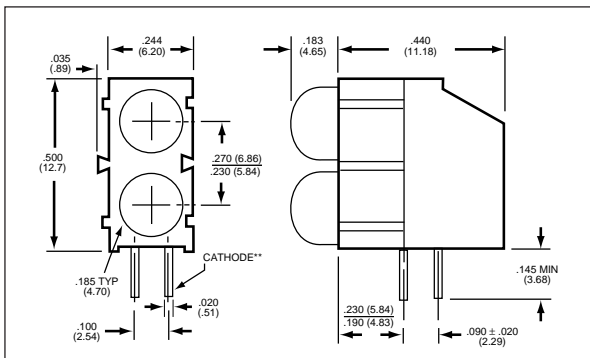

FIG. - 9
Parts are stackable

GENERAL NOTES:

- All dimensions are in inches (mm).
- Tolerance is $\pm .015$ ($\pm .38$) unless otherwise specified.
- All electrical values are typical.
- All parts have colored *diffused* lens except those with an asterik (*), which denotes colored *clear* lens.
- A double asterik (**) denotes that the cathode, as indicated, is the red cathode for the RED/GRN bicolor LED.
- Custom color combinations are available.

T-1 3/4 (5 mm) bilevel

PART NUMBER	COLOR	VF	mcd	@ mA	PKG. FIG.
MV60539.MP90	RED/RED	1.7	3.2	20	9
MV63539.MP93	YLW/YLW	2.1	20.0	20	9
MV64539.MP94	GRN/GRN	2.2	28.0	20	9
MV67539.MP97	H-E RED/H-E RED	2.1	15.0	20	9
LOW CURRENT (2mA)					
HLMP-47009.MP97	H-E RED/H-E RED	1.8	2.0	2	9
HLMP-47199.MP93	YLW/YLW	1.9	2.0	2	9
HLMP-47409.MP94	GRN/GRN	1.9	3.0	2	9
ULTRA BRIGHT					
MV33509.MP93	YLW/YLW*	2.2	150.0	20	9
MV34509.MP94	GRN/GRN*	2.2	150.0	20	9
MV37509.MP97	H-E RED/H-E RED*	2.2	150.0	20	9
INTEGRAL RESISTOR					
MR30509.MP90	RED/RED	5.0	2.0	13	9
MR33509.MP93	YLW/YLW	5.0	4.0	10	9
MR34509.MP94	GRN/GRN	5.0	4.0	12	9
MR37509.MP97	H-E RED/H-E RED	5.0	4.0	10	9
BICOLOR**					
MV54919.MP91	R/G/R/G	2.3	6.0	20	9

Call QT Optoelectronics for more information or the phone number of your nearest distributor.

United States 800-533-6786 ■ France 33 01/43.99.25.12 ■ Germany 49 089/96.30.51 ■ United Kingdom 44 01296/39.44.99 ■ Asia/Pacific 603/735-2417