

**SUBMINIATURE T-3/4  
5 - VOLT RESISTOR LAMPS**

**HIGH EFFICIENCY RED HLMP-6600/20  
YELLOW HLMP-6700/20  
HIGH EFFICIENCY GREEN HLMP-6800/20**

**PACKAGE DIMENSIONS**

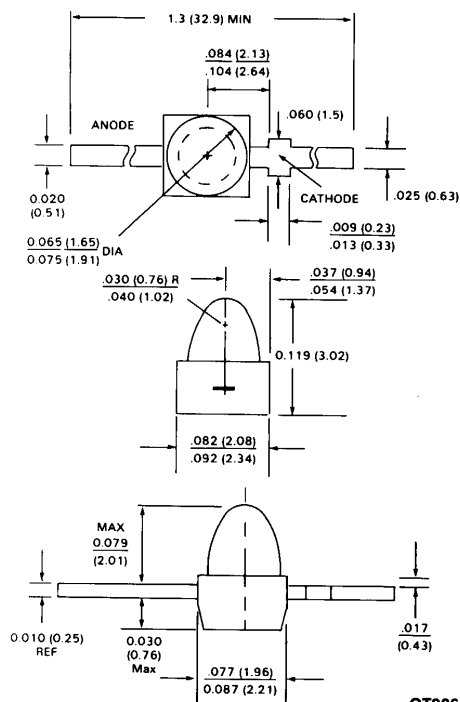

QT906A

**NOTES:**

1. ALL DIMENSIONS IN INCHES (mm)
2. TOLERANCE ARE  $\pm .010$  INCH UNLESS OTHERWISE SPECIFIED

**DESCRIPTION**

These T-3/4 square based LEDs contain an integral resistor which is in series with the emitter chip. This construction allows for the operation in circuits with 5V supply voltage; without the use of an external resistor. Color tinted, diffused epoxy packages are used for these lamps.

**FEATURES**

- Integral current limiting resistor.
- TTL compatible
- Wide viewing angle
- Solid-state reliability
- SMT lead formings and T&R available

**ABSOLUTE MAXIMUM RATING ( $T_A = 25^\circ\text{C}$  unless otherwise specified)**

PARAMETER	HER	YELLOW	GREEN	UNITS
Power dissipation	135	85	135	mW
DC forward voltage	6	6	6	V
Lead soldering time at	3	3	3	Sec
Surface mount reflow soldering				
Convective IR at 235°C				90 Seconds
Vapour phase at 213°C				3 Minutes
Operating temperature range				-40°C to 85°C
Storage temperature range				-55°C to 100°C

**TYPICAL THERMAL CHARACTERISTICS**

Thermal resistance $\theta_{JA}$	120°C/W
----------------------------------	---------

<b>ELECTRO-OPTICAL CHARACTERISTICS</b> ( $T_A = 25^\circ\text{C}$ Unless Otherwise Specified)					
PARAMETER	MIN.	TYP.	MAX.	UNITS	TEST CONDITIONS
Forward current - $I_f$					
HLMP-6600/6700/6800		9.6	13.0	mA	$V_f = 5\text{ V}$
HLMP-6620/6720/6820		3.5	5.0	mA	$V_f = 5\text{ V}$
Reverse voltage - $V_r$	5	30		V	$I_f = 100\mu\text{A}$
Viewing angle - $2\theta$		90		Degree	
Luminous intensity - $I_v$					
HLMP-6600/6700/6800	1.3	5.0		mcd	$V_f = 5\text{ V}$
HLMP-6620/6720/6820	0.8	2.0		mcd	$V_f = 5\text{ V}$
Peak wavelength					
HLMP-6600/20		635		nm	
HLMP-6700/20		583		nm	
HLMP-6800/20		565		nm	
Dominant wavelength					
HLMP-6600/20		626		nm	
HLMP-6700/20		585		nm	
HLMP-6800/20		569		nm	
Spectral line half-width					
HLMP-6600/20		40		nm	
HLMP-6700/20		36		nm	
HLMP-6800/20		28		nm	
Capacitance - C					
HLMP-6600/20		11		pF	$V_f = , F = 1\text{ MHz}$
HLMP-6700/20		15		pF	$V_f = , F = 1\text{ MHz}$
HLMP-6800/20		18		pF	$V_f = , F = 1\text{ MHz}$

