

HIGH EFFICIENCY RED
YELLOW

QTLP670C-2
QTLP670C-3

GREEN
AlGaAs RED

QTLP670C-4
QTLP670C-7

PACKAGE DIMENSIONS

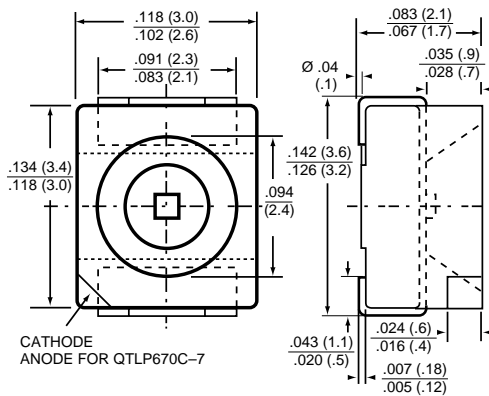

NOTE: ALL DIMENSIONS ARE IN INCHES (mm)

DESCRIPTION

The QT Optoelectronics surface mount lamps are designed with a flat top and sides for automatic placement equipment. They are compatible with convective IR and vapor phase reflow soldering and conductive epoxy attachment process.

The package size and configuration conform to the EIA-535 BAAC standard specification for case 3528 tantalum capacitor.

FEATURES

- Non-diffused package for backlighting and coupling to light pipe
- Low package profile
- Low power dissipation
- Wide viewing angle

ABSOLUTE MAXIMUM RATINGS ($T_A = 25^\circ\text{C}$ Unless otherwise specified)

QTLP	HER 670C-2	Yellow 670C-3	Green 670C-4	AlGaAs Red 670C-7	Units
DC forward current, I_F	30	20	30	30	mA
Operating temperature range	-40° C to +85° C				
Storage temperature range	-40° C to +100° C				
Lead soldering time	5 seconds @ 260° C				
Peak forward current ¹ , I_F	160	160	160	200	mA
Power dissipation P_d (mW)	100	100	100	100	mW
Reversed Voltage (V_R)	5	5	5	5	V

Notes:

1. Measured @ $f=1.0$ kHz, Duty factor = 1/10

HER = High Efficiency Red

ELECTRO-OPTICAL CHARACTERISTICS ($T_A = 25^\circ\text{C}$ Unless otherwise specified)

INDIVIDUAL COMPONENT CHARACTERISTICS

QTLP	HER 670C-2	YELLOW 670C-3	GREEN 670C-4	AlGaAs RED 670C-7	UNITS	TEST CONDITIONS
LUMINOUS INTENSITY						
minimum	6	6	15	25	mcd	$I_F = 20\text{ mA}$
typical	10	10	25	40	mcd	
FORWARD VOLTAGE						
minimum	1.7	1.7	1.7	1.5	V	$I_F = 20\text{ mA}$
typical	2.0	2.0	2.1	1.7	V	
maximum	2.8	2.8	2.8	2.4	V	
PEAK WAVELENGTH	635	585	570	660	nm	$I_F = 20\text{ mA}$
SPECTRAL LINE HALF WIDTH	45	35	30	20	nm	
VIEWING ANGLE	120°	120°	120°	120°		

SOLDERING

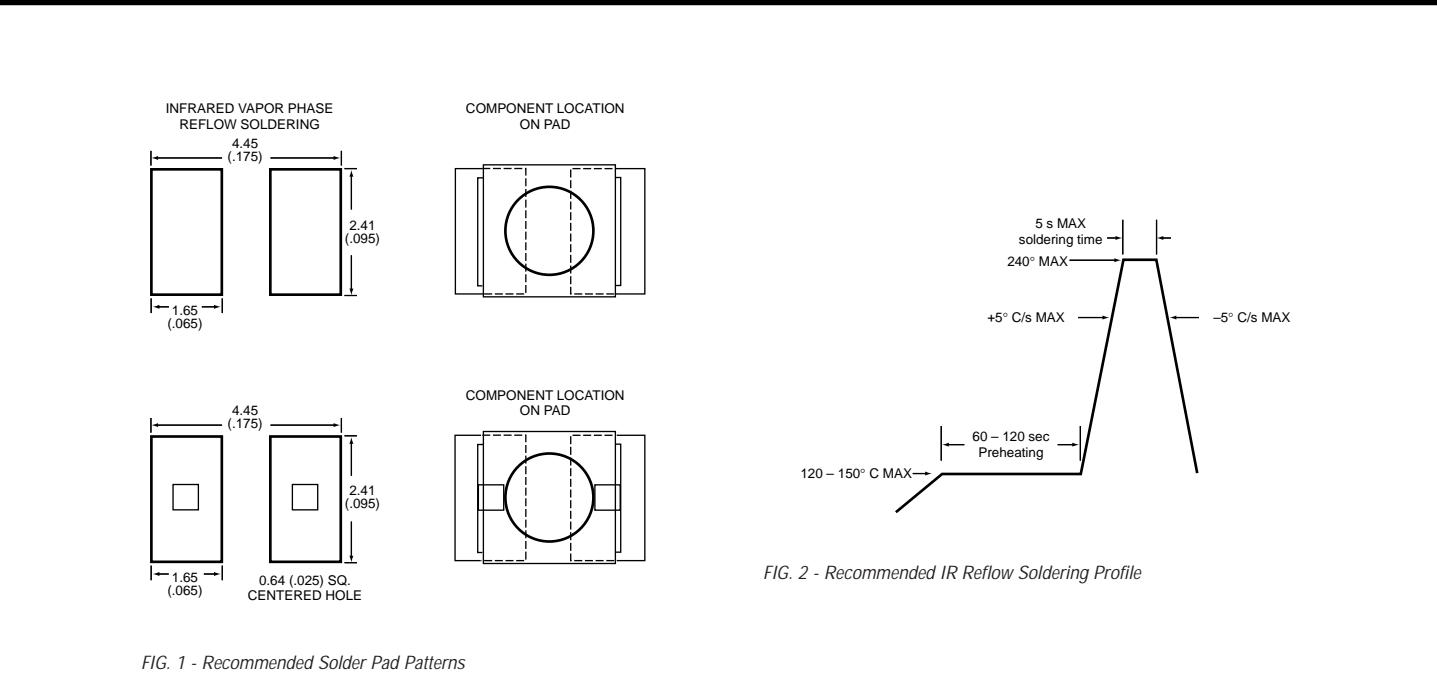

Notes:
All dimensions are in millimeters (inches).
HER = High Efficiency Red

TYPICAL ELECTRO-OPTICAL CHARACTERISTIC CURVES ($T_A = 25^\circ\text{C}$)

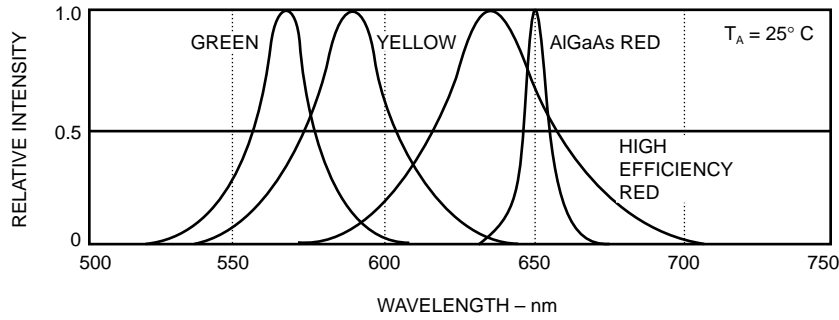

FIG. 3 - Relative Intensity vs. Wavelength

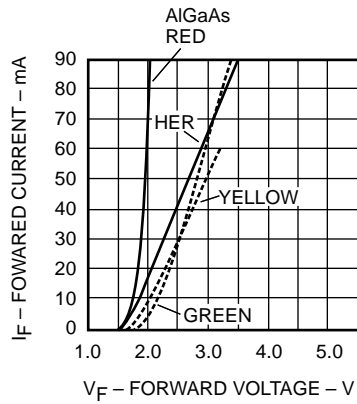

FIG. 4 - Forward Current vs. Forward Voltage

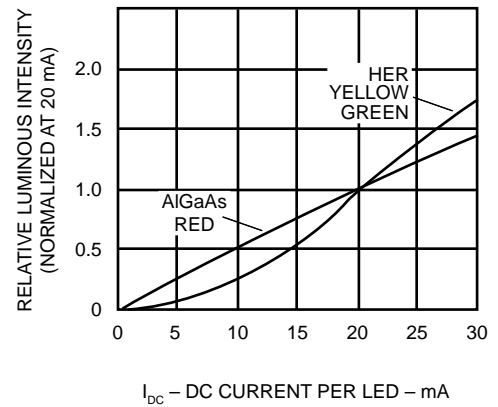

FIG. 5 - Relative Luminous Intensity vs. Forward Current

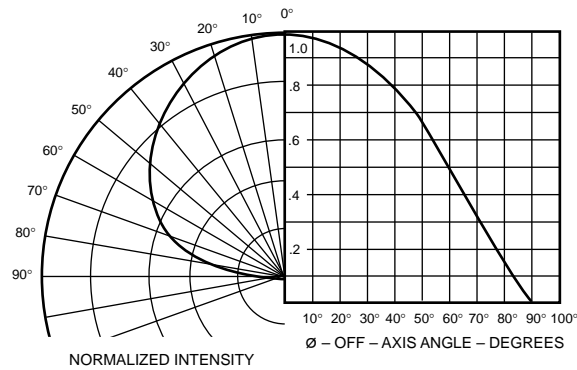
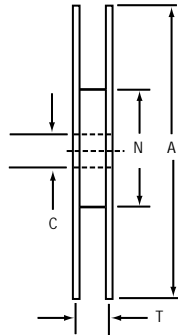
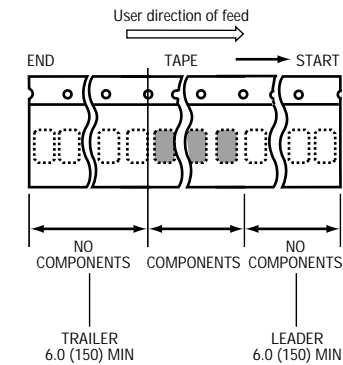

FIG. 6 - Relative Intensity vs. Angular Displacement

8 MM TAPE AND REEL



Dimensions per ANSI/EIA Standard RS-481
All dimensions are in millimeters.

A	7.08 (180) 6.92 (176)
C	0.73 (18.5) 0.69 (17.5) DIA
N	3.19 (81) 3.11 (79)
T	.45 (11.5) .33 (8.5)

Thickness of top cover tape
.004 (10) MAX

NOTES:

1. All dimensions are in inches (mm).
2. Quantity/Reel: 2,000
3. When ordering tape and reel parts, add suffix ".TR" to part number.

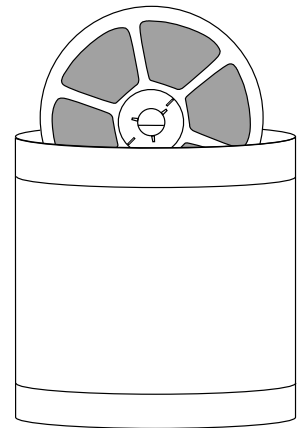

Components are packed in a heat-sealed, moisture-proof aluminum bag.

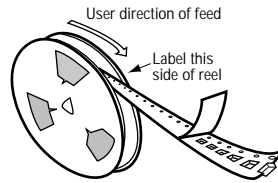
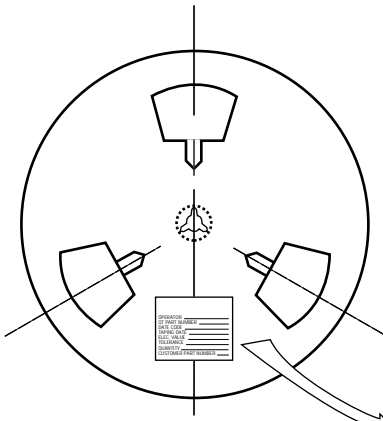

QT
OPERATOR _____
QT PART NUMBER _____
DATE CODE _____
TAPING DATE _____
ELEC. VALUE _____
TOLERANCE _____
QUANTITY _____
CUSTOMER PART NUMBER _____

TAPE DIMENSIONS

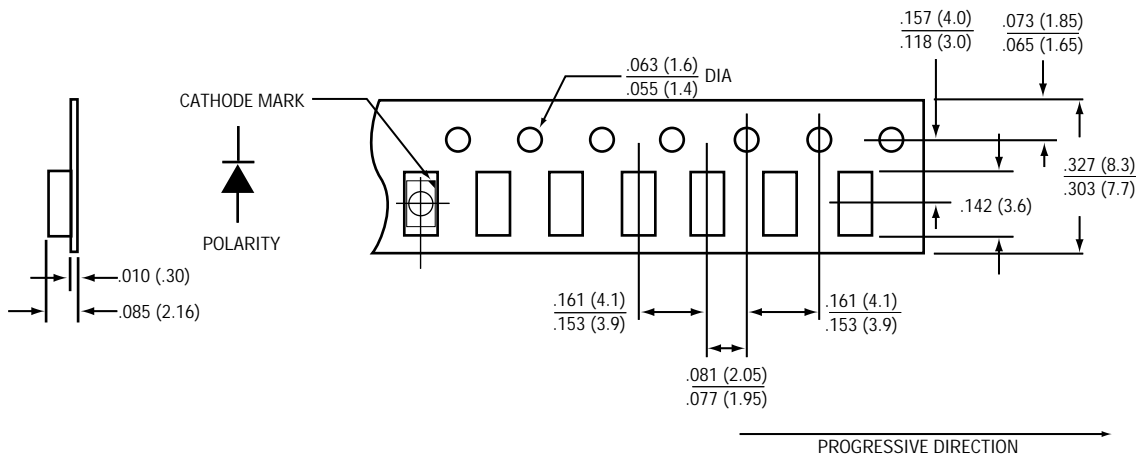

Call QT Optoelectronics for more information or the phone number of your nearest distributor.

United States 800-533-6786 • France 33 1/43.99.25.12 • Germany 49 089/96.30.51 • United Kingdom 44 [0] 1296/39.44.99 • Asia/Pacific 603/735-2417