

QL5732 Enhanced QuickPCI Device Data Sheet



- • • • • 33 MHz/32-bit PCI Master/Target with Embedded Programmable Logic and Dual Port SRAM

Device Highlights

High Performance PCI Controller

- 32-bit / 33 MHz PCI Master/Target
- Zero-wait state PCI Master provides 132 MBps transfer rates
- Zero-wait-state PCI Target Write/One-wait-state PCI Target Read interface
- Supports all PCI commands, including configuration and MWI
- Supports fully-customizable byte enable for master channels
- Target interface supports retry, disconnect with/without data transfer, and target abort
- Fully programmable back-end interface
- Independent PCI bus (33 MHz) and local bus (up to 160 MHz) clocks
- Fully customizable PCI Configuration Space
- Configurable FIFOs with depths up to 256 words
- Reference design with driver code (Win 95/98/Win 2000/NT4.0) available
- PCI v2.3 compliant
- Supports Type 0 Configuration Cycles in Target mode
- 3.3 V PCI signaling
- 2.5 V Supply Voltage
- 484 and 516-pin PBGA
- Supports Extendable PCI functionality
- Unlimited/Continuous Burst Transfers supported

Flexible Programmable Logic

- 1,348 Logic Cells
- 50,688 RAM bits
- Up to 268 I/O pins
- All back-end interface and glue-logic can be implemented on chip
- Six 32-bit busses interface between the PCI Controller and the Programmable Logic
- Twenty-two 2,304 bit Dual Port High Performance SRAM Blocks
- 3,500 flip-flops available

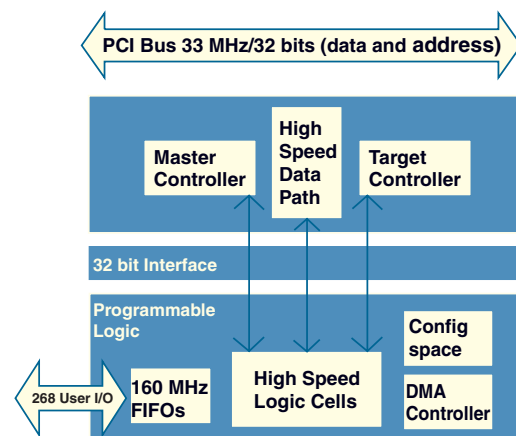

Figure 1: 5732 Block Diagram

Extendable PCI Functionality

- Support for PCI host-bridge function
- Support for Configuration Space from 0 × 40 to 0 × 3FF
- Multi-Function, Expanded Capabilities, and Expansion ROM capable
- PCI v2.3 Power Management Spec compatible
- PCI v2.3 Vital Product Data (VPD) configuration support
- Programmable Interrupt Generator
- I₂O support with local processor
- Mailbox register support

Architecture Overview

The QL5732 device in the QuickLogic® QuickPCI Embedded Standard Product (ESP) family provides a complete and customizable PCI interface solution combined with programmable logic. This device eliminates any need for the designer to worry about PCI bus compliance, yet allows for the maximum 32-bit PCI bus bandwidth (132 MBps).

The programmable logic portion of the device contains 1,348 QuickLogic Logic Cells and 22 QuickLogic Dual-Port RAM Blocks. These configurable RAM blocks can be configured in many width/depth combinations. They can also be combined with logic cells to form FIFOs, or be initialized via Serial EEPROM on power-up and used as ROMs.

The QL5732 device meets PCI 2.3 electrical and timing specifications and has been fully hardware-tested. This device also supports the Win'98 and PC'98 standards. The QL5732 device features 2.5 V operation with multi-volt compatible I/Os. The device can easily operate in 3 V embedded systems and is fully compatible with 3.3 V applications.

PCI Controller

The PCI Controller is a 32-bit/33 MHz PCI 2.3 Compliant Master/Target Controller capable of infinite length Master Write and Read transactions at zero wait states (132 MBps).

The Master will never insert wait states during transfers, so data is supplied or received by FIFOs that can be configured in the programmable region of the device. The Master is capable of initiating any type of PCI commands, including configuration cycles and Memory Write and Invalidate (MWI). This enables the QL5732 device to act as a PCI host. The Master Controller will most often be operated by a DMA Controller in the programmable region of the device. DMA Controller reference design is available and will be included in the QuickWorks® design software.

The Target interface offers full PCI Configuration Space and flexible target addressing. It supports zero-wait-state target Write and one-wait-state target Read operations. It also supports retry, disconnect with/without data transfer, and target abort requested by the back end. Any number of 32-bit BARs may be configured as either memory or I/O space. All required and optional PCI 2.3 Configuration Space registers can be implemented within the programmable region of the device. A reference design of a Target Configuration and Addressing module is available and will be included in the QuickWorks design software.

The interface ports are divided into a set of ports for master transactions and a set for target transactions. The Master DMA controller and Target Configuration Space and Address Decoding are done in the programmable logic region of the device. These functions are not timing critical, so leaving these elements in the programmable region allows the greatest degree of flexibility to the designer. Reference DMA controller, Configuration Space, and Address Decoding blocks are readily available so that the design cycle can be minimized.

Configuration Space and Address Decode

The configuration space is completely customizable in the programmable region of the device. PCI address and command decoding is performed by logic in the programmable section of the device. This allows support for any size of memory or I/O space for back end logic. It also allows the user to implement any subset of the PCI commands supported by the QL5732. QuickLogic provides a reference Address Register/Counter and Command Decode block.

DMA Master Target Controller

The customizable DMA controller included with the QuickWorks design software contains the following features:

- Configurable DMA count size for Reads and Writes (up to 30-bits)
- Configurable DMA burst size for PCI (including unlimited/continuous burst)
- Customizable PCI command to use by core
- Customizable Byte Enable signal
- Programmable Arbitration between DMA Read & Write transactions
- DMA Registers may be mapped to any area of Target Memory Space, including:
 - Read Address (32-bit register)
 - Write Address (32-bit register)
 - Read Length (16-bit register) / Write Length (16-bit register)
 - Control and Status (32-bit register, includes 8 bit Burst Length)
- DMA Registers are available to the local design or the PCI bus
- Programmable Interrupt Control to signal end of transfer or other event

Configurable FIFOs

FIFOs may be created with the RAM/FIFO wizard in the QuickWorks tools. **Figure 2** shows the graphical interface used to create these FIFOs. FIFOs may be designed up to 1,024 words deep. The 22 RAM cells available in the QL5732 allow for up to:

- 11 FIFOs at 128 words deep (36 wide)
- 5 FIFOs at 256 words deep (36 wide)
- 2 FIFOs at 512 words deep (44 wide)
- 1 FIFO at 1,024 words deep (44 wide)



Figure 2: Graphical Interface to create FIFO

PCI Interface Symbol

Figure 2 shows the graphical interface symbol numbers you have to use in your schematic design in order to attach the local interface programmable logic design to the PCI core. If you are designing with a top-level Verilog or VHDL file you must use a structural instantiation of this PCI32_25 μ m block (**Figure 3**) instead of a graphical symbol.

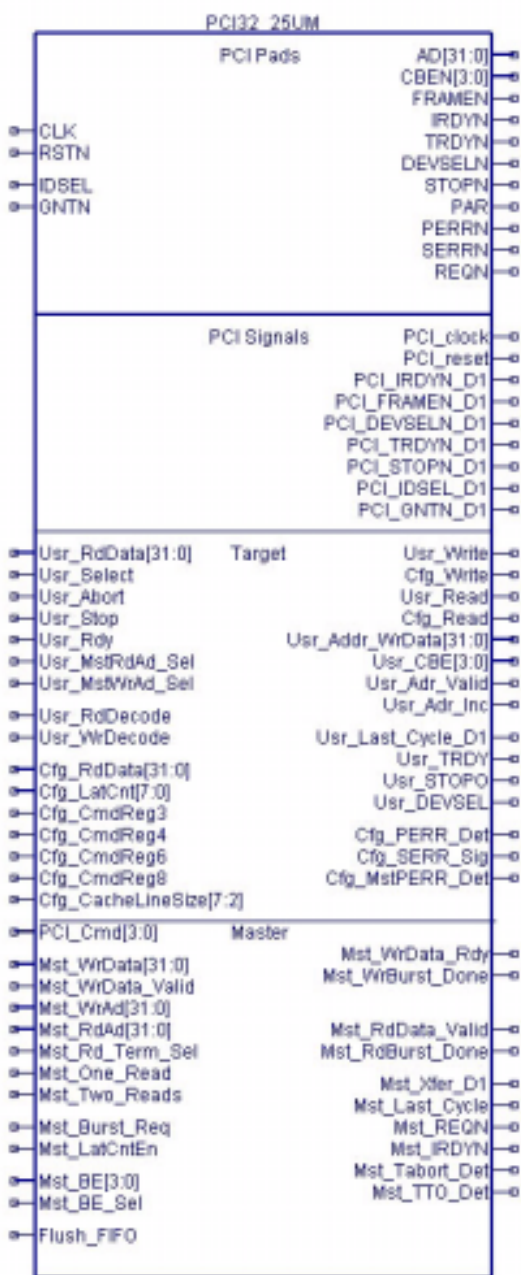

Figure 3: PCI Interface Symbol

PCI Master Interface

The internal signals used to interface with the PCI controller in the QL5732 are listed in **Table 1** along with a description of each signal. The direction of the signal indicates if the signal is an input provided by the local interface (I) or an output provided by the PCI controller (O).

NOTE: Signals that end with the character 'N' should be considered active-low (for example, Mst_IRDYN).

Table 1: PCI Master Interface

Signal	I/O	Description
PCI_cmd[3:0]	I	PCI command to be used for the master transaction This signal must remain unchanged throughout the period when Mst_Burst_Req is active. PCI commands considered as Reads include Interrupt Acknowledge, I/O Read, Memory Read, Configuration Read, Memory Read Multiple, and Memory Read Line. PCI commands considered as Writes include Special Cycle, I/O Write, Memory Write, Configuration Write, Memory Write, and Invalidate. Users should make sure that only valid PCI commands are supplied.
mst_burst_req	I	Request use of the PCI bus When it is active, the core requests the PCI bus and then generates a Master transaction. This signal should be held active until all requested data is transferred on the PCI bus and deactivated in the 2nd clock cycle following the last data transfer on PCI (to avoid being considered as requesting a new transaction).
mst_wrAd[31:0]	I	Address for master DMA writes This address must be treated as valid from the beginning of a DMA Write until the DMA Write operation is complete. It should be incremented by four bytes each time data is transferred on the PCI bus.
mst_rdAd[31:0]	I	Address for master DMA reads This address must be treated as valid from the beginning of a DMA read until the DMA Read operation is complete. It should be incremented by four bytes each time data is transferred on the PCI bus.
Mst_WrData[31:0]	I	Data for master DMA Writes (to PCI bus)
Mst_BE[3:0]	I	Byte enables for master DMA Reads and writes Active-low.
Mst_WrData_Valid	I	Data and byte enable valid on Mst_WrData[31:0] (for master Write only) and Mst_BE[3:0] (for both master Read and Write)
Mst_WrData_Rdy	O	Data receive acknowledge for Mst_WrData[31:0] (for master Write only) and Mst_BE[3:0] (for both) This serves as the PUSH control for the internal FIFO and the POP control for the external FIFO (in FPGA region) which provides data and byte enables to the PCI32 core.
Mst_BE_Sel	I	Byte enable select for master transactions When low, Mst_BE[3:0] should remain constant throughout the entire transfer (when Mst_Burst_Req is active) and it is used for every data phase of the master transaction. When high, Mst_BE[3:0] pushed into internal FIFO (along with data in case of master Write) is used. Should be held constant throughout the transaction.
Mst_WrBurst_Done	O	Master Write transaction is completed Active for only one clock cycle.
Mst_Rd_Term_Sel	I	Master Read termination mode select when Mst_BE_Sel is high When both Mst_BE_Sel and Mst_Rd_Term_Sel are high, Master Read termination happens when the internal FIFO is empty, and Mst_Two_Reads and Mst_One_Read are ignored. When either signal is low, Mst_Two_Reads and Mst_One_Read are used to signal the end of Master Read. Should be held constant throughout the transaction.
Mst_One_Read	I	Signals to the PCI32 core that only one data transfer remains to be read in the burst Read.

Table 1: PCI Master Interface

Signal	I/O	Description
Mst_Two_Reads	I	Two data transfers remain to be read in the burst Read It is not used for single-data-phase Master Read transactions.
Mst_RdData_Valid	O	Master Read data valid on User Addr WrData[31:0] This serves as the PUSH control for the external FIFO (in FPGA region) that receives data from the PCI32 core.
Mst_RdBurst_Done	O	Master Read transaction is completed Active for only one clock cycle.
Flush_FIFO	I	Internal FIFO flush FIFO flushed immediately after it is active (synchronized with PCI clock).
Mst_LatCntEn	I	Enable Latency Counter Set to 0 to ignore the Latency Timer in the PCI configuration space (offset 0Ch). For full PCI compliance, this port should be always set to 1.
Mst_Xfer_D1	O	Data was transferred on the previous PCI clock Useful for updating DMA transfer counts on DMA Read operations
Mst_Last_Cycle	O	Active during the last data transfer of a master transaction
Mst_REQN	O	Copy of the PCI REQN signal generated by QL5732 as PCI master Not usually used in the back-end design.
Mst_IRDYN	O	Copy of the PCI IRDYN signal generated by QL5732 as PCI master Valid only when QL5732 is the PCI master. Kept low otherwise. Not usually used in the back-end design.
Mst_Tabort_Det	O	Target abort detected during master transaction This is normally an error condition handled in the DMA controller.
Mst_TTO_Det	O	Target timeout detected (no response from target) This is normally an error condition handled in the DMA controller.

PCI Target Interface

Table 2: PCI Target Interface

Signal	I/O	Description
Usr_Addr_WrData[31:0]	O	Target address, and target Write data During all target accesses, the address is presented on Usr_Addr_WrData[31:0]; at the same time, Usr_Adr_Valid is active. During target Write transactions, this port also presents valid Write data to the PCI configuration space or user logic when Usr_Adr_Inc is active.
Usr_CBE[3:0]	O	PCI command and byte enables During target accesses, the PCI command is presented on Usr_CBE[3:0]; at the same time, Usr_Adr_Valid is active. This port also presents active-low byte enables to the PCI configuration space or user logic.
Usr_Adr_Valid	O	Indicates the beginning of a PCI transaction, and that a target address is valid on Usr_Addr_WrData[31:0] and the PCI command is valid on Usr_CBE[3:0]. When this signal is active, the target address must be latched and decoded to determine if this address belongs to the device's memory or I/O space. Also, the PCI command must be decoded to determine the type of PCI transaction. On subsequent clocks of a target access, this signal is low, indicating that address is NOT present on Usr_Addr_WrData[31:0].
Usr_Adr_Inc	O	Indicates that the target address should be incremented, because the previous data transfer has completed. During burst target accesses, the target address is only presented to the back-end logic at the beginning of the transaction (when Usr_Adr_Valid is active), and must therefore be latched and incremented by four for subsequent data transfers. Note that during target Write transactions, Usr_Adr_Inc indicates valid data on Usr_Addr_WrData[31:0] that must be accepted by the backend logic (regardless of the state of Usr_Rdy). During Read transactions, Usr_Adr_Inc signals to the backend that the PCI core has presented the read data on the PCI bus (TRDYN asserted).
Usr_RdDecode	I	This signal should be the combinatorial decode of the "user read" command from Usr_CBE[3:0]. This command may be mapped from any of the PCI Read commands, such as Memory Read, Memory Read Line, Memory Read Multiple, I/O Read, etc. It is internally gated with Usr_Adr_Valid.
Usr_WrDecode	I	This signal should be the combinatorial decode of the "user write" command from Usr_CBE[3:0]. This command may be mapped from any of the PCI Write commands, such as Memory Write or I/O Write. It is internally gated with Usr_Adr_Valid.
Usr_Select	I	This signal should be driven active when the address on Usr_Addr_WrData[31:0] has been decoded and determined to be within the address space of the device. Usr_Addr_WrData[31:0] must be compared to each of the valid Base Address Registers in the PCI configuration space. Also, this signal must be gated by the Memory Access Enable or I/O Access Enable registers in the PCI configuration space (Command Register bits 1 or 0 at offset 04h). Internally gated with Usr_Adr_Valid.
Usr_Write	O	This signal is active throughout a "user write" transaction, which has been decoded by Usr_WrDecode at the beginning of the transaction. The Write strobe for individual DWORDs of data (on Usr_Addr_WrData[31:0]) during a user Write transaction should be generated by logically ANDing this signal with Usr_Adr_Inc.
Cfg_Write	O	This signal is active throughout a "configuration write" transaction. The Write strobe for individual DWORDs of data (on Usr_Addr_WrData[31:0]) during a configuration Write transaction should be generated by logically ANDing this signal with Usr_Adr_Inc.
Usr_Read	O	This signal is active throughout a "user read" transaction, which has been decoded by Usr_RdDecode at the beginning of the transaction.
Cfg_Read	O	This signal is active throughout a "configuration read" transaction.

Table 2: PCI Target Interface

Signal	I/O	Description
Cfg_RdData[31:0]	I	Data from the PCI configuration registers, required to be presented during PCI configuration reads.
Usr_RdData[31:0]	I	Data from the back-end user logic required to be presented during PCI user reads.
Cfg_CmdReg3	I	Bit 3 from the Command Register in the PCI configuration space (offset 04h). Enable Special Cycle monitoring. If high, the core reports data parity error in Special Cycles through SERRN if Cfg_CmdReg8 is active.
Cfg_CmdReg4	I	Bit 4 from the Command Register in the PCI configuration space (offset 04h). Memory Write and Invalidate (MWI) Enable. If high, the core generates MWI transactions as requested by the backend. Otherwise it uses Memory Write instead even if MWI is requested.
Cfg_CmdReg6	I	Bit 6 from the Command Register in the PCI configuration space (offset 04h). Parity Error Response. If high, the core uses PERRN to report data parity errors. Otherwise it never drives it.
Cfg_CmdReg8	I	Bit 8 from the Command Register in the PCI configuration space (offset 04h). SERRN Enable. If high, the cores uses SERRN to report address parity errors if Cfg_CmdReg6 is high.
Cfg_LatCnt[7:0]	I	8-bit value of the Latency Timer in the PCI configuration space (offset 0Ch).
Usr_MstRdAd_Sel	I	Used when a target Read operation should return the value set on the Mst_RdAd[31:0] pins. This select pin saves on logic which would otherwise need to be used to multiplex Mst_RdAd[31:0] into the Usr_RdData[31:0] bus. When this signal is asserted, the data on Usr_RdData[31:0] is ignored.
Usr_MstWrAd_Sel	I	Used when a target read operation should return the value set on the Mst_WrAd[31:0] pins. This select pin saves on logic which would otherwise need to be used to multiplex Mst_WrAd[31:0] into the Usr_RdData[31:0] bus. When this signal is asserted, the data on Usr_RdData[31:0] is ignored.
Cfg_PERR_Det	O	Parity error detected on the PCI bus. When this signal is active, bit 15 of the Status Register must be set in the PCI configuration space (offset 04h).
Cfg_SERR_Sig	O	System error asserted on the PCI bus. When this signal is active, the Signalled System Error bit, bit 14 of the Status Register, must be set in the PCI configuration space (offset 04h).
Cfg_MstPERR_Det	O	Data parity error detected on the PCI bus by the master. When this signal is active, bit 8 of the Status Register must be set in the PCI configuration space (offset 04h).
Usr_TRDY	O	Inverted copy of the TRDYN signal as driven by the PCI target interface. Valid only within a target access.
Usr_STOPO	O	Inverted copy of the STOPN signal as driven by the PCI target interface. Valid only within a target access.
Usr_DEVSEL	O	Inverted copy of the DEVSELN signal as driven by the PCI target interface. Valid only within a target access.
Usr_Last_Cycle_D1	O	Active one clock cycle after the last data phase (may not with data transfer) occurs on PCI and inactive one clock cycle afterwards.
Usr_Rdy	I	Used to delay (add wait states to) a target PCI transaction when the backend needs additional time to provide data (read) or accept data (write). Subject to PCI latency restrictions.
Usr_Stop	I	Used to prematurely stop a PCI target access on the next PCI clock.
Usr_Abort	I	Used to signal Target Abort on PCI when the backend has fatal errors and is unable to complete a transaction. Rarely used.

PCI Internal Signals

Table 3: PCI Internal Signals

Signal		Description
PCI_clock	O	PCI clock.
PCI_reset	O	PCI reset signal.
PCI_IRDYN_D1	O	Copy of the IRDYN signal from the PCI bus, delayed by one clock.
PCI_FRAMEN_D1	O	Copy of the FRAMEN signal from the PCI bus, delayed by one clock.
PCI_DEVSELN_D1	O	Copy of the DEVSELN signal from the PCI bus, delayed by one clock.
PCI_TRDYN_D1	O	Copy of the TRDYN signal from the PCI bus, delayed by one clock.
PCI_STOPN_D1	O	Copy of the STOPN signal from the PCI bus, delayed by one clock.
PCI_IDSEL_D1	O	Copy of the IDSEL signal from the PCI bus, delayed by one clock.

RAM Module Features

The QL5732 device has twenty-two 2,304-bit RAM modules, for a total of 50,668 RAM bits. Using two “mode” pins, designers can configure each module into 128×18 , 256×9 , 512×4 , or 1024×2 blocks (see **Figure 1**). The blocks are also easily cascadable to increase their effective width or depth.

The RAM modules are “dual-ported” with completely independent Read and Write ports and separate Read and Write clocks. The Read ports support asynchronous and synchronous operation, while the Write ports support synchronous operation. Each port has 18 data lines and ten address lines, allowing word lengths of up to 18 bits and address spaces of up to 1,024 words. Depending on the mode selected, however, some higher order data or address lines may not be used.

The Write Enable (WE) line acts as a clock enable for synchronous Write operation. The Read Enable (RE) acts as a clock enable for synchronous Read operation (ASYNCRD input low), or as a flow-through enable for asynchronous Read operation (ASYNCRD input high).

Designers can cascade multiple RAM modules to increase the depth or width allowed in single modules by connecting corresponding address lines together and dividing the words between modules. This approach allows up to 1,024-deep configurations as large as 44 bits wide in the QL5732 device.

A similar technique can be used to create depths greater than 1,024 words. In this case, address signals higher than the eighth bit are encoded onto the write enable (WE) input for Write operations. The Read data outputs are multiplexed together using encoded higher Read address bits for the multiplexer SELECT signals.

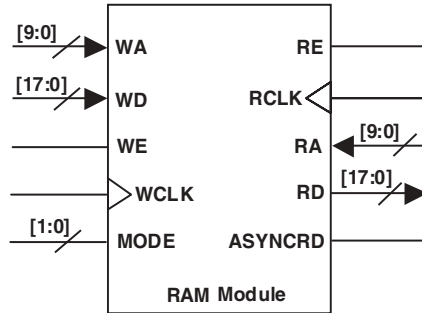

Figure 4: RAM Module

QL5732 Embedded Computational Unit (ECU)

Traditional Programmable Logic architectures do not implement arithmetic functions efficiently—these functions require high logic cell usage while achieving only moderate performance results.

The QL5732 architecture allows for functionality above and beyond that achievable using programmable logic devices. By embedding a dynamically reconfigurable computational unit, the QL5732 device can address various arithmetic functions efficiently—this approach offers greater performance than traditional programmable logic implementations. The embedded block is implemented at the transistor level as shown in **Figure 5**.

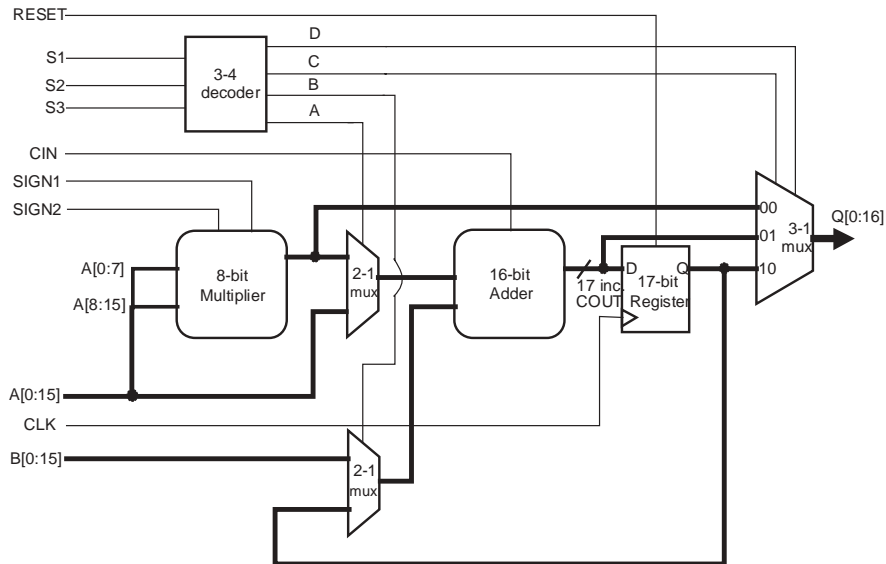

Figure 5: ECU Block Diagram

The 12 QL5632 ECU blocks are placed next to the SRAM circuitry for efficient memory/instruction fetch and addressing for DSP algorithmic implementations.

Twelve 8-bit MAC functions can be implemented per cycle for a total of ~1.2 billion MACs/s when clocked at 98 MHz. Additional multiply-accumulate functions can be implemented in the programmable logic.

The modes for the ECU block are dynamically re-programmable through the programmable logic.

Table 4: ECU Mode Select Criteria

Instruction			Operation	ECU Performance ^a , -B WCC		
S1	S2	S3		t _{PD}	t _{SU}	t _{CO}
0	0	0	Multiply	7.0 ns max		
0	0	1	Multiply-Add	9.4 ns max		
0	1	0	Accumulate ^b		4.1 ns min	1.2 ns max
0	1	1	Add	3.3 max		
1	0	0	Multiply (registered) ^c		10.2 ns min	1.2 ns max
1	0	1	Multiply- Add (registered)		10.2 ns min	1.2 ns max
1	1	0	Multiply - Accumulate		10.2 ns min	1.2 ns max
1	1	1	Add (registered)		4.1 ns min	1.2 ns max

- a. t_{PD}, t_{SU} and t_{CO} do not include routing paths in/out of the ECU block.
- b. Internal feedback path in ECU restricts max clk frequency to 224 MHz.
- c. B [15:0] set to zero.

NOTE: Timing numbers in **Table 1** represent -B Worst Case Commercial conditions.

Phase Locked Loop (PLL) Information

Instead of requiring extra components, designers simply need to instantiate one of the pre-configured models (described in this section). The QuickLogic built-in PLLs support a wider range of frequencies than many other PLLs. These PLLs also have the ability to be cascaded to support different ranges of frequency multiplications or divisions, driving the device at a faster or slower rate than the incoming clock frequency. Most importantly, they achieve a very short clock-to-out time—generally less than 3 ns. This low clock-to-out time is achieved by the PLL subtracting the clock tree delay through the feedback path, effectively making the clock tree delay zero.

Figure 6 illustrates a typical QuickLogic ESP PLL.

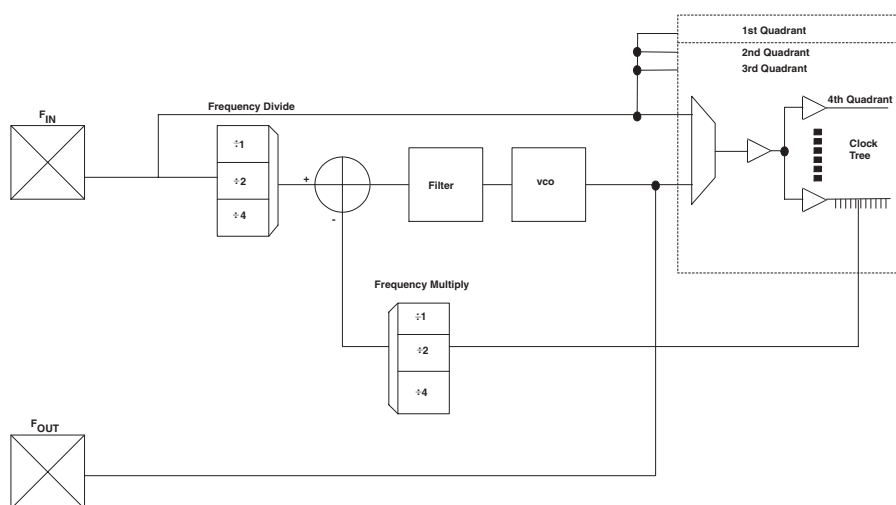

Figure 6: PLL Block Diagram

F_{in} represents a very stable high-frequency input clock and produces an accurate signal reference. This signal can either bypass the PLL entirely, thus entering the clock tree directly, or it can pass through the PLL itself.

Within the PLL, a voltage-controlled oscillator (VCO) is added to the circuit. The external F_{in} signal and the local VCO form a control loop. The VCO is multiplied or divided down to the reference frequency, so that a phase detector (the crossed circle in **Figure 6**) can compare the two signals. If the phases of the external and local signals are not within the tolerance required, the phase detector sends a signal through the charge pump and loop filter (**Figure 6**). The charge pump generates an error voltage to bring the VCO back into alignment, and the loop filter removes any high frequency noise before the error voltage enters the VCO. This new VCO signal enters the clock tree to drive the chip's circuitry.

F_{out} represents the clock signal emerging from the output pad (the output signal PLLPAD_OUT is explained in **Table 6**). This clock signal is meaningful only when the PLL is configured for external use; otherwise, it remains in high Z state, as shown in the post-simulation waveform.

Most QuickLogic products contain four PLLs. The PLL presented in **Figure 6** controls the clock tree in the fourth Quadrant of its ESP. QuickLogic PLLs compensate for the additional delay created by the clock tree itself, as previously noted, by subtracting the clock tree delay through the feedback path.

For more specific information on the Phase Locked Loops, please refer to Application Note 58 at <http://www.quicklogic.com/images/appnote58.pdf>

PLL Modes of Operation

QuickLogic PLLs have eight modes of operation, based on the input frequency and desired output frequency—**Table 5** indicates the features of each mode.

NOTE: "HF" stands for "high frequency" and "LF" stands for "low frequency."

Table 5: PLL Mode Frequencies

PLL Model	Output Frequency	Input Frequency Range	Output Frequency Range
PLL_HF	Same as input	66 MHz–150 MHz	66 MHz–150 MHz
PLL_LF	Same as input	25 MHz–133 MHz	25 MHz–133 MHz
PLL_MULT2HF	2x	50 MHz–125 MHz	100 MHz–250 MHz
PLL_MULT2LF	2x	16 MHz–50 MHz	32 MHz–100 MHz
PLL_DIV2HF	1/2x	100 MHz–250 MHz	50 MHz–125 MHz
PLL_DIV2LF	1/2x	50 MHz–100 MHz	25 MHz–50 MHz
PLL_MULT4	4x	16 MHz–40 MHz	64 MHz–160 MHz
PLL_DIV4	1/4x	100 MHz–300 MHz	25 MHz–75 MHz

NOTE: The input frequency can range from 16 MHz to 300 MHz, while output frequency ranges from 25 MHz to 250 MHz. When you add PLLs to your top-level design, be sure that the PLL mode matches your desired input and output frequencies.

PLL Signals

Table 6 summarizes the key signals in QuickLogic's PLLs.

Table 6: PLL Signals

Signal Name	Description
PLLCLK_IN	Input clock signal
PLL_RESET	Active High Reset If PLL_RESET is asserted, then CLKNET_OUT and PLLPAD_OUT are reset to 0. This signal must be asserted and then released in order for the LOCK_DETECT to work.
ONn_OFFCHIP	PLL output This signal selects whether the PLL will drive the internal clock network or be used off-chip. This is a static signal, not a dynamic signal. Tied to GND = outgoing signal drives internal gates. Tied to VCC = outgoing signal used off-chip.
CLKNET_OUT	Out to internal gates This signal bypasses the PLL logic before driving the internal gates. Note that this signal cannot be used in the same quadrant where the PLL signal is used (PLLCLK_OUT).
PLLCLK_OUT	Out from PLL to internal gates This signal can drive the internal gates after going through the PLL. For this to work, ONn_OFFCHIP must be tied to GND.
PLLPAD_OUT	Out to off-chip This outgoing signal is used off-chip. For this to work, ONn_OFFCHIP signal must be tied to VCC.
LOCK_DETECT	Active High Lock detection signal NOTE: For simulation purposes, this signal gets asserted after 10 clock cycles. However, it can take a maximum of 200 clock cycles to sync with the input clock upon release of the RESET signal.

NOTE: Because PLLCLK_IN and PLL_RESET signals have INPAD, and PLLPAD_OUT has OUTPAD, you do not have to add additional pads to your design.

Joint Test Access Group (JTAG) Support

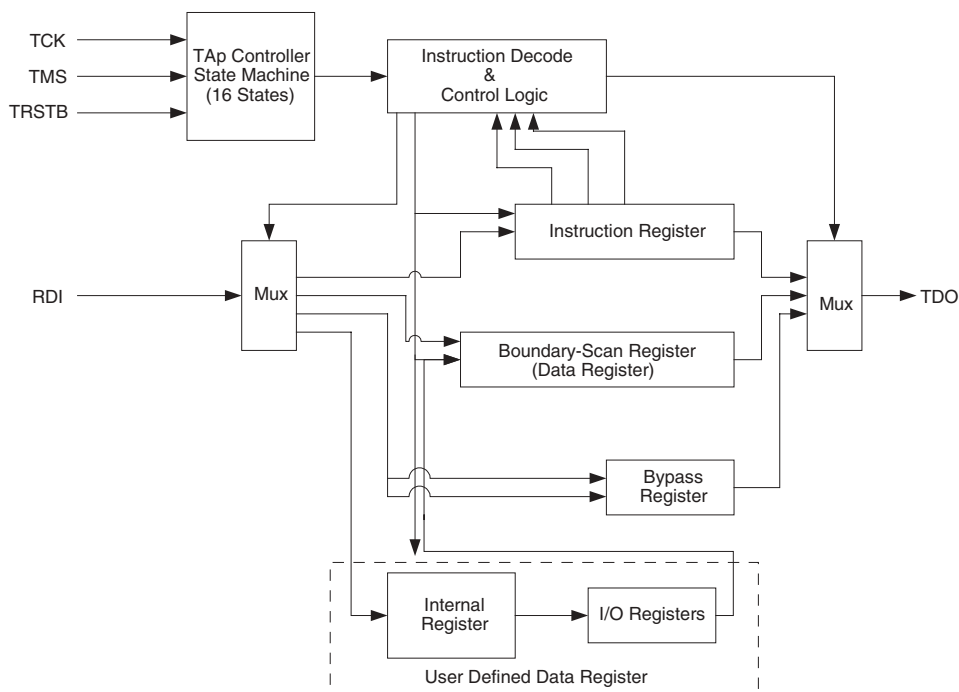

Figure 7: JTAG Block Diagram

JTAG pins support the IEEE Standard 1149.1a to provide boundary scan capability for the QL5732 device. Six pins are dedicated to JTAG and programming functions on each QL5732 device; these pins are unavailable for general design input and output signals. TDI, TDO, TCK, TMS, and TRSTB are JTAG pins. The sixth pin, STM, is used only for programming.

Microprocessors and Application Specific Integrated Circuits (ASICs) pose many design challenges, one problem being the accessibility of test points. JTAG was formed in response to this challenge, resulting in IEEE standard 1149.1, the Standard Test Access Port and Boundary Scan Architecture.

The JTAG boundary scan test methodology allows complete observation and control of the boundary pins of a JTAG-compatible device through JTAG software. A Test Access Port (TAP) controller works in concert with the Instruction Register (IR); these allow users to run three required tests, along with several user-defined tests.

JTAG tests allow users to reduce system debug time, reuse test platforms and tools, and reuse subsystem tests for fuller verification of higher level system elements.

The JTAG 1149.1 standard requires the following three tests:

- **Extest Instruction.** The Extest instruction performs a PCB interconnect test. This test places a device into an external boundary test mode, selecting the boundary scan register to be connected between the TAP's Test Data In (TDI) and Test Data Out (TDO) pins. Boundary scan cells are preloaded with test patterns (via the Sample/Preload Instruction), and input boundary cells capture the input data for analysis.
- **Sample/Preload Instruction.** This instruction allows a device to remain in its functional mode, while selecting the boundary scan register to be connected between the TDI and TDO pins. For this test, the boundary scan register can be accessed via a data scan operation, allowing users to sample the functional data entering and leaving the device.
- **Bypass Instruction.** The Bypass instruction allows data to skip a device's boundary scan entirely, so the data passes through the bypass register. The Bypass instruction allows users to test a device without passing through other devices. The bypass register connects the TDI and TDO pins, allowing serial data to be transferred through a device without affecting the operation of the device.

Development Tool Support

Software support for the QL5732 device is available through the QuickWorks development package. This turnkey PC-based QuickWorks package, shown in **Figure 8**, provides a complete ESP software solution with design entry, logic synthesis, place and route, and simulation. QuickWorks includes VHDL, Verilog, schematic, and mixed-mode entry with fast and efficient logic synthesis provided by the integrated Synplicity Synplify Lite™ tool, specially tuned to take advantage of the QL5732 architecture. QuickWorks also provides functional and timing simulation for guaranteed timing and source-level debugging.

The UNIX-based QuickTools package is a subset of QuickWorks and provides a solution for designers who use schematic-only design flow third-party tools for design entry, synthesis, or simulation. QuickTools Reads EDIF netlists and provides support for all QuickLogic devices. QuickTools also supports a wide range of third-party modeling and simulation tools.

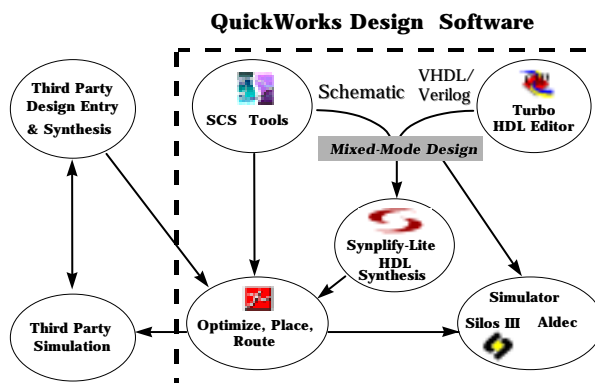

Figure 8: QuickWorks Tool Suite

Electrical Specifications

Table 7: Absolute Maximum Ratings

V _{CC} Voltage	-0.5 V to 3.6 V	DC Input Current	±20 mA
V _{CCIO} Voltage	-0.5 V to 4.6 V	ESD Pad Protection	±2000 V
V _{REF} Voltage	2.7 V	Leaded Package Storage Temperature	-65°C to +150°C
Input Voltage	-0.5 V to V _{CCIO} + 0.5 V	Laminate Package (BGA) Storage Temperature	-55°C to +125°C

Table 8: Operating Range

Symbol	Parameter	Military		Industrial		Commercial		
		Min	Max	Min	Max	Min	Max	
V _{CC}	Supply Voltage	2.3 V	2.7 V	2.3 V	2.7 V	2.3 V	2.7 V	
V _{CCIO}	I/O Input Tolerance Voltage	2.3 V	3.6 V	2.3 V	3.6 V	2.3 V	3.6 V	
TA	Ambient Temperature	-55°C		-40°C	85 °C	0°C	70°C	
TC	Case Temperature	-	125°C	-	-	-	-	
K	Delay Factor	-B Speed Grade	0.42	1.35	0.43	1.26	0.46	1.23

DC Characteristics

Table 9: DC Characteristics

Symbol	Parameter	Conditions	Temperature	
			Min	Max
I_I	I or I/O Input Leakage Current	$V_I = V_{CCIO}$ or GND	-10 μ A	10 μ A
I_{OZ}	3-State Output Leakage Current	$V_I = V_{CCIO}$ or GND	-10 μ A	10 μ A
C_I	Input Capacitance ^a	-	-	8 pF
I_{OS}	Output Short Circuit Current ^b	$V_o =$ GND $V_o = V_{CC}$	-15 mA 40 mA	-180 mA 210 mA
I_{CC}	D.C. Supply Current	$V_I, V_o = V_{CCIO}$ or GND	0.50 mA(typ)	2 mA
I_{CCIO}	D.C. Supply Current on V_{CCIO}	-	0 mA	2 mA
$I_{CCIO(DIF)}$	D.C. Supply Current on V_{CCIO} for Differential I/O	-	-	-
I_{REF}	D.C. Supply Current on V_{REF}	-	-10 μ A	10 μ A
I_{PD}	Pad Pull-down (programmable)	$V_{CCIO} = 3.6$ V	-	150 μ A

a. Capacitance is sample tested only. Clock pins are 12 pF maximum.

b. Only one output at a time. Duration should not exceed 30 seconds.

Table 10: DC Input and Output Levels

	INREF		V_{IL}		V_{IH}		V_{OL}	V_{OH}	I_{OL}	I_{OH}
	V_{MIN}	V_{MAX}	V_{MIN}	V_{MAX}	V_{MIN}	V_{MAX}	V_{MAX}	V_{MIN}	mA	mA
LVTTL	n/a	n/a	-0.3	0.8	2.0	$V_{CCIO} + 0.3$	0.4	2.4	2.0	-2.0
LVC MOS 2	n/a	n/a	-0.3	0.7	1.7	$V_{CCIO} + 0.3$	0.7	1.7	2.0	-2.0
GTL+	0.88	1.12	-0.3	INREF - 0.2	INREF + 0.2	$V_{CCIO} + 0.3$	0.6	n/a	40	n/a
PCI	n/a	n/a	-0.3	$0.3 \times V_{CCIO}$	$0.5 \times V_{CCIO}$	$V_{CCIO} + 0.5$	$0.1 \times V_{CCIO}$	$0.9 \times V_{CCIO}$	1.5	-0.5
SSTL2	1.15	1.35	-0.3	INREF - 0.18	INREF + 0.18	$V_{CCIO} + 0.3$	0.74	1.76	7.6	-7.6
SSTL3	1.3	1.7	-0.3	INREF - 0.2	INREF + 0.2	$V_{CCIO} + 0.3$	1.10	1.90	8	-8

NOTE: The data provided in Table 10 are JEDEC and PCI Specifications—QuickLogic devices either meet or exceed these requirements.

NOTE: All CLK and IOCTRL pins are clamped to the V_{CC} rail, not the V_{CCIO} . Therefore, these pins can only be driven up to $V_{CC} + 0.3$ V.

AC Characteristics

The AC characteristics are calculated at 2.5 V, TA = 25°C (K = 0.74). To calculate delays, multiply the appropriate K factor in **Table 8** by the numbers presented in **Table 11** through **Table 17**.

Table 11: Logic Cells

Symbol Logic Cells	Parameter	Value	
		Min	Max
t_{PD}	Combinatorial Delay of the longest path: time taken by the combinatorial circuit to output	-	0.257 ns
t_{SU}	Setup time: time the synchronous input of the flip flop must be stable before the active clock edge	0.22 ns	-
t_{HL}	Hold time: time the synchronous input of the flip flop must be stable after the active clock edge	0	-
t_{CO}	Clock to out delay: the amount of time taken by the flip flop to output after the active clock edge.	-	0.255 ns
t_{CWHI}	Clock High Time: required minimum time the clock stays high	0.46 ns	-
t_{CWLO}	Clock Low Time: required minimum time that the clock stays low	0.46 ns	-
t_{SET}	Set Delay: time between when the flip flop is "set" (high) and when the output is consequently "set" (high)	-	0.18 ns
t_{RESET}	Reset Delay: time between when the flip flop is "reset" (low) and when the output is consequently "reset" (low)	-	0.09 ns
t_{SW}	Set Width: time that the SET signal remains high/low	0.3 ns	-
t_{RW}	Reset Width: time that the RESET signal remains high/low	0.3 ns	-

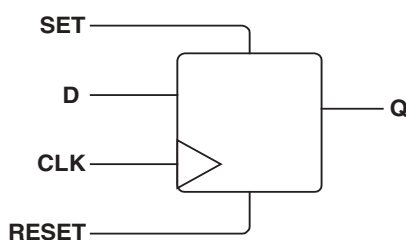

Figure 9: Logic Cell

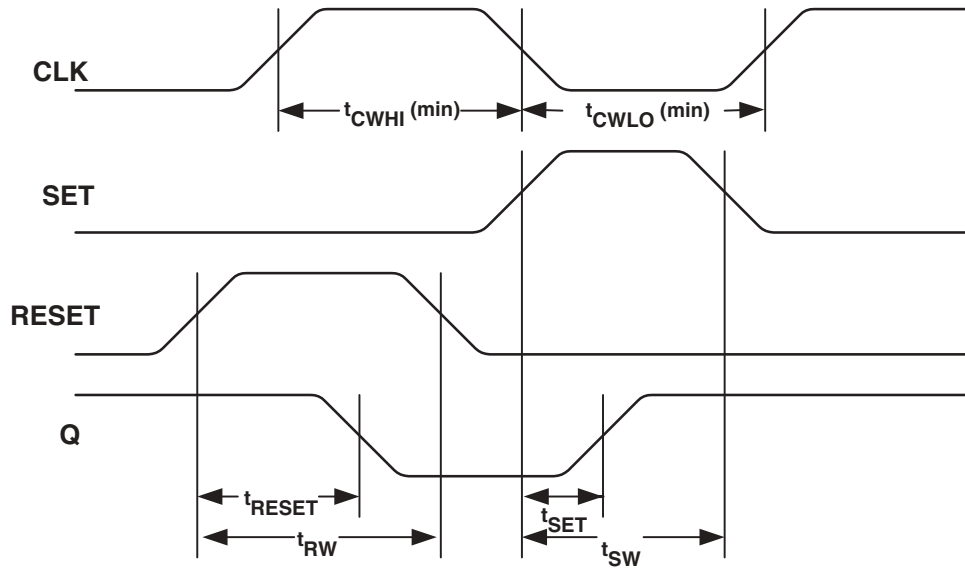

Figure 10: Logic Cell Flip Flop Timing—First Waveform

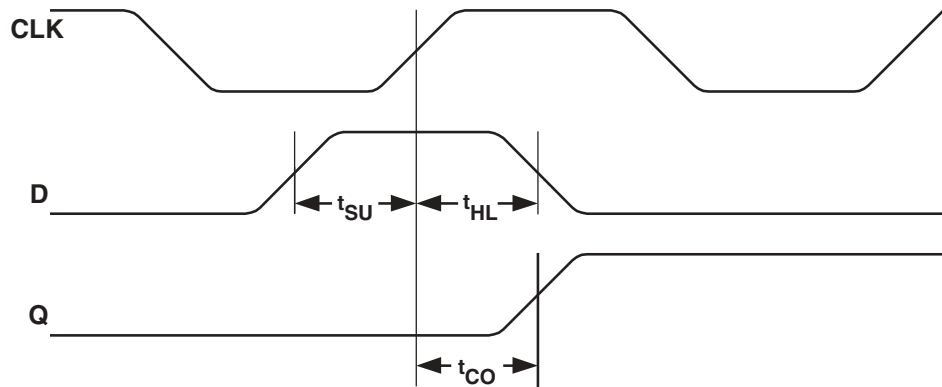

Figure 11: Logic Cell Flip Flop Timing—Second Waveform

Table 12: RAM Cell Synchronous Write Timing

Symbol	Parameter: RAM Cell Synchronous Write Timing	Value Min
t_{SWA}	WA setup time to WCLK: the amount of time the Write ADDRESS must be stable before the active edge of the Write CLOCK	0.675 ns
t_{HWA}	WA hold time to WCLK: the amount of time the Write ADDRESS must be stable after the active edge of the Write CLOCK	0 ns
t_{SWD}	WD setup time to WCLK: the amount of time the Write DATA must be stable before the active edge of the Write CLOCK	0.654 ns
t_{HWD}	WD hold time to WCLK: the amount of time the Write DATA must be stable after the active edge of the Write CLOCK	0 ns
t_{SWE}	WE setup time to WCLK: the amount of time the Write ENABLE must be stable before the active edge of the Write CLOCK	0.623 ns
t_{HWE}	WE hold time to WCLK: the amount of time the Write ENABLE must be stable after the active edge of the Write CLOCK	0 ns
t_{WCRD}	WCLK to RD (WA=RA): the amount of time between the active Write CLOCK edge and the moment when the data is available at RD	-

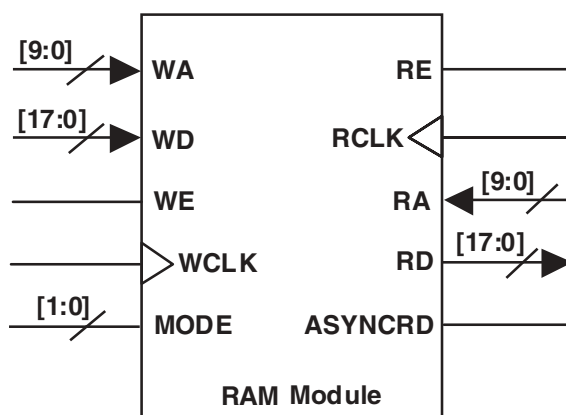

Figure 12: RAM Module

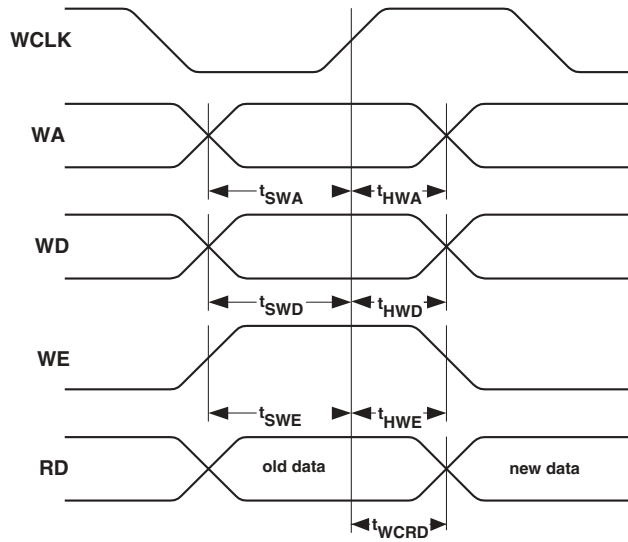

Figure 13: RAM Cell Synchronous Write Timing

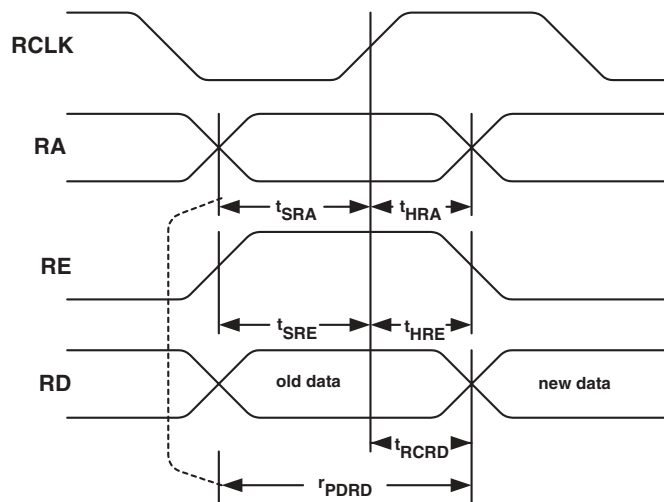

Figure 14: RAM Cell Synchronous & Asynchronous Read Timing

Table 13: RAM Cell Synchronous & Asynchronous Read Timing

Symbol	Parameter: RAM Cell Synchronous Read Timing	Value	
		Min	Max
t_{SRA}	RA setup time to RCLK: time the Read ADDRESS must be stable before the active edge of the Read CLOCK	0.686 ns	-
t_{HRA}	RA hold time to RCLK: time the Read ADDRESS must be stable after the active edge of the Read CLOCK	0 ns	-
t_{SRE}	RE setup time to WCLK: time the Read ENABLE must be stable before the active edge of the Read CLOCK	0.243 ns	-
t_{HRE}	RE hold time to WCLK: time the Read ENABLE must be stable after the active edge of the Read CLOCK	0	-
t_{RCRD}	RCLK to RD: time between the active Read CLOCK edge and the time when the data is available at RD	-	4.38 ns
RAM Cell Asynchronous Read Timing			
t_{PDRD}	RA to RD: time between when the Read ADDRESS is input and when the DATA is output	-	2.06 ns

Table 14: Input Register Cell

Symbol	Parameter: Input Cell Register Only	Value	
		Min	Max
t_{ISU}	Input register setup time: time the synchronous input of the flip flop must be stable before the active clock edge	3.12 ns	-
t_{IHL}	Input register hold time: time the synchronous input of the flip flop must be stable after the active clock edge	0 ns	-
t_{ICO}	Input register clock to out: time taken by the flip flop to output after the active clock edge	-	1.08 ns
t_{IRST}	Input register reset delay: time between when the flip flop is "reset"(low) and when the output is consequently "reset" (low)	-	0.99 ns
t_{IESU}	Input register clock enable setup time: time "enable" must be stable before the active clock edge	0.37 ns	-
t_{IEH}	Input register clock enable hold time: time "enable" must be stable after the active clock edge	0 ns	-

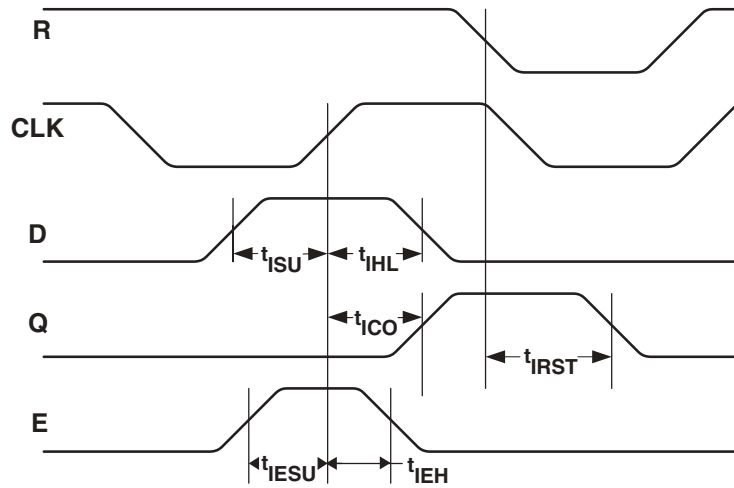

Figure 15: Input Register Cell

Table 15: Standard Input Delays

Symbol	Parameter To get the total input delay add this delay to t_{ISU}	Value	
		Min	Max
$t_{SID(LVTTL)}$	LVTTL input delay: Low Voltage TTL for 3.3V applications	-	0.34 ns
$t_{SID(LVCOS2)}$	LVCOS2 input delay: Low Voltage CMOS for 2.5V and lower applications	-	0.42 ns
$t_{SID(GTL+)}$	GTL+ input delay: Gunning Transceiver Logic	-	0.68 ns
$t_{SID(SSTL3)}$	SSTL3 input delay: Stub Series Terminated Logic for 3.3V	-	0.55 ns
$t_{SID(SSTL2)}$	SSTL2 input delay: Stub Series Terminated Logic for 2.5V	-	0.61 ns

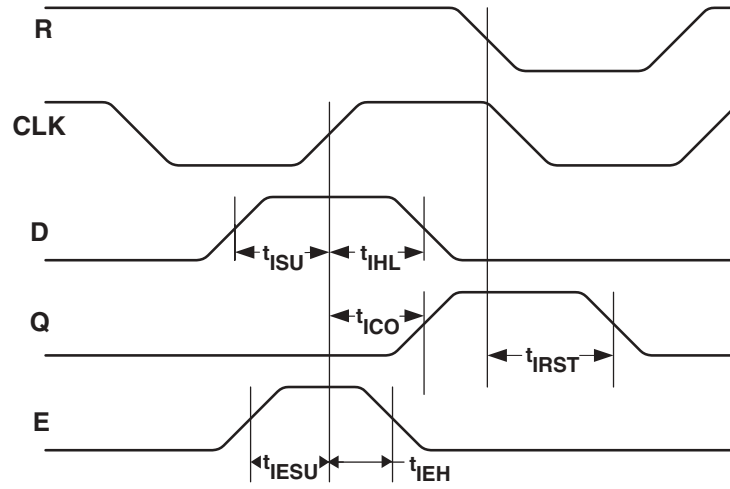

Figure 16: Input Register Cell Timing

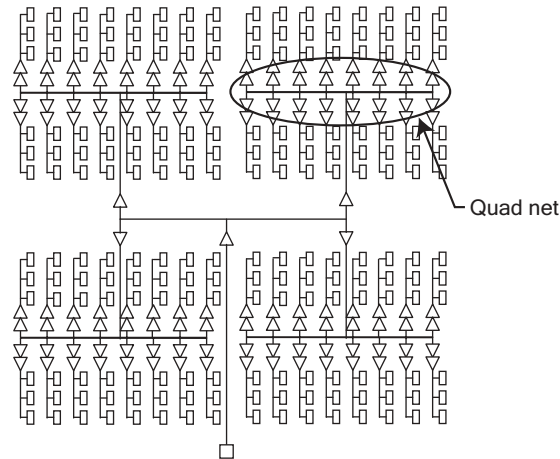

Figure 17: Global Clock Structure

Table 16: Eclipse Clock Performance

Clock	Parameters	Clock Performance	
		Global	Dedicated
Logic Cells (Internal)	Clock signal generated internally	1.51 ns (max)	1.59 ns (max)
I/O's (External)	Clock signal generated externally	2.06 ns (max)	1.73 ns (max)

Table 17: QL5732 Global Clock Performance

Clock Segment	Parameter	Value	
		Min	Max
t_{PGCK}	Global clock pin delay to quad net	-	1.34 ns
t_{BGCK}	Global clock buffer delay (quad net to flip flop)	-	0.56 ns

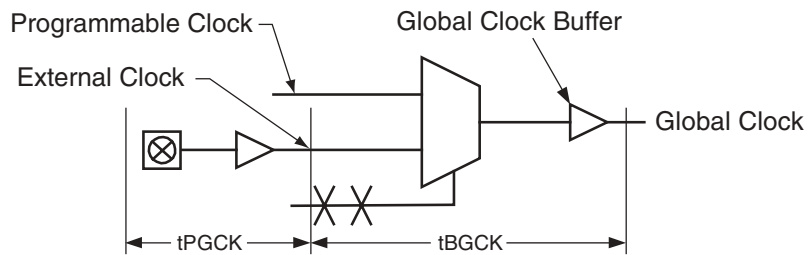

Figure 18: Global Clock Structure Schematic

Table 18: Output Register Cell

Symbol	Parameter: Output Register Cell Only	Min	Max
t_{OUTLH}	Output Delay low to high (90% of H)	-	0.40
t_{OUTHL}	Output Delay high to low (10% of L)	-	0.55
t_{PZH}	Output Delay tri-state to high (90% of H)	-	2.94
t_{PZL}	Output Delay tri-state to low (10% of L)	-	2.34
t_{PHZ}	Output Delay high to tri-State	-	3.07
t_{PLZ}	Output Delay low to tri-State	-	2.53
t_{COP}	Clock to out delay (does not include clock tree delays)	-	3.15 (fast slew) 10.2 (slow slew)

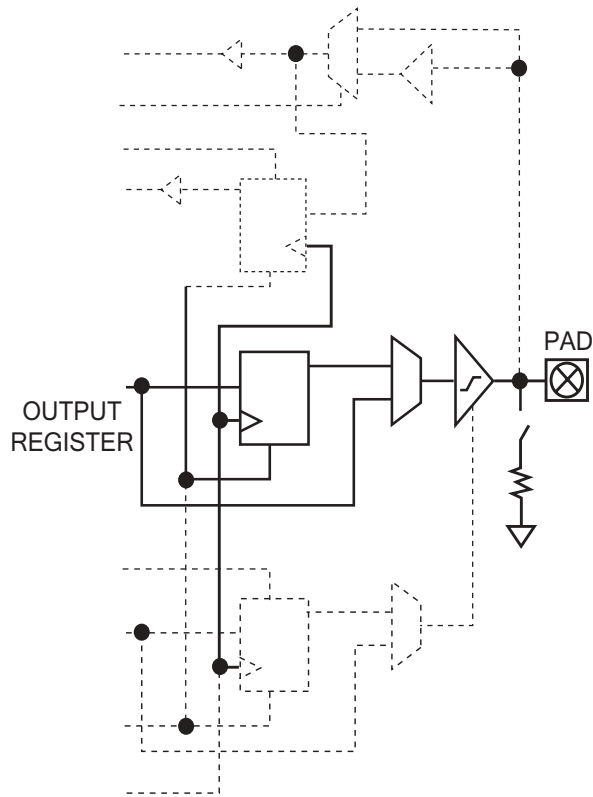

Figure 19: Output Register Cell

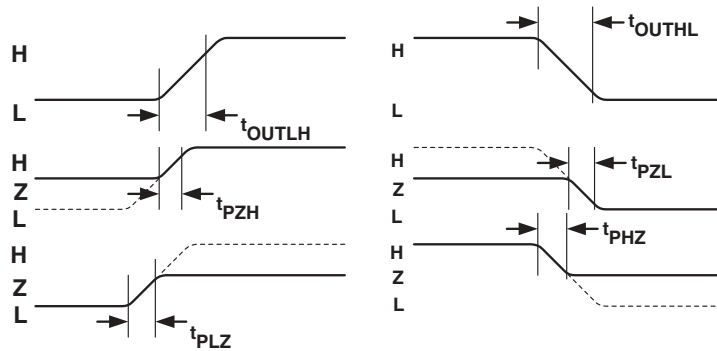

Figure 20: Output Register Cell Timing

Table 19: Output Slew Rates @ VCCIO = 3.3 V

	Fast Slew	Slow Slew
Rising Edge	2.8 V/ns	1.0 V/ns
Falling Edge	2.86 V/ns	1.0 V/ns

Table 20: Output Slew Rates @ $V_{CCIO} = 2.5\text{ V}$

	Fast Slew	Slow Slew
Rising Edge	1.7 V/ns	0.6 V/ns
Falling Edge	1.9 V/ns	0.6 V/ns

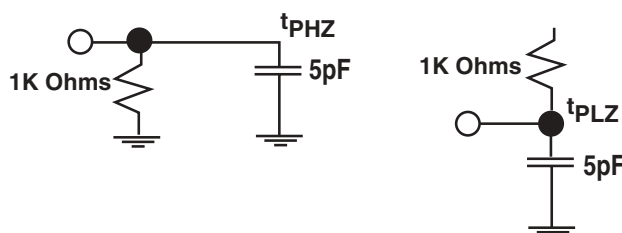

Figure 21: Loads for t_{pXZ}

Pin Type Descriptions

The QL5732 Device Pins are indicated in **Table 21**. Some of the pins presented in this table connect to the PCI bus, and others are programmable as user I/O.

Table 21: Pin Descriptions

Pin	Function	Description
TDI/RSI	Test Data In for JTAG /RAM init. Serial Data In	Hold HIGH during normal operation. Connects to serial PROM data in for RAM initialization. Connect to V_{CC} if unused
TRSTB/RRO	Active low Reset for JTAG /RAM init. reset out	Hold LOW during normal operation. Connects to serial PROM reset for RAM initialization. Connect to GND if unused
TMS	Test Mode Select for JTAG	Hold HIGH during normal operation. Connect to V_{CC} if not used for JTAG
TCK	Test Clock for JTAG	Hold HIGH or LOW during normal operation. Connect to V_{CC} or ground if not used for JTAG
TDO/RCO	Test data out for JTAG /RAM init. clock out	Connect to serial PROM clock for RAM initialization. Must be left unconnected if not used for JTAG or RAM initialization
I/GCLK	High-drive input and/or global clock network driver	Can be configured as either input or global clock
I/O	Input/Output pin	Can be configured as an input and/or output
V_{CC}	Power supply pin	Connect to 2.5 V supply
$V_{CCIO<PCI>}$	Input voltage tolerance pin	Connect to 3.3 V supply
$V_{CCIO<A>-<E>}$	Input voltage tolerance pin	Connect to 3.3 V supply if 3.3 V input tolerance is required; otherwise, connect to 2.5 V supply
GND	Ground pin	Connect to ground

Table 21: Pin Descriptions

Pin	Function	Description
PLLIN	PLL clock input	Clock input for PLL
DEDCLK	Dedicated clock pin	Low skew global clock
GNDPLL	Ground pin for PLL	Connect to GND
INREF	Differential reference voltage	Connect to reference voltage or ground if used for non-differential input
PLLOUT	PLL output pin	Dedicated PLL output pin. Otherwise may be left unconnected
IOCTRL	Highdrive input	Can be used as highdrive input or clock to I/O register within the same bank. Tied low or high if unused

484 PBGA Pinout Table

Table 22: 484 PBGA Pinout Table

484 PBGA	Function	484 PBGA	Function	484 PBGA	Function	484 PBGA	Function	484 PBGA	Function	484 PBGA	Function
A1	I/O<A>	C17	I/O<G>	F11	VCCIO<H>	J5	I/O<A>	L21	I/O<F>	P15	VCC
A2	PLL<3>	C18	AD[18]	F12	VCCIO<G>	J6	I/O<A>	L22	I/O<F>	P16	I/O<E>
A3	I/O<A>	C19	AD[23]	F13	AD[12]	J7	I/O<A>	M1	I/O	P17	I/O<E>
A4	I/O<A>	C20	GND<0>	F14	VCCIO<PCI>	J8	VCC	M2	I/O	P18	I/O<E>
A5	I/O<A>	C21	AD[27]	F15	N/C	J9	GND	M3	I/O	P19	I/O<E>
A6	I/O<H>	C22	AD[30]	F16	VCCIO<G>	J10	VCC	M4	CLK<3>/PLLIN<1>	P20	I/O<E>
A7	I/O<H>	D1	I/O<A>	F17	N/C	J11	VCC	M5	I/O	P21	I/O<E>
A8	IOCTRL<H>	D2	I/O<A>	F18	GNTN	J12	GND	M6	VCCIO	P22	I/O<E>
A9	AD[0]	D3	I/O<A>	F19	REQN	J13	VCC	M7	CLK<1>	R1	I/O
A10	N/C	D4	I/O<A>	F20	IOCTRL<F>	J14	GND	M8	VCC	R2	INREF
A11	N/C	D5	I/O<A>	F21	I/O<F>	J15	VCC	M9	VCC	R3	I/O
A12	TCK	D6	I/O<H>	F22	IOCTRL<F>	J16	AD[29]	M10	GND	R4	I/O
A13	AD[10]	D7	I/O<H>	G1	I/O<A>	J17	VCCIO<F>	M11	GND	R5	I/O
A14	AD[13]	D8	I/O<H>	G2	I/O<A>	J18	I/O<F>	M12	GND	R6	I/O
A15	SERRN	D9	I/O<H>	G3	I/O<A>	J19	I/O<F>	M13	GND	R7	I/O
A16	I/O<G>	D10	AD[4]	G4	I/O<A>	J20	I/O<F>	M14	GND	R8	GND
A17	IRDYN	D11	AD[7]	G5	I/O<A>	J21	I/O<F>	M15	GND	R9	VCC
A18	AD[17]	D12	AD[8]	G6	I/O<A>	J22	I/O<F>	M16	GND	R10	VCC
A19	AD[20]	D13	AD[14]	G7	GND	K1	TDI	M17	I/O<E>	R11	GND
A20	GND	D14	CBEN[1]	G8	I/O<H>	K2	I/O<A>	M18	I/O<E>	R12	VCC
A21	PLLOUT<3>	D15	IOCTRL<G>	G9	I/O<H>	K3	I/O<A>	M19	I/O<E>	R13	VCC
A22	IDSEL	D16	CBEN[2]	G10	I/O<H>	K4	I/O<A>	M20	CLK<7>	R14	VCC
B1	I/O<A>	D17	AD[16]	G11	CBEN[0]	K5	I/O<A>	M21	CLK<5>/PLLIN<3>	R15	GND
B2	GND	D18	AD[22]	G12	GND	K6	VCCIO<A>	M22	TMS	R16	I/O<D>
B3	GND<3>	D19	VCC<0>	G13	I/O<G>	K7	I/O<A>	N1	I/O	R17	VCCIO<E>
B4	GND	D20	AD[26]	G14	I/O<G>	K8	VCC	N2	I/O	R18	I/O<E>
B5	I/O<A>	D21	AD[31]	G15	PAR	K9	VCC	N3	I/O	R19	I/O<E>
B6	I/O<H>	D22	RSTN	G16	GND	K10	GND	N4	I/O	R20	I/O<E>
B7	I/O<H>	E1	IOCTRL<A>	G17	VCCIO<F>	K11	GND	N5	I/O	R21	I/O<E>
B8	INREF<H>	E2	I/O<A>	G18	I/O<F>	K12	GND	N6	I/O	R22	I/O<E>
B9	I/O<H>	E3	I/O<A>	G19	I/O<F>	K13	GND	N7	I/O	T1	I/O
B10	AD[3]	E4	I/O<A>	G20	I/O<F>	K14	VCC	N8	VCC	T2	I/O
B11	AD[6]	E5	I/O<A>	G21	INREF<F>	K15	VCC	N9	VCC	T3	I/O
B12	N/C	E6	I/O<H>	G22	I/O<F>	K16	I/O<F>	N10	GND	T4	I/O
B13	N/C	E7	N/C	H1	I/O<A>	K17	I/O<F>	N11	GND	T5	I/O
B14	N/C	E8	I/O<H>	H2	I/O<A>	K18	I/O<F>	N12	GND	T6	VCCIO
B15	I/O<G>	E9	I/O<H>	H3	I/O<A>	K19	I/O<F>	N13	GND	T7	GND
B16	DEVSELN	E10	AD[5]	H4	I/O<A>	K20	I/O<F>	N14	VCC	T8	I/O<C>
B17	FRAMEN	E11	VCC	H5	IOCTRL<A>	K21	I/O<F>	N15	VCC	T9	N/C
B18	AD[19]	E12	AD[9]	H6	VCCIO<A>	K22	I/O<F>	N16	I/O<E>	T10	TRSTB
B19	PLL<0>	E13	AD[15]	H7	I/O<H>	L1	CLK<4>-DEDCLK/ PLLIN<0>	N17	VCCIO<E>	T11	GND
B20	CBEN[3]	E14	AD[13]	H8	GND	L2	CLK<0>	N18	I/O<E>	T12	N/C
B21	AD[24]	E15	IOCTRL<G>	H9	VCC	L3	CLK<2>/PLLIN<2>	N19	I/O<E>	T13	I/O<D>
B22	AD[28]	E16	STOPN	H10	VCC	L4	I/O<A>	N20	I/O<E>	T14	N/C
C1	I/O<A>	E17	INREF<G>	H11	VCC	L5	I/O<A>	N21	I/O<E>	T15	I/O<D>
C2	I/O<A>	E18	I/O<G>	H12	GND	L6	I/O<A>	N22	I/O<E>	T16	GND
C3	VCC<3>	E19	AD[25]	H13	VCC	L7	GND	P1	I/O	T17	I/O<E>
C4	PLLOUT<2>	E20	I/O<F>	H14	VCC	L8	GND	P2	I/O	T18	I/O<E>
C5	I/O<A>	E21	I/O<F>	H15	GND	L9	GND	P3	I/O	T19	I/O<E>

(Sheet 1 of 2)

Table 22: 484 PBGA Pinout Table (Continued)

484 PBGA	Function	484 PBGA	Function	484 PBGA	Function	484 PBGA	Function	484 PBGA	Function	484 PBGA	Function
C6	I/O<H>	E22	I/O<F>	H16	AD[21]	L10	GND	P4	I/O	T20	I/O<E>
C7	I/O<H>	F1	I/O<A>	H17	I/O<F>	L11	GND	P5	I/O	T21	IOCTRL<E>
C8	I/O<H>	F2	INREF<A>	H18	I/O<F>	L12	GND	P6	VCCIO	T22	I/O<E>
C9	IOCTRL<H>	F3	I/O<A>	H19	I/O<F>	L13	GND	P7	I/O	U1	IOCTRL
C10	I/O<H>	F4	I/O<A>	H20	I/O<F>	L14	VCC	P8	VCC	U2	I/O
C11	AD[2]	F5	I/O<A>	H21	I/O<F>	L15	VCC	P9	GND	U3	IOCTRL
C12	I/O<H>	F6	VCCIO<A>	H22	I/O<F>	L16	CLK<6>	P10	VCC	U4	I/O
C13	AD[11]	F7	VCCIO<H>	J1	I/O<A>	L17	VCCIO<F>	P11	GND	U5	I/O
C14	I/O<G>	F8	I/O<H>	J2	I/O<A>	L18	I/O<F>	P12	VCC	U6	I/O<C>
C15	PERRN	F9	VCCIO<H>	J3	I/O<A>	L19	(PCI)CLK	P13	VCC	U7	VCCIO<C>
C16	TRDYN	F10	AD[1]	J4	I/O<A>	L20	I/O<F>	P14	GND	U8	N/C
U9	VCCIO<C>	V8	I/O<C>	W7	N/C	Y6	I/O<C>	AA5	I/O<C>	AB4	I/O
U10	I/O<C>	V9	N/C	W8	I/O<C>	Y7	I/O<C>	AA6	I/O<C>	AB5	I/O
U11	VCCIO<C>	V10	I/O<C>	W9	I/O<C>	Y8	IOCTRL<C>	AA7	I/O<C>	AB6	I/O<C>
U12	VCCIO<D>	V11	I/O<C>	W10	I/O<C>	Y9	I/O<C>	AA8	INREF<C>	AB7	I/O<C>
U13	I/O<D>	V12	VCC	W11	I/O<C>	Y10	I/O<C>	AA9	I/O<C>	AB8	IOCTRL<C>
U14	VCCIO<D>	V13	N/C	W12	I/O<D>	Y11	I/O<D>	AA10	I/O<C>	AB9	I/O<C>
U15	N/C	V14	I/O<D>	W13	I/O<D>	Y12	I/O<D>	AA11	I/O<C>	AB10	I/O<C>
U16	VCCIO<D>	V15	I/O<D>	W14	I/O<D>	Y13	I/O<D>	AA12	I/O<D>	AB11	I/O<C>
U17	VCCIO<E>	V16	INREF<D>	W15	I/O<D>	Y14	I/O<D>	AA13	I/O<D>	AB12	I/O<D>
U18	I/O<E>	V17	I/O<D>	W16	N/C	Y15	IOCTRL<D>	AA14	I/O<D>	AB13	I/O<D>
U19	I/O<E>	V18	I/O<E>	W17	I/O<D>	Y16	I/O<D>	AA15	I/O<D>	AB14	I/O<D>
U20	IOCTRL<E>	V19	I/O<E>	W18	I/O<E>	Y17	I/O<D>	AA16	I/O<D>	AB15	I/O<D>
U21	I/O<E>	V20	I/O<E>	W19	I/O<E>	Y18	I/O<E>	AA17	I/O<D>	AB16	IOCTRL<D>
U22	INREF<E>	V21	I/O<E>	W20	I/O<E>	Y19	PLLOUT<0>	AA18	I/O<D>	AB17	I/O<D>
V1	I/O	V22	I/O<E>	W21	I/O<E>	Y20	PLLST<1>	AA19	I/O<E>	AB18	I/O<D>
V2	I/O	W1	I/O	W22	I/O<E>	Y21	I/O<E>	AA20	GNDPLL<1>	AB19	I/O<E>
V3	I/O	W2	I/O	Y1	I/O	Y22	I/O<E>	AA21	I/O<E>	AB20	GND
V4	I/O	W3	I/O	Y2	I/O	AA1	TDO	AA22	I/O<E>	AB21	VCCPLL<1>
V5	I/O	W4	I/O	Y3	VCCPLL<2>	AA2	PLLOUT<1>	AB1	I/O	AB22	I/O<E>
V6	I/O<C>	W5	I/O	Y4	I/O<C>	AA3	GND	AB2	GNDPLL<2>		
V7	I/O<C>	W6	I/O<C>	Y5	I/O<C>	AA4	I/O	AB3	PLLST<2>		

(Sheet 2 of 2)

NOTE: Pinout table has changed from Rev. B to Rev. C.

484 PBGA Pinout Diagrams

Top



Figure 22: 484 PBGA Pinout Diagrams

Bottom

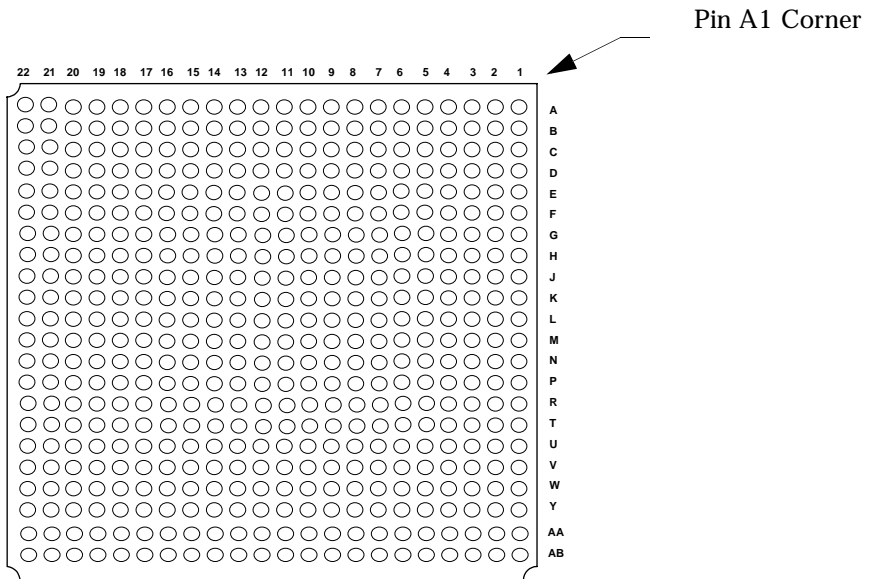
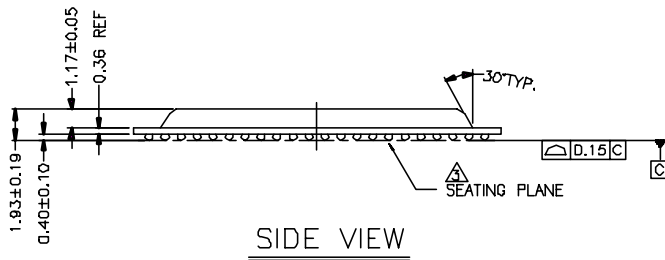
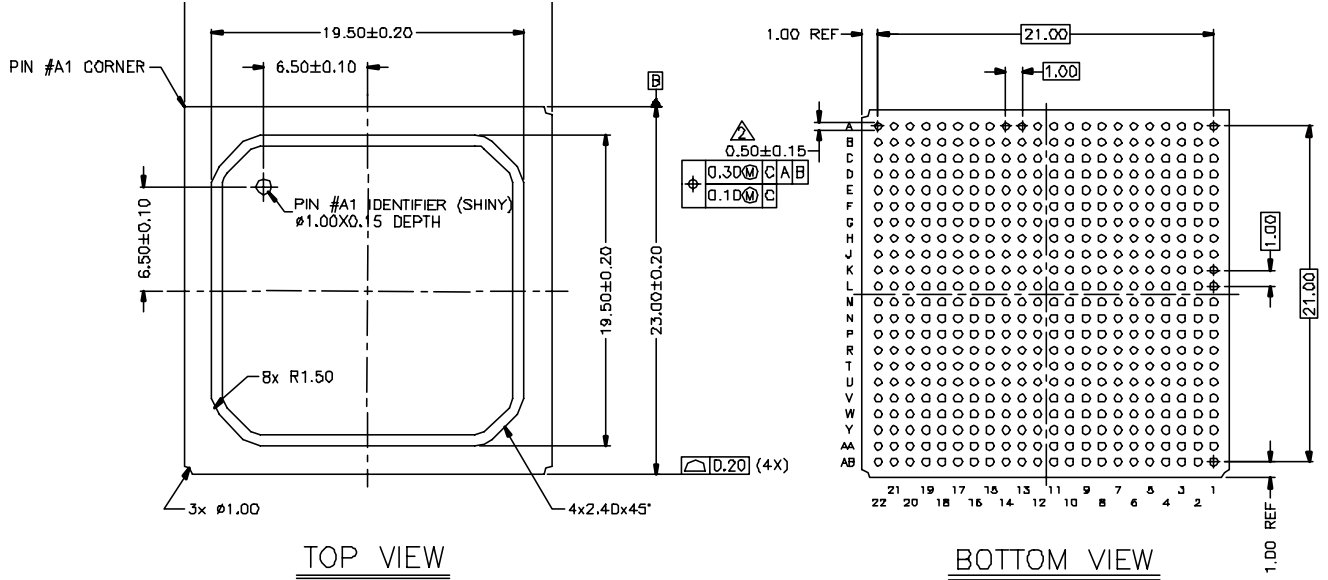
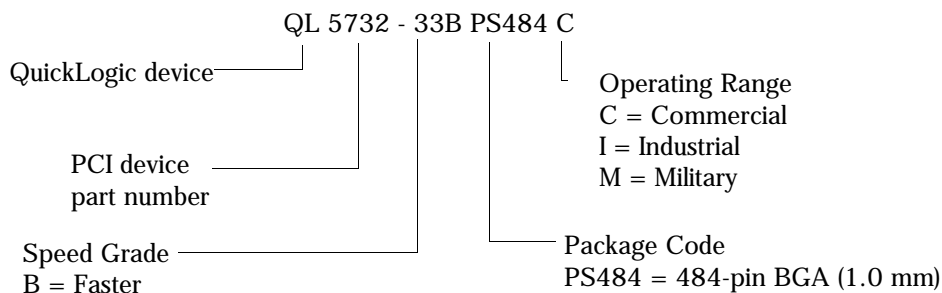

Figure 23: 484 PBGA Pinout Diagram

484 PBGA Packaging Drawing



Ordering Information



Revision History

Table 23: Revision History

Revision	Date	Originator and Comments
Rev. A	September 2002	Bernhard Andretzky, Stacy Joseph, Andreea Rotaru
Rev. B	January 2003	Bernhard Andretzky, Andreea Rotaru
Rev. C	February 2003	Bernhard Andretzky, Kathleen Murchek

Copyright and Trademark Information

Copyright © 2003 QuickLogic Corporation.
All Rights Reserved.

The information contained in this document and the accompanying software programs is protected by copyright. All rights are reserved by QuickLogic Corporation. QuickLogic Corporation reserves the right to modify this document without any obligation to notify any person or entity of such revision. Copying, duplicating, selling, or otherwise distributing any part of this product without the prior written consent of an authorized representative of QuickLogic is prohibited.

QuickLogic and the QuickLogic logo, pASIC, ViaLink, DeskFab, and QuickWorks are registered trademarks of QuickLogic Corporation; Eclipse, QuickFC, QuickDSP, QuickDR, QuickSD, QuickTools, QuickCore, QuickPro, SpDE, WebASIC, and WebESP are trademarks of QuickLogic Corporation.

Contact Information

Telephone: 408 990 4000 (US)
416 497 8884 (Canada)
44 1932 57 9011 (Europe)
49 89 930 86 170 (Germany)
852 8106 9091 (Asia)
81 45 470 5525 (Japan)

E-mail: info@quicklogic.com

Support: support@quicklogic.com

Web site: <http://www.quicklogic.com/>