

●●●●● FPGA Combining Performance, Density, and Embedded RAM

Device Highlights

Flexible Programmable Logic

- 0.18 μm six layer metal CMOS Process
- 1.8/2.5/3.3 V Drive Capable I/O
- 1,536 Logic Cells
- 320,640 Max System Gates
- Up to 310 I/O Pins

Embedded Dual Port SRAM

- Twenty-four 2,304-bit Dual Port High Performance SRAM Blocks
- 55,300 RAM bits
- RAM/ROM/FIFO Wizard for Automatic Configuration
- Configurable and Cascadable

Programmable I/O

- High performance Enhanced I/O (EIO)—less than 3 ns Tco
- Programmable Slew Rate Control
- Programmable I/O Standards:
 - LVTTTL, LVCMOS, PCI, GTL+, SSTL2, and SSTL3
 - Eight Independent I/O Banks
 - Three Register Configurations: Input, Output, and Output Enable

Advanced Clock Network

- Nine Global Clock Networks:
 - One Dedicated
 - Eight Programmable
- 20 Quad-Net Networks—five per Quadrant
- 16 I/O Controls—two per I/O Bank
- Four phase locked loops

Embedded Computational Units

12 ECUs provide integrated Multiply, Add, and Accumulate Functions.

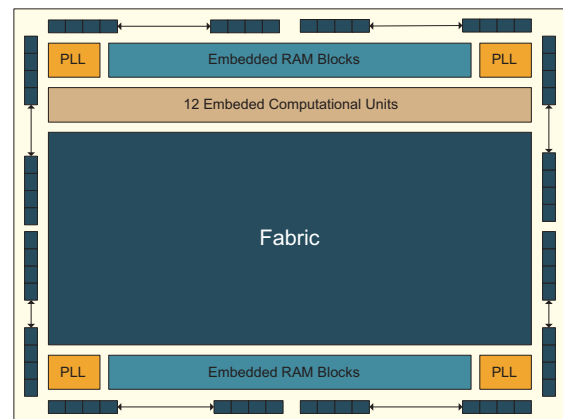

Figure 1: QL6325-E Eclipse-E Block Diagram

Electrical Specifications

AC Characteristics*

*at $V_{CC} = 2.5\text{ V}$, $T_A = 25^\circ\text{ C}$, Worst Case Corner, Speed Grade = -7 (K = 1.16)

The AC Specifications are provided from **Table 1** to **Table 10**. Logic Cell diagrams and waveforms are provided from **Figure 2** to **Figure 15**.

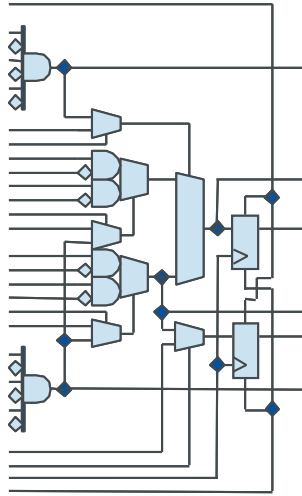

Figure 2: Eclipse-E Logic Cell

Table 1: Logic Cells

Symbol Logic Cells	Parameter	Value	
		Min	Max
t_{PD}	Combinatorial Delay of the longest path: time taken by the combinatorial circuit to output	-	0.257 ns
t_{SU}	Setup time: time the synchronous input of the flip-flop must be stable before the active clock edge	0.22 ns	-
t_{HL}	Hold time: time the synchronous input of the flip-flop must be stable after the active clock edge	0 ns	-
t_{CO}	Clock-to-out delay: the amount of time taken by the flip-flop to output after the active clock edge.	-	0.255 ns
t_{CWHI}	Clock High Time: required minimum time the clock stays high	0.46 ns	-
t_{CWLO}	Clock Low Time: required minimum time that the clock stays low	0.46 ns	-
t_{SET}	Set Delay: time between when the flip-flop is "set" (high) and when the output is consequently "set" (high)	-	0.18 ns

Table 1: Logic Cells (Continued)

Symbol Logic Cells	Parameter	Value	
		Min	Max
t_{RESET}	Reset Delay: time between when the flip-flop is "reset" (low) and when the output is consequently "reset" (low)	-	0.09 ns
t_{SW}	Set Width: time that the SET signal remains high/low	0.3 ns	-
t_{RW}	Reset Width: time that the RESET signal remains high/low	0.3 ns	-

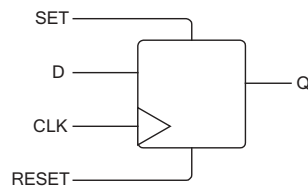

Figure 3: Logic Cell Flip-Flop

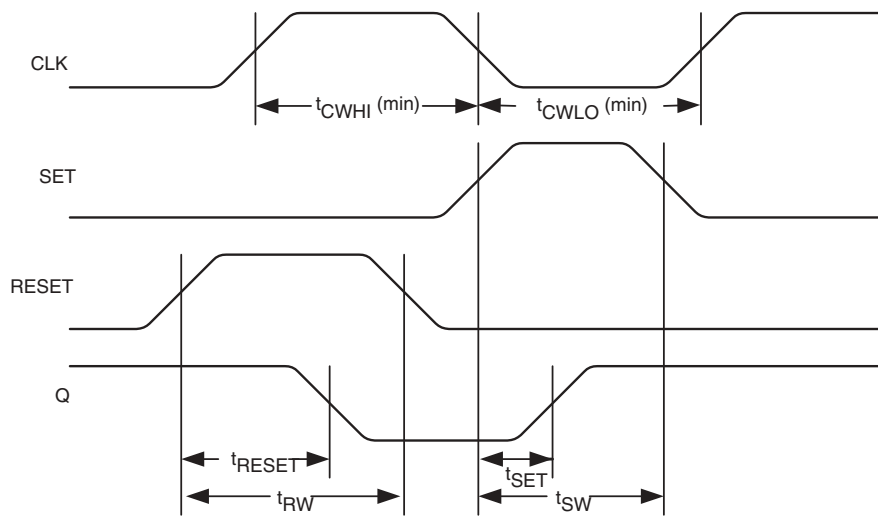

Figure 4: Logic Cell Flip-Flop Timings—First Waveform

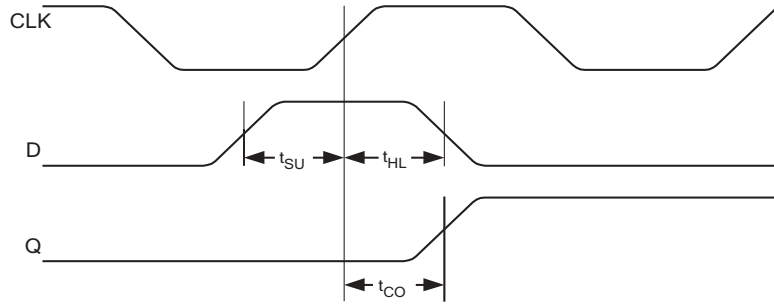

Figure 5: Logic Cell Flip-Flop Timings—Second Waveform

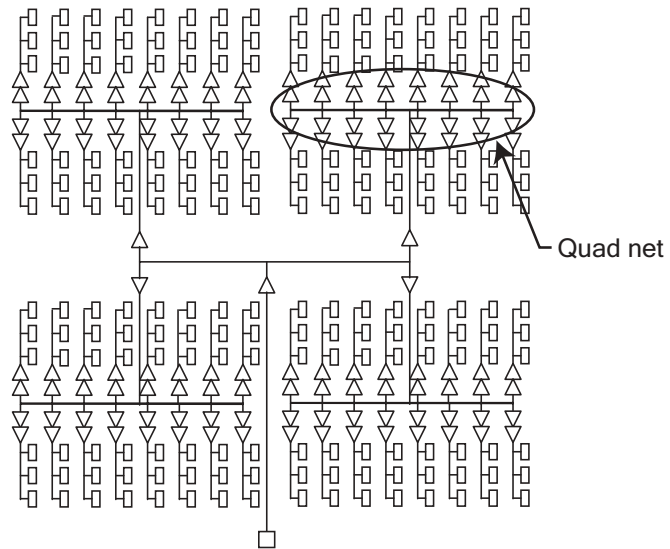

Figure 6: Eclipse-E Global Clock Structure

Table 2: Eclipse-E Clock Delay

Clock Source	Parameters	Clock Performance	
		Global	Dedicated
Logic Cells (Internal)	Clock signal generated internally	1.51 ns (max)	
Clock Pad	Clock signal generated externally	2.06 ns (max)	1.73 ns (max)

Table 3: Eclipse-E Global Clock Delay

Clock Segment	Parameter	Value	
		Min	Max
t_{PGCK}^a	Global clock pin delay to quad net	-	1.34 ns
t_{BGCK}	Global clock tree delay (quad net to flip-flop)	-	0.56 ns

a. When using a PLL, t_{PGCK} and t_{BGCK} are effectively zero due to delay adjustment by Phase Locked Loop.

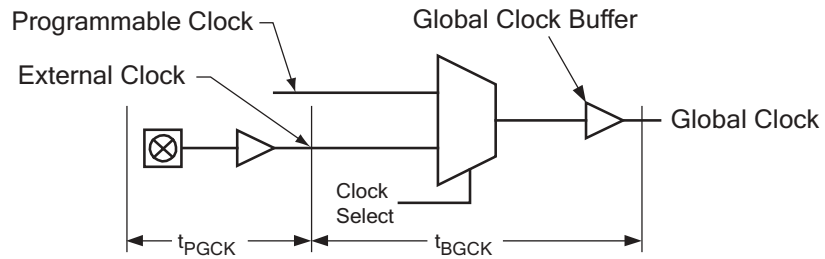

Figure 7: Global Clock Structure Schematic

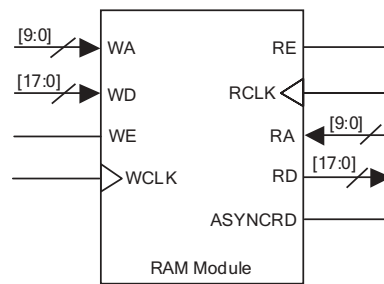

Figure 8: RAM Module

Table 4: RAM Cell Synchronous Write Timing

Symbol	Parameter	Value	
		Min	Max
RAM Cell Synchronous Write Timing			
t_{SWA}	WA setup time to WCLK: time the WRITE ADDRESS must be stable before the active edge of the WRITE CLOCK	0.675 ns	-
t_{HWA}	WA hold time to WCLK: time the WRITE ADDRESS must be stable after the active edge of the WRITE CLOCK	0 ns	-
t_{SWD}	WD setup time to WCLK: time the WRITE DATA must be stable before the active edge of the WRITE CLOCK	0.654 ns	-
t_{HWD}	WD hold time to WCLK: time the WRITE DATA must be stable after the active edge of the WRITE CLOCK	0 ns	-
t_{SWE}	WE setup time to WCLK: time the WRITE ENABLE must be stable before the active edge of the WRITE CLOCK	0.623 ns	-
t_{HWE}	WE hold time to WCLK: time the WRITE ENABLE must be stable after the active edge of the WRITE CLOCK	0 ns	-
t_{WCRD}	WCLK to RD (WA = RA): time between the active WRITE CLOCK edge and the time when the data is available at RD	-	4.38 ns

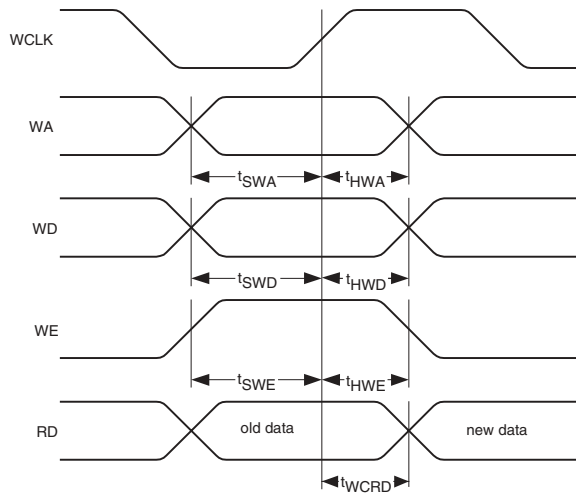

Figure 9: RAM Cell Synchronous Write Timing

Table 5: RAM Cell Synchronous & Asynchronous Read Timing

Symbol	RAM Cell Synchronous Read Timing Parameter	Value	
		Min	Max
t_{SRA}	RA setup time to RCLK: time the READ ADDRESS must be stable before the active edge of the READ CLOCK	0.686 ns	-
t_{HRA}	RA hold time to RCLK: time the READ ADDRESS must be stable after the active edge of the READ CLOCK	0 ns	-
t_{SRE}	RE setup time to WCLK: time the READ ENABLE must be stable before the active edge of the READ CLOCK	0.243 ns	-
t_{HRE}	RE hold time to WCLK: time the READ ENABLE must be stable after the active edge of the READ CLOCK	0 ns	-
t_{RCRD}	RCLK to RD: time between the active READ CLOCK edge and the time when the data is available at RD	-	4.38 ns
RAM Cell Asynchronous Read Timing			
t_{PDRD}	RA to RD: time between when the READ ADDRESS is input and when the DATA is output	-	2.06 ns

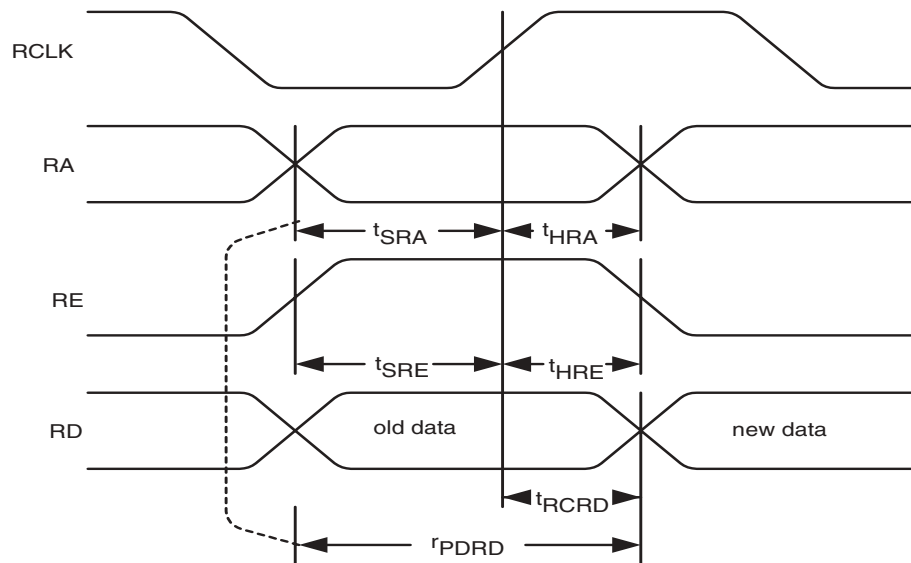

Figure 10: RAM Cell Synchronous & Asynchronous Read Timing

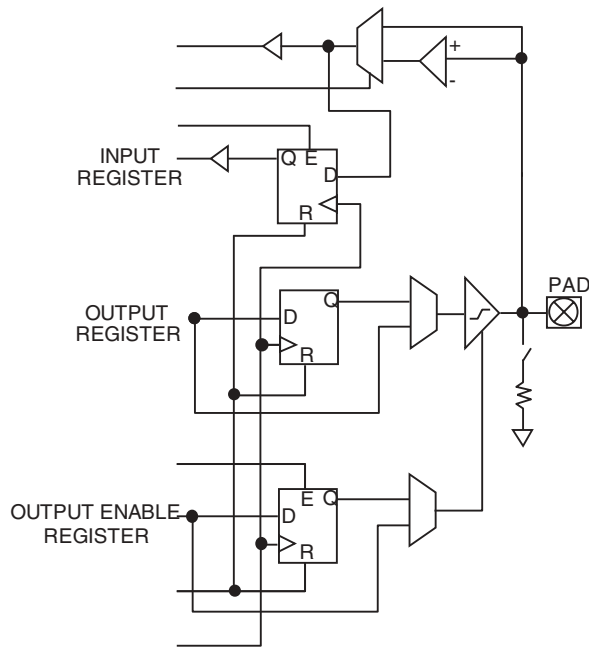

Figure 11: Eclipse-E Cell I/O

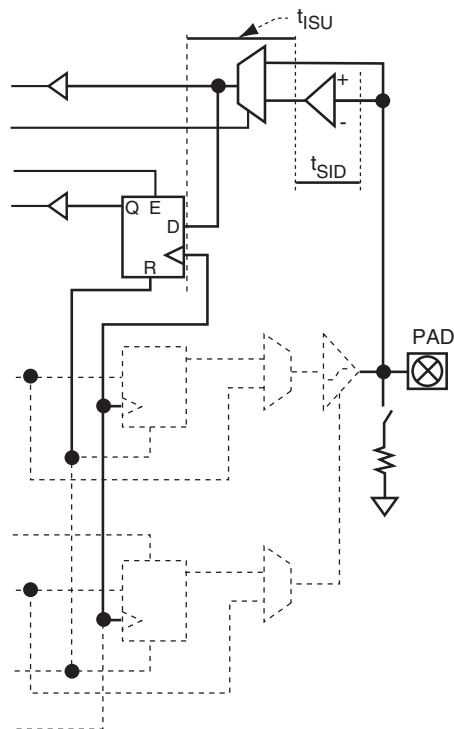

Figure 12: Eclipse-E Input Register Cell

Table 6: Input Register Cell

Symbol	Parameter: Input Register Cell Only	Value	
		Min	Max
t_{ISU}	Input register setup time: the time the synchronous input of the flip-flop must be stable before the active clock edge	2.50 ns	-
t_{IHL}	Input register hold time: the time the synchronous input of the flip-flop must be stable after the active clock edge	0 ns	-
t_{ICO}	Input register clock-to-out: the time taken by the flip-flop to output after the active clock edge	-	1.08 ns
t_{IRST}	Input register reset delay: the time between when the flip-flop is “reset”(low) and when the output is consequently “reset” (low)	-	0.99 ns
t_{IESU}	Input register clock enable setup time: the time “enable” must be stable before the active clock edge	0.37 ns	-
t_{IEH}	Input register clock enable hold time: the time “enable” must be stable after the active clock edge	0 ns	-

Table 7: Standard Input Delays

Symbol	Parameter	Value	
		Min	Max
Standard Input Delays	To get the total input delay add this delay to t_{ISU}		
t_{SID} (LVTTTL)	LVTTTL input delay: Low Voltage TTL for 3.3 V applications	-	0.34 ns
t_{SID} (LVCMOS2)	LVCMOS2 input delay: Low Voltage CMOS for 2.5 V and lower applications	-	0.42 ns
t_{SID} (LVCMOS18)	LVCMOS18 input delay: Low Voltage CMOS for 1.8 V applications	-	-
t_{SID} (GTL+)	GTL+ input delay: Gunning Transceiver Logic	-	0.68 ns
t_{SID} (SSTL3)	SSTL3 input delay: Stub Series Terminated Logic for 3.3 V	-	0.55 ns
t_{SID} (SSTL2)	SSTL2 input delay: Stub Series Terminated Logic for 2.5 V	-	0.61 ns

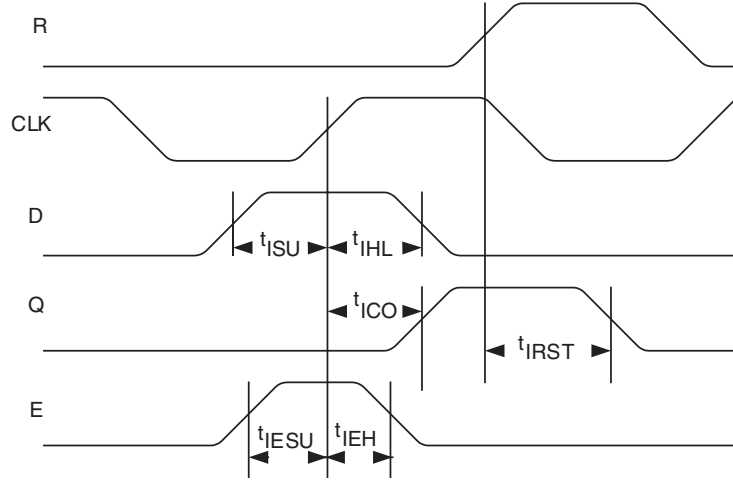

Figure 13: Eclipse-E Input Register Cell Timing

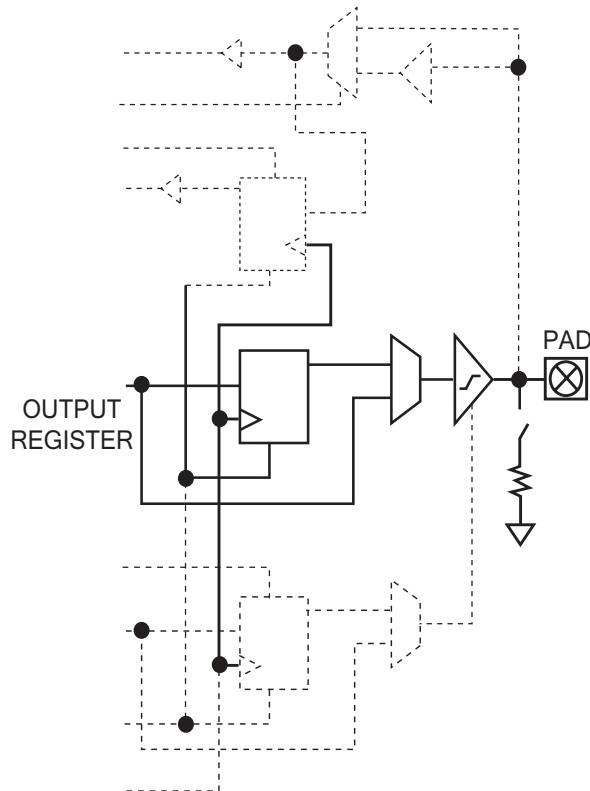

Figure 14: Eclipse-E Output Register Cell

Table 8: Eclipse-E Output Register Cell

Symbol	Parameter	Value	
		Min	Max
Output Register Cell Only			
t_{OUTLH}	Output Delay low to high (90% of H)	-	0.40 ns
t_{OUTHL}	Output Delay high to low (10% of L)	-	0.55 ns
t_{PZH}	Output Delay tri-state to high (90% of H)	-	2.94 ns
t_{PZL}	Output Delay tri-state to low (10% of L)	-	2.34 ns
t_{PHZ}	Output Delay high to tri-State	-	3.07 ns
t_{PLZ}	Output Delay low to tri-State	-	2.53 ns
t_{COP}	Clock-to-out delay (does not include clock tree delays)	-	3.15 ns (fast slew) 10.2 ns (slow slew)

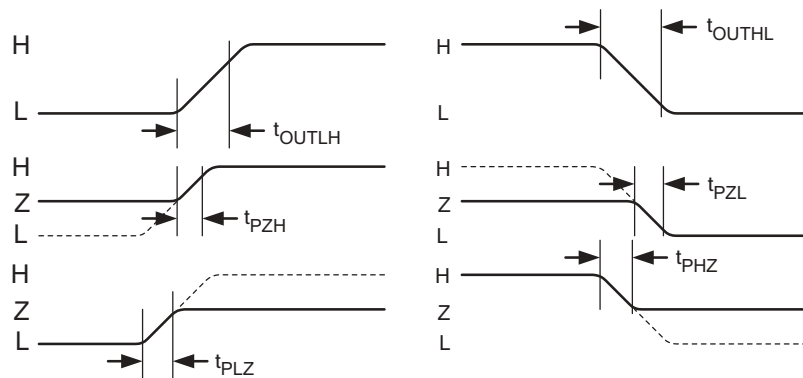

Figure 15: Eclipse-E Output Register Cell Timing

Table 9: Output Slew Rates @ $V_{CCIO} = 3.3\text{ V}$

	Fast Slew	Slow Slew
Rising Edge	2.8 V/ns	1.0 V/ns
Falling Edge	2.86 V/ns	1.0 V/ns

Table 10: Output Slew Rates @ $V_{CCIO} = 2.5\text{ V}$

	Fast Slew	Slow Slew
Rising Edge	1.7 V/ns	0.6 V/ns
Falling Edge	1.9 V/ns	0.6 V/ns

Table 11: Output Slew Rates @Vccio = 1.8 V

	Fast Slew	Slow Slew
Rising Edge	- V/ns	- V/ns
Falling Edge	- V/ns	- V/ns

DC Characteristics

The DC Specifications are provided in **Table 12** through **Table 14**.

Table 12: Absolute Maximum Ratings

Parameter	Value	Parameter	Value
V _{CC} Voltage	-0.5 V to 3.6 V	DC Input Current	±20 mA
V _{CCIO} Voltage	-0.5 V to 4.6 V	ESD Pad Protection	±2000 V
INREF Voltage	2.7 V	Leaded Package Storage Temperature	-65° C to + 150° C
Input Voltage	-0.5 V to V _{CCIO} +0.5 V	Laminate Package (BGA) Storage Temperature	-55° C to + 125° C
Latch-up Immunity	±100 mA		

Table 13: Operating Range

Symbol	Parameter	Military		Industrial		Commercial		Unit	
		Min	Max	Min	Max	Min	Max		
V _{CC}	Supply Voltage	2.3	2.7	2.3	2.7	2.3	2.7	V	
V _{CCIO}	I/O Input Tolerance Voltage	1.62	3.6	1.62	3.6	1.62	3.6	V	
TA	Ambient Temperature	-55		-40	85	0	70	°C	
TC	Case Temperature	-	125	-	-	-	-	°C	
K	Delay Factor	-6 Speed Grade	0.42	1.35	0.43	1.26	0.46	1.23	n/a
		-7 Speed Grade	0.42	1.27	0.43	1.19	0.46	1.16	n/a

Table 14: DC Characteristics

Symbol	Parameter	Conditions	Min	Max	Units
I _I	I or I/O Input Leakage Current	V _I = V _{CCIO} or GND	-10	10	µA
I _{OZ}	3-State Output Leakage Current	V _I = V _{CCIO} or GND	-10	10	µA
C _I	Input Capacitance ^a	-	-	8	pF
I _{OS}	Output Short Circuit Current ^b	V _o = GND	-15	-180	mA
		V _o = V _{CC}	40	210	mA
I _{CC}	D.C. Supply Current ^c	V _I , V _o = V _{CCIO} or GND	-	10	mA
I _{CCIO}	D.C. Supply Current on V _{CCIO}	-	0	2	mA
I _{CCIO(DIF)}	D.C. Supply Current on V _{CCIO} for Differential I/O	-	-	-	mA
I _{REF}	D.C. Supply Current on INREF	-	-10	10	µA
I _{PD}	Pad Pull-down (programmable)	V _{CCIO} = 3.6 V	-	150	µA

- a. Capacitance is sample tested only. Clock pins are 12 pF maximum.
 b. Only one output at a time. Duration should not exceed 30 seconds.
 c. For -6/-7 commercial grade devices only. Maximum I_{CC} is 15 mA for all industrial grade devices, and 25 mA for all military grade devices.

Embedded Computational Unit (ECU)

Traditional Programmable Logic architectures do not implement arithmetic functions efficiently or effectively—these functions require high logic cell usage while garnering only moderate performance results.

The QL6325-E architecture allows for functionality above and beyond that achievable using programmable logic devices. By embedding a dynamically reconfigurable computational unit, the QL6325-E device can address various arithmetic functions efficiently. This approach offers greater performance than traditional programmable logic implementations. The embedded block is implemented at the transistor level as shown in **Figure 16**.

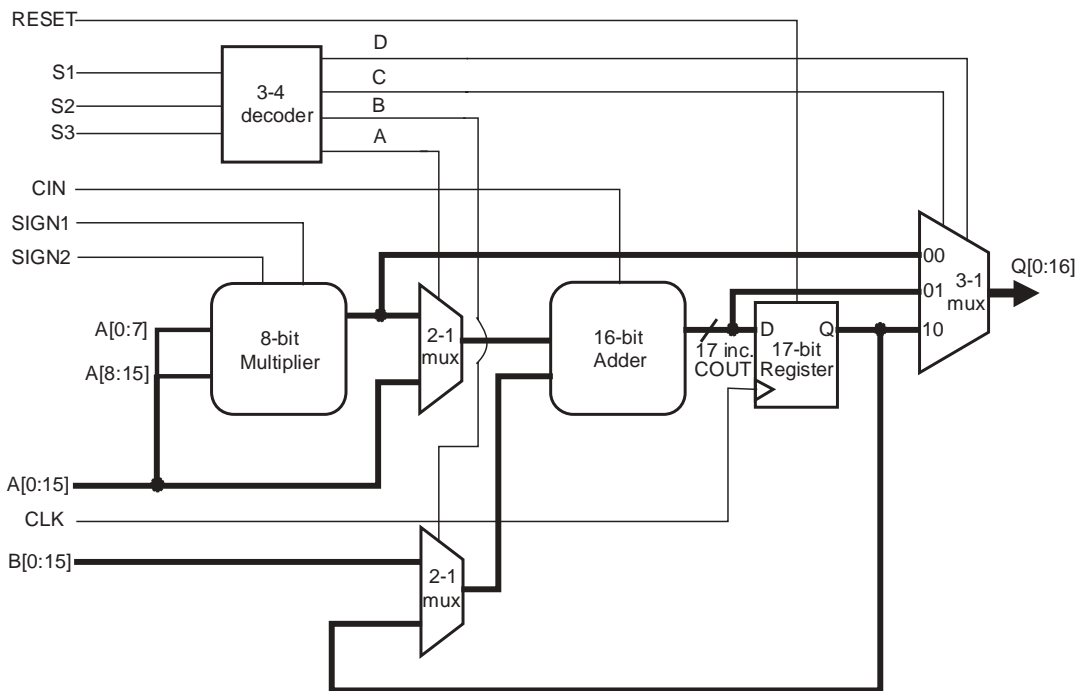

Figure 16: ECU Block Diagram

The 12 QL6325-E ECU blocks are placed next to the SRAM circuitry for efficient memory/instruction fetch and addressing for DSP algorithmic implementations.

Twelve 8-bit Multiply-Accumulate (MAC) functions can be implemented per cycle for a total of 1.2 billion MACs when clocked at 100 MHz. Additional MAC functions can be implemented in the programmable logic.

The modes for the ECU block are dynamically re-programmable through the programmable logic as shown in **Table 15**.

Table 15: ECU Mode Select Criteria

TABLE 16.

Instruction			Operation	ECU Performance ^a , -7 WCC ^b		
S1	S2	S3		t _{PD}	t _{SU}	t _{CO}
0	0	0	Multiply	6.57 ns max		
0	0	1	Multiply-Add	8.84 ns max		
0	1	0	Accumulate ^c		3.91 ns min	1.16 ns max
0	1	1	Add	3.14 ns max		
1	0	0	Multiply (registered) ^d		9.61 ns min	1.16 ns max
1	0	1	Multiply- Add (registered)		9.61 ns min	1.16 ns max
1	1	0	Multiply - Accumulate		9.61 ns min	1.16 ns max
1	1	1	Add (registered)		3.91 ns min	1.16 ns max

- a. t_{PD}, t_{SU} and t_{CO} do not include routing paths in/out of the ECU block.
- b. Timing numbers represent -7 Worst Case Commercial conditions.
- c. Internal feedback path in ECU restricts max clk frequency to 238 MHz.
- d. B [15:0] set to zero.

Phase Locked Loops (PLLs)

Instead of requiring extra components, designers simply need to instantiate one of the pre-configured models described in this section and listed in [Table](#) . The QuickLogic built-in PLLs support a wider range of frequencies than many other PLLs. Also, QuickLogic PLLs can be cascaded to support different ranges of frequency multiplications or divisions, driving the device at a faster or slower rate than the incoming clock frequency. Most importantly, they achieve a very short clock-to-out time—generally less than 3 ns. This low clock-to-out time is achieved by the PLL subtracting the clock tree delay through the feedback path, effectively making the clock tree delay zero.

[Figure 17](#) illustrates a typical QuickLogic FPGA PLL.

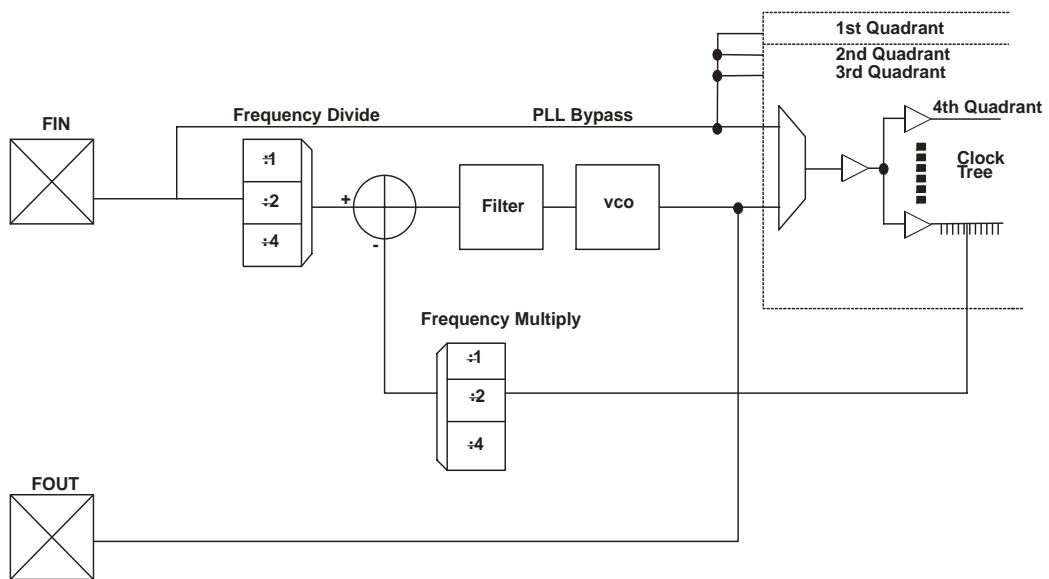

Figure 17: PLL Block

F_{in} represents a very stable high-frequency input clock and produces an accurate signal reference. This signal can either bypass the PLL entirely, thus entering the clock tree directly, or it can pass through the PLL itself.

Within the PLL, a voltage-controlled oscillator (VCO) is added to the circuit. The external F_{in} signal and the local VCO form a control loop. The VCO is multiplied or divided down to the reference frequency, so that a phase detector (the crossed circle in [Figure 17](#)) can compare the two signals. If the phases of the external and local signals are not within the tolerance required, the phase detector sends a signal through the charge pump and loop filter ([Figure 17](#)). The charge pump generates an error voltage to bring the VCO back into alignment and the loop filter removes any high frequency noise before the error voltage enters the VCO. This new VCO signal enters the clock tree to drive the chip's circuitry.

F_{out} represents the clock signal that emerges from the output pad (the output signal PLLPAD_OUT is explained in [Table 18](#)). This clock signal is meaningful only when the PLL is configured for external use; otherwise, it remains in high Z state, as shown in the post-simulation waveform.

Most QuickLogic products contain four PLLs, one to be used in each quadrant. The PLL presented in **Figure 17** controls the clock tree in the fourth Quadrant of its FPGA. As previously noted, QuickLogic PLLs compensate for the additional delay created by the clock tree itself by subtracting the clock tree delay through the feedback path.

For more specific information on the Phase Locked Loops, please refer to QuickLogic Application Note 58.

PLL Modes of Operation

QuickLogic PLLs have eight modes of operation, based on the input frequency and desired output frequency—**Table 17** indicates the features of each mode.

Table 17: PLL Mode Frequencies

PLL Model	Output Frequency	Input Frequency Range ^a	Output Frequency Range
PLL_HF ^b	Same as input frequency	66 MHz–150 MHz	66 MHz–150 MHz
PLL_LF	Same as input frequency	25 MHz–133 MHz	25 MHz–133 MHz
PLL_MULT2HF	2 × input frequency	50 MHz–125 MHz	100 MHz–250 MHz
PLL_MULT2LF	2 × input frequency	16 MHz–50 MHz	32 MHz–100 MHz
PLL_DIV2HF	1/2 × input frequency	100 MHz–250 MHz	50 MHz–125 MHz
PLL_DIV2LF	1/2 × input frequency	50 MHz–100 MHz	25 MHz–50 MHz
PLL_MULT4	4 × input frequency	16 MHz–40 MHz	64 MHz–160 MHz
PLL_DIV4	1/4 × input frequency	100 MHz–300 MHz	25 MHz–75 MHz

- a. The input frequency can range from 16 MHz to 250 MHz, while output frequency ranges from 25 MHz to 250 MHz. When you add PLLs to your top-level design, be sure that the PLL mode matches your desired input and output frequencies.
- b. HF stands for high frequency and LF stands for low frequency.

PLL Signals

Table 18 summarizes the key signals in QuickLogic's PLLs.

Table 18: PLL Signals

Signal Name	Description
PLLCLK_IN ^a	Input clock signal
PLL_RESET	Active High Reset If PLL_RESET is asserted, then CLKNET_OUT and PLLPAD_OUT are reset to 0. This signal must be asserted and then released in order for the LOCK_DETECT to work.
ONn_OFFCHIP	PLL output This signal selects whether the PLL will drive the internal clock network or be used off-chip. This is a static signal, not a dynamic signal. Tied to GND = outgoing signal drives internal gates. Tied to VCC = outgoing signal used off-chip.
CLKNET_OUT	Out to internal gates This signal bypasses the PLL logic before driving the internal gates. Note that this signal cannot be used in the same quadrant where the PLL signal is used (PLLCLK_OUT).
PLLCLK_OUT	Out from PLL to internal gates This signal can drive the internal gates after going through the PLL. For this to work, ONn_OFFCHIP must be tied to GND.
PLLPAD_OUT	Out to off-chip This outgoing signal is used off-chip. For this to work, ONn_OFFCHIP signal must be tied to VCC.
LOCK_DETECT	Active High Lock detection signal NOTE: For simulation purposes, this signal gets asserted after 10 clock cycles. However, it can take a maximum of 200 clock cycles to sync with the input clock upon release of the RESET signal.

a. Because PLLCLK_IN and PLL_RESET signals have INPAD, and PLLPAD_OUT has OUTPAD, you do not have to add additional pads to your design

Table 19: DC Input and Output Levels^a

	INREF		V _{IL}		V _{IH}		V _{OL}	V _{OH}	I _{OL}	I _{OH}
	V _{MIN}	V _{MAX}	V _{MIN}	V _{MAX}	V _{MIN}	V _{MAX}	V _{MAX}	V _{MIN}	mA	mA
LVTTTL	n/a	n/a	-0.3	0.8	2.2	V _{CCIO} + 0.3	0.4	2.4	2.0	-2.0
LVC MOS2	n/a	n/a	-0.3	0.7	1.7	V _{CCIO} + 0.3	0.7	1.7	2.0	-2.0
LVC MOS18	n/a	n/a	-0.3	0.63	1.2	V _{CCIO} + 0.3	0.7	1.7	2.0	-2.0
GTL+	0.88	1.12	-0.3	INREF - 0.2	INREF + 0.2	V _{CCIO} + 0.3	0.6	n/a	40	n/a
PCI	n/a	n/a	-0.3	0.3 x V _{CCIO}	0.5 x V _{CCIO}	V _{CCIO} + 0.5	0.1 x V _{CCIO}	0.9 x V _{CCIO}	1.5	-0.5
SSTL2	1.15	1.35	-0.3	INREF - 0.18	INREF + 0.18	V _{CCIO} + 0.3	0.74	1.76	7.6	-7.6
SSTL3	1.3	1.7	-0.3	INREF - 0.2	INREF + 0.2	V _{CCIO} + 0.3	1.10	1.90	8	-8

- a. The data provided in **Table 19** are JEDEC and PCI Specifications. QuickLogic devices either meet or exceed these requirements. See preceding **Table 1** through **Table 14** and **Figure 1** through **Figure 17** for data specific to QuickLogic I/Os.

NOTE: All CLK and IOCTRL pins are clamped to the V_{ded} rail. Therefore, these pins can be driven up to $V_{ded} + 0.3$ V.

Package Thermal Characteristics

Thermal Resistance Equations:

$$\theta_{JC} = (T_J - T_C) / P$$

$$\theta_{JA} = (T_J - T_A) / P$$

$$P_{MAX} = (T_{JMAX} - T_{AMAX}) / \theta_{JA}$$

Parameter Description:

θ_{JC} : Junction-to-case thermal resistance

θ_{JA} : Junction-to-ambient thermal resistance

T_J : Junction temperature

T_A : Ambient temperature

P: Power dissipated by the device while operating

P_{MAX} : The maximum power dissipation for the device

T_{JMAX} : Maximum junction temperature

T_{AMAX} : Maximum ambient temperature

NOTE: Maximum junction temperature (T_{JMAX}) is 150° C. To calculate the maximum power dissipation for a device package look up θ_{JA} from **Table 20**, pick an appropriate T_{AMAX} and use:

$$P_{MAX} = (150^\circ \text{ C} - T_{AMAX}) / \theta_{JA}$$

Table 20: Package Thermal Characteristics

Pin Count	Package Description	θ_{JA} (° C/W) @ various flow rates (m/sec)				θ_{JC} (° C/W)
		0	0.5	1	2	
484	PBGA	28.0	26.0	25.0	23.0	9.0
280	LF-PBGA	18.5	17.0	15.5	14.0	7.0
208	PQFP	26.0	24.5	23.0	22.0	11.0

Kv and Kt Graphs

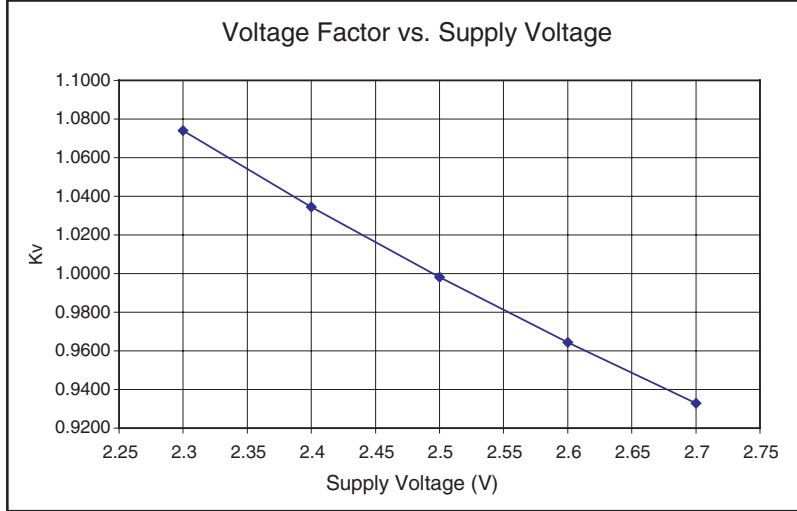

Figure 18: Voltage Factor vs. Supply Voltage

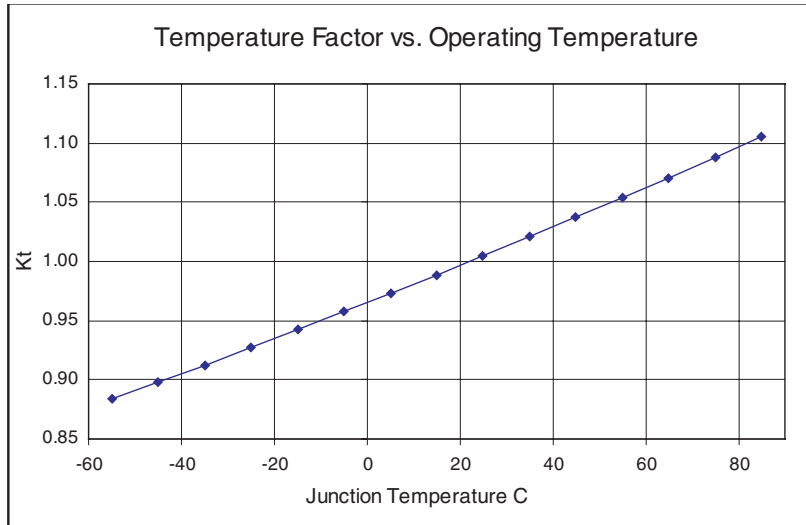

Figure 19: Temperature Factor vs. Operating Temperature

Power vs. Operating Frequency

The basic power equation which best models power consumption is given below:

$$P_{\text{TOTAL}} = 0.350 + f[0.0031 \eta_{\text{LC}} + 0.0948 \eta_{\text{CKBF}} + 0.01 \eta_{\text{CLBF}} + 0.0263 \eta_{\text{CKLD}} + 0.543 \eta_{\text{RAM}} + 0.20 \eta_{\text{PLL}} + 0.0035 \eta_{\text{INP}} + 0.0257 \eta_{\text{OUTP}}] \text{ (mW)}$$

Where

- η_{LC} is the total number of logic cells in the design
- η_{CKBF} = # of clock buffers
- η_{CLBF} = # of column clock buffers
- η_{CKLD} = # of loads connected to the column clock buffers
- η_{RAM} = # of RAM blocks
- η_{PLL} = # of PLLs
- η_{INP} is the number of input pins
- η_{OUTP} is the number of output pins

NOTE: To learn more about power consumption, please refer to Application Note #60.

Power-up Sequencing

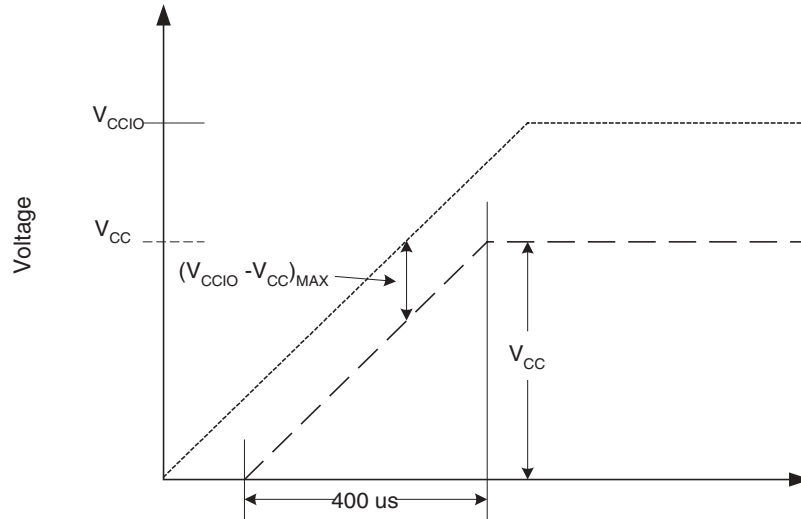

Figure 20: Power-up Requirements

The following requirements must be met when powering up a device (refer to **Figure 20**):

- When ramping up the power supplies keep $(V_{CCIO} - V_{CC})_{MAX} \leq 500$ mV. Deviation from this recommendation can cause permanent damage to the device.
- V_{CCIO} must lead V_{CC} when ramping the device.
- The power supply must be greater than or equal to $400 \mu s$ to reach V_{CC} . Ramping to V_{CC}/V_{CCIO} before reaching $400 \mu s$ can cause the device to behave improperly.

Joint Test Access Group (JTAG)

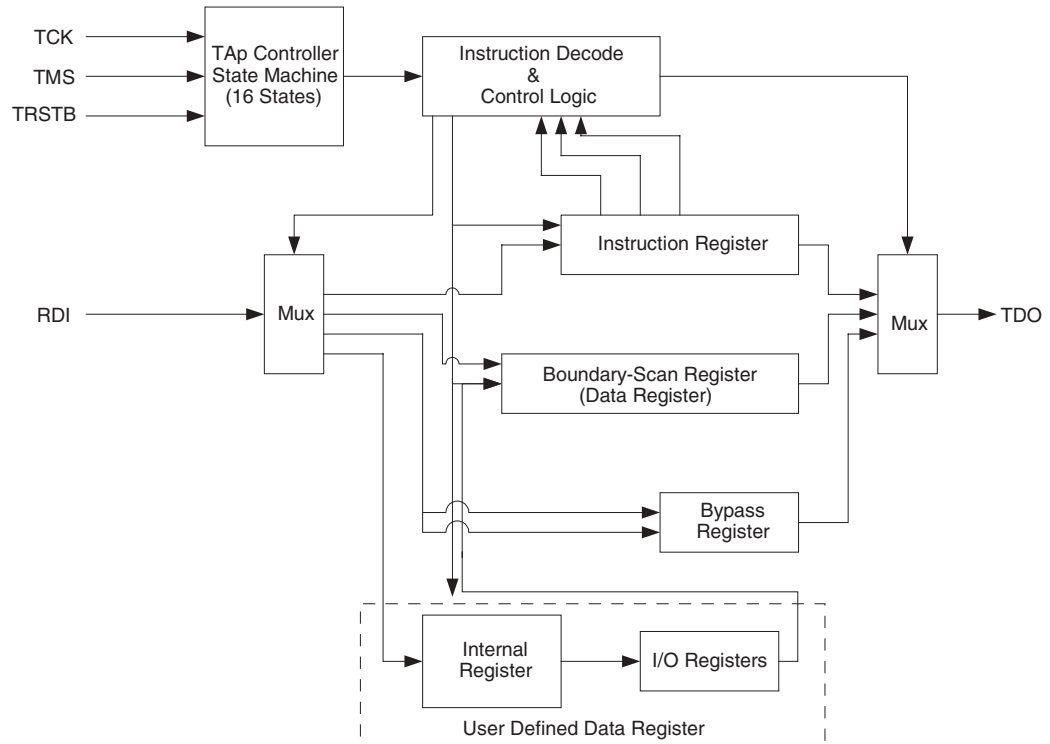

Figure 21: JTAG Block Diagram

Microprocessors and Application Specific Integrated Circuits (ASICs) pose many design challenges, one problem being the accessibility of test points. The Joint Test Access Group (JTAG) formed in response to this challenge, resulting in IEEE standard 1149.1, the Standard Test Access Port and Boundary Scan Architecture.

The JTAG boundary scan test methodology allows complete observation and control of the boundary pins of a JTAG-compatible device through JTAG software. A Test Access Port (TAP) controller works in concert with the Instruction Register (IR), which allow users to run three required tests along with several user-defined tests.

JTAG tests allow users to reduce system debug time, reuse test platforms and tools, and reuse subsystem tests for fuller verification of higher level system elements.

The 1149.1 standard requires the following three tests:

- **Extest Instruction.** The Extest instruction performs a PCB interconnect test. This test places a device into an external boundary test mode, selecting the boundary scan register to be connected between the TAP's Test Data In (TDI) and Test Data Out (TDO) pins. Boundary scan cells are preloaded with test patterns (via the Sample/Preload Instruction), and input boundary cells capture the input data for analysis.
- **Sample/Preload Instruction.** This instruction allows a device to remain in its functional mode, while selecting the boundary scan register to be connected between the TDI and TDO pins. For this test, the boundary scan register can be accessed via a data scan operation, allowing users to sample the functional data entering and leaving the device.
- **Bypass Instruction.** The Bypass instruction allows data to skip a device's boundary scan entirely, so the data passes through the bypass register. The Bypass instruction allows users to test a device without passing through other devices. The bypass register is connected between the TDI and TDO pins, allowing serial data to be transferred through a device without affecting the operation of the device.

Pin Descriptions

Table 21: JTAG Pin Descriptions

Pin	Function	Description
TDI/RSI	Test Data In for JTAG/RAM init. Serial Data In	Hold HIGH during normal operation. Connects to serial PROM data in for RAM initialization. Connect to V _{CC} if unused
TRSTB/RRO	Active low Reset for JTAG/RAM init. reset out	Hold LOW during normal operation. Connects to serial PROM reset for RAM initialization. Connect to GND if unused
TMS	Test Mode Select for JTAG	Hold HIGH during normal operation. Connect to V _{CC} if not used for JTAG
TCK	Test Clock for JTAG	Hold HIGH or LOW during normal operation. Connect to V _{CC} or ground if not used for JTAG
TDO/RCO	Test data out for JTAG/RAM init. clock out	Connect to serial PROM clock for RAM initialization. Must be left unconnected if not used for JTAG or RAM initialization

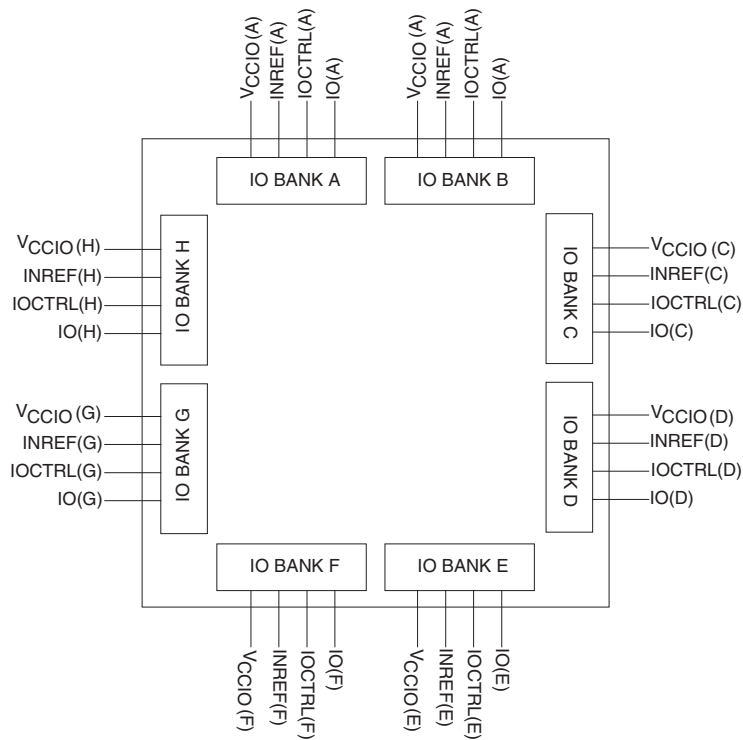

Figure 22: I/O Banks with Relevant Pins

Table 22: Dedicated Pin Descriptions

Pin	Function	Description
GCLK	Global clock network driver	Low skew global clock. This pin provides access to a dedicated, distributed network capable of driving the CLOCK, SET, RESET, F1, and A2 inputs to the Logic Cell, READ, and WRITE CLOCKS, Read and Write Enables of the Embedded RAM Blocks, CLOCK of the ECUs, and Output Enables of the I/Os.
I/O(A)	Input/Output pin	The I/O pin is a bi-directional pin, configurable to either an input-only, output-only, or bi-directional pin. The A inside the parenthesis means that the I/O is located in Bank A. If an I/O is not used, SpDE (QuickWorks Tool) provides the option of tying that pin to GND, V _{CC} , or TriState during programming.
V _{CC}	Power supply pin	Connect to 2.5 V supply
V _{CCIO} (A)	Input voltage tolerance pin	This pin provides the flexibility to interface the device with either a 3.3 V, 2.5 V, or 1.8 V device. The A inside the parenthesis means that V _{CCIO} is located in BANK A. Every I/O pin in Bank A will be tolerant of V _{CCIO} input signals and will output V _{CCIO} level signals. This pin must be connected to either 3.3 V, 2.5 V, or 1.8 V.
GND	Ground pin	Connect to ground
PLLIN	PLL clock input	Clock input for PLL
DEDCLK	Dedicated clock pin	Low skew global clock. This pin provides access to a dedicated, distributed clock network capable of driving the CLOCK inputs of all sequential elements of the device (e.g. RAM, Flip Flops).
GNDPLL	Ground pin for PLL	Connect to GND
INREF(A)	Differential reference voltage	The INREF is the reference voltage pin for GTL+, SSTL2, and STTL3 standards. Follow the recommendations provided in Table 19 for the appropriate standard. The A inside the parenthesis means that INREF is located in BANK A. This pin should be tied to GND if not needed.
PLLOUT	PLL output pin	Dedicated PLL output pin; otherwise, may be left unconnected
IOCTRL(A)	Highdrive input	This pin provides fast RESET, SET, CLOCK, and ENABLE access to the I/O cell flip-flops, providing fast clock-to-out and fast I/O response times. This pin can also double as a high-drive pin to the internal logic cells. The A inside the parenthesis means that IOCTRL is located in Bank A. There is an internal pulldown resistor to Ground on this pin. This pin should be tied to Ground if it is not used. For backwards compatibility with Eclipse, it can be tied to V _{cc} or Ground. If tied to V _{cc} , it will draw no more than 20 μA per IOCTRL pin due to the pulldown resistor.

(Sheet 1 of 2)

Table 22: Dedicated Pin Descriptions

Pin	Function	Description
Vpump	Charge Pump Disable	This pin disables the internal charge pump for lower static power operation. To disable the charge pump, connect Vpump to 3.3 V. If the Disable Charge Pump feature is not used, connect Vpump to Ground. For backwards compatibility with Eclipse and EclipsePlus devices, connect Vpump to Ground.
Vded	Voltage tolerance for clocks, JTAG, and IOCTRL/Voltage Drive for PLLOUT and JTAG pins	This pin specifies the input voltage tolerance for CLK, JTAG, and IOCTRL dedicated input pins, as well as the output voltage drive for PLLOUT and JTAG pins. If the PLLs are used, Vded must be the same as V _{CC} PLL. For backwards compatibility with Eclipse and EclipsePlus devices, connect Vded to 2.5 V.
VccPLL	Power Supply pin for PLL	Connect to 2.5 V supply or 3.3 V supply. For backwards compatibility with Eclipse and EclipsePlus devices, connect to 2.5 V.

(Sheet 2 of 2)

Recommended Unused Pin Terminations for the Eclipse-E Devices

All unused, general purpose I/O pins can be tied to V_{CC} , GND, or HIZ (high impedance) internally using the Configuration Editor. This option is given in the bottom-right corner of the placement window. To use the Placement Editor, choose **Constraint > Fix Placement** in the Option pull-down menu of SpDE.

The rest of the pins should be terminated at the board level in the manner presented in **Table 23**.

Table 23: Recommended Unused Pin Terminations

Signal Name	Recommended Termination
PLLOUT<x> ^a	Unused PLL output pins must be connected to either V_{CC} or GND so that their associated input buffer never floats. Utilized PLL output pins that route the PLL clock outside of the chip should not be tied to either V_{CC} or GND.
IOCTRL<y> ^b	Any unused pins of this type must be connected to either V_{CC} or GND.
CLK/PLLIN<x>	Any unused clock pins should be connected to V_{CC} or GND.
PLLRST<x>	If a PLL module is not used, then the associated PLLRST<x> must be connected to V_{CC} , under normal operation use it as needed.
INREF<y>	If an I/O bank does not require the use of INREF signal the pin should be connected to GND.

a. x represents a number.

b. y represents an alphabetical character.

208 PQFP Pinout Diagram



208 PQFP Pinout Table

Table 24: 208 PQFP Pinout Table

PQFP	Function	PQFP	Function	PQFP	Function	PQFP	Function	PQFP	Function
1	PLLST(3)	43	IO(B)	85	IO(D)	127	CLK(5),PLLIN(3)	169	IOCTRL(G)
2	V _{CCPLL} (3)	44	V _{CCIO} (B)	86	V _{CC}	128	CLK(6)	170	INREF(G)
3	GND	45	IO(B)	87	IO(D)	129	V _{dcd}	171	IOCTRL(G)
4	GND	46	V _{CC}	88	IO(D)	130	CLK(7)	172	IO(G)
5	IO(A)	47	IO(B)	89	V _{CC}	131	V _{CC}	173	IO(G)
6	IO(A)	48	IO(B)	90	IO(D)	132	CLK(8)	174	IO(V)
7	IO(A)	49	GND	91	IO(D)	133	TMS	175	V _{CC}
8	V _{CCIO} (A)	50	TDO	92	IOCTRL(D)	134	IO(F)	176	IO(G)
9	IO(A)	51	PLLOUT(1)	93	INREF(D)	135	IO(F)	177	V _{CCIO} (G)
10	IO(A)	52	GNDPLL(2)	94	IOCTRL(D)	136	IO(F)	178	GND
11	IOCTRL(A)	53	GND	95	IO(D)	137	GND	179	IO(G)
12	V _{CC}	54	V _{CCPLL} (2)	96	IO(D)	138	V _{CCIO} (F)	180	IO(G)
13	INREF(A)	55	PLLST(2)	97	IO(D)	139	IO(F)	181	IO(G)
14	IOCTRL(A)	56	V _{CC}	98	V _{CCIO} (D)	140	IO(F)	182	V _{CC}
15	IO(A)	57	IO(C)	99	IO(D)	141	IO(F)	183	TCK
16	IO(A)	58	GND	100	IO(D)	142	IO(F)	184	V _{CC}
17	IO(A)	59	IO(C)	101	V _{pump}	143	IO(F)	185	IO(H)
18	IO(A)	60	V _{CCIO} (C)	102	PLLOUT(0)	144	IOCTRL(F)	186	IO(H)
19	V _{CCIO} (A)	61	IO(C)	103	GND	145	INREF(F)	187	IO(H)
20	IO(A)	62	IO(C)	104	GNDPLL(1)	146	V _{CC}	188	GND
21	GND	63	IO(C)	105	PLLST(1)	147	IOCTRL(F)	189	V _{CCIO} (H)
22	IO(A)	64	IO(C)	106	V _{CCPLL} (1)	148	IO(F)	190	IO(H)
23	TDI	65	IO(C)	107	IO(E)	149	IO(F)	191	IO(H)
24	CLK(0)	66	IO(C)	108	GND	150	V _{CCIO} (F)	192	IOCTRL(H)
25	CLK(1)	67	IOCTRL(C)	109	IO(E)	151	IO(F)	193	IO(H)
26	V _{CC}	68	INREF(C)	110	IO(E)	152	IO(F)	194	INREF(H)
27	CLK(2),PLLIN(2)	69	IOCTRL(C)	111	V _{CCIO} (E)	153	GND	195	V _{CC}
28	CLK(3),PLLIN(1)	70	IO(C)	112	IO(E)	154	IO(F)	196	IOCTRL(H)
29	V _{dcd}	71	IO(C)	113	V _{CC}	155	PLLOUT(3)	197	IO(H)
30	CLK(4), DEDCLK,PLLIN(0)	72	V _{CCIO} (C)	114	IO(E)	156	GNDPLL(0)	198	IO(H)
31	IO(B)	73	IO(C)	115	IO(E)	157	GND	199	IO(H)
32	IO(B)	74	IO(C)	116	IO(E)	158	V _{CCPLL} (0)	200	IO(H)
33	GND	75	GND	117	IOCTRL(E)	159	PLLST(0)	201	IO(H)
34	V _{CCIO} (B)	76	V _{CC}	118	INREF(E)	160	GND	202	IO(H)
35	IO(B)	77	IO(C)	119	IOCTRL(E)	161	IO(G)	203	V _{CCIO} (H)
36	IO(B)	78	TRSTB	120	IO(E)	162	V _{CCIO} (G)	204	GND
37	IO(B)	79	V _{CC}	121	IO(E)	163	IO(G)	205	IO(H)
38	IO(B)	80	IO(D)	122	V _{CCIO} (E)	164	IO(G)	206	PLLOUT(2)
39	IOCTRL(B)	81	IO(D)	123	GND	165	V _{CC}	207	GND
40	INREF(B)	82	IO(D)	124	IO(E)	166	IO(G)	208	GNDPLL(3)
41	IOCTRL(B)	83	GND	125	IO(E)	167	IO(G)		
42	IO(B)	84	V _{CCIO} (D)	126	IO(E)	168	IO(G)		

280 PBGA Pinout Diagram

Top



Bottom

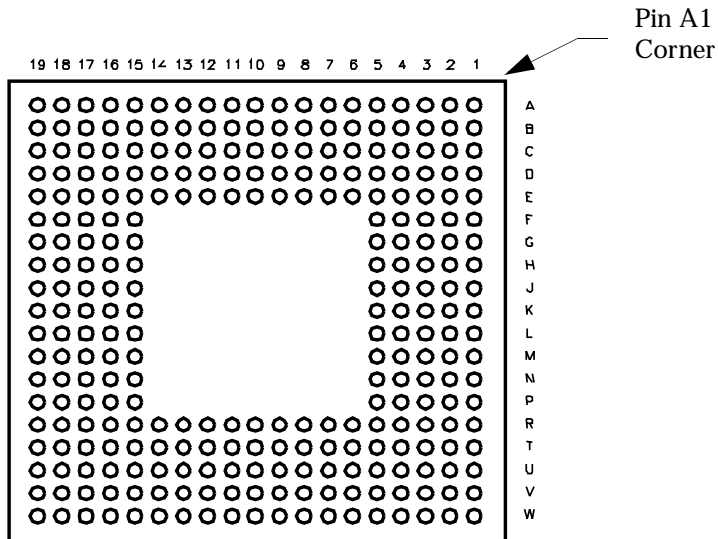

280 PBGA Pinout Table

Table 25: 280 PBGA Pinout Table

PBGA	Function	PBGA	Function	PBGA	Function	PBGA	Function	PBGA	Function	PBGA	Function
A1	PLLOUT<3>	C10	CLK<5>/PLLIN<3>	E19	IOCTRL<D>	K16	I/O<C>	R4	I/O<H>	U13	I/O
A2	GNDPLL<0>	C11	V _{CCIO<E>}	F1	INREF<G>	K17	I/O<D>	R5	GND	U14	IOCTRL
A3	I/O<F>	C12	I/O<E>	F2	IOCTRL<G>	K18	I/O<C>	R6	GND	U15	V _{CCIO}
A4	I/O<F>	C13	I/O<E>	F3	I/O<G>	K19	TRSTB	R7	V _{CC}	U16	I/O
A5	I/O<F>	C14	I/O<E>	F4	I/O<G>	L1	I/O<H>	R8	V _{CC}	U17	TDO
A6	IOCTRL<F>	C15	V _{CCIO<E>}	F5	GND	L2	I/O<H>	R9	GND	U18	PLL<2>
A7	I/O<F>	C16	I/O<E>	F15	V _{CC}	L3	V _{CCIO<H>}	R10	GND	U19	I/O
A8	I/O<F>	C17	I/O<E>	F16	IOCTRL<D>	L4	I/O<H>	R11	V _{CC}	V1	PLLOUT<2>
A9	I/O<F>	C18	I/O<E>	F17	I/O<D>	L5	V _{CC}	R12	V _{CC}	V2	GNDPLL<3>
A10	CLK<7>	C19	I/O<E>	F18	I/O<D>	L15	GND	R13	V _{CC}	V3	GND
A11	I/O<E>	D1	I/O<G>	F19	I/O<D>	L16	I/O<C>	R14	V _{dcd}	V4	I/O<A>
A12	I/O<E>	D2	I/O<G>	G1	I/O<G>	L17	V _{CCIO<C>}	R15	GND	V5	I/O<A>
A13	I/O<E>	D3	I/O<F>	G2	I/O<G>	L18	I/O<C>	R16	I/O<C>	V6	IOCTRL<A>
A14	IOCTRL<E>	D4	I/O<F>	G3	IOCTRL<G>	L19	I/O<C>	R17	V _{CCIO<C>}	V7	I/O<A>
A15	I/O<E>	D5	I/O<F>	G4	I/O<G>	M1	I/O<H>	R18	I/O<C>	V8	I/O<A>
A16	I/O<E>	D6	I/O<F>	G5	V _{CC}	M2	I/O<H>	R19	I/O<C>	V9	I/O<A>
A17	I/O<E>	D7	I/O<F>	G15	V _{CC}	M3	I/O<H>	T1	I/O<H>	V10	CLK<1>
A18	PLL<1>	D8	I/O<F>	G16	I/O<D>	M4	I/O<H>	T2	I/O<H>	V11	CLK<4>/DEDCLK/PLLIN<0>
A19	GND	D9	CLK<8>	G17	I/O<D>	M5	V _{CC}	T3	I/O<A>	V12	I/O
B1	PLL<0>	D10	I/O<E>	G18	I/O<D>	M15	V _{CC}	T4	I/O<A>	V13	I/O
B2	GND	D11	I/O<E>	G19	I/O<D>	M16	INREF<C>	T5	I/O<A>	V14	INREF
B3	I/O<F>	D12	I/O<E>	H1	I/O<G>	M17	I/O<C>	T6	IOCTRL<A>	V15	I/O
B4	I/O<F>	D13	INREF<E>	H2	I/O<G>	M18	I/O<C>	T7	I/O<A>	V16	I/O
B5	I/O<F>	D14	I/O<E>	H3	I/O<G>	M19	I/O<C>	T8	I/O<A>	V17	I/O
B6	INREF<F>	D15	I/O<E>	H4	I/O<G>	N1	IOCTRL<H>	T9	I/O<A>	V18	GNDPLL<2>
B7	I/O<F>	D16	I/O<D>	H5	V _{CC}	N2	I/O<H>	T10	I/O<A>	V19	GND
B8	I/O<F>	D17	I/O<D>	H15	V _{CC}	N3	I/O<H>	T11	CLK<3>/PLLIN<1>	W1	GND
B9	TMS	D18	I/O<D>	H16	V _{CC}	N4	I/O<H>	T12	I/O	W2	PLL<3>
B10	CLK<6>	D19	I/O<D>	H17	I/O<D>	N5	V _{CC}	T13	I/O	W3	I/O<A>
B11	I/O<E>	E1	I/O<G>	H18	I/O<D>	N15	V _{CC}	T14	I/O	W4	I/O<A>
B12	I/O<E>	E2	I/O<G>	H19	I/O<D>	N16	I/O<C>	T15	I/O	W5	I/O<A>
B13	IOCTRL<E>	E3	V _{CCIO<G>}	J1	I/O<G>	N17	I/O<C>	T16	I/O	W6	I/O<A>
B14	I/O<E>	E4	I/O<F>	J2	I/O<G>	N18	IOCTRL<C>	T17	V _{CCPLL<2>}	W7	I/O<A>
B15	I/O<E>	E5	GND	J3	V _{CCIO<G>}	N19	IOCTRL<C>	T18	I/O	W8	I/O<A>
B16	I/O<E>	E6	V _{CC}	J4	I/O<G>	P1	I/O<H>	T19	I/O	W9	TDI
B17	V _{CCPLL<1>}	E7	V _{CC}	J5	GND	P2	I/O<H>	U1	I/O<A>	W10	CLK<2>/PLLIN<2>
B18	GNDPLL<1>	E8	V _{dcd}	J15	V _{CC}	P3	IOCTRL<H>	U2	I/O<A>	W11	I/O
B19	PLLOUT<0>	E9	V _{CC}	J16	I/O<C>	P4	INREF<H>	U3	V _{CCPLL<3>}	W12	I/O
C1	I/O<F>	E10	GND	J17	V _{CCIO<D>}	P5	V _{CC}	U4	I/O<A>	W13	I/O
C2	V _{CCPLL<0>}	E11	GND	J18	I/O<D>	P15	GND	U5	V _{CCIO<A>}	W14	IOCTRL
C3	I/O<F>	E12	V _{CC}	J19	I/O<D>	P16	I/O<C>	U6	INREF<A>	W15	I/O
C4	I/O<F>	E13	V _{CC}	K1	V _{CC}	P17	I/O<C>	U7	I/O<A>	W16	I/O
C5	V _{CCIO<F>}	E14	GND	K2	TCK	P18	I/O<C>	U8	I/O<A>	W17	I/O
C6	IOCTRL<F>	E15	V _{pump}	K3	I/O<G>	P19	I/O<C>	U9	V _{CCIO<A>}	W18	I/O
C7	I/O<F>	E16	I/O<D>	K4	I/O<G>	R1	I/O<H>	U10	CLK<0>	W19	PLLOUT<1>
C8	I/O<F>	E17	V _{CCIO<D>}	K5	GND	R2	I/O<H>	U11	V _{CCIO}		
C9	V _{CCIO<F>}	E18	INREF<D>	K15	GND	R3	V _{CCIO<H>}	U12	I/O		

484 PBGA Pinout Diagram

Top

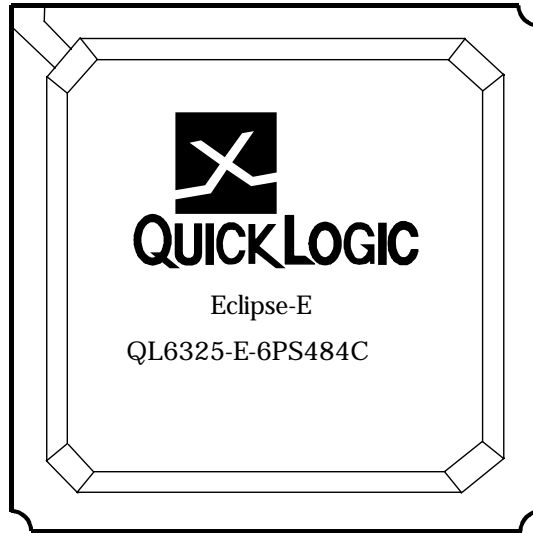

Bottom

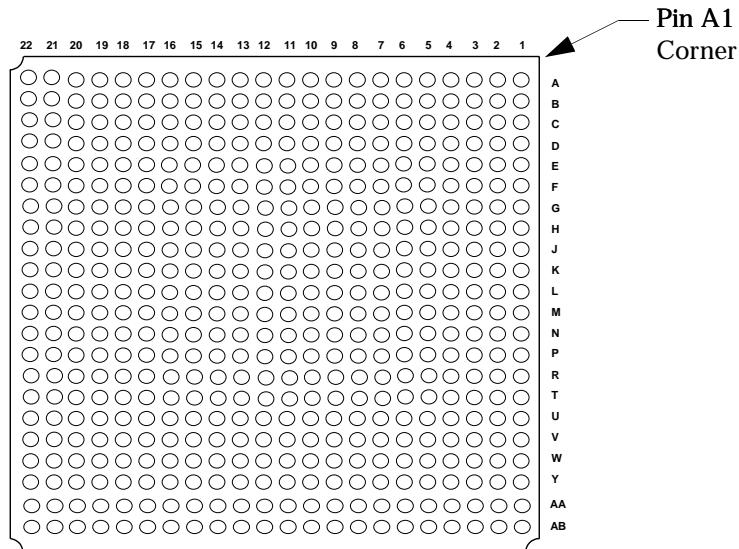

484 PBGA Pinout Table

Table 26: 484 PBGA Pinout Table

PBGA	Function	PBGA	Function	PBGA	Function	PBGA	Function	PBGA	Function	PBGA	Function
A1	I/O<A>	C1	I/O<A>	E1	IOCTRL<A>	G1	I/O<A>	J1	I/O<A>	L1	CLK<4> DEDCLK/PLLIN<0>
A2	PLLST<3>	C2	I/O<A>	E2	I/O<A>	G2	I/O<A>	J2	I/O<A>	L2	CLK<0>
A3	I/O<A>	C3	V _{CC} PLL<3>	E3	I/O<A>	G3	I/O<A>	J3	I/O<A>	L3	CLK<2>/PLLIN<2>
A4	I/O<A>	C4	PLLOUT<2>	E4	I/O<A>	G4	I/O<A>	J4	I/O<A>	L4	I/O<A>
A5	I/O<A>	C5	I/O<A>	E5	I/O<A>	G5	I/O<A>	J5	I/O<A>	L5	I/O<A>
A6	I/O<H>	C6	I/O<H>	E6	I/O<H>	G6	I/O<A>	J6	I/O<A>	L6	I/O<A>
A7	I/O<H>	C7	I/O<H>	E7	N/C	G7	GND	J7	I/O<A>	L7	GND
A8	IOCTRL<H>	C8	I/O<H>	E8	I/O<H>	G8	I/O<H>	J8	V _{CC}	L8	GND
A9	I/O<H>	C9	IOCTRL<H>	E9	I/O<H>	G9	I/O<H>	J9	GND	L9	GND
A10	N/C	C10	I/O<H>	E10	I/O<H>	G10	I/O<H>	J10	V _{CC}	L10	GND
A11	N/C	C11	I/O<H>	E11	V _{CC}	G11	I/O<G>	J11	V _{CC}	L11	GND
A12	TCK	C12	I/O<H>	E12	I/O<G>	G12	GND	J12	GND	L12	GND
A13	I/O<G>	C13	I/O<G>	E13	I/O<G>	G13	I/O<G>	J13	V _{CC}	L13	GND
A14	I/O<G>	C14	I/O<G>	E14	I/O<G>	G14	I/O<G>	J14	GND	L14	V _{CC}
A15	I/O<G>	C15	I/O<G>	E15	IOCTRL<G>	G15	I/O<G>	J15	V _{CC}	L15	V _{CC}
A16	I/O<G>	C16	I/O<G>	E16	I/O<G>	G16	V _{pump}	J16	I/O<F>	L16	CLK<6>
A17	I/O<G>	C17	I/O<G>	E17	INREF<G>	G17	V _{CCIO<F>}	J17	V _{CCIO<F>}	L17	V _{CCIO<F>}
A18	I/O<G>	C18	I/O<G>	E18	I/O<G>	G18	I/O<F>	J18	I/O<F>	L18	I/O<F>
A19	I/O<F>	C19	I/O<F>	E19	I/O<F>	G19	I/O<F>	J19	I/O<F>	L19	CLK<8>
A20	GND	C20	GNDPLL<0>	E20	I/O<F>	G20	I/O<F>	J20	I/O<F>	L20	I/O<F>
A21	PLLOUT<3>	C21	I/O<F>	E21	I/O<F>	G21	INREF<F>	J21	I/O<F>	L21	I/O<F>
A22	I/O<F>	C22	I/O<F>	E22	I/O<F>	G22	I/O<F>	J22	I/O<F>	L22	I/O<F>
B1	I/O<A>	D1	I/O<A>	F1	I/O<A>	H1	I/O<A>	K1	TDI	M1	I/O
B2	GND	D2	I/O<A>	F2	INREF<A>	H2	I/O<A>	K2	I/O<A>	M2	I/O
B3	GNDPLL<3>	D3	I/O<A>	F3	I/O<A>	H3	I/O<A>	K3	I/O<A>	M3	I/O
B4	GND	D4	I/O<A>	F4	I/O<A>	H4	I/O<A>	K4	I/O<A>	M4	CLK<3>/PLLIN<1>
B5	I/O<A>	D5	I/O<A>	F5	I/O<A>	H5	IOCTRL<A>	K5	I/O<A>	M5	I/O
B6	I/O<H>	D6	I/O<H>	F6	V _{CCIO<A>}	H6	V _{CCIO<A>}	K6	V _{CCIO<A>}	M6	V _{CCIO}
B7	I/O<H>	D7	I/O<H>	F7	V _{CCIO<H>}	H7	I/O<H>	K7	I/O<A>	M7	CLK<1>
B8	INREF<H>	D8	I/O<H>	F8	I/O<H>	H8	GND	K8	V _{CC}	M8	V _{CC}
B9	I/O<H>	D9	I/O<H>	F9	V _{CCIO<H>}	H9	V _{CC}	K9	V _{CC}	M9	V _{CC}
B10	I/O<H>	D10	I/O<H>	F10	I/O<H>	H10	V _{CC}	K10	GND	M10	GND
B11	I/O<H>	D11	I/O<H>	F11	V _{CCIO<H>}	H11	V _{ded}	K11	GND	M11	GND
B12	N/C	D12	I/O<G>	F12	V _{CCIO<G>}	H12	GND	K12	GND	M12	GND
B13	N/C	D13	I/O<G>	F13	I/O<G>	H13	V _{CC}	K13	GND	M13	GND
B14	N/C	D14	I/O<G>	F14	V _{CCIO<G>}	H14	V _{CC}	K14	V _{CC}	M14	GND
B15	I/O<G>	D15	IOCTRL<G>	F15	N/C	H15	GND	K15	V _{CC}	M15	GND
B16	I/O<G>	D16	I/O<G>	F16	V _{CCIO<G>}	H16	I/O<F>	K16	I/O<F>	M16	GND
B17	I/O<G>	D17	I/O<G>	F17	N/C	H17	I/O<F>	K17	I/O<F>	M17	I/O<E>
B18	I/O<G>	D18	I/O<F>	F18	I/O<F>	H18	I/O<F>	K18	I/O<F>	M18	I/O<E>
B19	PLLST<0>	D19	V _{CC} PLL<0>	F19	I/O<F>	H19	I/O<F>	K19	I/O<F>	M19	I/O<E>
B20	I/O<F>	D20	I/O<F>	F20	IOCTRL<F>	H20	I/O<F>	K20	I/O<F>	M20	CLK<7>
B21	I/O<F>	D21	I/O<F>	F21	I/O<F>	H21	I/O<F>	K21	I/O<F>	M21	CLK<5>/PLLIN<3>
B22	I/O<F>	D22	I/O<F>	F22	IOCTRL<F>	H22	I/O<F>	K22	I/O<F>	M22	TMS

(Sheet 1 of 2)

Table 26: 484 PBGA Pinout Table (Continued)

PBGA	Function	PBGA	Function	PBGA	Function	PBGA	Function	PBGA	Function	PBGA	Function
N1	I/O	P16	I/O<E>	T9	N/C	V2	I/O	W17	I/O<D>	AA10	I/O<C>
N2	I/O	P17	I/O<E>	T10	TRSTB	V3	I/O	W18	I/O<E>	AA11	I/O<C>
N3	I/O	P18	I/O<E>	T11	GND	V4	I/O	W19	I/O<E>	AA12	I/O<D>
N4	I/O	P19	I/O<E>	T12	N/C	V5	I/O	W20	I/O<E>	AA13	I/O<D>
N5	I/O	P20	I/O<E>	T13	I/O<D>	V6	I/O<C>	W21	I/O<E>	AA14	I/O<D>
N6	I/O	P21	I/O<E>	T14	N/C	V7	I/O<C>	W22	I/O<E>	AA15	I/O<D>
N7	I/O	P22	I/O<E>	T15	I/O<D>	V8	I/O<C>	Y1	I/O	AA16	I/O<D>
N8	V _{CC}	R1	I/O	T16	GND	V9	N/C	Y2	I/O	AA17	I/O<D>
N9	V _{CC}	R2	INREF	T17	I/O<E>	V10	I/O<C>	Y3	V _{CCPLL<2>}	AA18	I/O<D>
N10	GND	R3	I/O	T18	I/O<E>	V11	I/O<C>	Y4	I/O<C>	AA19	I/O<E>
N11	GND	R4	I/O	T19	I/O<E>	V12	V _{CC}	Y5	I/O<C>	AA20	GNDPLL<1>
N12	GND	R5	I/O	T20	I/O<E>	V13	N/C	Y6	I/O<C>	AA21	I/O<E>
N13	GND	R6	I/O	T21	IOCTRL<E>	V14	I/O<D>	Y7	I/O<C>	AA22	I/O<E>
N14	V _{CC}	R7	I/O	T22	I/O<E>	V15	I/O<D>	Y8	IOCTRL<C>	AB1	I/O
N15	V _{CC}	R8	GND	U1	IOCTRL	V16	INREF<D>	Y9	I/O<C>	AB2	GNDPLL<2>
N16	I/O<E>	R9	V _{CC}	U2	I/O	V17	I/O<D>	Y10	I/O<C>	AB3	PLLST<2>
N17	V _{CCIO<E>}	R10	V _{CC}	U3	IOCTRL	V18	I/O<E>	Y11	I/O<D>	AB4	I/O
N18	I/O<E>	R11	GND	U4	I/O	V19	I/O<E>	Y12	I/O<D>	AB5	I/O
N19	I/O<E>	R12	V _{dcd}	U5	I/O	V20	I/O<E>	Y13	I/O<D>	AB6	I/O<C>
N20	I/O<E>	R13	V _{CC}	U6	I/O<C>	V21	I/O<E>	Y14	I/O<D>	AB7	I/O<C>
N21	I/O<E>	R14	V _{CC}	U7	V _{CCIO<C>}	V22	I/O<E>	Y15	IOCTRL<D>	AB8	IOCTRL<C>
N22	I/O<E>	R15	GND	U8	N/C	W1	I/O	Y16	I/O<D>	AB9	I/O<C>
P1	I/O	R16	I/O<D>	U9	V _{CCIO<C>}	W2	I/O	Y17	I/O<D>	AB10	I/O<C>
P2	I/O	R17	V _{CCIO<E>}	U10	I/O<C>	W3	I/O	Y18	I/O<E>	AB11	I/O<C>
P3	I/O	R18	I/O<E>	U11	V _{CCIO<C>}	W4	I/O	Y19	PLLOUT<0>	AB12	I/O<D>
P4	I/O	R19	I/O<E>	U12	V _{CCIO<D>}	W5	I/O	Y20	PLLST<1>	AB13	I/O<D>
P5	I/O	R20	I/O<E>	U13	I/O<D>	W6	I/O<C>	Y21	I/O<E>	AB14	I/O<D>
P6	V _{CCIO}	R21	I/O<E>	U14	V _{CCIO<D>}	W7	N/C	Y22	I/O<E>	AB15	I/O<D>
P7	I/O	R22	I/O<E>	U15	N/C	W8	I/O<C>	AA1	TDO	AB16	IOCTRL<D>
P8	V _{CC}	T1	I/O	U16	V _{CCIO<D>}	W9	I/O<C>	AA2	PLLOUT<1>	AB17	I/O<D>
P9	GND	T2	I/O	U17	V _{CCIO<E>}	W10	I/O<C>	AA3	GND	AB18	I/O<D>
P10	V _{CC}	T3	I/O	U18	I/O<E>	W11	I/O<C>	AA4	I/O	AB19	I/O<E>
P11	GND	T4	I/O	U19	I/O<E>	W12	I/O<D>	AA5	I/O<C>	AB20	GND
P12	V _{CC}	T5	I/O	U20	IOCTRL<E>	W13	I/O<D>	AA6	I/O<C>	AB21	V _{CCPLL<1>}
P13	V _{CC}	T6	V _{CCIO}	U21	I/O<E>	W14	I/O<D>	AA7	I/O<C>	AB22	I/O<E>
P14	GND	T7	GND	U22	INREF<E>	W15	I/O<D>	AA8	INREF<C>		
P15	V _{CC}	T8	I/O<C>	V1	I/O	W16	N/C	AA9	I/O<C>		

(Sheet 2 of 2)

Ordering Information

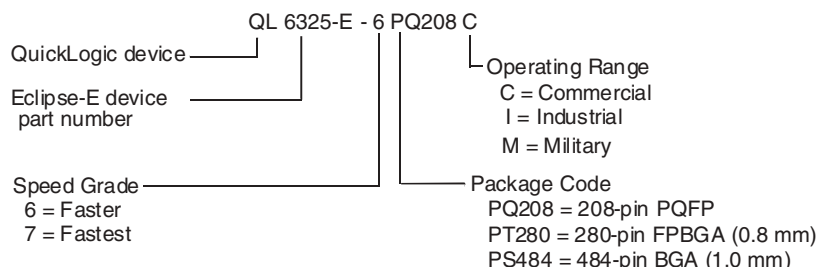

Figure 23: Ordering Information

Contact Information

Telephone: 408 990 4000 (US)
 416 497 8884 (Canada)
 44 1932 57 9011 (Europe)
 49 89 930 86 170 (Germany)
 852 8106 9091 (Asia)
 81 45 470 5525 (Japan)

E-mail: info@quicklogic.com

Support: support@quicklogic.com

Web site: <http://www.quicklogic.com/>

Revision History

Table 27: Revision History

Revision	Date	Comments
A	December 2002	Brian Faith, Andreea Rotaru

Copyright and Trademark Information

Copyright © 2002 QuickLogic Corporation.
All Rights Reserved.

The information contained in this document and the accompanying software programs is protected by copyright. All rights are reserved by QuickLogic Corporation. QuickLogic Corporation reserves the right to modify this document without any obligation to notify any person or entity of such revision. Copying, duplicating, selling, or otherwise distributing any part of this product without the prior written consent of an authorized representative of QuickLogic is prohibited.

QuickLogic and the QuickLogic logo, pASIC, ViaLink, DeskFab, and QuickWorks are registered trademarks of QuickLogic Corporation; Eclipse, QuickFC, QuickDSP, QuickDR, QuickSD, QuickTools, QuickCore, QuickPro, SpDE, WebASIC, and WebESP are trademarks of QuickLogic Corporation.