

QL3012 pASIC 3 FPGA Data Sheet



- • • • • **12,000 Usable PLD Gate pASIC 3 FPGA Combining High Performance and High Density**

Device Highlights

High Performance & High Density

- 12,000 Usable PLD Gates with 118 I/Os
- 300 MHz 16-bit Counters, 400 MHz Datapaths
- 0.35 μ m four-layer metal non-volatile CMOS process for smallest die sizes

Easy to Use / Fast Development Cycles

- 100% routable with 100% utilization and complete pin-out stability
- Variable-grain logic cells provide high performance and 100% utilization
- Comprehensive design tools include high quality Verilog/VHDL synthesis

Advanced I/O Capabilities

- Interfaces with both 3.3 V and 5.0 V devices
- PCI compliant with 3.3 V and 5.0 V buses for -1/-2/-3/-4 speed grades
- Full JTAG boundary scan
- I/O Cells with individually controlled Registered Input Path and Output Enables

Total of 118 I/O Pins

- 110 bidirectional input/output pins, PCI-compliant for 5.0 V and 3.3 V buses for -1/-2/-3/-4 speed grades
- Four High Drive input-only pins
- Four High Drive input-only/distributed network pins

Four Low-Skew Distributed Networks

- Two array clock/control networks available to the logic cell flip-flop clock, set and reset inputs — each driven by an input-only pin
- Two global clock/control networks available to the logic cell; F1, clock set, reset inputs and the input, I/O register clock, reset, and enable inputs as well as the output enable control — each driven by an input-only or I/O pin, or any logic cell output or I/O cell feedback

High Performance

- Input + logic cell + output total delays under 6 ns
- Data path speeds over 400 MHz
- Counter speeds over 300 MHz

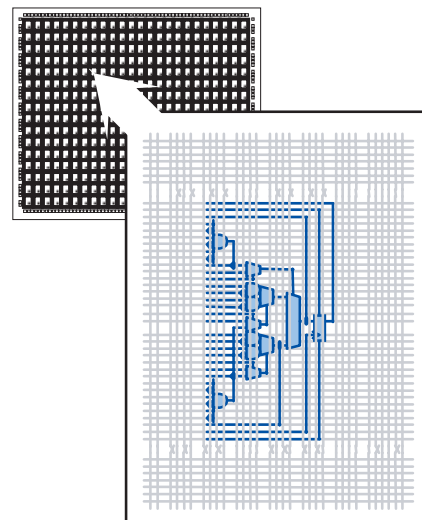

Figure 1: 320 pASIC 3 Logic Cells

Architecture Overview

The QL3012 is a 12,000 usable PLD gate member of the pASIC 3 family of FPGAs. pASIC 3 FPGAs are fabricated on a 0.35 μm four-layer metal process using QuickLogic[®]'s patented ViaLink[®] technology to provide a unique combination of high performance, high density, low cost, and extreme ease-of-use.

The QL3012 contains 320 logic cells. With a maximum of 118 I/Os, the QL3012 is available in 84-pin PLCC, 100-pin TQFP, and 144-pin TQFP packages.

Software support for the complete pASIC 3 family, including the QL3012, is available through three basic packages. The turnkey QuickWorks[®] package provides the most complete FPGA software solution from design entry to logic synthesis, to place and route, to simulation. The QuickTools[™] for Workstations package provides a solution for designers who use Cadence[®], Exemplar[™], Mentor[®], Synopsys[®], Synplicity[®], Viewlogic[™], Aldec[™], or other third-party tools for design entry, synthesis, or simulation.

Electrical Specifications

AC Characteristics at $V_{CC} = 3.3\text{ V}$, $T_A = 25^\circ\text{C}$ ($K = 1.00$)

To calculate delays, multiply the appropriate K factor from **Table 7** by the numbers provided in **Table 1** through **Table 5**.

Table 1: Logic Cells

Symbol	Parameter	Propagation Delays (ns) Fanout ^a				
		1	2	3	4	8
t_{PD}	Combinatorial Delay ^b	1.4	1.7	1.9	2.2	3.2
t_{SU}	Setup Time ^b	1.7	1.7	1.7	1.7	1.7
t_H	Hold Time	0.0	0.0	0.0	0.0	0.0
t_{CLK}	Clock to Q Delay	0.7	1.0	1.2	1.5	2.5
t_{CWHI}	Clock High Time	1.2	1.2	1.2	1.2	1.2
t_{CWLO}	Clock Low Time	1.2	1.2	1.2	1.2	1.2
t_{SET}	Set Delay	1.0	1.3	1.5	1.8	2.8
t_{RESET}	Reset Delay	0.8	1.1	1.3	1.6	2.6
t_{SW}	Set Width	1.9	1.9	1.9	1.9	1.9
t_{RW}	Reset Width	1.8	1.8	1.8	1.8	1.8

- a. Stated timing for worst case Propagation Delay over process variation at $V_{CC} = 3.3\text{ V}$ and $T_A = 25^\circ\text{C}$. Multiply by the appropriate Delay Factor, K, for speed grade, voltage, and temperature settings as specified in **Table 7**.
- b. These limits are derived from a representative selection of the slowest paths through the pASIC 3 logic cell including typical net delays. Worst case delay values for specific paths should be determined from timing analysis of your particular design.

Table 2: Input-Only/Clock Cells

Symbol	Parameter	Propagation Delays (ns) Fanout ^a						
		1	2	3	4	8	12	24
t_{IN}	High Drive Input Delay	1.5	1.6	1.8	1.9	2.4	2.9	4.4
t_{INI}	High Drive Input, Inverting Delay	1.6	1.7	1.9	2.0	2.5	3.0	4.5
t_{ISU}	Input Register Set-Up Time	3.1	3.1	3.1	3.1	3.1	3.1	3.1
t_{IH}	Input Register Hold Time	0.0	0.0	0.0	0.0	0.0	0.0	0.0
t_{ICLK}	Input Register Clock To Q	0.7	0.8	1.0	1.1	1.6	2.1	3.6
t_{IRST}	Input Register Reset Delay	0.6	0.7	0.9	1.0	1.5	2.0	3.5
t_{IESU}	Input Register clock Enable Set-Up Time	2.3	2.3	2.3	2.3	2.3	2.3	2.3
t_{IEH}	Input Register Clock Enable Hold Time	0.0	0.0	0.0	0.0	0.0	0.0	0.0

- a. Stated timing for worst case Propagation Delay over process variation at $V_{CC} = 3.3\text{ V}$ and $T_A = 25^\circ\text{C}$. Multiply by the appropriate Delay Factor, K, for speed grade, voltage, and temperature settings as specified in **Table 7**.

Table 3: Clock Cells

Symbol	Parameter	Propagation Delays (ns) Loads per Half Column ^a						
		1	2	3	4	8	10	11
t _{ACK}	Array Clock Delay	1.2	1.2	1.3	1.3	1.5	1.6	1.7
t _{GCKP}	Global Clock Pin Delay	0.7	0.7	0.7	0.7	0.7	0.7	0.7
t _{GCKB}	Global Clock Buffer Delay	0.8	0.8	0.9	0.9	1.1	1.2	1.3

- a. The array distributed networks consist of 40 half columns and the global distributed networks consist of 44 half columns, each driven by an independent buffer. The number of half columns used does not affect clock buffer delay. The array clock has up to eight loads per half column. The global clock has up to 11 loads per half column.

Table 4: Input-Only I/O Cells

Symbol	Parameter	Propagation Delays (ns) Fanout ^a					
		1	2	3	4	8	10
t _{I/O}	Input Delay (bidirectional pad)	1.3	1.6	1.8	2.1	3.1	3.6
t _{ISU}	Input Register Set-Up Time	3.1	3.1	3.1	3.1	3.1	3.1
t _{IH}	Input Register Hold Time	0.0	0.0	0.0	0.0	0.0	0.0
t _{IOCLK}	Input Register Clock To Q	0.7	1.0	1.2	1.5	2.5	3.0
t _{IORST}	Input Register Reset Delay	0.6	0.9	1.1	1.4	2.4	2.9
t _{IESU}	Input Register clock Enable Set-Up Time	2.3	2.3	2.3	2.3	2.3	2.3
t _{IEH}	Input Register Clock Enable Hold Time	0.0	0.0	0.0	0.0	0.0	0.0

- a. Stated timing for worst case Propagation Delay over process variation at V_{CC} = 3.3 V and TA = 25°C. Multiply by the appropriate Delay Factor, K, for speed grade, voltage, and temperature settings as specified in [Table 7](#).

Table 5: Output-Only I/O Cells

Symbol	Parameter	Propagation Delays (ns) Output Load Capacitance (pF)				
		30	50	75	100	150
t_{OUTLH}	Output Delay Low to High	2.1	2.5	3.1	3.6	4.7
t_{OUTHL}	Output Delay High to Low	2.2	2.6	3.2	3.7	4.8
t_{PZH}	Output Delay Tri-state to High	1.2	1.7	2.2	2.8	3.9
t_{PZL}	Output Delay Tri-state to Low	1.6	2.0	2.6	3.1	4.2
t_{PHZ}	Output Delay High to Tri-State ^a	2.0	-	-	-	-
t_{PLZ}	Output Delay Low to Tri-State	1.2	-	-	-	-

a. The loads presented in **Figure 2** are used for t_{PXZ} :

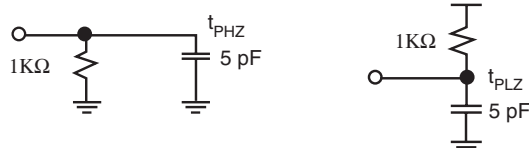

Figure 2: Loads used for t_{PXZ}

DC Characteristics

The DC specifications are provided in **Table 6** through **Table 8**.

Table 6: Absolute Maximum Ratings

Parameter	Value	Parameter	Value
V _{CC} Voltage	-0.5 V to 4.6 V	DC Input Current	±20 mA
V _{CCIO} Voltage	-0.5 V to 7.0 V	ESD Pad Protection	±2000 V
Input Voltage	-0.5 V to V _{CCIO} +0.5 V	Storage Temperature	-65°C to +150°C
Latch-up Immunity	±200 mA	Lead Temperature	300°C

Table 7: Operating Range

Symbol	Parameter	Military		Industrial		Commercial		Unit	
		Min	Max	Min	Max	Min	Max		
V _{CC}	Supply Voltage	3.0	3.6	3.0	3.6	3.0	3.6	V	
V _{CCIO}	I/O Input Tolerance Voltage	3.0	5.5	3.0	5.5	3.0	5.25	V	
TA	Ambient Temperature	-55	-	-40	85	0	70	°C	
TC	Case Temperature	-	125	-	-	-	-	°C	
K	Delay Factor	-0 Speed Grade	-	-	0.43	1.90	0.46	1.85	n/a
		-1 Speed Grade	0.42	1.64	0.43	1.54	0.46	1.50	n/a
		-2 Speed Grade	0.42	1.37	0.43	1.28	0.46	1.25	n/a
		-3 Speed Grade			0.43	0.90	0.46	0.88	n/a
		-4 Speed Grade			0.43	0.82	0.46	0.80	n/a

Table 8: DC Characteristics

Symbol	Parameter	Conditions	Min	Max	Units
V_{IH}	Input HIGH Voltage		$0.5 V_{CC}$	$V_{CCIO}+0.5$	V
V_{IL}	Input LOW Voltage		-0.5	$0.3 V_{CC}$	V
V_{OH}	Output HIGH Voltage	$I_{OH} = -12 \text{ mA}$	2.4		V
		$I_{OH} = -500 \mu\text{A}$	$0.9 V_{CC}$		V
V_{OL}	Output LOW Voltage	$I_{OL} = 16 \text{ mA}^a$		0.45	V
		$I_{OL} = 1.5 \text{ mA}$		$0.1 V_{CC}$	V
I_I	I or I/O Input Leakage Current	$V_I = V_{CCIO}$ or GND	-10	10	μA
I_{OZ}	3-State Output Leakage Current	$V_I = V_{CCIO}$ or GND	-10	10	μA
C_I	Input Capacitance ^b			10	pF
I_{OS}	Output Short Circuit Current ^c	$V_O = \text{GND}$	-15	-180	mA
		$V_O = V_{CC}$	40	210	mA
I_{CC}	D.C. Supply Current ^d	$V_I, V_{IO} = V_{CCIO}$ or GND	0.50 (typ)	2	mA
I_{CCIO}	D.C. Supply Current on V_{CCIO}		0	100	μA

- a. Applies only to -1/-2/-3/-4 commercial grade devices. These speed grades are also PCI-compliant. All other devices have 8 mA IOL specifications.
- b. Capacitance is sample tested only. Clock pins are 12 pF maximum.
- c. Only one output at a time. Duration should not exceed 30 seconds.
- d. For -1/-2/-3/-4 commercial grade devices only. Maximum I_{CC} is 3 mA for -0 commercial grade and all industrial grade devices, and 5 mA for all military grade devices. For AC conditions, contact QuickLogic customer applications group (see [Contact Information](#)).

Kv and Kt Graphs

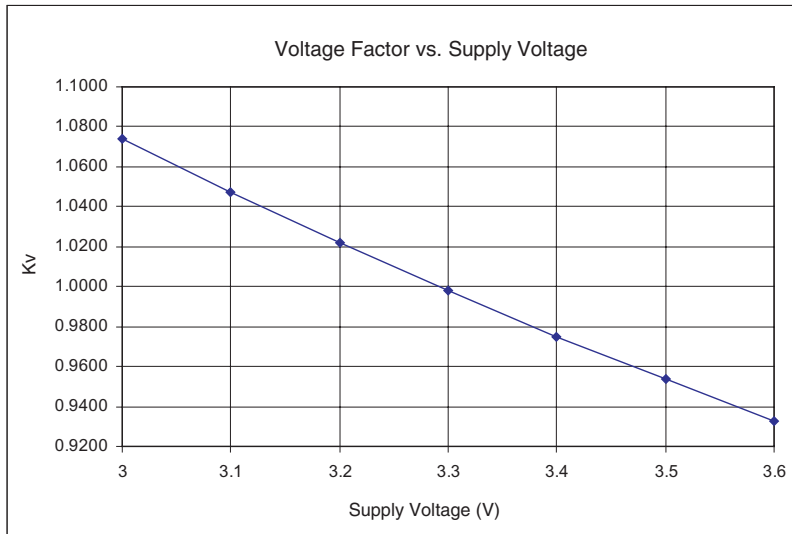

Figure 3: Voltage Factor vs. Supply Voltage

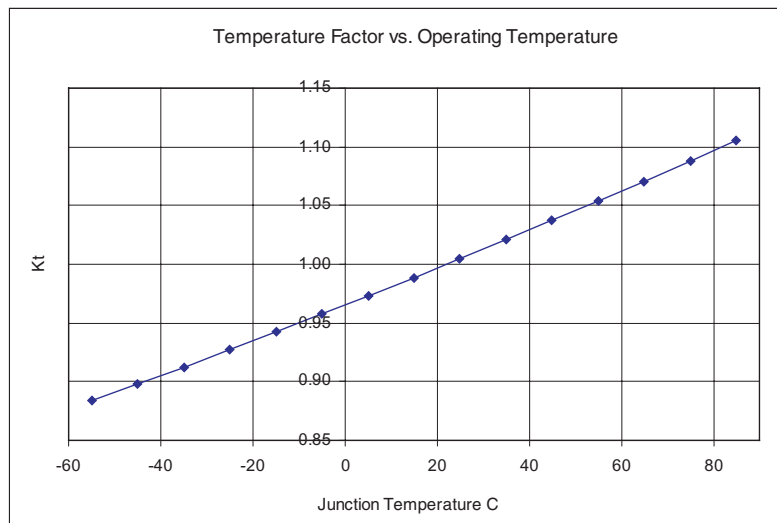

Figure 4: Temperature Factor vs. Operating Temperature

Power-up Sequencing

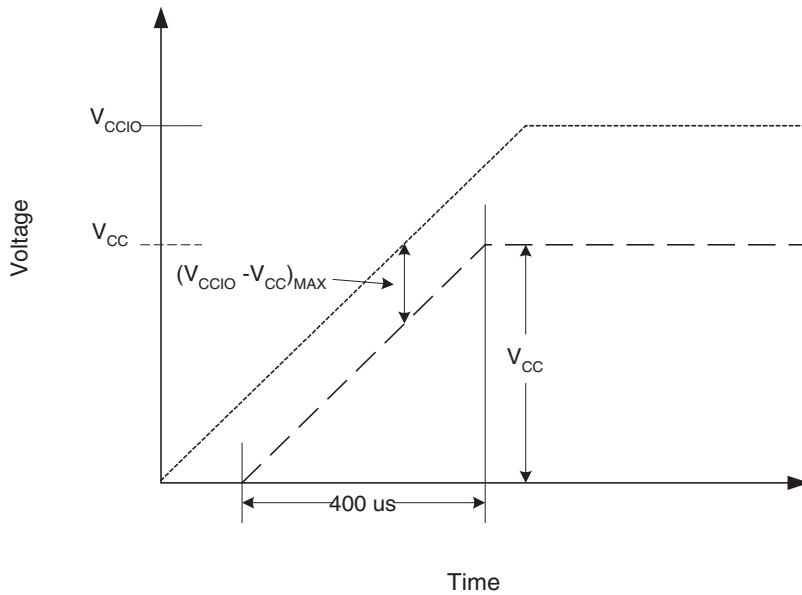

Figure 5: Power-up Requirements

The following requirements must be met when powering up the device: (Refer to **Figure 5**)

- When ramping up the power supplies keep $(V_{CCIO} - V_{CC})_{MAX} \leq 500$ mV. Deviation from this recommendation can cause permanent damage to the device.
- V_{CCIO} must lead V_{CC} when ramping the device.
- The power supply must take greater than or equal to 400 μ s to reach V_{CC} . Ramping to V_{CC}/V_{CCIO} earlier than 400 μ s can cause the device to behave improperly.

An internal diode is present in-between V_{CC} and V_{CCIO} , as shown in **Figure 6**.

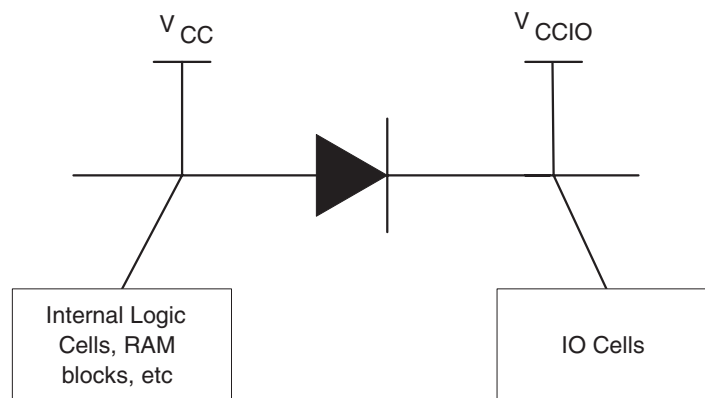

Figure 6: Internal Diode Between V_{CC} and V_{CCIO}

JTAG

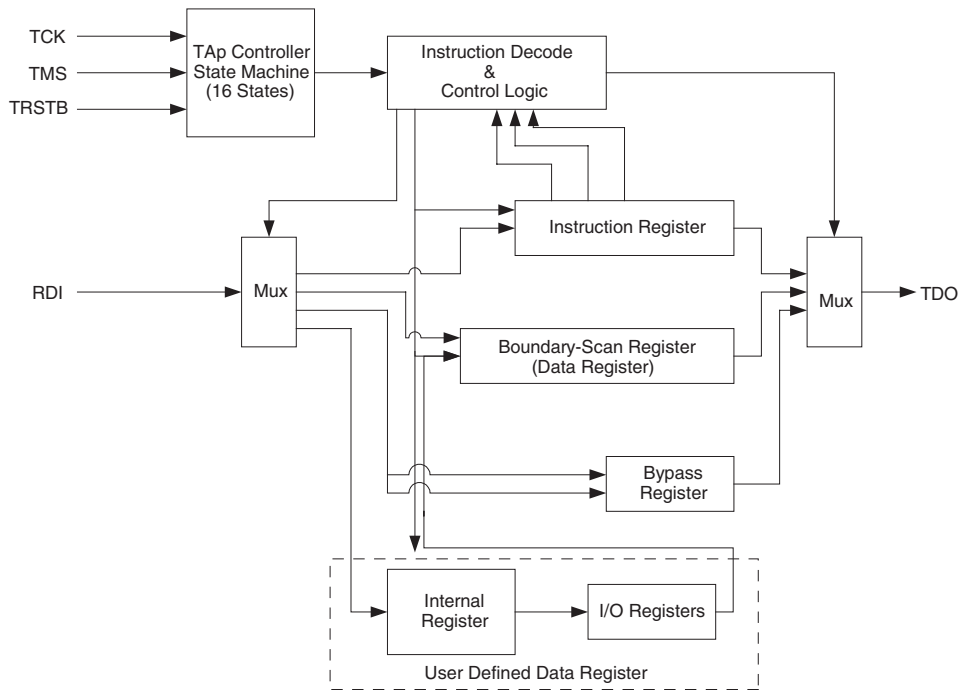

Figure 7: JTAG Block Diagram

Microprocessors and Application Specific Integrated Circuits (ASICs) pose many design challenges, not the least of which concerns the accessibility of test points. The Joint Test Access Group (JTAG) formed in response to this challenge, resulting in IEEE standard 1149.1, the Standard Test Access Port and Boundary Scan Architecture.

The JTAG boundary scan test methodology allows complete observation and control of the boundary pins of a JTAG-compatible device through JTAG software. A Test Access Port (TAP) controller works in concert with the Instruction Register (IR); these allow users to run three required tests, along with several user-defined tests.

JTAG tests allow users to reduce system debug time, reuse test platforms and tools, and reuse subsystem tests for fuller verification of higher level system elements.

The 1149.1 standard requires the following three tests:

- **Exttest Instruction.** The Exttest instruction performs a PCB interconnect test. This test places a device into an external boundary test mode, selecting the boundary scan register to be connected between the TAP's Test Data In (TDI) and Test Data Out (TDO) pins. Boundary scan cells are preloaded with test patterns (via the Sample/Preload Instruction), and input boundary cells capture the input data for analysis.
- **Sample/Preload Instruction.** This instruction allows a device to remain in its functional mode, while selecting the boundary scan register to be connected between the TDI and TDO pins. For this test, the boundary scan register can be accessed via a data scan operation, allowing users to sample the functional data entering and leaving the device.
- **Bypass Instruction.** The Bypass instruction allows data to skip a device's boundary scan entirely, so the data passes through the bypass register. The Bypass instruction allows users to test a device without passing through other devices. The bypass register is connected between the TDI and TDO pins, allowing serial data to be transferred through a device without affecting the operation of the device.

Pin Descriptions

Table 9: Pin Descriptions

Pin	Function	Description
TDI	Test Data In for JTAG	Hold HIGH during normal operation. Connect to V _{CC} if not used for JTAG.
TRSTB	Active low Reset for JTAG	Hold LOW during normal operation. Connect to ground if not used for JTAG.
TMS	Test Mode Select for JTAG	Hold HIGH during normal operation. Connect to V _{CC} if not used for JTAG.
TCK	Test Clock for JTAG	Hold HIGH or LOW during normal operation. Connect to V _{CC} or ground if not used for JTAG.
TDO	Test data out for JTAG	Output that must be left unconnected if not used for JTAG.
STM	Special Test Mode	Must be grounded during normal operation.
I/ACLK	High-drive input and/or array network driver	Can be configured as either or both.
I/GCLK	High-drive input and/or global network driver	Can be configured as either or both.
I	High-drive input	Use for input signals with high fanout.
I/O	Input/Output pin	Can be configured as an input and/or output.
V _{CC}	Power supply pin	Connect to 3.3 V supply.
V _{CCIO}	Input voltage tolerance pin	Connect to 5.0 V supply if 5 V input tolerance is required, otherwise connect to 3.3 V supply.
GND	Ground pin	Connect to ground.

Ordering Information

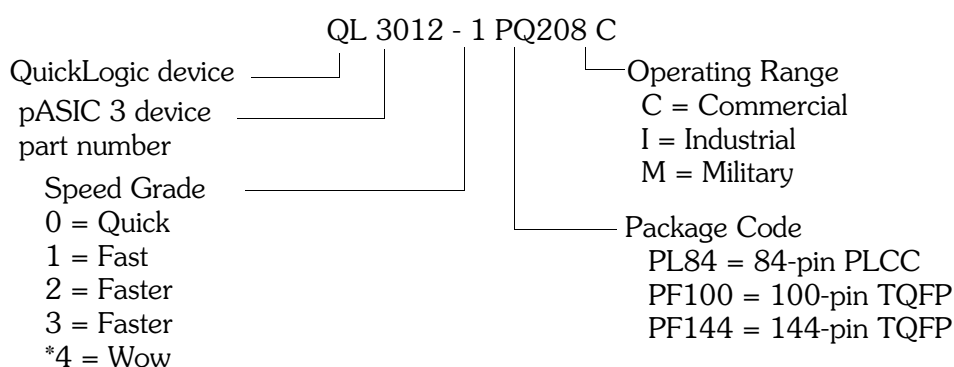

* Contact QuickLogic regarding availability (see [Contact Information](#))

84 PLCC Pinout Diagram

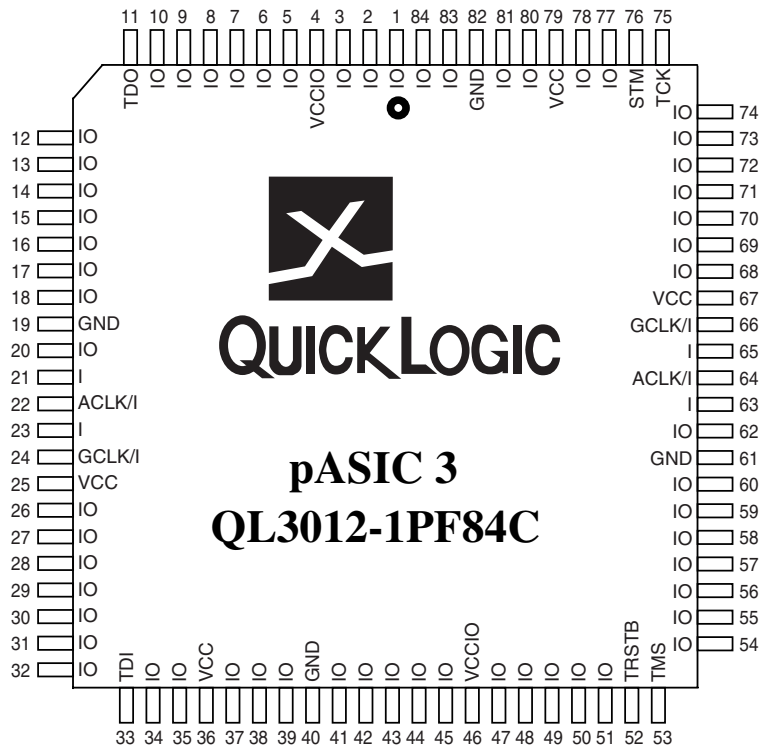

Figure 8: Top View of 84 Pin PLCC

84 PLCC Pinout Diagram

Table 10: 84 PLCC Pinout Diagram

84 PLCC	Function	84 PLCC	Function	84 PLCC	Function	84 PLCC	Function
1	I/O	22	ACLK/I	43	I/O	64	ACLK/I
2	I/O	23	I	44	I/O	65	I
3	I/O	24	GCLK/I	45	I/O	66	GCLK/I
4	V _{CCIO}	25	V _{CC}	46	V _{CCIO}	67	V _{CC}
5	I/O	26	I/O	47	I/O	68	I/O
6	I/O	27	I/O	48	I/O	69	I/O
7	I/O	28	I/O	49	I/O	70	I/O
8	I/O	29	I/O	50	I/O	71	I/O
9	I/O	30	I/O	51	I/O	72	I/O
10	I/O	31	I/O	52	TRSTB	73	I/O
11	TDO	32	I/O	53	TMS	74	I/O
12	I/O	33	TDI	54	I/O	75	TCK
13	I/O	34	I/O	55	I/O	76	STM
14	I/O	35	I/O	56	I/O	77	I/O
15	I/O	36	V _{CC}	57	I/O	78	I/O
16	I/O	37	I/O	58	I/O	79	V _{CC}
17	I/O	38	I/O	59	I/O	80	I/O
18	I/O	39	I/O	60	I/O	81	I/O
19	GND	40	GND	61	GND	82	GND
20	I/O	41	I/O	62	I/O	83	I/O
21	I	42	I/O	63	I	84	I/O

100 TQFP Pinout Diagram

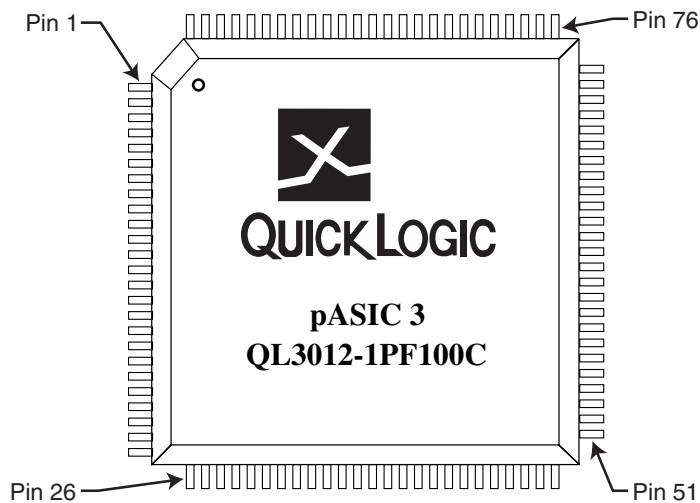

Figure 9: Top View of 100 Pin TQFP

144 TQFP Pinout Diagram

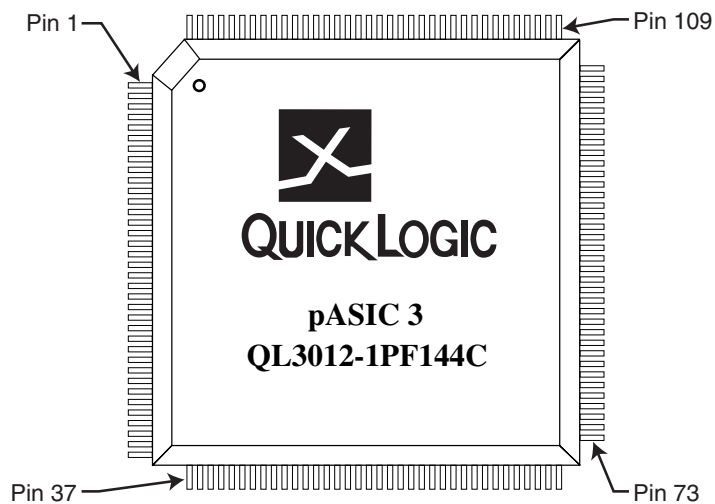

Figure 10: Top View of 144 Pin TQFP

100 & 144 TQFP Pinout Table

Table 11: 100 & 144 TQFP Pinout Table

144 TQFP	100 TQFP	Function	144 TQFP	100 TQFP	Function	144 TQFP	100 TQFP	Function	144 TQFP	100 TQFP	Function
1	2	I/O	38	26	TDI	75	53	I/O	111	78	I/O
2	3	I/O	39	27	I/O	76	54	I/O	112	79	I/O
3	NC	I/O	40	28	I/O	77	55	I/O	113	80	I/O
4	4	I/O	41	29	I/O	78	NC	I/O	114	NC	V _{CC}
5	NC	I/O	42	NC	V _{CC}	79	NC	V _{CC}	115	81	I/O
6	5	I/O	43	30	I/O	80	NC	I/O	116	82	I/O
7	NC	V _{CC}	44	31	I/O	81	56	I/O	117	83	I/O
8	6	I/O	45	NC	I/O	82	NC	I/O	118	NC	I/O
9	NC	I/O	46	32	I/O	83	57	I/O	119	84	I/O
10	7	I/O	47	33	I/O	84	NC	I/O	120	NC	I/O
11	NC	I/O	48	NC	I/O	85	58	I/O	121	NC	I/O
12	NC	I/O	49	34	I/O	86	NC	I/O	122	85	GND
13	8	I/O	50	35	GND	87	59	GND	123	NC	I/O
14	NC	I/O	51	36	I/O	88	60	I/O	124	86	I/O
15	9	GND	52	NC	I/O	89	61	I	125	87	I/O
16	10	I/O	53	37	I/O	90	62	ACLK / I	126	88	GND
17	11	I	54	38	GND	91	63	V _{CC}	127	89	I/O
18	12	ACLK / I	55	39	I/O	92	64	I	128	90	I/O
19	13	V _{CC}	56	40	I/O	93	65	GCLK / I	129	91	I/O
20	14	I	57	41	I/O	94	66	V _{CC}	130	92	V _{CCIO}
21	15	GCLK / I	58	42	V _{CCIO}	95	67	I/O	131	NC	I/O
22	16	V _{CC}	59	NC	I/O	96	NC	I/O	132	93	I/O
23	17	I/O	60	43	I/O	NC	68	I/O	133	NC	I/O
24	18	I/O	61	44	I/O	97	NC	I/O	134	94	I/O
25	NC	I/O	62	45	I/O	98	69	I/O	135	NC	I/O
26	19	I/O	63	NC	I/O	99	NC	I/O	136	NC	I/O
27	NC	I/O	64	NC	I/O	100	70	I/O	NC	95	I/O
28	20	I/O	65	46	I/O	101	71	I/O	137	NC	I/O
29	21	I/O	66	NC	GND	102	NC	GND	138	NC	GND
30	NC	GND	67	NC	I/O	103	NC	I/O	139	96	I/O
31	NC	I/O	68	NC	I/O	104	72	I/O	140	97	I/O
32	22	I/O	69	47	I/O	105	NC	I/O	141	98	I/O
33	23	I/O	70	48	I/O	106	73	I/O	142	99	I/O
34	NC	I/O	71	49	TRSTB	107	74	I/O	143	100	TDO
35	NC	I/O	72	50	TMS	108	75	I/O	144	1	I/O
36	24	I/O	73	51	I/O	109	76	TCK			
37	25	I/O	74	52	I/O	110	77	STM			

Contact Information

Telephone: 408 990 4000 (US)
 416 497 8884 (Canada)
 44 1932 57 9011 (Europe)
 49 89 930 86 170 (Germany)
 852 8106 9091 (Asia)
 81 45 470 5525 (Japan)

E-mail: info@quicklogic.com
 Support: support@quicklogic.com
 Web site: <http://www.quicklogic.com/>

Revision History

Table 12: Revision History

Revision	Date	Comments
A	not avail.	First release.
B	not avail.	
C	not avail.	
D	May 2001	Update of AC/DC Specs and reformat
E	June 2002	Added Kfactor, Power-up, JTAG and mechanical drawing information. Reformatted.

Copyright Information

Copyright © 2002 QuickLogic Corporation.

All Rights Reserved.

The information contained in this product brief, and the accompanying software programs are protected by copyright. All rights are reserved by QuickLogic Corporation. QuickLogic Corporation reserves the right to make periodic modifications of this product without obligation to notify any person or entity of such revision. Copying, duplicating, selling, or otherwise distributing any part of this product without the prior written consent of an authorized representative of QuickLogic is prohibited.

QuickLogic, QuickWorks, pASIC, and ViaLink are registered trademarks of QuickLogic Corporation.

Verilog is a registered trademark of Cadence Design Systems, Inc.

All trademarks and registered trademarks are the property of their respective owners.