

# QL7160 EclipsePlus Data Sheet



••••• Combining Performance, Density and Embedded RAM

## Device Highlights

### Flexible Programmable Logic

- .25  $\mu\text{m}$  five layer metal CMOS Process
- 2.5 V  $V_{CC}$ , 2.5 V/3.3 V Drive Capable I/O
- 3,072 Logic Cells
- 488,064 Max System Gates
- 444 I/O Pins

### Embedded Dual Port SRAM

- Thirty-two 2,304-bit Dual Port High Performance SRAM Blocks
- 73,728 RAM Bits
- RAM/ROM/FIFO Wizard for Automatic Configuration
- Configurable and Cascadable

### Programmable I/O

- High performance Enhanced I/O (EIO)—less than 3 ns  $T_{CO}$
- Programmable Slew Rate Control
- Programmable I/O Standards:
  - LVTTTL, LVCMOS, PCI, GTL+, SSTL2, and SSTL3
  - Eight Independent I/O Banks
  - Three Register Configurations: Input, Output, and Output Enable

### Advanced Clock Network

- Nine Global Clock Networks:
  - One Dedicated
  - Eight Programmable
- 20 Quad-Net Networks—five per Quadrant
- 16 I/O Controls—two per I/O Bank
- Four phase locked loops

### Embedded Computational Units

ECUs provide integrated Multiply, Add, and Accumulate Functions.

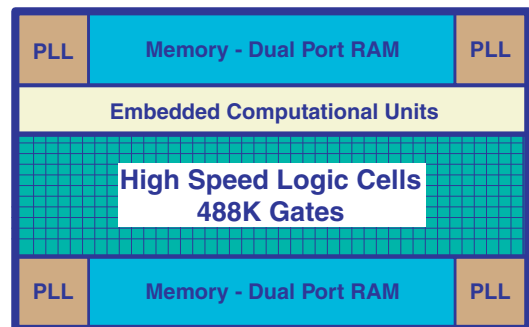

Figure 1: EclipsePlus Block Diagram

## Electrical Specifications

### AC Characteristics\*

\*(at  $V_{CC} = 2.5\text{ V}$ ,  $T_A = 25^\circ\text{ C}$ , Typical Corner, Speed Grade = -7 ( $K = 0.74$ ))

The AC Specifications are provided from **Table 1** to **Table 10**. Logic Cell diagrams and waveforms are provided from **Figure 2** to **Figure 15**.

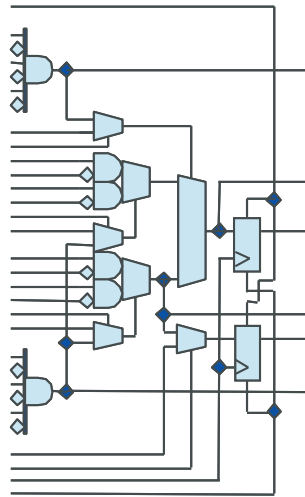

Figure 2: EclipsePlus Logic Cell

Table 1: Logic Cells

Symbol Logic Cells	Parameter	Value	
		Min	Max
$t_{PD}$	Combinatorial Delay of the longest path: time taken by the combinatorial circuit to output	-	0.257 ns
$t_{SU}$	Setup time: time the synchronous input of the flip-flop must be stable before the active clock edge	0.22 ns	-
$t_{HL}$	Hold time: time the synchronous input of the flip-flop must be stable after the active clock edge	0 ns	-
$t_{CO}$	Clock-to-out delay: the amount of time taken by the flip-flop to output after the active clock edge.	-	0.255 ns
$t_{CWHI}$	Clock High Time: required minimum time the clock stays high	0.46 ns	-
$t_{CWLO}$	Clock Low Time: required minimum time that the clock stays low	0.46 ns	-
$t_{SET}$	Set Delay: time between when the flip-flop is "set" (high) and when the output is consequently "set" (high)	-	0.18 ns

Table 1: Logic Cells (Continued)

Symbol Logic Cells	Parameter	Value	
		Min	Max
$t_{\text{RESET}}$	Reset Delay: time between when the flip-flop is "reset" (low) and when the output is consequently "reset" (low)	-	0.09 ns
$t_{\text{SW}}$	Set Width: time that the SET signal remains high/low	0.3 ns	-
$t_{\text{RW}}$	Reset Width: time that the RESET signal remains high/low	0.3 ns	-

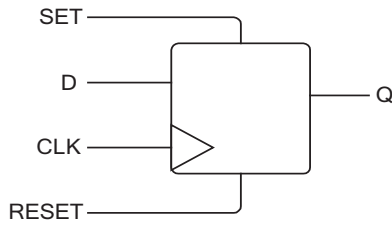

Figure 3: Logic Cell Flip-Flop

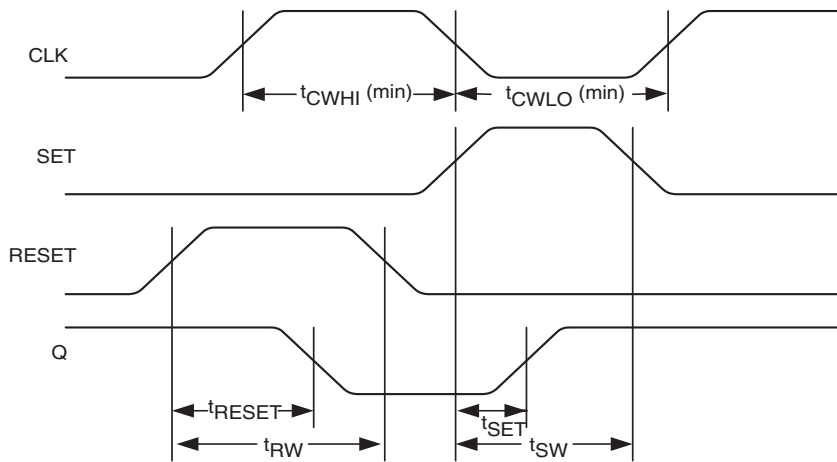

Figure 4: Logic Cell Flip-Flop Timings—First Waveform

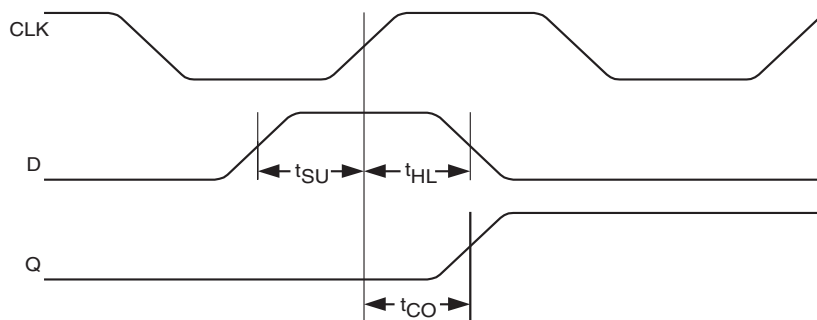

Figure 5: Logic Cell Flip-Flop Timings—Second Waveform

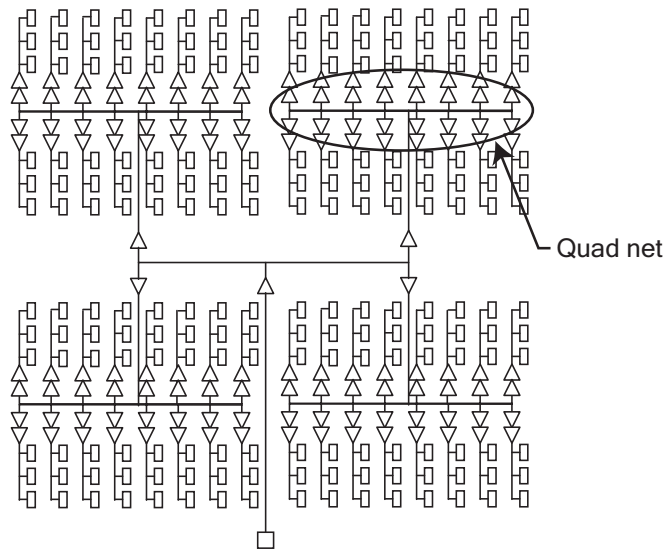

Figure 6: EclipsePlus Global Clock Structure

Table 2: EclipsePlus Clock Delay

Clock Source	Parameters	Clock Performance	
		Global	Dedicated
Logic Cells (Internal)	Clock signal generated internally	1.51 ns (max)	
Clock Pad	Clock signal generated externally	2.06 ns (max)	1.73 ns (max)

Table 3: EclipsePlus Global Clock Delay

Clock Segment	Parameter	Value	
		Min	Max
$t_{PGCK}^a$	Global clock pin delay to quad net	-	1.34 ns
$t_{BGCK}$	Global clock tree delay (quad net to flip-flop)	-	0.56 ns

a. When using a PLL,  $t_{PGCK}$  and  $t_{BGCK}$  are effectively zero due to delay adjustment by Phase Locked Loop

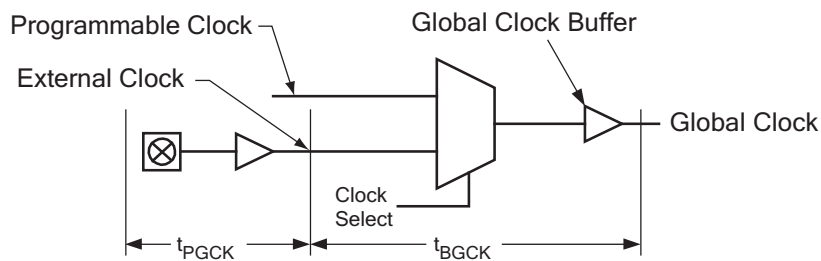

Figure 7: Global Clock Structure Schematic

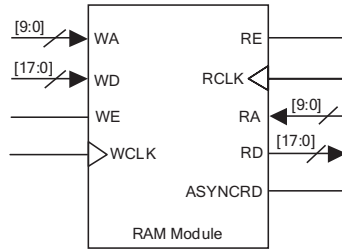

Figure 8: RAM Module

Table 4: RAM Cell Synchronous Write Timing

Symbol	Parameter	Value	
		Min	Max
<b>RAM Cell Synchronous Write Timing</b>			
$t_{SWA}$	WA setup time to WCLK: time the WRITE ADDRESS must be stable before the active edge of the WRITE CLOCK	0.675 ns	-
$t_{HWA}$	WA hold time to WCLK: time the WRITE ADDRESS must be stable after the active edge of the WRITE CLOCK	0 ns	-
$t_{SWD}$	WD setup time to WCLK: time the WRITE DATA must be stable before the active edge of the WRITE CLOCK	0.654 ns	-
$t_{HWD}$	WD hold time to WCLK: time the WRITE DATA must be stable after the active edge of the WRITE CLOCK	0 ns	-
$t_{SWE}$	WE setup time to WCLK: time the WRITE ENABLE must be stable before the active edge of the WRITE CLOCK	0.623 ns	-
$t_{HWE}$	WE hold time to WCLK: time the WRITE ENABLE must be stable after the active edge of the WRITE CLOCK	0 ns	-
$t_{WCRD}$	WCLK to RD (WA = RA): time between the active WRITE CLOCK edge and the time when the data is available at RD	-	4.38 ns

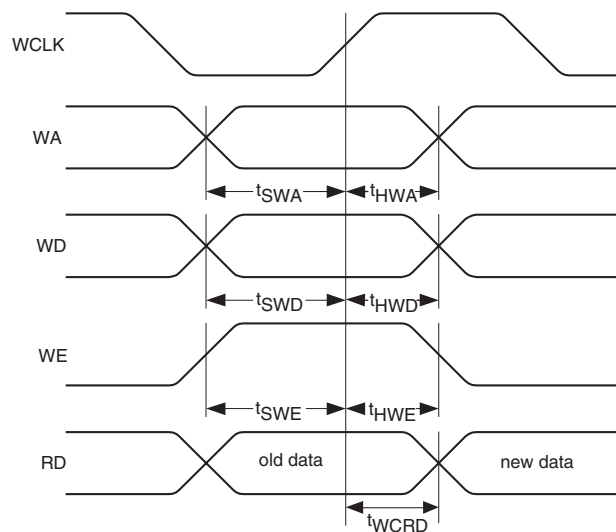

Figure 9: RAM Cell Synchronous Write Timing

Table 5: RAM Cell Synchronous & Asynchronous Read Timing

Symbol	Parameter	Value	
		Min	Max
<b>RAM Cell Synchronous Read Timing</b>			
$t_{SRA}$	RA setup time to RCLK: time the READ ADDRESS must be stable before the active edge of the READ CLOCK	0.686 ns	-
$t_{HRA}$	RA hold time to RCLK: time the READ ADDRESS must be stable after the active edge of the READ CLOCK	0 ns	-
$t_{SRE}$	RE setup time to WCLK: time the READ ENABLE must be stable before the active edge of the READ CLOCK	0.243 ns	-
$t_{HRE}$	RE hold time to WCLK: time the READ ENABLE must be stable after the active edge of the READ CLOCK	0 ns	-
$t_{RCRD}$	RCLK to RD: time between the active READ CLOCK edge and the time when the data is available at RD	-	4.38 ns
<b>RAM Cell Asynchronous Read Timing</b>			
$t_{PDRD}$	RA to RD: time between when the READ ADDRESS is input and when the DATA is output	-	2.06 ns

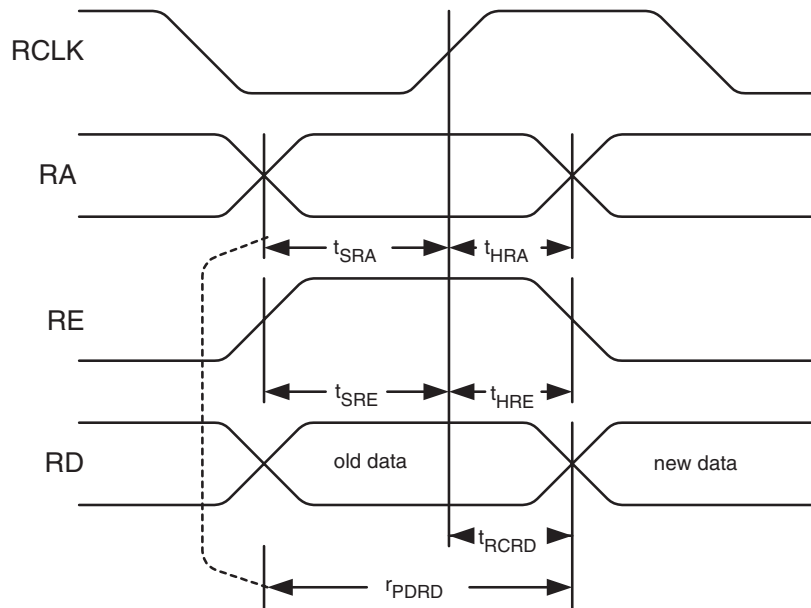

Figure 10: RAM Cell Synchronous & Asynchronous Read Timing

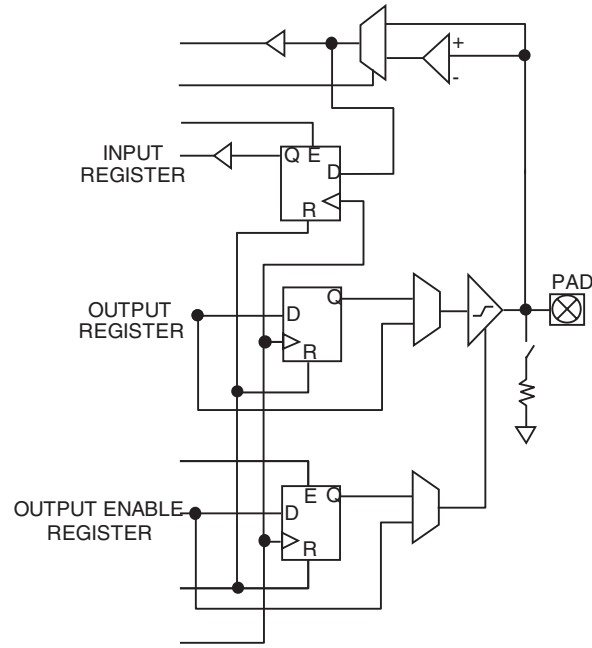

Figure 11: EclipsePlus Cell I/O

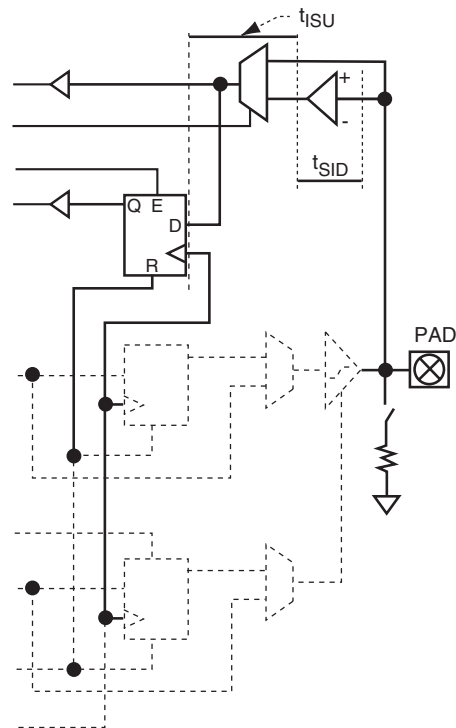

Figure 12: EclipsePlus Input Register Cell

Table 6: Input Register Cell

Symbol	Parameter	Value	
		Min	Max
<b>Input Register Cell Only</b>			
$t_{ISU}$	Input register setup time: time the synchronous input of the flip-flop must be stable before the active clock edge	3.12 ns	-
$t_{IHL}$	Input register hold time: time the synchronous input of the flip-flop must be stable after the active clock edge	0 ns	-
$t_{ICO}$	Input register clock-to-out: time taken by the flip-flop to output after the active clock edge	-	1.08 ns
$t_{IRST}$	Input register reset delay: time between when the flip-flop is “reset”(low) and when the output is consequently “reset” (low)	-	0.99 ns
$t_{IESU}$	Input register clock enable setup time: time “enable” must be stable before the active clock edge	0.37 ns	-
$t_{IEH}$	Input register clock enable hold time: time “enable” must be stable after the active clock edge	0 ns	-

Table 7: Standard Input Delays

Symbol	Parameter	Value	
		Min	Max
<b>Standard Input Delays</b>			
$t_{SID}$ (LVTTTL)	LVTTTL input delay: Low Voltage TTL for 3.3 V applications	-	0.34 ns
$t_{SID}$ (LVCMOS2)	LVCMOS2 input delay: Low Voltage CMOS for 2.5 V and lower applications	-	0.42 ns
$t_{SID}$ (GTL+)	GTL+ input delay: Gunning Transceiver Logic	-	0.68 ns
$t_{SID}$ (SSTL3)	SSTL3 input delay: Stub Series Terminated Logic for 3.3 V	-	0.55 ns
$t_{SID}$ (SSTL2)	SSTL2 input delay: Stub Series Terminated Logic for 2.5 V	-	0.61 ns

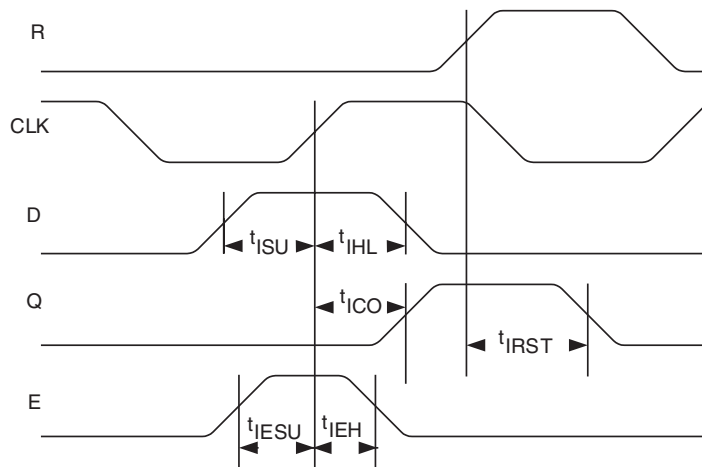

Figure 13: EclipsePlus Input Register Cell Timing



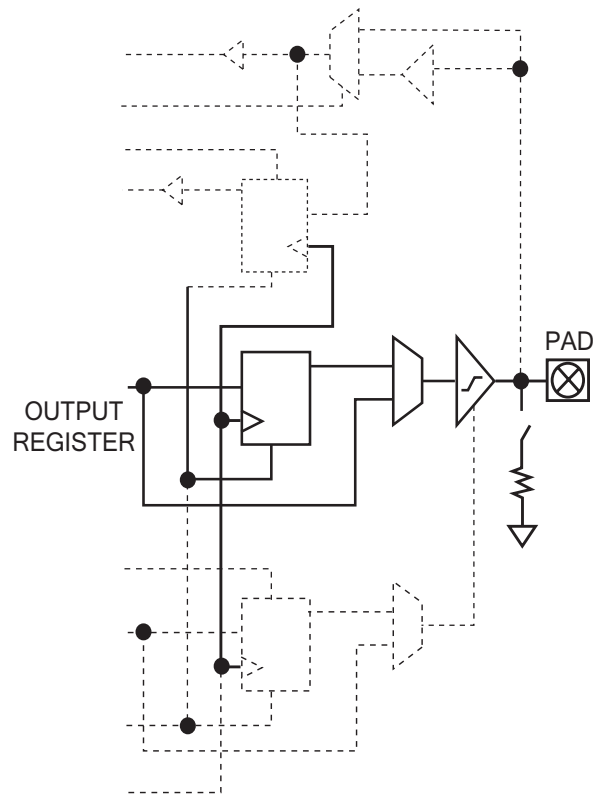

Figure 14: EclipsePlus Output Register Cell

Table 8: EclipsePlus Output Register Cell

Symbol	Parameter	Value	
		Min	Max
<b>Output Register Cell Only</b>			
$t_{OUTLH}$	Output Delay low to high (90% of H)	-	0.40 ns
$t_{OUTHl}$	Output Delay high to low (10% of L)	-	0.55 ns
$t_{PZH}$	Output Delay tri-state to high (90% of H)	-	2.94 ns
$t_{PZL}$	Output Delay tri-state to low (10% of L)	-	2.34 ns
$t_{PHZ}$	Output Delay high to tri-State	-	3.07 ns
$t_{PLZ}$	Output Delay low to tri-State	-	2.53 ns
$t_{COP}$	Clock-to-out delay (does not include clock tree delays)	-	3.15 ns (fast slew) 10.2 ns (slow slew)

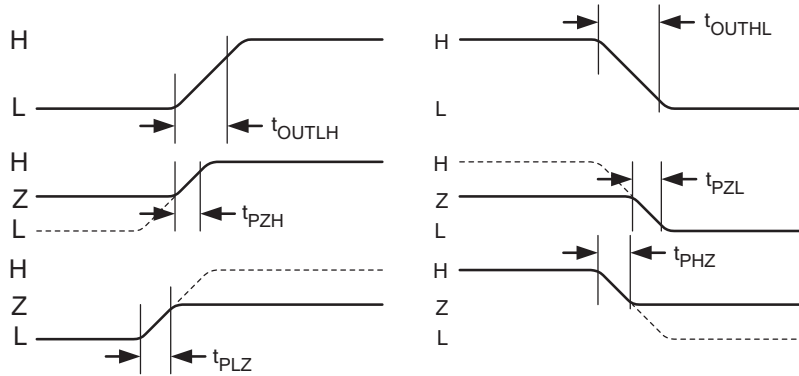

Figure 15: EclipsePlus Output Register Cell Timing

Table 9: Output Slew Rates @  $V_{CCIO} = 3.3\text{ V}$

	Fast Slew	Slow Slew
Rising Edge	2.8 V/ns	1.0 V/ns
Falling Edge	2.86 V/ns	1.0 V/ns

Table 10: Output Slew Rates @  $V_{CCIO} = 2.5\text{ V}$

	Fast Slew	Slow Slew
Rising Edge	1.7 V/ns	0.6 V/ns
Falling Edge	1.9 V/ns	0.6 V/ns

## DC Characteristics

The DC Specifications are provided in **Table 11** through **Table 13**.

Table 11: Absolute Maximum Ratings

Parameter	Value	Parameter	Value
V <sub>CC</sub> Voltage	-0.5 V to 3.6 V	DC Input Current	±20 mA
V <sub>CCIO</sub> Voltage	-0.5 V to 4.6 V	ESD Pad Protection	±2000 V
INREF Voltage	2.7 V	Leaded Package Storage Temperature	-65° C to + 150° C
Input Voltage	-0.5 V to V <sub>CCIO</sub> +0.5 V	Laminate Package (BGA) Storage Temperature	-55° C to + 125° C
Latch-up Immunity	±100 mA		

Table 12: Operating Range

Symbol	Parameter	Military		Industrial		Commercial		Unit	
		Min	Max	Min	Max	Min	Max		
V <sub>CC</sub>	Supply Voltage	2.3	2.7	2.3	2.7	2.3	2.7	V	
V <sub>CCIO</sub>	I/O Input Tolerance Voltage	2.3	3.6	2.3	3.6	2.3	3.6	V	
TA	Ambient Temperature	-55		-40	85	0	70	°C	
TC	Case Temperature	-	125	-	-	-	-	°C	
K	Delay Factor	-4 Speed Grade	0.42	2.3	0.43	2.16	0.47	2.11	n/a
		-5 Speed Grade	0.42	1.92	0.43	1.80	0.46	1.76	n/a
		-6 Speed Grade	0.42	1.35	0.43	1.26	0.46	1.23	n/a
		-7 Speed Grade	0.42	1.28	0.43	1.19	0.46	1.16	n/a

Table 13: DC Characteristics

Symbol	Parameter	Conditions	Min	Max	Units
I <sub>I</sub>	I or I/O Input Leakage Current	V <sub>I</sub> = V <sub>CCIO</sub> or GND	-10	10	μA
I <sub>OZ</sub>	3-State Output Leakage Current	V <sub>I</sub> = V <sub>CCIO</sub> or GND	-10	10	μA
C <sub>I</sub>	Input Capacitance <sup>a</sup>	-	-	8	pF
I <sub>OS</sub>	Output Short Circuit Current <sup>b</sup>	V <sub>o</sub> = GND V <sub>o</sub> = V <sub>CC</sub>	-15 40	-180 210	mA mA
I <sub>CC</sub>	D.C. Supply Current <sup>c</sup>	V <sub>I</sub> , V <sub>o</sub> = V <sub>CCIO</sub> or GND	0.50 (typ)	2	mA
I <sub>CCIO</sub>	D.C. Supply Current on V <sub>CCIO</sub>	-	0	2	mA
I <sub>CCIO(DIF)</sub>	D.C. Supply Current on V <sub>CCIO</sub> for Differential I/O	-	-	-	mA
I <sub>REF</sub>	D.C. Supply Current on INREF	-	-10	10	μA
I <sub>PD</sub>	Pad Pull-down (programmable)	V <sub>CCIO</sub> = 3.6 V	-	150	μA

a. Capacitance is sample tested only. Clock pins are 12 pF maximum.

b. Only one output at a time. Duration should not exceed 30 seconds.

c. For -4/-5/-6/-7 commercial grade devices only. Maximum I<sub>CC</sub> is 3 mA for -0 commercial grade and all industrial grade devices, and 5 mA for all military grade devices.

## Embedded Computational Unit (ECU)

Traditional Programmable Logic architectures do not implement arithmetic functions efficiently or effectively—these functions require high logic cell usage while garnering only moderate performance results.

The QL7160 architecture allows for functionality above and beyond that achievable using programmable logic devices. By embedding a dynamically reconfigurable computational unit, the QL7160 device can address various arithmetic functions efficiently. This approach offers greater performance than traditional programmable logic implementations. The embedded block is implemented at the transistor level as shown in **Figure 16**.

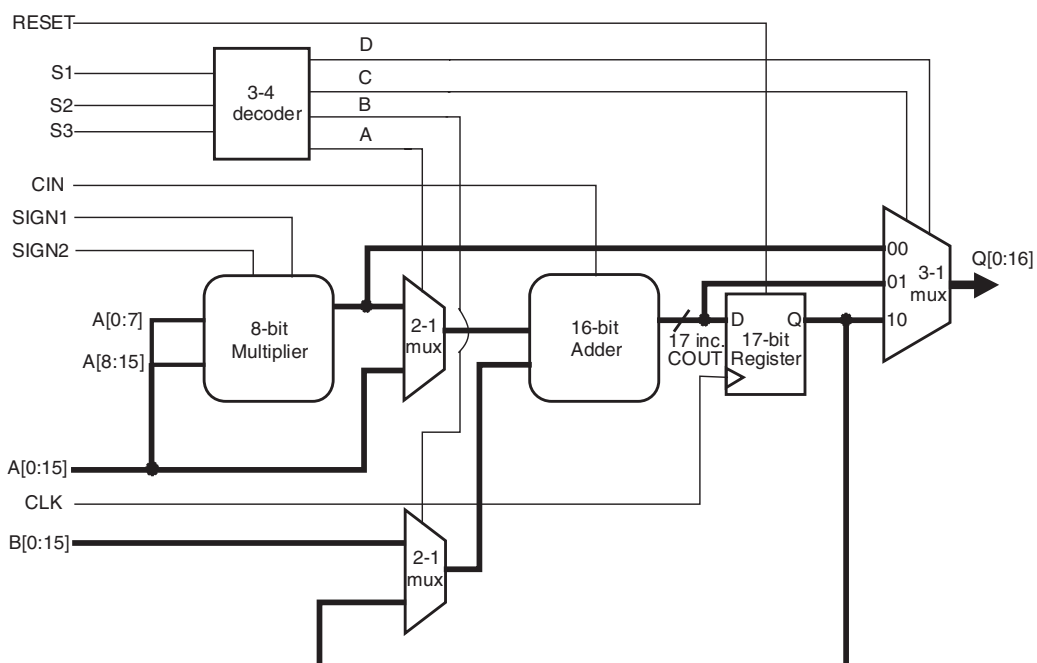

Figure 16: ECU Block Diagram

The 16 QL7160 ECU blocks are placed next to the SRAM circuitry for efficient memory/instruction fetch and addressing for DSP algorithmic implementations.

Sixteen 8-bit Multiply-Accumulate (MAC) functions can be implemented per cycle for a total of 1.6 billion MACs when clocked at 100 MHz. Additional MAC functions can be implemented in the programmable logic.

The modes for the ECU block are dynamically re-programmable through the programmable logic as shown in **Table 14**.

Table 14: ECU Mode Select Criteria

Instruction			Operation	ECU Performance <sup>a</sup> , -7 WCC <sup>b</sup>		
S1	S2	S3		t <sub>PD</sub>	t <sub>SU</sub>	t <sub>CO</sub>
0	0	0	Multiply	6.57 ns max		
0	0	1	Multiply-Add	8.84 ns max		
0	1	0	Accumulate <sup>c</sup>		3.91 ns min	1.16 ns max
0	1	1	Add	3.14 ns max		
1	0	0	Multiply (registered) <sup>d</sup>		9.61 ns min	1.16 ns max
1	0	1	Multiply- Add (registered)		9.61 ns min	1.16 ns max
1	1	0	Multiply - Accumulate		9.61 ns min	1.16 ns max
1	1	1	Add (registered)		3.91 ns min	1.16 ns max

- a. t<sub>PD</sub>, t<sub>SU</sub> and t<sub>CO</sub> do not include routing paths in/out of the ECU block.  
b. Timing numbers represent -7 Worst Case Commercial conditions.  
c. Internal feedback path in ECU restricts max clk frequency to 238 MHz.  
d. B [15:0] set to zero.

## Phase Locked Loops (PLLs)

Instead of requiring extra components, designers simply need to instantiate one of the pre-configured models described in this section and listed in [Table 15](#). The QuickLogic built-in PLLs support a wider range of frequencies than many other PLLs. Also, QuickLogic PLLs can be cascaded to support different ranges of frequency multiplications or divisions, driving the device at a faster or slower rate than the incoming clock frequency. Most importantly, they achieve a very short clock-to-out time—generally less than 3 ns. This low clock-to-out time is achieved by the PLL subtracting the clock tree delay through the feedback path, effectively making the clock tree delay zero.

**Figure 17** illustrates a typical QuickLogic ESP PLL.

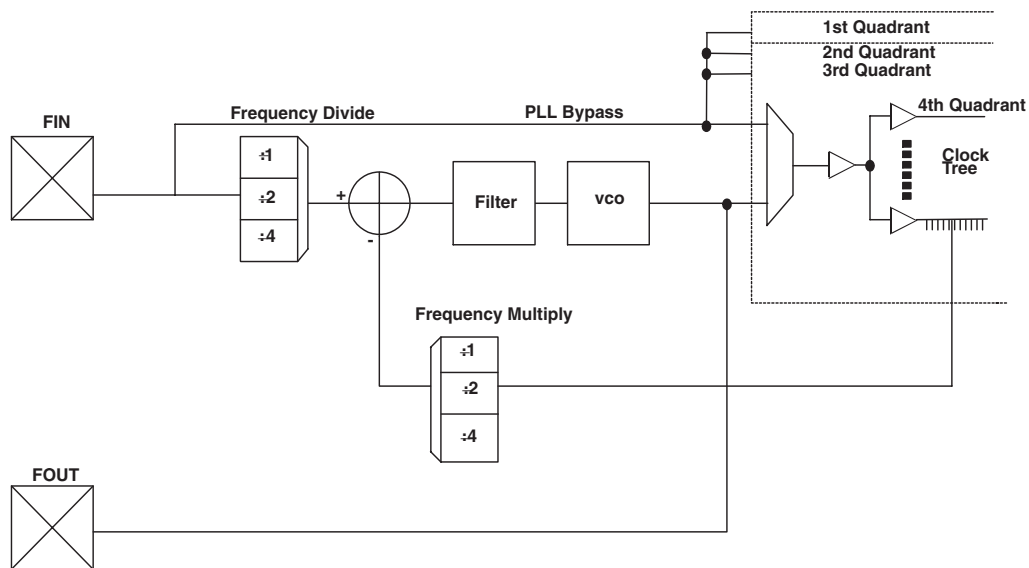

*Figure 17: PLL Block*

$F_{in}$  represents a very stable high-frequency input clock and produces an accurate signal reference. This signal can either bypass the PLL entirely, thus entering the clock tree directly, or it can pass through the PLL itself.

Within the PLL, a voltage-controlled oscillator (VCO) is added to the circuit. The external  $F_{in}$  signal and the local VCO form a control loop. The VCO is multiplied or divided down to the reference frequency, so that a phase detector (the crossed circle in [Figure 17](#)) can compare the two signals. If the phases of the external and local signals are not within the tolerance required, the phase detector sends a signal through the charge pump and loop filter ([Figure 17](#)). The charge pump generates an error voltage to bring the VCO back into alignment and the loop filter removes any high frequency noise before the error voltage enters the VCO. This new VCO signal enters the clock tree to drive the chip's circuitry.

$F_{out}$  represents the clock signal that emerges from the output pad (the output signal PLLPAD\_OUT is explained in [Table 16](#)). This clock signal is meaningful only when the PLL is configured for external use; otherwise, it remains in high Z state, as shown in the post-simulation waveform.

Most QuickLogic products contain four PLLs, one to be used in each quadrant. The PLL presented in **Figure 17** controls the clock tree in the fourth Quadrant of its ESP. As previously mentioned, QuickLogic PLLs compensate for the additional delay created by the clock tree itself by subtracting the clock tree delay through the feedback path.

For more specific information on the Phase Locked Loops, please refer to Application Note 58 at <http://www.quicklogic.com/images/appnote58.pdf>

## PLL Modes of Operation

QuickLogic PLLs have eight modes of operation, based on the input frequency and desired output frequency—**Table 15** indicates the features of each mode.

Table 15: PLL Mode Frequencies

PLL Model	Output Frequency	Input Frequency Range <sup>a</sup>	Output Frequency Range
PLL_HF <sup>b</sup>	Same as input frequency	66 MHz–150 MHz	66 MHz–150 MHz
PLL_LF	Same as input frequency	25 MHz–133 MHz	25 MHz–133 MHz
PLL_MULT2HF	2 × input frequency	50 MHz–125 MHz	100 MHz–250 MHz
PLL_MULT2LF	2 × input frequency	16 MHz–50 MHz	32 MHz–100 MHz
PLL_DIV2HF	1/2 × input frequency	100 MHz–250 MHz	50 MHz–125 MHz
PLL_DIV2LF	1/2 × input frequency	50 MHz–100 MHz	25 MHz–50 MHz
PLL_MULT4	4 × input frequency	16 MHz–40 MHz	64 MHz–160 MHz
PLL_DIV4	1/4 × input frequency	100 MHz–300 MHz	25 MHz–75 MHz

- a. The input frequency can range from 12.5 MHz to 500 MHz, while output frequency ranges from 25 MHz to 250 MHz. When you add PLLs to your top-level design, be sure that the PLL mode matches your desired input and output frequencies.
- b. HF stands for high frequency and LF stands for low frequency.

## PLL Signals

Table 16 summarizes the key signals in QuickLogic's PLLs.

Table 16: PLL Signals

Signal Name	Description
PLLCLK_IN	Input clock signal
PLL_RESET	<b>Active High Reset</b> If PLL_RESET is asserted, then CLKNET_OUT and PLLPAD_OUT are reset to 0. This signal must be asserted and then released in order for the LOCK_DETECT to work.
ONn_OFFCHIP	<b>PLL output</b> This signal selects whether the PLL will drive the internal clock network or be used off-chip. This is a static signal, not a dynamic signal. Tied to GND = outgoing signal drives internal gates. Tied to VCC = outgoing signal used off-chip.
CLKNET_OUT	<b>Out to internal gates</b> This signal bypasses the PLL logic before driving the internal gates. Note that this signal cannot be used in the same quadrant where the PLL signal is used (PLLCLK_OUT).
PLLCLK_OUT	<b>Out from PLL to internal gates</b> This signal can drive the internal gates after going through the PLL. For this to work, ONn_OFFCHIP must be tied to GND.
PLLPAD_OUT	<b>Out to off-chip</b> This outgoing signal is used off-chip. For this to work, ONn_OFFCHIP signal must be tied to VCC.
LOCK_DETECT	<b>Active High Lock detection signal</b> NOTE: For simulation purposes, this signal gets asserted after 10 clock cycles. However, it can take a maximum of 200 clock cycles to sync with the input clock upon release of the RESET signal.

**NOTE:** Because PLLCLK\_IN and PLL\_RESET signals have INPAD, and PLLPAD\_OUT has OUTPAD, you do not have to add additional pads to your design



## I/O Characteristics

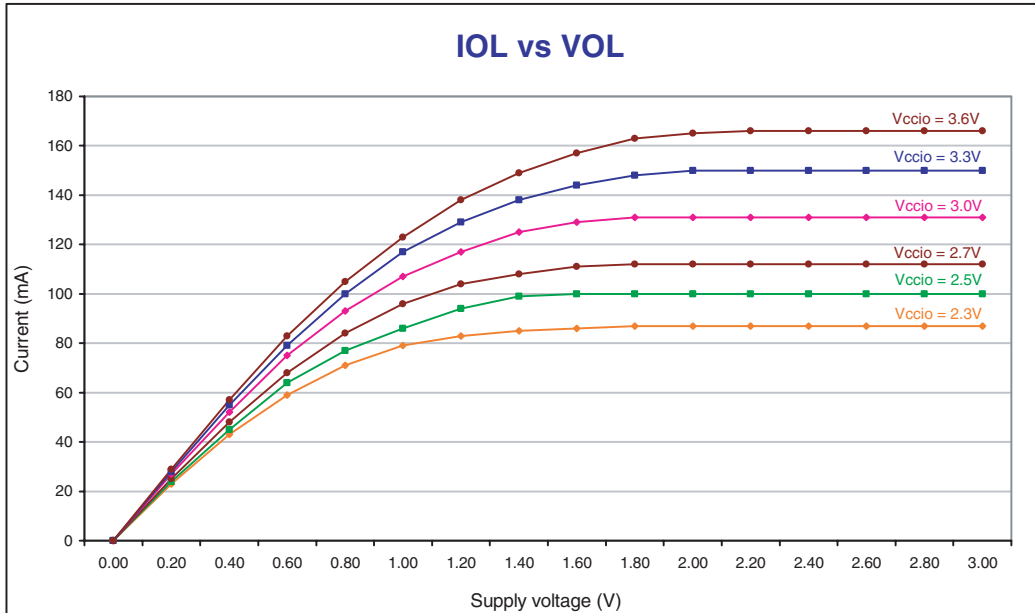

Figure 18: IOL vs. VOL

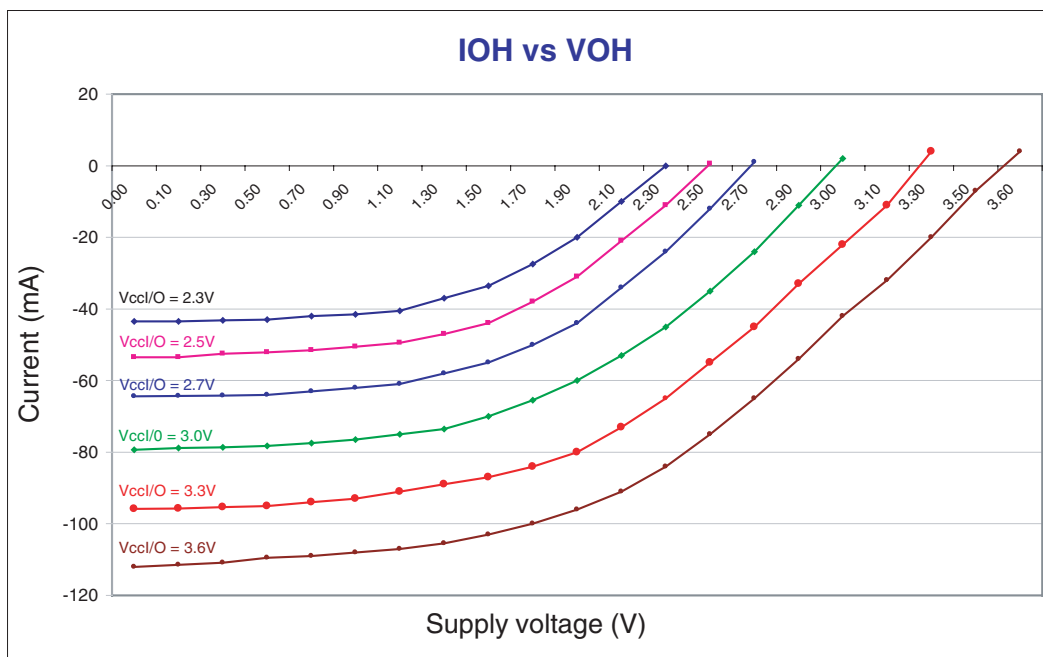

Figure 19: IOH vs. VOH

Table 17: DC Input and Output Levels<sup>a</sup>

	INREF		$V_{IL}$		$V_{IH}$		$V_{OL}$	$V_{OH}$	$I_{OL}$	$I_{OH}$
	$V_{MIN}$	$V_{MAX}$	$V_{MIN}$	$V_{MAX}$	$V_{MIN}$	$V_{MAX}$	$V_{MAX}$	$V_{MIN}$	mA	mA
LVTTTL	n/a	n/a	-0.3	0.8	2.0	$V_{CCIO} + 0.3$	0.4	2.4	2.0	-2.0
LVC MOS2	n/a	n/a	-0.3	0.7	1.7	$V_{CCIO} + 0.3$	0.7	1.7	2.0	-2.0
GTL+	0.88	1.12	-0.3	INREF - 0.2	INREF + 0.2	$V_{CCIO} + 0.3$	0.6	n/a	40	n/a
PCI	n/a	n/a	-0.3	$0.3 \times V_{CCIO}$	$0.5 \times V_{CCIO}$	$V_{CCIO} + 0.5$	$0.1 \times V_{CCIO}$	$0.9 \times V_{CCIO}$	1.5	-0.5
SSTL2	1.15	1.35	-0.3	INREF - 0.18	INREF + 0.18	$V_{CCIO} + 0.3$	0.74	1.76	7.6	-7.6
SSTL3	1.3	1.7	-0.3	INREF - 0.2	INREF + 0.2	$V_{CCIO} + 0.3$	1.10	1.90	8	-8

a. The data provided in **Table 17** are JEDEC and PCI Specifications. QuickLogic devices either meet or exceed these requirements. For data specific to QuickLogic I/Os, see preceding **Table 1** through **Table 13** and **Figure 1** through **Figure 17**.

**NOTE:** All CLK and IOCTRL pins are clamped to the  $V_{CC}$  rail, not the  $V_{CCIO}$ . Therefore, these pins can only be driven up to  $V_{CC} + 0.3 V$ .

## Package Thermal Characteristics

Thermal Resistance Equations:

$$\theta_{JC} = (T_J - T_C) / P$$

$$\theta_{JA} = (T_J - T_A) / P$$

$$P_{MAX} = (T_{JMAX} - T_{AMAX}) / \theta_{JA}$$

Parameter Description:

$\theta_{JC}$ : Junction-to-case thermal resistance

$\theta_{JA}$ : Junction-to-ambient thermal resistance

$T_J$ : Junction temperature

$T_A$ : Ambient temperature

P: Power dissipated by the device while operating

$P_{MAX}$ : The maximum power dissipation for the device

$T_{JMAX}$ : Maximum junction temperature

$T_{AMAX}$ : Maximum ambient temperature

**NOTE:** Maximum junction temperature ( $T_{JMAX}$ ) is 150° C. To calculate the maximum power dissipation for a device package look up  $\theta_{JA}$  from **Table 18**, pick an appropriate  $T_{AMAX}$  and use:

$$P_{MAX} = (150^\circ \text{ C} - T_{AMAX}) / \theta_{JA}$$

Table 18: Package Thermal Characteristics

Package Description		$\theta_{JA}$ (° C/W) @ various flow rates (m/sec)				$\theta_{JC}$ (° C/W)
Pin Count	Package Type	0	0.5	1	2	
672	PBGA	22.0	20.0	19.0	18.0	8.0
516	PBGA	20.0	19.0	17.5	16.0	7.0
484	PBGA	28.0	26.0	25.0	23.0	9.0
280	LF-PBGA	18.5	17.0	15.5	14.0	7.0

## Kv and Kt Graphs

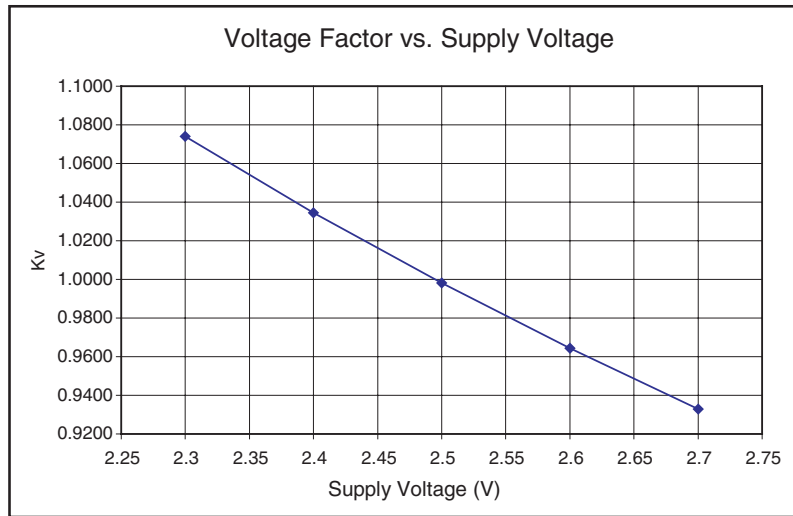

Figure 20: Voltage Factor vs. Supply Voltage

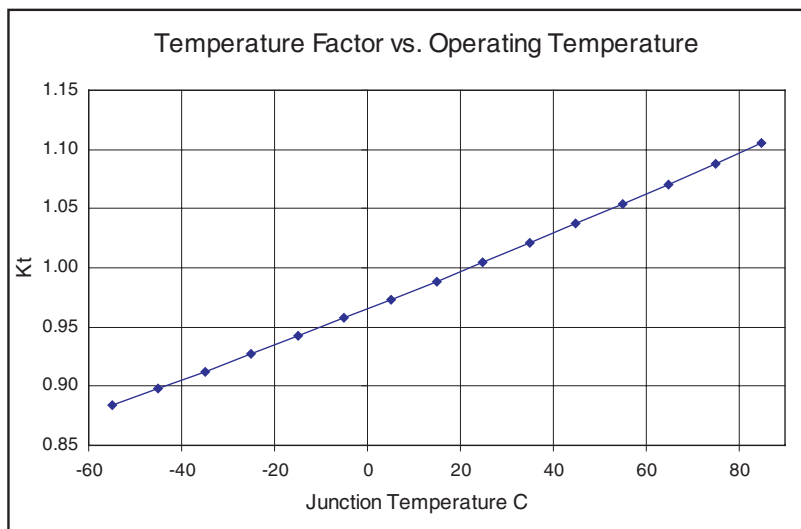

Figure 21: Temperature Factor vs. Operating Temperature

## Power vs. Operating Frequency

The basic power equation which best models power consumption is given below:

$$P_{TOTAL} = 0.350 + f[0.0031 \eta_{LC} + 0.0948 \eta_{CKBF} + 0.01 \eta_{CLBF} + 0.0263 \eta_{CKLD} + 0.543 \eta_{RAM} + 0.20 \eta_{PLL} + 0.0035 \eta_{INP} + 0.0257 \eta_{OUTP}] \text{ (mW)}$$

Where

- $\eta_{LC}$  is the total number of logic cells in the design
- $\eta_{CKBF}$  = # of clock buffers
- $\eta_{CLBF}$  = # of column clock buffers
- $\eta_{CKLD}$  = # of loads connected to the column clock buffers
- $\eta_{RAM}$  = # of RAM blocks
- $\eta_{PLL}$  = # of PLLs
- $\eta_{INP}$  is the number of input pins
- $\eta_{OUTP}$  is the number of output pins

**Figure 22** exhibits the power consumption in an EclipsePlus QL7160 device. The chip was filled with (300) 8-bit counters—approximately 76% logic cell utilization.

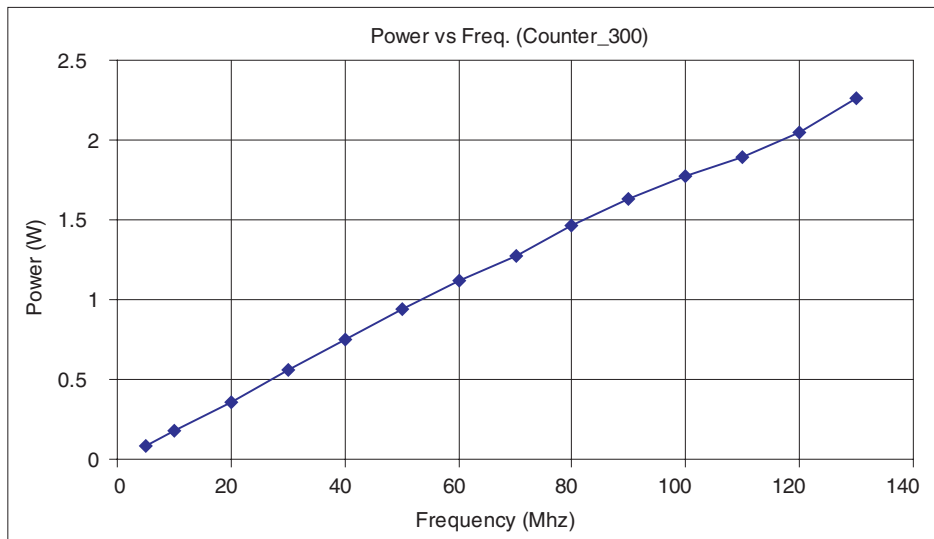

Figure 22: Power Consumption

**Figure 23** illustrates the theoretical worst-case scenarios for 50%, 70%, and 90% utilizations of the 6600-516 package. The resources of the device are divided exactly in half; meaning, for 50% utilization, exactly 50% of the I/Os, Logic Cells, RAM blocks, clock network, etc. are utilized. These situations may never occur in a real design, but they do provide a very rough quantitative measure of power consumption when talking in terms of 50% or 70% utilization of an EclipsePlus device.

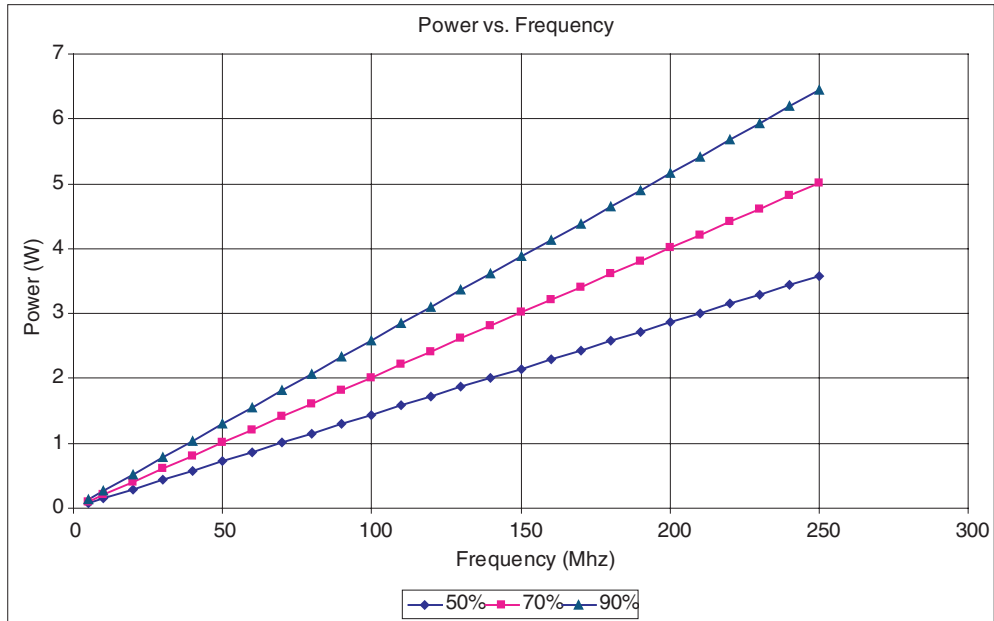

Figure 23: Power vs. Frequency (Absolute 50%, 70%, and 90% of the Available Resources on Chip)

To learn more about power consumption, please refer to application note #60 which is located at <http://www.quicklogic.com./images/appnote60.pdf>

## Power-up Sequencing

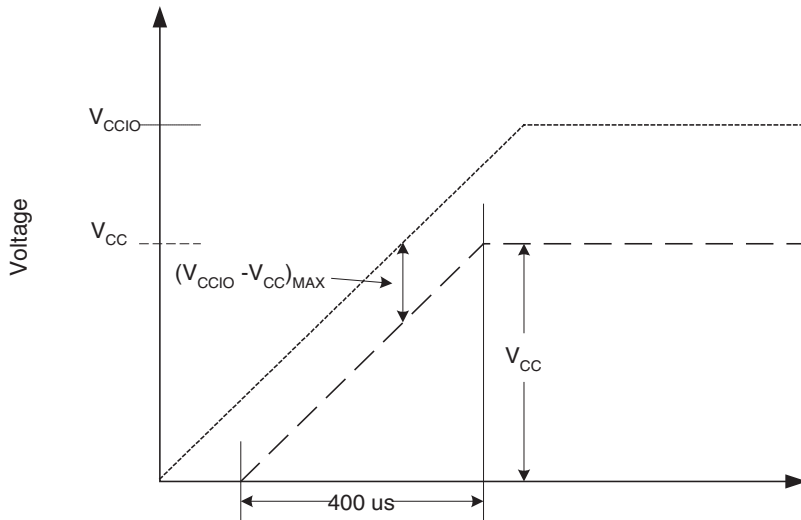

Figure 24: Power-up Requirements

The following requirements must be met when powering up a device (refer to **Figure 24**):

- When ramping up the power supplies keep  $(V_{CCIO} - V_{CC})_{MAX} \leq 500$  mV. Deviation from this recommendation can cause permanent damage to the device.
- $V_{CCIO}$  must lead  $V_{CC}$  when ramping the device.
- The power supply must be greater than or equal to 400  $\mu$ s to reach  $V_{CC}$ . Ramping to  $V_{CC}/V_{CCIO}$  before reaching 400  $\mu$ s can cause the device to behave improperly.

A diode is present in-between  $V_{CC}$  and  $V_{CCIO}$ , as shown in **Figure 25**.

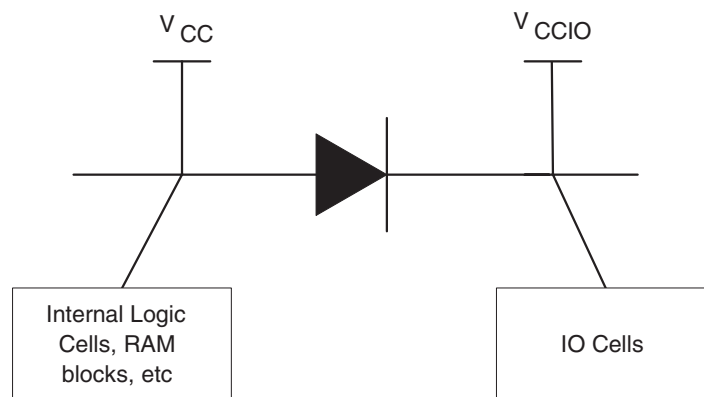

Figure 25: Internal Diode Between  $V_{CC}$  and  $V_{CCIO}$

## Joint Test Access Group (JTAG)

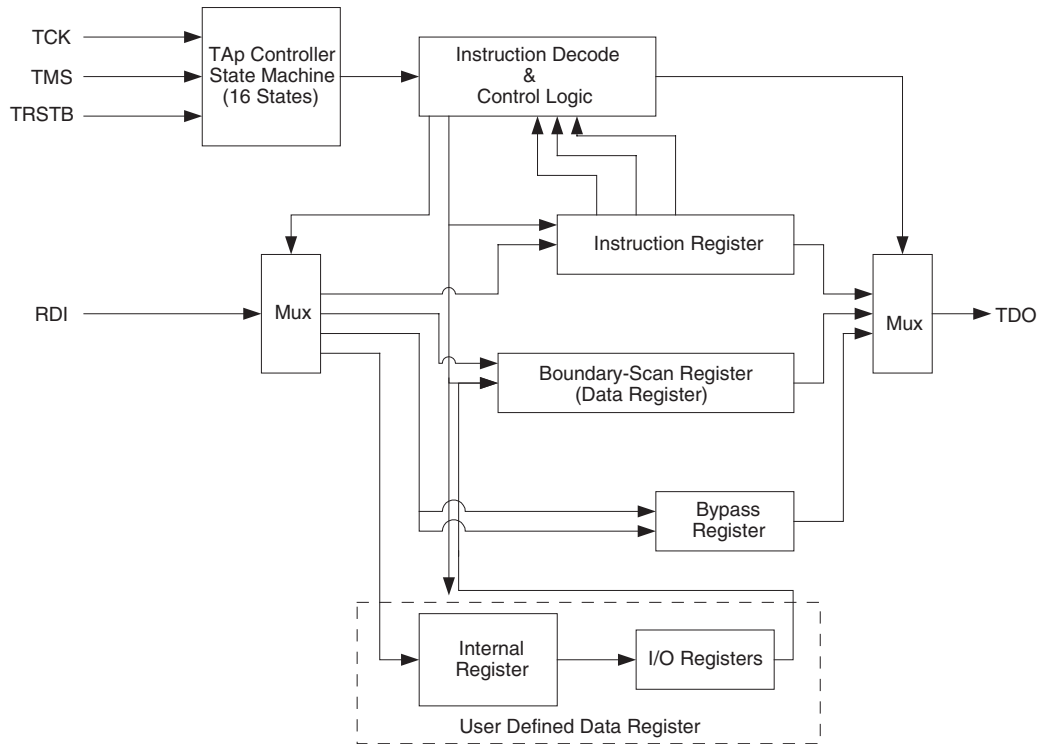

Figure 26: JTAG Block Diagram

Microprocessors and Application Specific Integrated Circuits (ASICs) pose many design challenges, one problem being the accessibility of test points. The Joint Test Access Group (JTAG) formed in response to this challenge, resulting in IEEE standard 1149.1, the Standard Test Access Port and Boundary Scan Architecture.

The JTAG boundary scan test methodology allows complete observation and control of the boundary pins of a JTAG-compatible device through JTAG software. A Test Access Port (TAP) controller works in concert with the Instruction Register (IR), which allow users to run three required tests along with several user-defined tests.

JTAG tests allow users to reduce system debug time, reuse test platforms and tools, and reuse subsystem tests for fuller verification of higher level system elements.



The 1149.1 standard requires the following three tests:

- **Extest Instruction.** The Extest instruction performs a PCB interconnect test. This test places a device into an external boundary test mode, selecting the boundary scan register to be connected between the TAP's Test Data In (TDI) and Test Data Out (TDO) pins. Boundary scan cells are preloaded with test patterns (via the Sample/Preload Instruction), and input boundary cells capture the input data for analysis.
- **Sample/Preload Instruction.** This instruction allows a device to remain in its functional mode, while selecting the boundary scan register to be connected between the TDI and TDO pins. For this test, the boundary scan register can be accessed via a data scan operation, allowing users to sample the functional data entering and leaving the device.
- **Bypass Instruction.** The Bypass instruction allows data to skip a device's boundary scan entirely, so the data passes through the bypass register. The Bypass instruction allows users to test a device without passing through other devices. The bypass register is connected between the TDI and TDO pins, allowing serial data to be transferred through a device without affecting the operation of the device.

## Pin Descriptions

Table 19: JTAG Pin Descriptions

Pin	Function	Description
TDI/RSI	Test Data In for JTAG/RAM init. Serial Data In	Hold HIGH during normal operation. Connects to serial PROM data in for RAM initialization. Connect to V <sub>CC</sub> if unused
TRSTB/RRO	Active low Reset for JTAG/RAM init. reset out	Hold LOW during normal operation. Connects to serial PROM reset for RAM initialization. Connect to GND if unused
TMS	Test Mode Select for JTAG	Hold HIGH during normal operation. Connect to V <sub>CC</sub> if not used for JTAG
TCK	Test Clock for JTAG	Hold HIGH or LOW during normal operation. Connect to V <sub>CC</sub> or ground if not used for JTAG
TDO/RCO	Test data out for JTAG/RAM init. clock out	Connect to serial PROM clock for RAM initialization. Must be left unconnected if not used for JTAG or RAM initialization

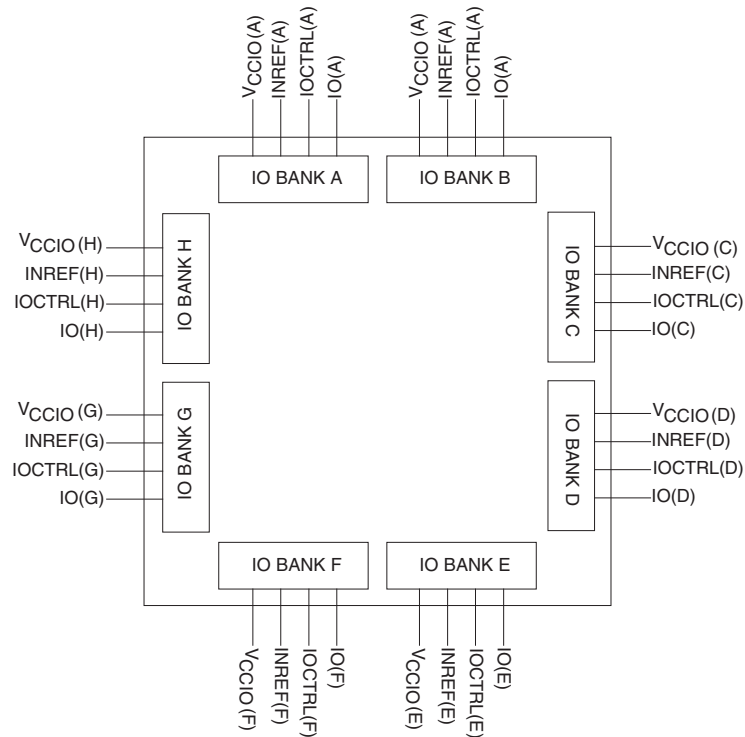

Figure 27: I/O Banks with Relevant Pins

Table 20: Dedicated Pin Descriptions

Pin	Function	Description
GCLK	Global clock network driver	Low skew global clock. This pin provides access to a dedicated, distributed network capable of driving the CLOCK, SET, RESET, F1, and A2 inputs to the Logic Cell, READ, and WRITE CLOCKS, Read and Write Enables of the Embedded RAM Blocks, CLOCK of the ECUs, and Output Enables of the I/Os.
I/O(A)	Input/Output pin	The I/O pin is a bi-directional pin, configurable to either an input-only, output-only, or bi-directional pin. The A inside the parenthesis means that the I/O is located in Bank A. If an I/O is not used, SpDE (QuickWorks Tool) provides the option of tying that pin to GND, V <sub>CC</sub> , or TriState during programming.
V <sub>CC</sub>	Power supply pin	Connect to 2.5 V supply
V <sub>CCIO</sub> (A)	Input voltage tolerance pin	This pin provides the flexibility to interface the device with either a 3.3 V device or a 2.5 V device. The A inside the parenthesis means that V <sub>CCIO</sub> is located in BANK A. Every I/O pin in Bank A will be tolerant of V <sub>CCIO</sub> input signals and will output V <sub>CCIO</sub> level signals. This pin must be connected to either 3.3 V or V <sub>CC</sub> .
GND	Ground pin	Connect to ground
PLLIN	PLL clock input	Clock input for PLL
DEDCLK	Dedicated clock pin	Low skew global clock. This pin provides access to a dedicated, distributed clock network capable of driving the CLOCK inputs of all sequential elements of the device (e.g. RAM, Flip Flops).
GNDPLL	Ground pin for PLL	Connect to GND
INREF(A)	Differential reference voltage	The INREF is the reference voltage pin for GTL+, SSTL2, and STTL3 standards. Follow the recommendations provided in <a href="#">Table 17</a> for the appropriate standard. The A inside the parenthesis means that INREF is located in BANK A. This pin should be tied to GND if not needed.
PLLOUT	PLL output pin	Dedicated PLL output pin. Otherwise may be left unconnected
IOCTRL(A)	Highdrive input	This pin provides fast RESET, SET, CLOCK, and ENABLE access to the I/O cell flip-flops, providing fast clock-to-out and fast I/O response times. This pin can also double as a high-drive pin to the internal logic cells. The A inside the parenthesis means that IOCTRL is located in Bank A. This pin should be tied to GND or V <sub>CC</sub> if it is not used.

## Recommended Unused Pin Terminations for the EclipsePlus devices

All unused, general purpose I/O pins can be tied to  $V_{CC}$ , GND, or HIZ (high impedance) internally using the Configuration Editor. This option is given in the bottom-right corner of the placement window. To use the Placement Editor, choose **Constraint > Fix Placement** in the Option pull-down menu of SpDE.

The rest of the pins should be terminated at the board level in the manner presented in **Table 21**.

Table 21: Recommended Unused Pin Terminations

Signal Name	Recommended Termination
PLLOUT<x> <sup>a</sup>	Unused PLL output pins must be connected to either $V_{CC}$ or GND so that their associated input buffer never floats. Utilized PLL output pins that route the PLL clock outside of the chip should not be tied to either $V_{CC}$ or GND.
IOCTRL<y> <sup>b</sup>	Any unused pins of this type must be connected to either $V_{CC}$ or GND.
CLK/PLLIN<x>	Any unused clock pins should be connected to $V_{CC}$ or GND.
PLL_RST<x>	If a PLL module is not used, then the associated PLL_RST<x> must be connected to $V_{CC}$ . Under normal operation use it as needed.
INREF<y>	If an I/O bank does not require the use of INREF signal the pin should be connected to GND.

a. x represents a number

b. y represents an alphabetical character

## 280 PBGA Pinout Diagram

### Top

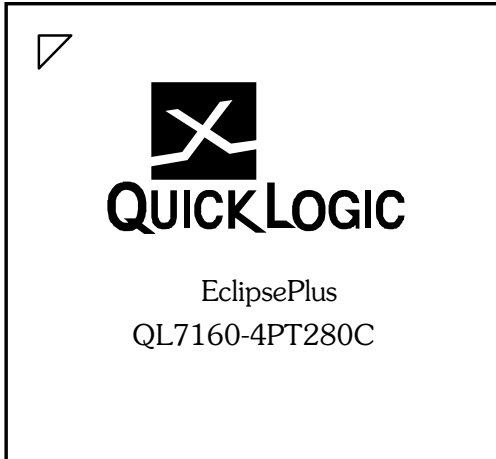

### Bottom

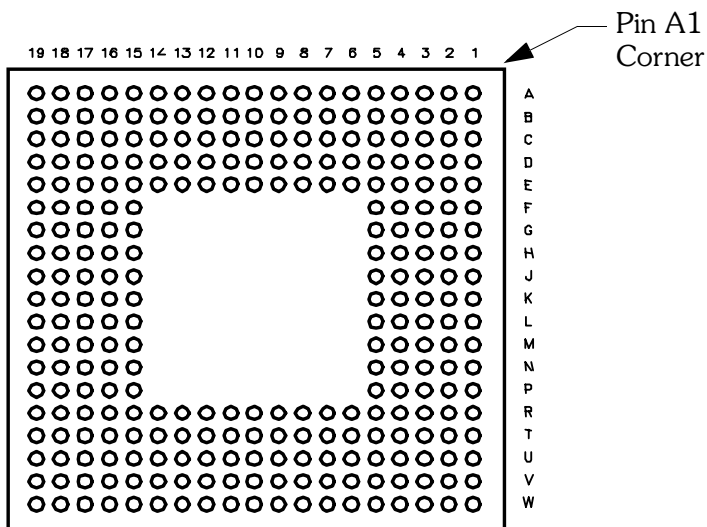

## 280 PBGA Pinout Table

Table 22: 280 PBGA Pinout Table

PBGA	Function	PBGA	Function	PBGA	Function	PBGA	Function	PBGA	Function	PBGA	Function
A1	PLLOUT<3>	C10	CLK<5>/PLLI N<3>	E19	IOCTRL<D>	K16	I/O<C>	R4	I/O<H>	U13	I/O<B>
A2	GNDPLL<0>	C11	V <sub>CCIO</sub> <E>	F1	INREF<G>	K17	I/O<D>	R5	GND	U14	IOCTRL<B>
A3	I/O<F>	C12	I/O<E>	F2	IOCTRL<G>	K18	I/O<C>	R6	GND	U15	V <sub>CCIO</sub> <B>
A4	I/O<F>	C13	I/O<E>	F3	I/O<G>	K19	TRSTB	R7	V <sub>CC</sub>	U16	I/O<B>
A5	I/O<F>	C14	I/O<E>	F4	I/O<G>	L1	I/O<H>	R8	V <sub>CC</sub>	U17	TDO
A6	IOCTRL<F>	C15	V <sub>CCIO</sub> <E>	F5	GND	L2	I/O<H>	R9	GND	U18	PLLRST<2>
A7	I/O<F>	C16	I/O<E>	F15	V <sub>CC</sub>	L3	V <sub>CCIO</sub> <H>	R10	GND	U19	I/O<B>
A8	I/O<F>	C17	I/O<E>	F16	IOCTRL<D>	L4	I/O<H>	R11	V <sub>CC</sub>	V1	PLLOUT<2>
A9	I/O<F>	C18	I/O<E>	F17	I/O<D>	L5	V <sub>CC</sub>	R12	V <sub>CC</sub>	V2	GNDPLL<3>
A10	CLK<7>	C19	I/O<E>	F18	I/O<D>	L15	GND	R13	V <sub>CC</sub>	V3	GND
A11	I/O<E>	D1	I/O<G>	F19	I/O<D>	L16	I/O<C>	R14	V <sub>CC</sub>	V4	I/O<A>
A12	I/O<E>	D2	I/O<G>	G1	I/O<G>	L17	V <sub>CCIO</sub> <C>	R15	GND	V5	I/O<A>
A13	I/O<E>	D3	I/O<F>	G2	I/O<G>	L18	I/O<C>	R16	I/O<C>	V6	IOCTRL<A>
A14	IOCTRL<E>	D4	I/O<F>	G3	IOCTRL<G>	L19	I/O<C>	R17	V <sub>CCIO</sub> <C>	V7	I/O<A>
A15	I/O<E>	D5	I/O<F>	G4	I/O<G>	M1	I/O<H>	R18	I/O<C>	V8	I/O<A>
A16	I/O<E>	D6	I/O<F>	G5	V <sub>CC</sub>	M2	I/O<H>	R19	I/O<C>	V9	I/O<A>
A17	I/O<E>	D7	I/O<F>	G15	V <sub>CC</sub>	M3	I/O<H>	T1	I/O<H>	V10	CLK<1>
A18	PLLRST<1>	D8	I/O<F>	G16	I/O<D>	M4	I/O<H>	T2	I/O<H>	V11	CLK<4>/DEDC LK/PLLI<0>
A19	GND	D9	CLK<8>	G17	I/O<D>	M5	V <sub>CC</sub>	T3	I/O<A>	V12	I/O<B>
B1	PLLRST<0>	D10	I/O<E>	G18	I/O<D>	M15	V <sub>CC</sub>	T4	I/O<A>	V13	I/O<B>
B2	GND	D11	I/O<E>	G19	I/O<D>	M16	INREF<C>	T5	I/O<A>	V14	INREF<B>
B3	I/O<F>	D12	I/O<E>	H1	I/O<G>	M17	I/O<C>	T6	IOCTRL<A>	V15	I/O<B>
B4	I/O<F>	D13	INREF<E>	H2	I/O<G>	M18	I/O<C>	T7	I/O<A>	V16	I/O<B>
B5	I/O<F>	D14	I/O<E>	H3	I/O<G>	M19	I/O<C>	T8	I/O<A>	V17	I/O<B>
B6	INREF<F>	D15	I/O<E>	H4	I/O<G>	N1	IOCTRL<H>	T9	I/O<A>	V18	GNDPLL<2>
B7	I/O<F>	D16	I/O<D>	H5	V <sub>CC</sub>	N2	I/O<H>	T10	I/O<A>	V19	GND
B8	I/O<F>	D17	I/O<D>	H15	V <sub>CC</sub>	N3	I/O<H>	T11	CLK<3>/PLLI N<1>	W1	GND
B9	TMS	D18	I/O<D>	H16	V <sub>CC</sub>	N4	I/O<H>	T12	I/O<B>	W2	PLLRST<3>
B10	CLK<6>	D19	I/O<D>	H17	I/O<D>	N5	V <sub>CC</sub>	T13	I/O<B>	W3	I/O<A>
B11	I/O<E>	E1	I/O<G>	H18	I/O<D>	N15	V <sub>CC</sub>	T14	I/O<B>	W4	I/O<A>
B12	I/O<E>	E2	I/O<G>	H19	I/O<D>	N16	I/O<C>	T15	I/O<B>	W5	I/O<A>
B13	IOCTRL<E>	E3	V <sub>CCIO</sub> <G>	J1	I/O<G>	N17	I/O<C>	T16	I/O<B>	W6	I/O<A>
B14	I/O<E>	E4	I/O<F>	J2	I/O<G>	N18	IOCTRL<C>	T17	V <sub>CCPLL</sub> <2>	W7	I/O<A>
B15	I/O<E>	E5	GND	J3	V <sub>CCIO</sub> <G>	N19	IOCTRL<C>	T18	I/O<B>	W8	I/O<A>
B16	I/O<E>	E6	V <sub>CC</sub>	J4	I/O<G>	P1	I/O<H>	T19	I/O<B>	W9	TDI
B17	V <sub>CCPLL</sub> <1>	E7	V <sub>CC</sub>	J5	GND	P2	I/O<H>	U1	I/O<A>	W10	CLK<2>/PLLI N<2>
B18	GNDPLL<1>	E8	V <sub>CC</sub>	J15	V <sub>CC</sub>	P3	IOCTRL<H>	U2	I/O<A>	W11	I/O<B>
B19	PLLOUT<0>	E9	V <sub>CC</sub>	J16	I/O<C>	P4	INREF<H>	U3	V <sub>CCPLL</sub> <3>	W12	I/O<B>
C1	I/O<F>	E10	GND	J17	V <sub>CCIO</sub> <D>	P5	V <sub>CC</sub>	U4	I/O<A>	W13	I/O<B>
C2	V <sub>CCPLL</sub> <0>	E11	GND	J18	I/O<D>	P15	GND	U5	V <sub>CCIO</sub> <A>	W14	IOCTRL<B>
C3	I/O<F>	E12	V <sub>CC</sub>	J19	I/O<D>	P16	I/O<C>	U6	INREF<A>	W15	I/O<B>
C4	I/O<F>	E13	V <sub>CC</sub>	K1	V <sub>CC</sub>	P17	I/O<C>	U7	I/O<A>	W16	I/O<B>
C5	V <sub>CCIO</sub> <F>	E14	GND	K2	TCK	P18	I/O<C>	U8	I/O<A>	W17	I/O<B>
C6	IOCTRL<F>	E15	GND	K3	I/O<G>	P19	I/O<C>	U9	V <sub>CCIO</sub> <A>	W18	I/O<B>
C7	I/O<F>	E16	I/O<D>	K4	I/O<G>	R1	I/O<H>	U10	CLK<0>	W19	PLLOUT<1>
C8	I/O<F>	E17	V <sub>CCIO</sub> <D>	K5	GND	R2	I/O<H>	U11	V <sub>CCIO</sub> <B>		
C9	V <sub>CCIO</sub> <F>	E18	INREF<D>	K15	GND	R3	V <sub>CCIO</sub> <H>	U12	I/O<B>		

# 280 PBGA Packaging Drawing

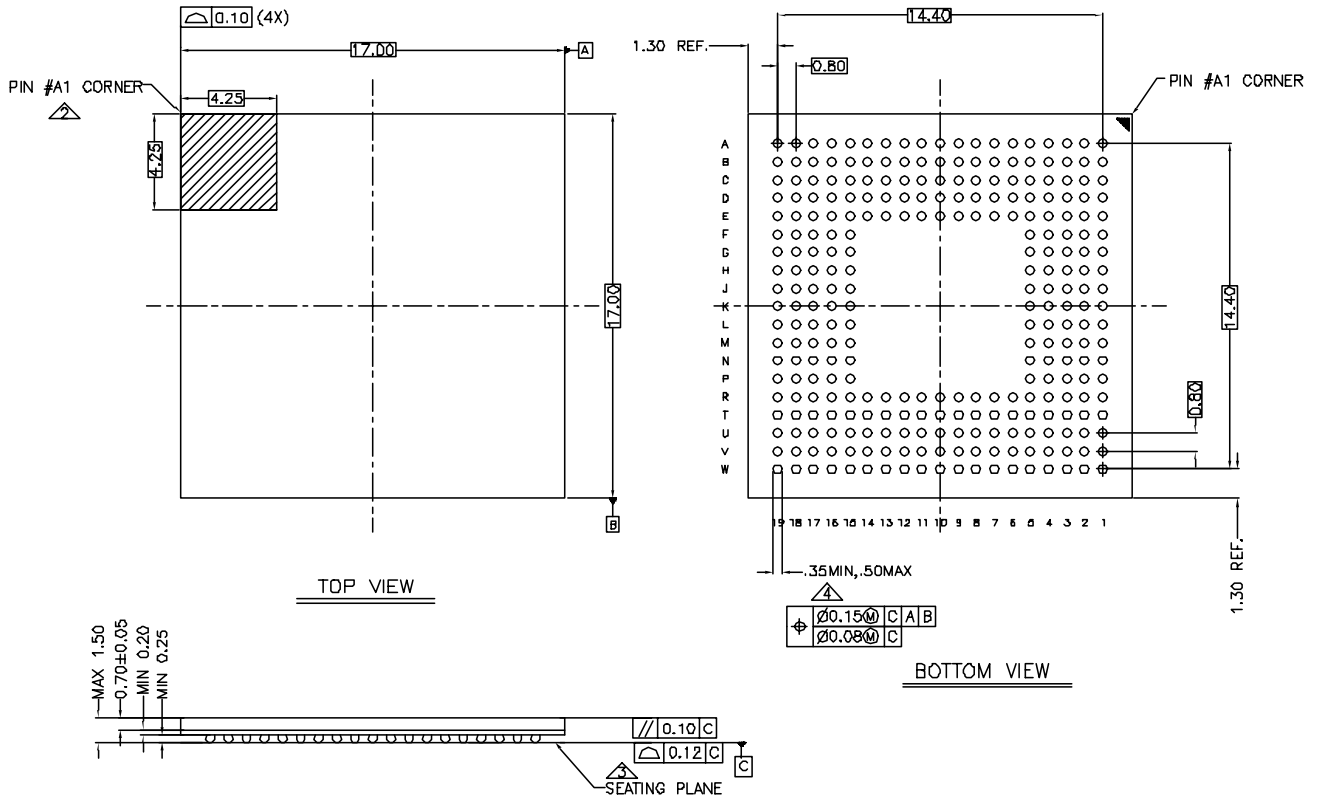

Figure 28: 280 PBGA Packaging Drawing

## 484 PBGA Pinout Diagram

Top



Bottom

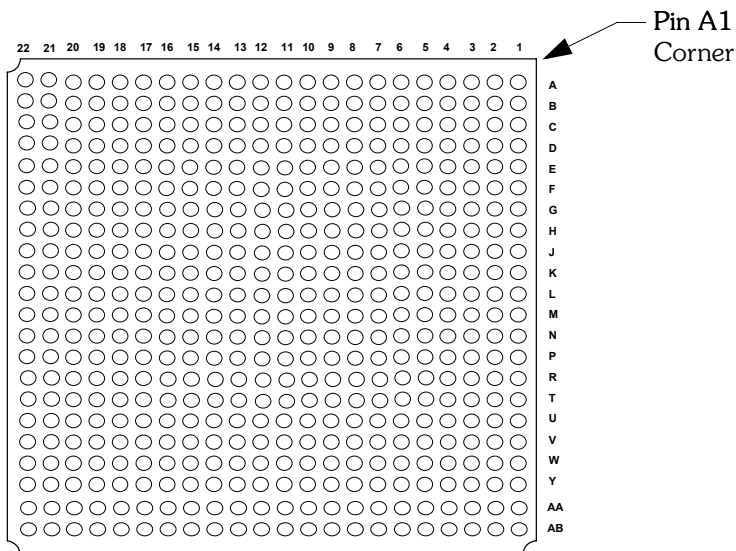



# 484 PBGA Pinout Table

Table 23: 484 PBGA Pinout Table

PBGA	Function	PBGA	Function	PBGA	Function	PBGA	Function	PBGA	Function	PBGA	Function
A1	I/O<A>	C1	I/O<A>	E1	IOCTRL<A>	G1	I/O<A>	J1	I/O<A>	L1	CLK<4>/DEDCLK/P LLIN<0>
A2	PLLIRST<3>	C2	I/O<A>	E2	I/O<A>	G2	I/O<A>	J2	I/O<A>	L2	CLK<0>
A3	I/O<A>	C3	V <sub>CCPLL</sub> <3>	E3	I/O<A>	G3	I/O<A>	J3	I/O<A>	L3	CLK<2>/PLLIN<2>
A4	I/O<A>	C4	PLLOUT<2>	E4	I/O<A>	G4	I/O<A>	J4	I/O<A>	L4	I/O<A>
A5	I/O<A>	C5	I/O<A>	E5	I/O<A>	G5	I/O<A>	J5	I/O<A>	L5	I/O<A>
A6	I/O<H>	C6	I/O<H>	E6	I/O<H>	G6	I/O<A>	J6	I/O<A>	L6	I/O<A>
A7	I/O<H>	C7	I/O<H>	E7	I/O<H>	G7	GND	J7	I/O<A>	L7	GND
A8	IOCTRL<H>	C8	I/O<H>	E8	I/O<H>	G8	I/O<H>	J8	V <sub>CC</sub>	L8	GND
A9	I/O<H>	C9	IOCTRL<H>	E9	I/O<H>	G9	I/O<H>	J9	GND	L9	GND
A10	I/O<H>	C10	I/O<H>	E10	I/O<H>	G10	I/O<H>	J10	V <sub>CC</sub>	L10	GND
A11	I/O<H>	C11	I/O<H>	E11	V <sub>CC</sub>	G11	I/O<G>	J11	V <sub>CC</sub>	L11	GND
A12	TCK	C12	I/O<H>	E12	I/O<G>	G12	GND	J12	GND	L12	GND
A13	I/O<G>	C13	I/O<G>	E13	I/O<G>	G13	I/O<G>	J13	V <sub>CC</sub>	L13	GND
A14	I/O<G>	C14	I/O<G>	E14	I/O<G>	G14	I/O<G>	J14	GND	L14	V <sub>CC</sub>
A15	I/O<G>	C15	I/O<G>	E15	IOCTRL<G>	G15	I/O<G>	J15	V <sub>CC</sub>	L15	V <sub>CC</sub>
A16	I/O<G>	C16	I/O<G>	E16	I/O<G>	G16	GND	J16	I/O<F>	L16	CLK<6>
A17	I/O<G>	C17	I/O<G>	E17	INREF<G>	G17	V <sub>CCIO</sub> <F>	J17	V <sub>CCIO</sub> <F>	L17	V <sub>CCIO</sub> <F>
A18	I/O<G>	C18	I/O<G>	E18	I/O<G>	G18	I/O<F>	J18	I/O<F>	L18	I/O<F>
A19	I/O<F>	C19	I/O<F>	E19	I/O<F>	G19	I/O<F>	J19	I/O<F>	L19	CLK<8>
A20	GND	C20	GNDPLL<0>	E20	I/O<F>	G20	I/O<F>	J20	I/O<F>	L20	I/O<F>
A21	PLLOUT<3>	C21	I/O<F>	E21	I/O<F>	G21	INREF<F>	J21	I/O<F>	L21	I/O<F>
A22	I/O<F>	C22	I/O<F>	E22	I/O<F>	G22	I/O<F>	J22	I/O<F>	L22	I/O<F>
B1	I/O<A>	D1	I/O<A>	F1	I/O<A>	H1	I/O<A>	K1	TDI	M1	I/O<B>
B2	GND	D2	I/O<A>	F2	INREF<A>	H2	I/O<A>	K2	I/O<A>	M2	I/O<B>
B3	GNDPLL<3>	D3	I/O<A>	F3	I/O<A>	H3	I/O<A>	K3	I/O<A>	M3	I/O<B>
B4	GND	D4	I/O<A>	F4	I/O<A>	H4	I/O<A>	K4	I/O<A>	M4	CLK<3>/PLLIN<1>
B5	I/O<A>	D5	I/O<A>	F5	I/O<A>	H5	IOCTRL<A>	K5	I/O<A>	M5	I/O<B>
B6	I/O<H>	D6	I/O<H>	F6	V <sub>CCIO</sub> <A>	H6	V <sub>CCIO</sub> <A>	K6	V <sub>CCIO</sub> <A>	M6	V <sub>CCIO</sub> <B>
B7	I/O<H>	D7	I/O<H>	F7	V <sub>CCIO</sub> <H>	H7	I/O<H>	K7	I/O<A>	M7	CLK<1>
B8	INREF<H>	D8	I/O<H>	F8	I/O<H>	H8	GND	K8	V <sub>CC</sub>	M8	V <sub>CC</sub>
B9	I/O<H>	D9	I/O<H>	F9	V <sub>CCIO</sub> <H>	H9	V <sub>CC</sub>	K9	V <sub>CC</sub>	M9	V <sub>CC</sub>
B10	I/O<H>	D10	I/O<H>	F10	I/O<H>	H10	V <sub>CC</sub>	K10	GND	M10	GND
B11	I/O<H>	D11	I/O<H>	F11	V <sub>CCIO</sub> <H>	H11	V <sub>CC</sub>	K11	GND	M11	GND
B12	I/O<G>	D12	I/O<G>	F12	V <sub>CCIO</sub> <G>	H12	GND	K12	GND	M12	GND
B13	I/O<G>	D13	I/O<G>	F13	I/O<G>	H13	V <sub>CC</sub>	K13	GND	M13	GND
B14	I/O<G>	D14	I/O<G>	F14	V <sub>CCIO</sub> <G>	H14	V <sub>CC</sub>	K14	V <sub>CC</sub>	M14	GND
B15	I/O<G>	D15	IOCTRL<G>	F15	I/O<G>	H15	GND	K15	V <sub>CC</sub>	M15	GND
B16	I/O<G>	D16	I/O<G>	F16	V <sub>CCIO</sub> <G>	H16	I/O<F>	K16	I/O<F>	M16	GND
B17	I/O<G>	D17	I/O<G>	F17	I/O<G>	H17	I/O<F>	K17	I/O<F>	M17	I/O<E>
B18	I/O<G>	D18	I/O<F>	F18	I/O<F>	H18	I/O<F>	K18	I/O<F>	M18	I/O<E>
B19	PLLIRST<0>	D19	V <sub>CCPLL</sub> <0>	F19	I/O<F>	H19	I/O<F>	K19	I/O<F>	M19	I/O<E>
B20	I/O<F>	D20	I/O<F>	F20	IOCTRL<F>	H20	I/O<F>	K20	I/O<F>	M20	CLK<7>
B21	I/O<F>	D21	I/O<F>	F21	I/O<F>	H21	I/O<F>	K21	I/O<F>	M21	CLK<5>/PLLIN<3>
B22	I/O<F>	D22	I/O<F>	F22	IOCTRL<F>	H22	I/O<F>	K22	I/O<F>	M22	TMS

(Sheet 1 of 2)

Table 23: 484 PBGA Pinout Table (Continued)

PBGA	Function	PBGA	Function	PBGA	Function	PBGA	Function	PBGA	Function	PBGA	Function
N1	I/O<B>	P16	I/O<E>	T9	I/O<C>	V2	I/O<B>	W17	I/O<D>	AA10	I/O<C>
N2	I/O<B>	P17	I/O<E>	T10	TRSTB	V3	I/O<B>	W18	I/O<E>	AA11	I/O<C>
N3	I/O<B>	P18	I/O<E>	T11	GND	V4	I/O<B>	W19	I/O<E>	AA12	I/O<D>
N4	I/O<B>	P19	I/O<E>	T12	I/O<C>	V5	I/O<B>	W20	I/O<E>	AA13	I/O<D>
N5	I/O<B>	P20	I/O<E>	T13	I/O<D>	V6	I/O<C>	W21	I/O<E>	AA14	I/O<D>
N6	I/O<B>	P21	I/O<E>	T14	I/O<D>	V7	I/O<C>	W22	I/O<E>	AA15	I/O<D>
N7	I/O<B>	P22	I/O<E>	T15	I/O<D>	V8	I/O<C>	Y1	I/O<B>	AA16	I/O<D>
N8	V <sub>CC</sub>	R1	I/O<B>	T16	GND	V9	I/O<C>	Y2	I/O<B>	AA17	I/O<D>
N9	V <sub>CC</sub>	R2	INREF<B>	T17	I/O<E>	V10	I/O<C>	Y3	V <sub>CCPLL&lt;2&gt;</sub>	AA18	I/O<D>
N10	GND	R3	I/O<B>	T18	I/O<E>	V11	I/O<C>	Y4	I/O<C>	AA19	I/O<E>
N11	GND	R4	I/O<B>	T19	I/O<E>	V12	V <sub>CC</sub>	Y5	I/O<C>	AA20	GNDPLL<1>
N12	GND	R5	I/O<B>	T20	I/O<E>	V13	I/O<D>	Y6	I/O<C>	AA21	I/O<E>
N13	GND	R6	I/O<B>	T21	IOCTRL<E>	V14	I/O<D>	Y7	I/O<C>	AA22	I/O<E>
N14	V <sub>CC</sub>	R7	I/O<B>	T22	I/O<E>	V15	I/O<D>	Y8	IOCTRL<C>	AB1	I/O<B>
N15	V <sub>CC</sub>	R8	GND	U1	IOCTRL<B>	V16	INREF<D>	Y9	I/O<C>	AB2	GNDPLL<2>
N16	I/O<E>	R9	V <sub>CC</sub>	U2	I/O<B>	V17	I/O<D>	Y10	I/O<C>	AB3	PLL <sub>RST&lt;2&gt;</sub>
N17	V <sub>CCIO&lt;E&gt;</sub>	R10	V <sub>CC</sub>	U3	IOCTRL<B>	V18	I/O<E>	Y11	I/O<D>	AB4	I/O<B>
N18	I/O<E>	R11	GND	U4	I/O<B>	V19	I/O<E>	Y12	I/O<D>	AB5	I/O<B>
N19	I/O<E>	R12	V <sub>CC</sub>	U5	I/O<B>	V20	I/O<E>	Y13	I/O<D>	AB6	I/O<C>
N20	I/O<E>	R13	V <sub>CC</sub>	U6	I/O<C>	V21	I/O<E>	Y14	I/O<D>	AB7	I/O<C>
N21	I/O<E>	R14	V <sub>CC</sub>	U7	V <sub>CCIO&lt;C&gt;</sub>	V22	I/O<E>	Y15	IOCTRL<D>	AB8	IOCTRL<C>
N22	I/O<E>	R15	GND	U8	I/O<C>	W1	I/O<B>	Y16	I/O<D>	AB9	I/O<C>
P1	I/O<B>	R16	I/O<D>	U9	V <sub>CCIO&lt;C&gt;</sub>	W2	I/O<B>	Y17	I/O<D>	AB10	I/O<C>
P2	I/O<B>	R17	V <sub>CCIO&lt;E&gt;</sub>	U10	I/O<C>	W3	I/O<B>	Y18	I/O<E>	AB11	I/O<C>
P3	I/O<B>	R18	I/O<E>	U11	V <sub>CCIO&lt;C&gt;</sub>	W4	I/O<B>	Y19	PLLOUT<0>	AB12	I/O<D>
P4	I/O<B>	R19	I/O<E>	U12	V <sub>CCIO&lt;D&gt;</sub>	W5	I/O<B>	Y20	PLL <sub>RST&lt;1&gt;</sub>	AB13	I/O<D>
P5	I/O<B>	R20	I/O<E>	U13	I/O<D>	W6	I/O<C>	Y21	I/O<E>	AB14	I/O<D>
P6	V <sub>CCIO&lt;B&gt;</sub>	R21	I/O<E>	U14	V <sub>CCIO&lt;D&gt;</sub>	W7	I/O<C>	Y22	I/O<E>	AB15	I/O<D>
P7	I/O<B>	R22	I/O<E>	U15	I/O<D>	W8	I/O<C>	AA1	TDO	AB16	IOCTRL<D>
P8	V <sub>CC</sub>	T1	I/O<B>	U16	V <sub>CCIO&lt;D&gt;</sub>	W9	I/O<C>	AA2	PLLOUT<1>	AB17	I/O<D>
P9	GND	T2	I/O<B>	U17	V <sub>CCIO&lt;E&gt;</sub>	W10	I/O<C>	AA3	GND	AB18	I/O<D>
P10	V <sub>CC</sub>	T3	I/O<B>	U18	I/O<E>	W11	I/O<C>	AA4	I/O<B>	AB19	I/O<E>
P11	GND	T4	I/O<B>	U19	I/O<E>	W12	I/O<D>	AA5	I/O<C>	AB20	GND
P12	V <sub>CC</sub>	T5	I/O<B>	U20	IOCTRL<E>	W13	I/O<D>	AA6	I/O<C>	AB21	V <sub>CCPLL&lt;1&gt;</sub>
P13	V <sub>CC</sub>	T6	V <sub>CCIO&lt;B&gt;</sub>	U21	I/O<E>	W14	I/O<D>	AA7	I/O<C>	AB22	I/O<E>
P14	GND	T7	GND	U22	INREF<E>	W15	I/O<D>	AA8	INREF<C>		
P15	V <sub>CC</sub>	T8	I/O<C>	V1	I/O<B>	W16	I/O<D>	AA9	I/O<C>		

(Sheet 2 of 2)

# 484 PBGA Packaging Drawing

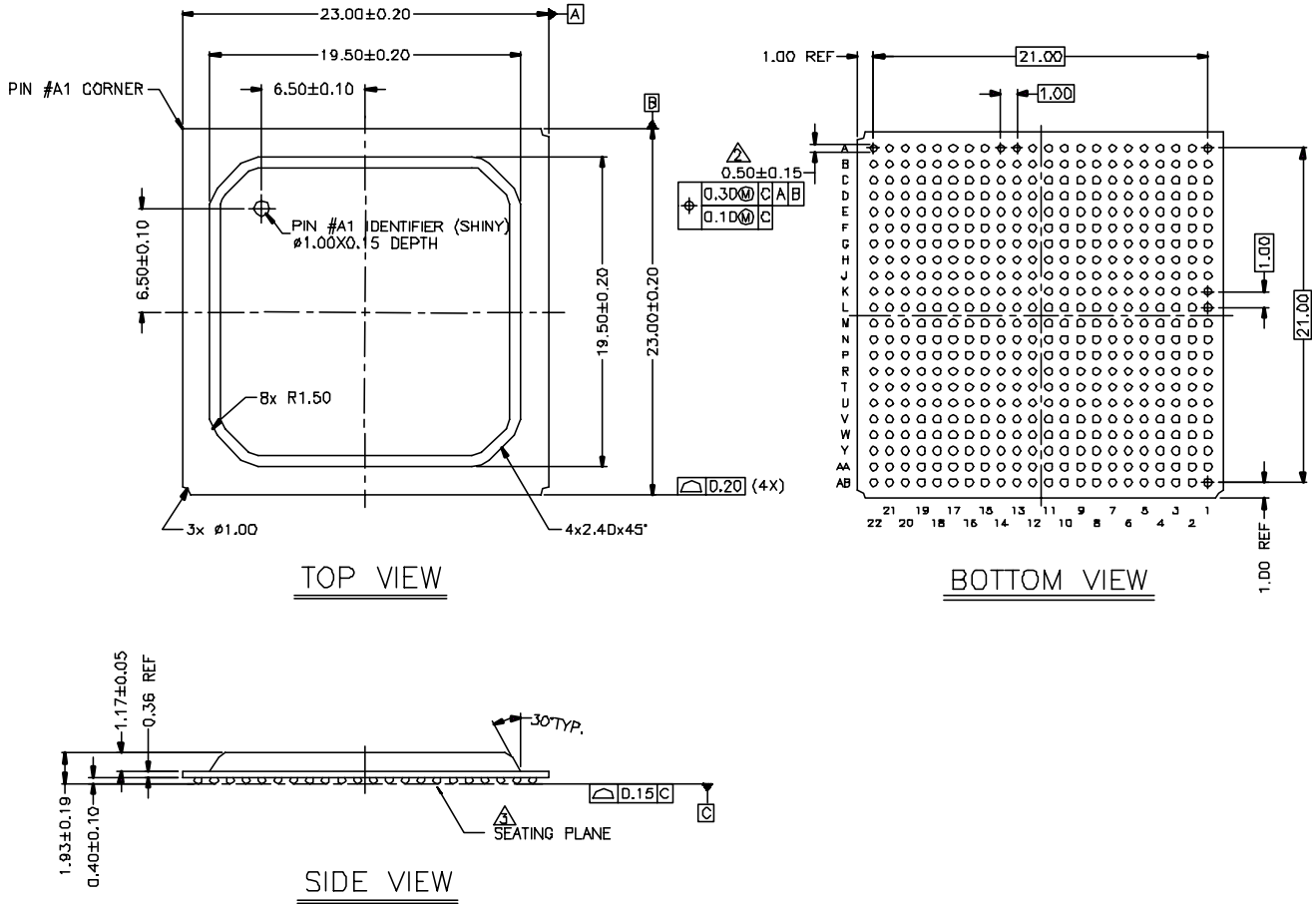

Figure 29: 484 PBGA Packaging Drawing

# 516 PBGA Pinout Diagram

## Top



## Bottom

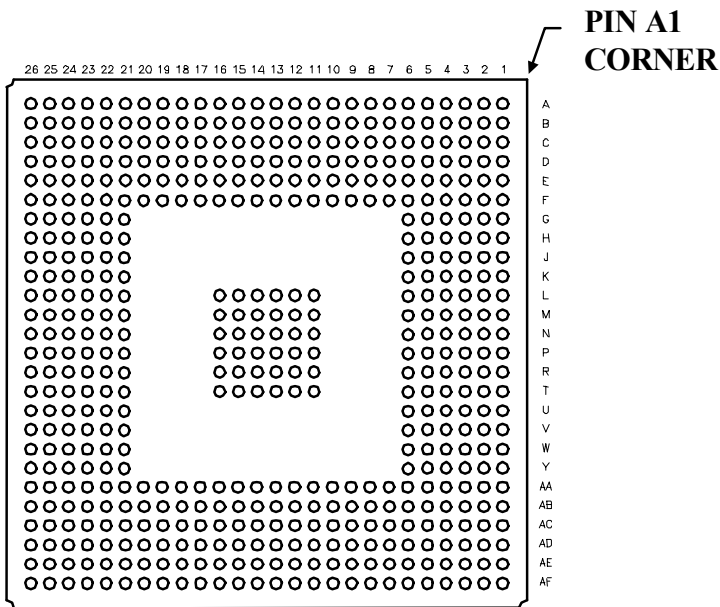

# 516 PBGA Pinout Table

Table 24: 516 PBGA Pinout Table

PBGA	Function	PBGA	Function	PBGA	Function	PBGA	Function	PBGA	Function	PBGA	Function
A1	GND	C1	I/O<F>	E1	I/O<G>	G1	I/O<G>	L5	V <sub>CC</sub>	P3	I/O<H>
A2	I/O<F>	C2	I/O<F>	E2	I/O<G>	G2	INREF<G>	L6	V <sub>CC</sub>	P4	V <sub>CC</sub>
A3	I/O<F>	C3	I/O<F>	E3	I/O<G>	G3	I/O<G>	L11	GND	P5	I/O<H>
A4	I/O<F>	C4	PLLOUT<3>	E4	V <sub>CCPLL&lt;0&gt;</sub>	G4	I/O<G>	L12	GND	P6	V <sub>CCIO&lt;H&gt;</sub>
A5	I/O<F>	C5	I/O<F>	E5	I/O<F>	G5	I/O<G>	L13	GND	P11	GND
A6	I/O<F>	C6	I/O<F>	E6	I/O<F>	G6	V <sub>CCIO&lt;G&gt;</sub>	L14	GND	P12	GND
A7	IOCTRL<F>	C7	I/O<F>	E7	I/O<F>	G21	V <sub>CCIO&lt;D&gt;</sub>	L15	GND	P13	GND
A8	I/O<F>	C8	INREF<F>	E8	V <sub>CC</sub>	G22	I/O<D>	L16	GND	P14	GND
A9	I/O<F>	C9	I/O<F>	E9	I/O<F>	G23	I/O<D>	L21	V <sub>CC</sub>	P15	GND
A10	I/O<F>	C10	I/O<F>	E10	I/O<F>	G24	I/O<D>	L22	I/O<D>	P16	GND
A11	I/O<F>	C11	I/O<F>	E11	I/O<F>	G25	I/O<D>	L23	I/O<D>	P21	V <sub>CCIO&lt;C&gt;</sub>
A12	I/O<F>	C12	I/O<F>	E12	V <sub>CC</sub>	G26	INREF<D>	L24	I/O<D>	P22	I/O<C>
A13	I/O<E>	C13	CLK<7>	E13	I/O<F>	H1	I/O<G>	L25	I/O<D>	P23	V <sub>CC</sub>
A14	I/O<E>	C14	I/O<E>	E14	I/O<F>	H2	I/O<G>	L26	I/O<D>	P24	I/O<C>
A15	I/O<E>	C15	I/O<E>	E15	I/O<E>	H3	IOCTRL<G>	M1	I/O<G>	P25	I/O<C>
A16	I/O<E>	C16	I/O<E>	E16	V <sub>CC</sub>	H4	I/O<G>	M2	I/O<G>	P26	TRSTB
A17	I/O<E>	C17	I/O<E>	E17	CLK<6>	H5	I/O<G>	M3	I/O<G>	R1	I/O<H>
A18	IOCTRL<E>	C18	I/O<E>	E18	I/O<E>	H6	V <sub>CC</sub>	M4	I/O<G>	R2	I/O<H>
A19	IOCTRL<E>	C19	I/O<E>	E19	I/O<E>	H21	V <sub>CC</sub>	M5	I/O<G>	R3	I/O<H>
A20	I/O<E>	C20	I/O<E>	E20	I/O<E>	H22	V <sub>CC</sub>	M6	V <sub>CCIO&lt;G&gt;</sub>	R4	I/O<H>
A21	I/O<E>	C21	I/O<E>	E21	I/O<E>	H23	I/O<D>	M11	GND	R5	V <sub>CC</sub>
A22	I/O<E>	C22	I/O<E>	E22	I/O<E>	H24	IOCTRL<D>	M12	GND	R6	V <sub>CC</sub>
A23	I/O<E>	C23	I/O<E>	E23	GNDPLL<1>	H25	IOCTRL<D>	M13	GND	R11	GND
A24	I/O<E>	C24	I/O<E>	E24	I/O<E>	H26	I/O<D>	M14	GND	R12	GND
A25	PLLST<1>	C25	I/O<E>	E25	I/O<D>	J1	I/O<G>	M15	GND	R13	GND
A26	GND	C26	I/O<E>	E26	I/O<D>	J2	I/O<G>	M16	GND	R14	GND
B1	I/O<F>	D1	I/O<G>	F1	IOCTRL<G>	J3	I/O<G>	M21	V <sub>CCIO&lt;D&gt;</sub>	R15	GND
B2	PLLST<0>	D2	I/O<G>	F2	I/O<G>	J4	I/O<G>	M22	V <sub>CC</sub>	R16	GND
B3	I/O<F>	D3	I/O<F>	F3	I/O<G>	J5	I/O<G>	M23	I/O<D>	R21	V <sub>CC</sub>
B4	I/O<F>	D4	I/O<F>	F4	I/O<G>	J6	V <sub>CCIO&lt;G&gt;</sub>	M24	I/O<D>	R22	I/O<C>
B5	I/O<F>	D5	GNDPLL<0>	F5	I/O<F>	J21	V <sub>CCIO&lt;D&gt;</sub>	M25	I/O<D>	R23	I/O<C>
B6	I/O<F>	D6	I/O<F>	F6	GND	J22	I/O<D>	M26	I/O<D>	R24	I/O<C>
B7	IOCTRL<F>	D7	I/O<F>	F7	V <sub>CCIO&lt;F&gt;</sub>	J23	I/O<D>	N1	TCK	R25	I/O<C>
B8	I/O<F>	D8	I/O<F>	F8	V <sub>CC</sub>	J24	I/O<D>	N2	I/O<H>	R26	I/O<C>
B9	I/O<F>	D9	I/O<F>	F9	V <sub>CCIO&lt;F&gt;</sub>	J25	I/O<D>	N3	I/O<G>	T1	I/O<H>
B10	I/O<F>	D10	I/O<F>	F10	GND	J26	I/O<D>	N4	I/O<G>	T2	I/O<H>
B11	I/O<F>	D11	I/O<F>	F11	V <sub>CC</sub>	K1	I/O<G>	N5	I/O<G>	T3	I/O<H>
B12	I/O<F>	D12	I/O<F>	F12	V <sub>CCIO&lt;F&gt;</sub>	K2	I/O<G>	N6	GND	T4	I/O<H>
B13	CLK<5>/PL LIN<3>	D13	TMS	F13	GND	K3	I/O<G>	N11	GND	T5	I/O<H>
B14	I/O<E>	D14	I/O<E>	F14	V <sub>CCIO&lt;E&gt;</sub>	K4	I/O<G>	N12	GND	T6	V <sub>CC</sub>
B15	I/O<E>	D15	I/O<E>	F15	V <sub>CC</sub>	K5	I/O<G>	N13	GND	T11	GND
B16	I/O<E>	D16	I/O<F>	F16	V <sub>CC</sub>	K6	GND	N14	GND	T12	GND
B17	I/O<E>	D17	I/O<E>	F17	GND	K21	GND	N15	GND	T13	GND
B18	INREF<E>	D18	I/O<F>	F18	V <sub>CCIO&lt;E&gt;</sub>	K22	I/O<D>	N16	GND	T14	GND
B19	I/O<E>	D19	CLK<8>	F19	V <sub>CC</sub>	K23	I/O<D>	N21	GND	T15	GND
B20	I/O<E>	D20	I/O<E>	F20	V <sub>CCIO&lt;E&gt;</sub>	K24	I/O<D>	N22	I/O<D>	T16	GND
B21	I/O<E>	D21	I/O<E>	F21	GND	K25	I/O<D>	N23	I/O<D>	T21	V <sub>CC</sub>
B22	I/O<E>	D22	I/O<E>	F22	I/O<E>	K26	I/O<D>	N24	I/O<D>	T22	V <sub>CC</sub>
B23	I/O<E>	D23	V <sub>CCPLL&lt;1&gt;</sub>	F23	I/O<D>	L1	I/O<G>	N25	I/O<D>	T23	I/O<C>
B24	I/O<E>	D24	I/O<E>	F24	I/O<D>	L2	I/O<G>	N26	I/O<D>	T24	I/O<C>
B25	I/O<E>	D25	I/O<E>	F25	I/O<D>	L3	I/O<G>	P1	I/O<H>	T25	I/O<C>
B26	PLLOUT<0>	D26	I/O<D>	F26	I/O<D>	L4	I/O<G>	P2	I/O<H>	T26	I/O<C>

(Sheet 1 of 2)

Table 24: 516 PBGA Pinout Table (Continued)

PBGA	Function	PBGA	Function	PBGA	Function	PBGA	Function	PBGA	Function	PBGA	Function
U1	I/O<H>	W25	INREF<C>	AA21	GND	AC3	I/O<A>	AD11	I/O<A>	AE19	I/O<B>
U2	I/O<H>	W26	I/O<C>	AA22	V <sub>CCPLL</sub> <2>	AC4	I/O<A>	AD12	TDI	AE20	I/O<B>
U3	I/O<H>	Y1	I/O<H>	AA23	I/O<C>	AC5	I/O<A>	AD13	CLK<4> DEDCLK/PLLIN<0>	AE21	I/O<B>
U4	I/O<H>	Y2	I/O<H>	AA24	I/O<C>	AC6	I/O<A>	AD14	I/O<A>	AE22	I/O<B>
U5	I/O<H>	Y3	I/O<H>	AA25	I/O<C>	AC7	I/O<A>	AD15	I/O<B>	AE23	I/O<B>
U6	GND	Y4	I/O<H>	AA26	I/O<C>	AC8	I/O<A>	AD16	I/O<B>	AE24	I/O<B>
U21	GND	Y5	I/O<H>	AB1	I/O<H>	AC9	I/O<A>	AD17	I/O<B>	AE25	PLLRST<2>
U22	I/O<C>	Y6	V <sub>CCIO</sub> <H>	AB2	I/O<H>	AC10	I/O<A>	AD18	INREF<B>	AE26	I/O<B>
U23	I/O<C>	Y21	V <sub>CCIO</sub> <C>	AB3	I/O<A>	AC11	I/O<A>	AD19	I/O<B>	AF1	I/O<A>
U24	I/O<C>	Y22	I/O<C>	AB4	GNDPLL<3>	AC12	I/O<A>	AD20	I/O<B>	AF2	I/O<A>
U25	I/O<C>	Y23	I/O<C>	AB5	V <sub>CCPLL</sub> <3>	AC13	I/O<A>	AD21	I/O<B>	AF3	I/O<A>
U26	I/O<C>	Y24	I/O<C>	AB6	I/O<A>	AC14	CLK<1>	AD22	I/O<B>	AF4	I/O<A>
V1	I/O<H>	Y25	I/O<C>	AB7	I/O<A>	AC15	I/O<B>	AD23	I/O<B>	AF5	I/O<A>
V2	IOCTRL<H>	Y26	IOCTRL<C>	AB8	I/O<A>	AC16	I/O<B>	AD24	GND	AF6	IOCTRL<A>
V3	IOCTRL<H>	AA1	I/O<H>	AB9	I/O<A>	AC17	I/O<B>	AD25	I/O<B>	AF7	I/O<A>
V4	I/O<H>	AA2	I/O<H>	AB10	I/O<A>	AC18	I/O<B>	AD26	I/O<B>	AF8	I/O<A>
V5	I/O<H>	AA3	I/O<H>	AB11	V <sub>CC</sub>	AC19	I/O<B>	AE1	GND	AF9	I/O<A>
V6	V <sub>CCIO</sub> <H>	AA4	I/O<A>	AB12	I/O<A>	AC20	I/O<B>	AE2	GND	AF10	I/O<A>
V21	V <sub>CCIO</sub> <C>	AA5	I/O<A>	AB13	I/O<A>	AC21	I/O<B>	AE3	I/O<A>	AF11	I/O<A>
V22	I/O<C>	AA6	GND	AB14	CLK<3>/PLLIN<1>	AC22	TDO	AE4	I/O<A>	AF12	CLK<2>/PL LIN<2>
V23	I/O<C>	AA7	V <sub>CCIO</sub> <A>	AB15	V <sub>CC</sub>	AC23	PLLOUT<1>	AE5	I/O<A>	AF13	I/O<B>
V24	IOCTRL<C>	AA8	V <sub>CC</sub>	AB16	I/O<B>	AC24	I/O<B>	AE6	I/O<A>	AF14	I/O<B>
V25	I/O<C>	AA9	V <sub>CCIO</sub> <A>	AB17	I/O<B>	AC25	I/O<B>	AE7	INREF<A>	AF15	I/O<B>
V26	I/O<C>	AA10	GND	AB18	I/O<B>	AC26	I/O<C>	AE8	I/O<A>	AF16	I/O<B>
W1	INREF<H>	AA11	V <sub>CC</sub>	AB19	V <sub>CC</sub>	AD1	I/O<A>	AE9	I/O<A>	AF17	I/O<B>
W2	I/O<H>	AA12	V <sub>CCIO</sub> <A>	AB20	I/O<B>	AD2	PLLOUT<2>	AE10	I/O<A>	AF18	I/O<B>
W3	I/O<H>	AA13	GND	AB21	I/O<B>	AD3	PLLRST<3>	AE11	I/O<A>	AF19	IOCTRL<B>
W4	I/O<H>	AA14	V <sub>CCIO</sub> <B>	AB22	GNDPLL<2>	AD4	I/O<A>	AE12	CLK<0>	AF20	IOCTRL<B>
W5	V <sub>CC</sub>	AA15	V <sub>CC</sub>	AB23	I/O<B>	AD5	I/O<A>	AE13	I/O<B>	AF21	I/O<B>
W6	V <sub>CC</sub>	AA16	V <sub>CC</sub>	AB24	I/O<C>	AD6	I/O<A>	AE14	I/O<B>	AF22	I/O<B>
W21	V <sub>CC</sub>	AA17	GND	AB25	I/O<C>	AD7	I/O<A>	AE15	I/O<B>	AF23	I/O<B>
W22	I/O<C>	AA18	V <sub>CCIO</sub> <B>	AB26	I/O<C>	AD8	IOCTRL<A>	AE16	I/O<B>	AF24	I/O<B>
W23	I/O<C>	AA19	V <sub>CC</sub>	AC1	I/O<A>	AD9	I/O<A>	AE17	I/O<B>	AF25	I/O<B>
W24	I/O<C>	AA20	V <sub>CCIO</sub> <B>	AC2	I/O<A>	AD10	I/O<A>	AE18	I/O<B>	AF26	I/O<B>

(Sheet 2 of 2)

# 516 PBGA Packaging Drawing

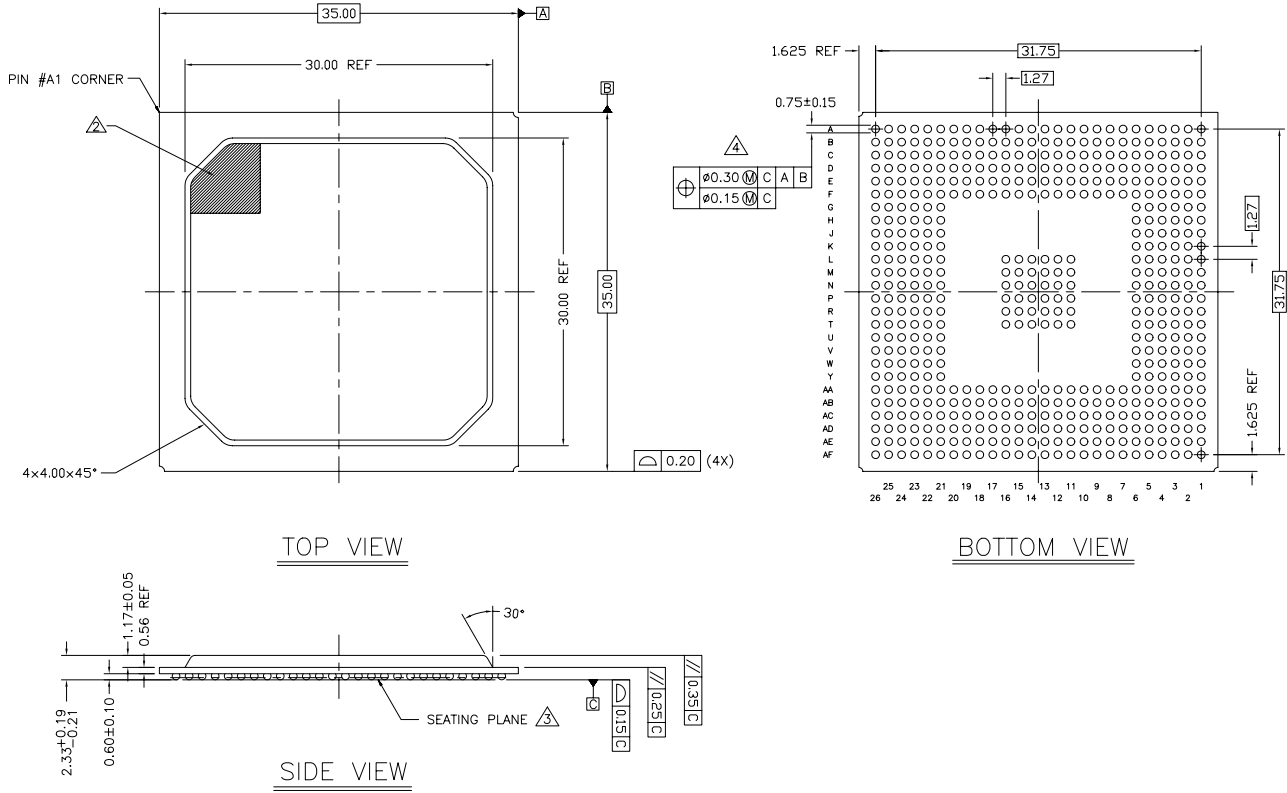
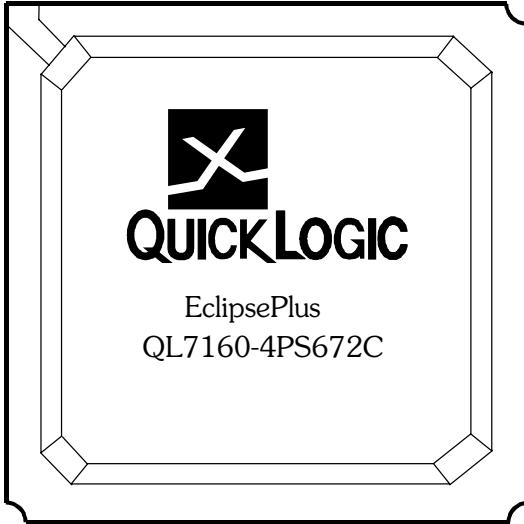

Figure 30: 516 PBGA Packaging Drawing

## 672 PBGA Pinout Diagram

### Top



### Bottom

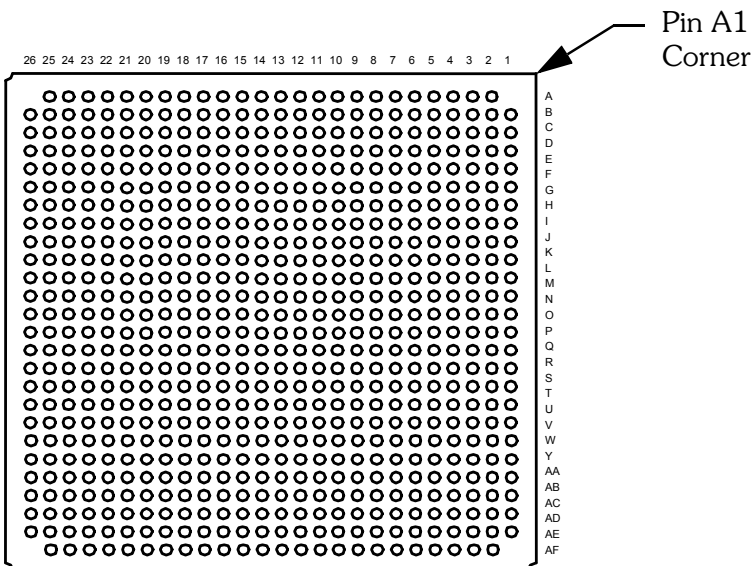



## 672 PBGA Pinout Table

Table 25: 672 PBGA Pinout Table

PBGA	Function	PBGA	Function	PBGA	Function	PBGA	Function	PBGA	Function	PBGA	Function
A2	I/O<F>	C5	I/O<F>	E7	I/O<F>	G9	V <sub>CCIO&lt;F&gt;</sub>	J11	I/O<F>	L13	V <sub>CC</sub>
A3	I/O<F>	C6	I/O<F>	E8	I/O<F>	G10	I/O<F>	J12	I/O<F>	L14	GND
A4	NC	C7	I/O<F>	E9	IOCTRL<F>	G11	V <sub>CCIO&lt;F&gt;</sub>	J13	I/O<F>	L15	V <sub>CC</sub>
A5	I/O<F>	C8	I/O<F>	E10	I/O<F>	G12	NC	J14	GND	L16	GND
A6	I/O<F>	C9	INREF<F>	E11	I/O<F>	G13	V <sub>CCIO&lt;F&gt;</sub>	J15	I/O<E>	L17	V <sub>CC</sub>
A7	I/O<F>	C10	I/O<F>	E12	I/O<F>	G14	V <sub>CCIO&lt;E&gt;</sub>	J16	I/O<E>	L18	I/O<D>
A8	I/O<F>	C11	I/O<F>	E13	I/O<F>	G15	NC	J17	NC	L19	I/O<D>
A9	NC	C12	I/O<F>	E14	I/O<E>	G16	V <sub>CCIO&lt;E&gt;</sub>	J18	GND	L20	V <sub>CCIO&lt;D&gt;</sub>
A10	I/O<F>	C13	I/O<F>	E15	I/O<E>	G17	I/O<E>	J19	I/O<E>	L21	I/O<D>
A11	I/O<F>	C14	I/O<E>	E16	I/O<E>	G18	V <sub>CCIO&lt;E&gt;</sub>	J20	V <sub>CCIO&lt;D&gt;</sub>	L22	I/O<D>
A12	I/O<F>	C15	I/O<E>	E17	I/O<E>	G19	V <sub>CCIO&lt;E&gt;</sub>	J21	NC	L23	NC
A13	CLK<7>	C16	I/O<E>	E18	I/O<E>	G20	V <sub>CCPLL&lt;1&gt;</sub>	J22	INREF<D>	L24	I/O<D>
A14	CLK<5> /PLLIN<3>	C17	IOCTRL<E>	E19	I/O<E>	G21	I/O<E>	J23	IOCTRL<D>	L25	I/O<D>
A15	I/O<E>	C18	I/O<E>	E20	I/O<E>	G22	I/O<E>	J24	IOCTRL<D>	L26	I/O<D>
A16	I/O<E>	C19	I/O<E>	E21	PLL <sub>RST</sub> <1>	G23	I/O<D>	J25	I/O<D>	M1	I/O<G>
A17	NC	C20	I/O<E>	E22	GND	G24	I/O<D>	J26	I/O<D>	M2	NC
A18	I/O<E>	C21	I/O<E>	E23	I/O<E>	G25	I/O<D>	K1	I/O<G>	M3	I/O<G>
A19	I/O<E>	C22	I/O<E>	E24	I/O<E>	G26	I/O<D>	K2	I/O<G>	M4	I/O<G>
A20	I/O<E>	C23	I/O<E>	E25	I/O<D>	H1	I/O<G>	K3	I/O<G>	M5	I/O<G>
A21	I/O<E>	C24	NC	E26	I/O<D>	H2	I/O<G>	K4	I/O<G>	M6	I/O<G>
A22	I/O<E>	C25	NC	F1	I/O<G>	H3	NC	K5	I/O<G>	M7	I/O<G>
A23	IOCTRL<E>	C26	I/O<D>	F2	I/O<G>	H4	I/O<G>	K6	I/O<G>	M8	I/O<G>
A24	I/O<E>	D1	IOCTRL<G>	F3	I/O<G>	H5	NC	K7	I/O<G>	M9	I/O<G>
A25	I/O<E>	D2	I/O<G>	F4	I/O<F>	H6	I/O<G>	K8	NC	M10	V <sub>CC</sub>
B1	I/O<G>	D3	I/O<F>	F5	GND	H7	V <sub>CCIO&lt;G&gt;</sub>	K9	I/O<G>	M11	V <sub>CC</sub>
B2	V <sub>CCPLL&lt;0&gt;</sub>	D4	I/O<F>	F6	I/O<F>	H8	I/O<F>	K10	GND	M12	GND
B3	I/O<F>	D5	NC	F7	I/O<F>	H9	I/O<F>	K11	V <sub>CC</sub>	M13	GND
B4	I/O<F>	D6	I/O<F>	F8	I/O<F>	H10	I/O<F>	K12	V <sub>CC</sub>	M14	GND
B5	I/O<F>	D7	NC	F9	I/O<F>	H11	I/O<F>	K13	V <sub>CC</sub>	M15	GND
B6	I/O<F>	D8	I/O<F>	F10	I/O<F>	H12	I/O<F>	K14	GND	M16	V <sub>CC</sub>
B7	IOCTRL<F>	D9	I/O<F>	F11	I/O<F>	H13	CLK<8>	K15	V <sub>CC</sub>	M17	V <sub>CC</sub>
B8	I/O<F>	D10	I/O<F>	F12	I/O<F>	H14	CLK<6>	K16	V <sub>CC</sub>	M18	NC
B9	I/O<F>	D11	I/O<F>	F13	I/O<F>	H15	I/O<E>	K17	GND	M19	I/O<D>
B10	I/O<F>	D12	I/O<F>	F14	NC	H16	I/O<E>	K18	I/O<D>	M20	I/O<D>
B11	I/O<F>	D13	NC	F15	I/O<E>	H17	I/O<E>	K19	I/O<D>	M21	I/O<D>
B12	I/O<F>	D14	I/O<E>	F16	I/O<E>	H18	I/O<E>	K20	I/O<D>	M22	I/O<D>
B13	TMS	D15	I/O<E>	F17	I/O<E>	H19	I/O<E>	K21	I/O<D>	M23	I/O<D>
B14	I/O<E>	D16	I/O<E>	F18	I/O<E>	H20	V <sub>CCIO&lt;D&gt;</sub>	K22	I/O<D>	M24	I/O<D>
B15	I/O<E>	D17	NC	F19	NC	H21	I/O<D>	K23	I/O<D>	M25	I/O<D>
B16	I/O<E>	D18	I/O<E>	F20	I/O<E>	H22	I/O<D>	K24	I/O<D>	M26	NC
B17	I/O<E>	D19	I/O<E>	F21	GND <sub>PLL&lt;1&gt;</sub>	H23	I/O<D>	K25	I/O<D>	N1	I/O<G>
B18	I/O<E>	D20	I/O<E>	F22	PLL <sub>OUT</sub> <0>	H24	I/O<D>	K26	I/O<D>	N2	I/O<G>
B19	INREF<E>	D21	I/O<E>	F23	I/O<E>	H25	I/O<D>	L1	I/O<G>	N3	I/O<G>
B20	I/O<E>	D22	I/O<E>	F24	I/O<D>	H26	I/O<D>	L2	I/O<G>	N4	I/O<G>
B21	I/O<E>	D23	I/O<E>	F25	I/O<D>	J1	NC	L3	NC	N5	NC
B22	I/O<E>	D24	NC	F26	I/O<D>	J2	I/O<G>	L4	I/O<G>	N6	I/O<H>
B23	I/O<E>	D25	NC	G1	I/O<G>	J3	IOCTRL<G>	L5	I/O<G>	N7	V <sub>CCIO&lt;G&gt;</sub>
B24	I/O<E>	D26	NC	G2	INREF<G>	J4	I/O<G>	L6	I/O<G>	N8	I/O<G>
B25	I/O<E>	E1	NC	G3	I/O<G>	J5	I/O<G>	L7	V <sub>CCIO&lt;G&gt;</sub>	N9	GND
B26	I/O<D>	E2	I/O<G>	G4	I/O<G>	J6	I/O<G>	L8	I/O<G>	N10	GND
C1	I/O<G>	E3	I/O<F>	G5	PLL <sub>RST</sub> <0>	J7	V <sub>CCIO&lt;G&gt;</sub>	L9	I/O<G>	N11	GND
C2	I/O<F>	E4	I/O<F>	G6	I/O<G>	J8	GND <sub>PLL&lt;0&gt;</sub>	L10	V <sub>CC</sub>	N12	GND
C3	PLL <sub>OUT</sub> <3>	E5	I/O<F>	G7	NC	J9	GND	L11	GND	N13	GND
C4	I/O<F>	E6	I/O<F>	G8	V <sub>CCIO&lt;F&gt;</sub>	J10	NC	L12	V <sub>CC</sub>	N14	GND

(Sheet 1 of 3)

Table 25: 672 PBGA Pinout Table (Continued)

PBGA	Function	PBGA	Function	PBGA	Function	PBGA	Function	PBGA	Function	PBGA	Function
N15	GND	R15	GND	U15	V <sub>CC</sub>	W16	I/O<B>	AA17	I/O<B>	AC18	I/O<B>
N16	V <sub>CC</sub>	R16	V <sub>CC</sub>	U16	V <sub>CC</sub>	W17	NC	AA18	I/O<B>	AC19	NC
N17	V <sub>CC</sub>	R17	V <sub>CC</sub>	U17	GND	W18	I/O<B>	AA19	I/O<B>	AC20	I/O<B>
N18	I/O<D>	R18	I/O<C>	U18	I/O<C>	W19	GNDPLL<2>	AA20	I/O<B>	AC21	I/O<B>
N19	NC	R19	I/O<C>	U19	I/O<C>	W20	V <sub>CCIO</sub> <C>	AA21	I/O<B>	AC22	TDO
N20	V <sub>CCIO</sub> <D>	R20	I/O<C>	U20	I/O<C>	W21	I/O<B>	AA22	PLLRST<2>	AC23	I/O<B>
N21	V <sub>CC</sub>	R21	NC	U21	I/O<C>	W22	NC	AA23	I/O<B>	AC24	I/O<B>
N22	NC	R22	I/O<C>	U22	I/O<C>	W23	I/O<C>	AA24	I/O<C>	AC25	I/O<C>
N23	I/O<D>	R23	I/O<C>	U23	IOCTRL<C>	W24	NC	AA25	I/O<C>	AC26	I/O<C>
N24	I/O<D>	R24	I/O<C>	U24	INREF<C>	W25	IOCTRL<C>	AA26	I/O<C>	AD1	I/O<H>
N25	I/O<D>	R25	NC	U25	I/O<C>	W26	I/O<C>	AB1	I/O<H>	AD2	I/O<H>
N26	I/O<C>	R26	I/O<C>	U26	I/O<C>	Y1	NC	AB2	I/O<H>	AD3	NC
P1	I/O<H>	T1	I/O<H>	V1	I/O<H>	Y2	NC	AB3	I/O<A>	AD4	I/O<A>
P2	TCK	T2	I/O<H>	V2	I/O<H>	Y4	I/O<H>	AB4	I/O<A>	AD5	I/O<A>
P3	I/O<H>	T3	I/O<H>	V3	I/O<H>	Y5	I/O<H>	AB5	I/O<A>	AD6	I/O<A>
P4	NC	T4	I/O<H>	V4	I/O<H>	Y6	I/O<A>	AB6	PLLRST<3>	AD7	I/O<A>
P5	V <sub>CC</sub>	T5	I/O<H>	V5	I/O<H>	Y7	NC	AB7	I/O<A>	AD8	I/O<A>
P6	I/O<H>	T6	I/O<H>	V6	I/O<H>	Y8	I/O<A>	AB8	NC	AD9	IOCTRL<A>
P7	V <sub>CCIO</sub> <H>	T7	V <sub>CCIO</sub> <H>	V7	V <sub>CCIO</sub> <H>	Y9	V <sub>CCIO</sub> <A>	AB9	I/O<A>	AD10	I/O<A>
P8	I/O<H>	T8	I/O<H>	V8	GNDPLL<3>	Y10	V <sub>CCIO</sub> <A>	AB10	I/O<A>	AD11	I/O<A>
P9	I/O<H>	T9	I/O<A>	V9	GND	Y11	NC	AB11	I/O<A>	AD12	I/O<A>
P10	V <sub>CC</sub>	T10	V <sub>CC</sub>	V10	I/O<A>	Y12	V <sub>CCIO</sub> <A>	AB12	I/O<A>	AD14	I/O<A>
P11	V <sub>CC</sub>	T11	GND	V11	I/O<A>	Y13	I/O<A>	AB13	I/O<A>	AD13	I/O<B>
P12	GND	T12	V <sub>CC</sub>	V12	I/O<A>	Y14	V <sub>CCIO</sub> <A>	AB14	CLK<3>/PLLI N<1>	AD15	I/O<B>
P13	GND	T13	GND	V13	GND	Y15	V <sub>CCIO</sub> <B>	AB15	I/O<B>	AD16	I/O<B>
P14	GND	T14	V <sub>CC</sub>	V14	I/O<B>	Y16	V <sub>CC</sub>	AB16	I/O<B>	AD17	I/O<B>
P15	GND	T15	GND	V15	NC	Y17	V <sub>CCIO</sub> <B>	AB17	I/O<B>	AD18	I/O<B>
P16	GND	T16	I/O<B>	V16	I/O<B>	Y18	I/O<B>	AB18	I/O<B>	AD19	I/O<B>
P17	GND	T17	V <sub>CC</sub>	V18	I/O<B>	Y19	V <sub>CCIO</sub> <B>	AB19	I/O<B>	AD20	I/O<B>
P18	GND	T18	I/O<C>	V19	GND	Y20	V <sub>CCIO</sub> <B>	AB20	I/O<B>	AD21	I/O<B>
P19	I/O<D>	T19	I/O<C>	V20	I/O<C>	Y21	I/O<B>	AB21	PLLOUT<1>	AD22	I/O<B>
P20	V <sub>CCIO</sub> <C>	T20	V <sub>CCIO</sub> <C>	V21	V <sub>CCIO</sub> <C>	Y22	I/O<B>	AB22	GND	AD23	I/O<B>
P21	I/O<C>	T21	I/O<C>	V22	I/O<C>	Y23	V <sub>CCPLL</sub> <2>	AB23	I/O<B>	AD24	NC
P22	I/O<C>	T22	I/O<C>	V23	NC	Y24	I/O<C>	AB24	NC	AD25	I/O<B>
P23	I/O<C>	T23	I/O<C>	V24	I/O<C>	Y25	I/O<C>	AB25	I/O<C>	AD26	I/O<C>
P24	I/O<C>	T24	I/O<C>	V25	I/O<C>	Y26	I/O<C>	AB26	NC	AE1	I/O<H>
P25	I/O<C>	T25	I/O<C>	V26	NC	AA1	I/O<H>	AC2	IOCTRL<H>	AE2	I/O<A>
P26	TRSTB	T26	I/O<C>	W1	I/O<H>	AA2	NC	AC3	I/O<H>	AE3	I/O<A>
R1	I/O<H>	U1	I/O<H>	W2	INREF<H>	AA3	I/O<H>	AC4	NC	AE4	I/O<A>
R2	I/O<H>	U2	I/O<H>	W3	I/O<H>	AA4	I/O<A>	AC5	GND	AE5	I/O<A>
R3	NC	U3	IOCTRL<H>	W4	I/O<H>	AA5	PLLOUT<2>	AC6	I/O<A>	AE6	I/O<A>
R4	I/O<H>	U4	I/O<H>	W5	I/O<H>	AA6	GND	AC7	I/O<A>	AE7	INREF<A>
R5	I/O<H>	U5	I/O<H>	W6	NC	AA7	V <sub>CCPLL</sub> <3>	AC8	I/O<A>	AE8	I/O<A>
R6	I/O<H>	U6	I/O<H>	W7	V <sub>CCIO</sub> <H>	AA8	I/O<A>	AC9	I/O<A>	AE9	I/O<A>
R7	I/O<H>	U7	I/O<H>	W8	I/O<A>	AA9	I/O<A>	AC10	I/O<A>	AE10	I/O<A>
R8	I/O<H>	U8	I/O<A>	W9	I/O<A>	AA10	I/O<A>	AC11	I/O<A>	AE11	I/O<A>
R9	I/O<H>	U9	I/O<A>	W10	I/O<A>	AA11	NC	AC12	NC	AE12	I/O<A>
R10	V <sub>CC</sub>	U10	GND	W11	I/O<A>	AA12	I/O<A>	AC13	I/O<A>	AE13	TDI
R11	V <sub>CC</sub>	U11	V <sub>CC</sub>	W12	I/O<A>	AA13	I/O<A>	AC14	NC	AE14	CLK<4> DEDCLK/PLLI N<0>
R12	GND	U12	V <sub>CC</sub>	W13	CLK<1>	AA14	I/O<B>	AC15	I/O<B>	AE15	I/O<B>
R13	GND	U13	GND	W14	NC	AA15	I/O<B>	AC16	I/O<B>	AE16	I/O<B>
R14	GND	U14	V <sub>CC</sub>	W15	I/O<B>	AA16	I/O<B>	AC17	I/O<B>	AE17	I/O<B>

(Sheet 2 of 3)

Table 25: 672 PBGA Pinout Table (Continued)

PBGA	Function	PBGA	Function	PBGA	Function	PBGA	Function	PBGA	Function	PBGA	Function
AE18	I/O<B>	AE24	I/O<B>	AF5	I/O<A>	AF11	I/O<A>	AF17	I/O<B>	AF23	INREF<B>
AE19	IOCTRL<B>	AE25	I/O<B>	AF6	I/O<A>	AF12	I/O<A>	AF18	NC	AF24	I/O<B>
AE20	IOCTRL<B>	AE26	I/O<C>	AF7	I/O<A>	AF13	CLK<0>	AF19	I/O<B>	AF25	I/O<B>
AE21	I/O<B>	AF2	I/O<A>	AF8	I/O<A>	AF14	CLK<2> /PLLIN<2>	AF20	I/O<B>		
AE22	I/O<B>	AF3	I/O<A>	AF9	I/O<A>	AF15	I/O<B>	AF21	NC		
AE23	I/O<B>	AF4	IOCTRL<A>	AF10	NC	AF16	I/O<B>	AF22	I/O<B>		

(Sheet 3 of 3)

## 672 PBGA Packaging Drawing

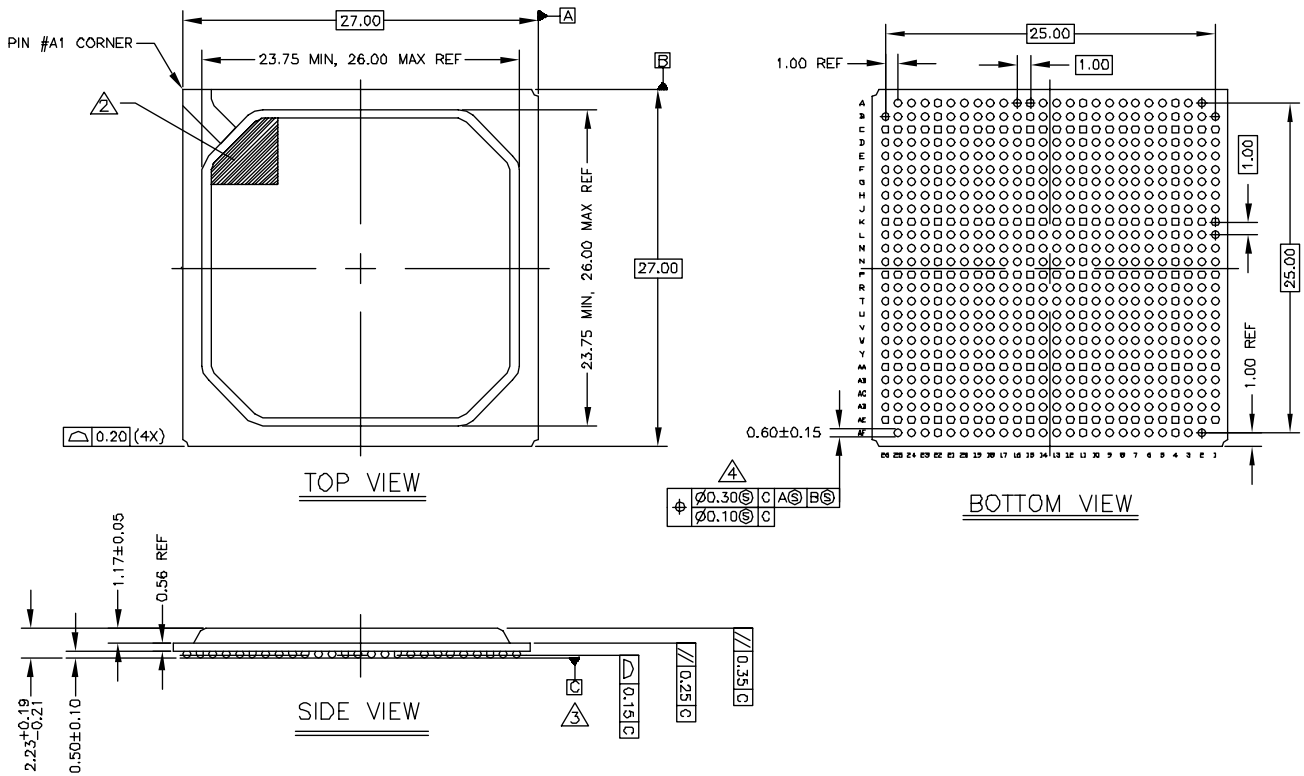

Figure 31: 672 PBGA Packaging Drawing

## Ordering Information

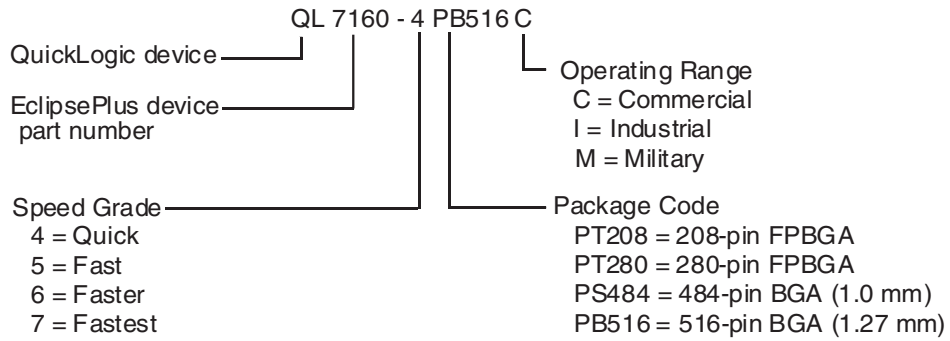

Figure 32: Ordering Information

## Contact Information

Telephone: 408 990 4000 (US)  
416 497 8884 (Canada)  
44 1932 57 9011 (Europe)  
49 89 930 86 170 (Germany)  
852 8106 9091 (Asia)  
81 45 470 5525 (Japan)

E-mail: [info@quicklogic.com](mailto:info@quicklogic.com)  
Support: [support@quicklogic.com](mailto:support@quicklogic.com)  
Web site: <http://www.quicklogic.com/>

## Revision History

Table 26: Revision History

Revision	Date	Comments
A	August 2002	Brian Faith, Judd Heape, Andreea Rotaru, Paul Micallef

## Copyright Information

Copyright © 2002 QuickLogic Corporation.

All Rights Reserved.

The information contained in this product brief, and the accompanying software programs are protected by copyright. All rights are reserved by QuickLogic Corporation. QuickLogic Corporation reserves the right to make periodic modifications of this product without obligation to notify any person or entity of such revision. Copying, duplicating, selling, or otherwise distributing any part of this product without the prior written consent of an authorized representative of QuickLogic is prohibited.

QuickLogic, QuickWorks, pASIC, and ViaLink are registered trademarks of QuickLogic Corporation.

All trademarks and registered trademarks are the property of their respective owners.