

# RMBA09500-58

## Cellular 2 Watt Linear GaAs MMIC Power Amplifier

ADVANCED INFORMATION

**Description**

The RMBA09500 is a high power, highly linear Power Amplifier. The two stage circuit uses Raytheon's pHEMT process. It is designed for use as a driver stage for Cellular base stations, or as the output stage for Micro- and Pico-Cell base stations. The amplifier has been optimized for high linearity requirements for CDMA operation. The device is matched for 50 ohms input impedance.

**Features**

- ◆ 2 Watt Linear output power at 37 dBc ACPR1 for CDMA operation
- ◆ Small Signal Gain of > 30 dB
- ◆ Small outline SMD package

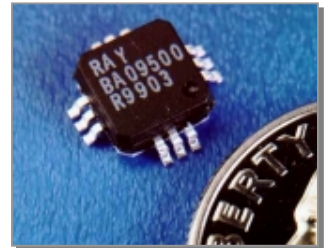

**Absolute Maximum Ratings<sup>1</sup>**

Parameter	Symbol	Min	Typical	Max	Units
Drain Supply Voltage	$V_{DD}$			+10	V
Gate Supply Voltage	$V_{GS}$			-5	V
RF Input Power (50 ohm Source)	$P_{RF}$			+5	dBm
Case Operating Temperature	$T_C$	-30		+85	°C
Storage Temperature	$T_S$	-40		+100	°C

**Electrical Characteristics<sup>2</sup>**

Parameter	Min	Typ	Max	Unit
Frequency Range	869		894	MHz
Gain (small signal)		32		dB
Gain variation:				
Over frequency range		+/-1.5		dB
Over temperature range		+/-2.5		dB
Noise Figure		6		dB
Linear output power:				
for CDMA <sup>3</sup>	33			dBm
Saturated output power		38		dBm

Parameter	Min	Typ	Max	Unit
PAE		20		%
Input VSWR (50Ω)		2:1		
RF Input Power		+1		dBm
Drain Voltage ( $V_{DD}$ )		7.0		Volts
Gate Voltage ( $V_{GS}$ ) <sup>4</sup>		-3		Volts
Quiescent current (IDQ1, IDQ2)		150, 400		mA
Thermal Resistance (Channel to Case) $R_{jc}$		11		°C/W

**Notes:**

1. Not with RF power simultaneously applied.
2. 50 ohm system,  $V_{DD} = 7.0V$ ,  $T = 25°C$
3. 9 Channel Forward Link QPSK Source; 1.23 Mbps modulation rate. ACPR1 measured at 885 KHz offset at a value  $\geq 37$  dBc. CDMA Waveform measured using the ratio of the average power within the 1.23 MHz channel and within a 30 kHz bandwidth at an 885 MHz offset.
4. Gate Voltage can be adjusted to optimize the linearity of the amplifier for differing modulation systems. Default biasing is optimized for CDMA (Ref. Note 2).

Characteristic performance data and specifications are subject to change without notice.

# RMBA09500-58

## Cellular 2 Watt Linear GaAs MMIC Power Amplifier

**Application Information**

**CAUTION: THIS IS AN ESD SENSITIVE DEVICE.**

The following describes a procedure for evaluating the RMBA09500-58, a monolithic high efficiency power amplifier, in a surface mount package, designed for use as a driver stage for Cellular base stations, or as the final output stage for Micro- and Pico-Cell base stations. Figure 1 shows the package outline and the pin designations. Figure 2 shows the functional block diagram of the packaged product. It should be noted that RMBA09500-58 requires external passive components for DC bias and RF output matching circuits. A recommended schematic circuit is shown in Figure 3. The gate biases for the two stages of the amplifier may be be set by simple resistive voltage dividers. Figure 4 shows a typical layout of an evaluation board, corresponding to the schematic circuits of figure 3. The following designations should be noted:

- (1) Pin designations are as shown in figure 2.
  - (2) Vg1 and Vg2 are the Gate Voltages (negative) applied at the pins of the package
  - (3) Vgg1 and Vgg2 are the negative supply voltages at the evaluation board terminals
  - (4) Vd1 and Vd2 are the Drain Voltages (positive) applied at the pins of the package
  - (5) Vdd1 and Vdd2 are the positive supply voltages at the evaluation board terminals
- Note: The 2 terminals of Vdd1 and Vdd2 may be tied together.
- The base of the package must be soldered on to a heat sink for proper operation.

**Figure 1**  
Package Outline and Pin Designations

Dimensions in inches

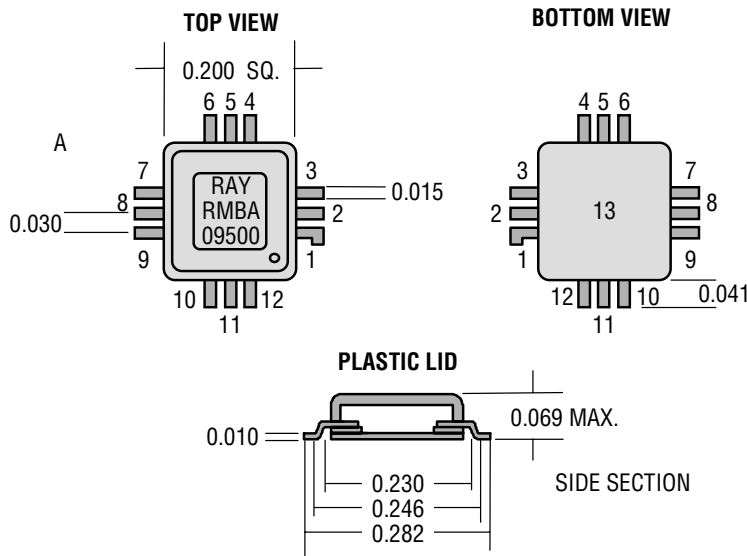

Pin #	Description
1	RF Out & Vd2
2	RF Out & Vd2
3	RF Out & Vd2
4	AC Ground (g2)
5	GND
6	AC Ground (g1)
7	GND
8	RF Input
9	GND
10	Vd1
11	Vg2
12	Vg1
13	GND (METAL BASE)

**Figure 2**  
Functional Block Diagram of Packaged Product

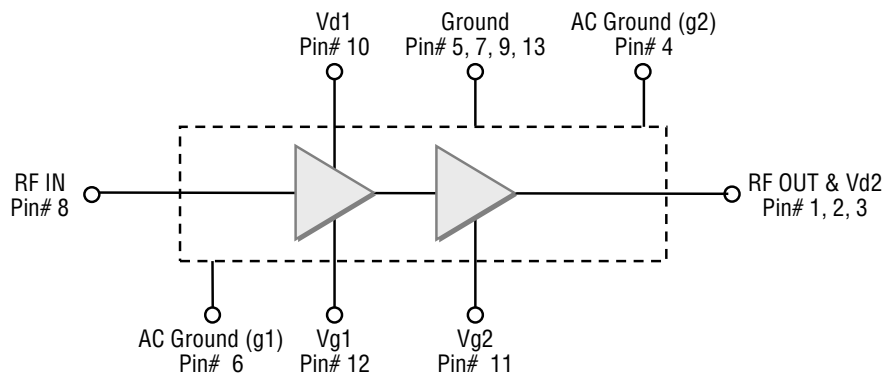

Characteristic performance data and specifications are subject to change without notice.

# RMBA09500-58

## Cellular 2 Watt Linear GaAs MMIC Power Amplifier

ADVANCED INFORMATION

**Figure 3**  
Schematic of Application Circuit showing external components

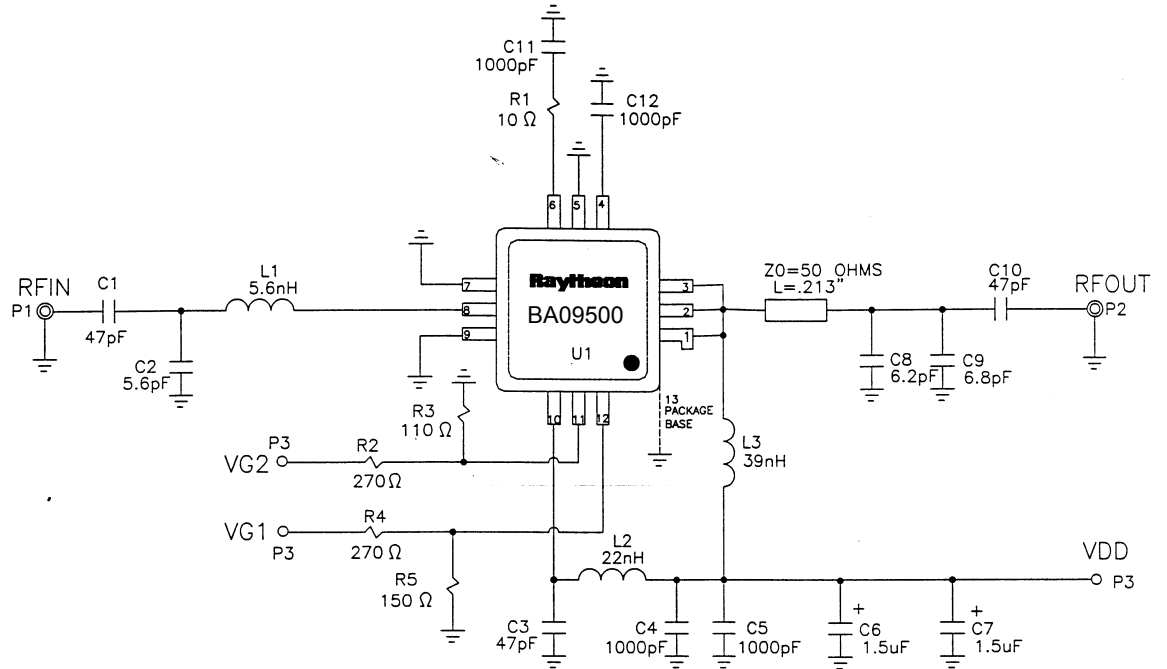

**Figure 4**  
Layout of Test Evaluation Board (RMBA09500-58-TB)

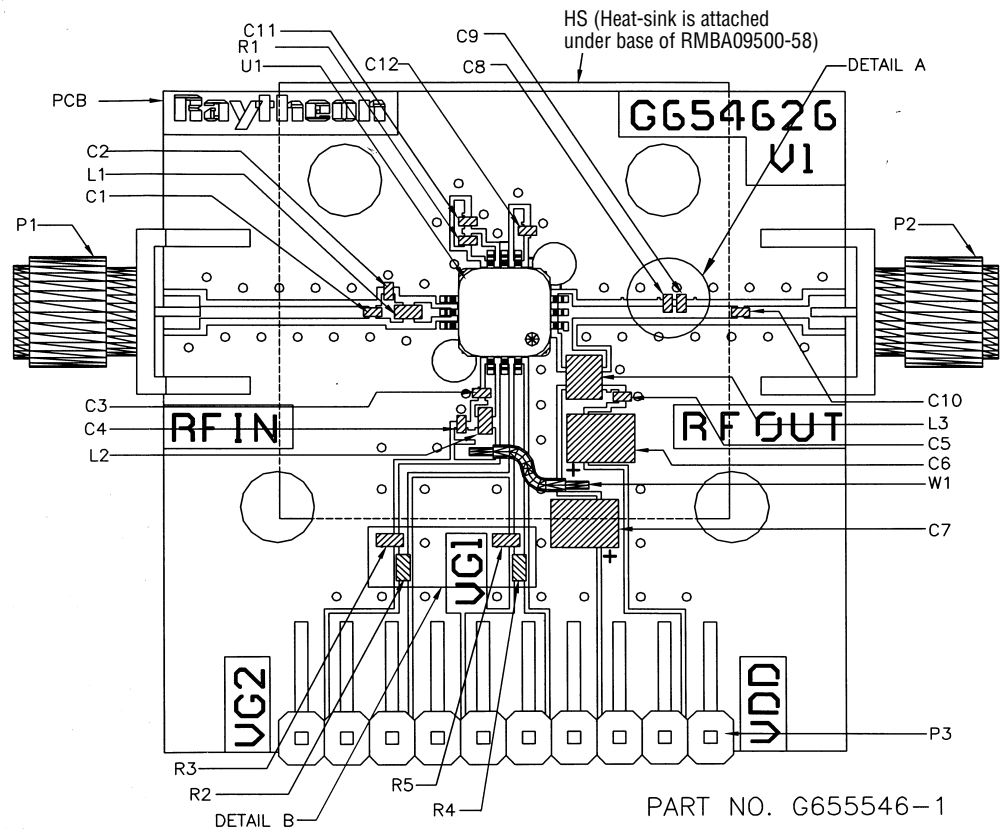

Characteristic performance data and specifications are subject to change without notice.

# RMBA09500-58

## Cellular 2 Watt Linear GaAs MMIC Power Amplifier

ADVANCED INFORMATION

### Test Procedure

for the evaluation board  
(RMBA09500-58-TB)

**CAUTION: LOSS OF GATE VOLTAGES (VG1, VG2) WHILE CORRESPONDING DRAIN VOLTAGES (Vdd) ARE PRESENT CAN DAMAGE THE AMPLIFIER.**

The following sequence must be followed to properly test the amplifier. (It is necessary to add a fan to provide air cooling across the heat sink of RMBA09500.) Note: Vdd1, 2 are tied together.

**Step 1:** Turn off RF input power.

**Step 2:** Use GND terminal of the evaluation board for the ground of the DC supplies. Slowly apply gate supply voltages as specified on results sheet supplied with test board to the board terminals Vgg1 and Vgg2.

**Step 3:** Slowly apply drain supply voltages of +7.0 V to the board terminals Vdd1, 2. Adjust Vgg to set the total quiescent current Idq1 and Idq2 (with no RF applied) Idq as per supplied result sheet. Gate supply voltages (Vgg i.e., Vgg1, Vgg2) may be adjusted, only if quiescent current (Idq1 and Idq2) values desired are different from those noted on the data summary supplied with product samples.

**Step 4:** After the bias condition is established, RF input signal may now be applied at the appropriate frequency band and appropriate power level.

**Step 5:** Follow turn-off sequence of:

- (i) Turn off RF Input Power
- (ii) Turn down and off drain voltages Vdd1, 2.
- (iii) Turn down and off gate voltages Vgg1 and Vgg2.

### Parts List

for Test Evaluation Board  
(RMBA09500-58-TB,  
G654188/G654942)

Part	Value	EIA Size	Vendor(s)
C1,C3,C10	47 pF	0402	Murata, GRM36COG470J050
C2	5.6 pF	0402	Murata, GRM36COG5R6B050
C8	6.2 pF	0402	Murata, GRM36COG6R2B050
C9	6.8 pF	0402	Murata, GRM36COG6R8B050
C4,C5,C11,C12	1000 pF	0402	Murata, GRM36X7R102K050
C6,C7	1.5 uF	3528	Kemet (T494B155K020AS)
L1	5.6 nH	0603	Toko, LL1608-FH5N6S
L2	22 nH	0603	Toko, LL608-FH22NK
L3	39 nH	1008	Coilcraft, 1008HS-390TKBC
R1	10 Ohm	0402	IMS, RCI-0402-10R0J
W1	26AWG (0.015" dia) Wire		Alpha, 2853/1
U1	RMBA09500-58, 3.5V PA		Raytheon, G654257
P3	Right angle Pin Header		3M (2340-5211TN)
P1,P2	SMA Connectors		Johnson Components (142-0701-841)
Board	FR4		Raytheon Dwg# G654626, V1
R2, R4	270 ohm	0402	IMS RCI 0402 2700J
R3	110 ohm	0402	IMS RCI 0402 1100J
R5	150 ohm	0402	IMS RCI 0402 1500J

### Recommendations

for Heat-Sinking the  
RMBA09500-58

Use SN92 solder to attach the device to a small copper pedestal at 185°C for 10 seconds. The copper pedestal should be flush with the top surface of the PWB and be soldered to the rear side of the PWB again using SN92 at 185°C with a sufficient flange to allow attachment of the pedestal, PWB and MMIC to a suitable heat-sink. This operation will assure that the total thermal resistance of the MMIC to the heat-sink is 13°C/watt and the junction temperature is below 150°C at a case temperature of 85°C.

Characteristic performance data and specifications are subject to change without notice.

# RMBA09500-58

## Cellular 2 Watt Linear GaAs MMIC Power Amplifier

ADVANCED INFORMATION

Performance Data

CDMA: 9 Channel Forward Link

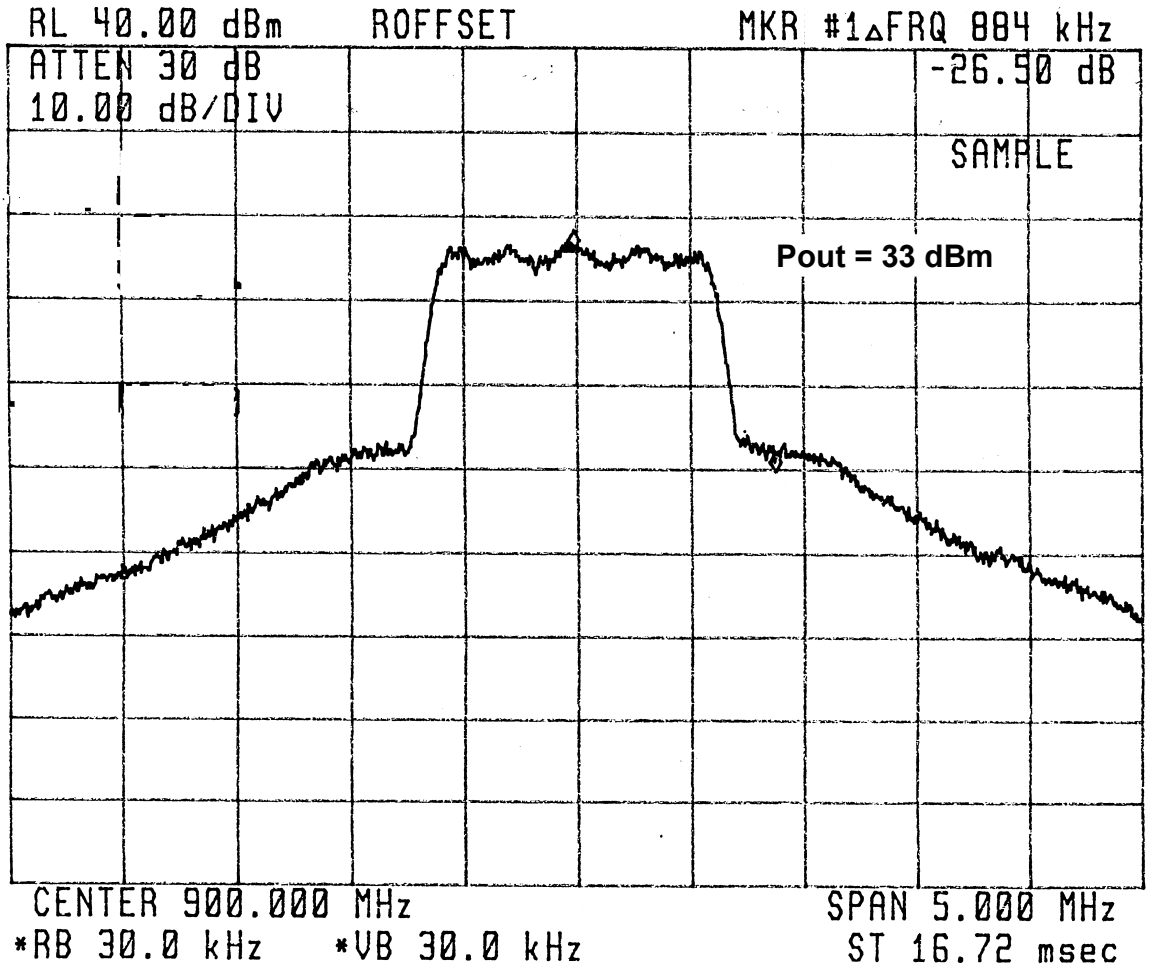

Characteristic performance data and specifications are subject to change without notice.

# Worldwide Sales Representatives

## North America

**D&L Technical Sales**  
6139 S. Rural Road, #102  
Tempe, AZ 85283  
480-730-9553  
fax: 480-730-9647  
Nicholas Delvecchio, Jr.  
dlarizona@aol.com

**Hi-Peak Technical Sales**  
P.O. Box 6067  
Amherst, NH 03031  
866-230-5453  
fax: 603-672-9228  
sales@hi-peak.com

**Spartech South**  
2115 Palm Bay Road, NE,  
Suite 4  
Palm Bay, FL 32904  
321-727-8045  
fax: 321-727-8086  
Jim Morris  
jim@spartech-south.com

**TEQ Sales, Inc.**  
920 Davis Road, Suite 304  
Elgin, IL 60123  
847-742-3767  
fax: 847-742-3947  
Dennis Culpepper  
dculpepper@teqsales.com

**Cantec Representatives**  
8 Strathearn Ave, No. 18  
Brampton, Ontario  
Canada L6T 4L9  
905-791-5922  
fax: 905-791-7940  
Dave Batten  
cantec-ott@cantec-o.net

**Steward Technology**  
6990 Village Pkwy #206  
Dublin, CA 94568  
925-833-7978  
fax: 925-560-6522  
John Steward  
johnsteward1@msn.com

## Europe

**Sangus OY**  
Lunkintie 21,  
90460 Oulunsalo  
Finland  
358-8-8251-100  
fax: 358-8-8251-110  
Juha Virtala  
juha.virtala@sangus.fi

**Sangus AB**  
Berghamnvgagen 68  
Box 5004  
S-165 10 Hasselby  
Sweden  
Ronny Gustafson  
468-0-380210  
fax: 468-0-3720954

**Globes Elektronik & Co.**  
Klarastrabe 12  
74072 Heilbronn  
Germany  
49-7131-7810-0  
fax: 49-7131-7810-20  
Ulrich Blievernicht  
hfwelt@globes.de

**MTI Engineering Ltd.**  
Afek Industrial Park  
Hamelacha 11  
New Industrial Area  
Rosh Hayin 48091  
Israel  
972-3-902-5555  
fax: 972-3-902-5556  
Adi Peleg  
adi\_p@mti-group.co.il

**Sirces srl**  
Via C. Boncompagni, 3B  
20139 Milano  
Italy  
3902-57404785  
fax: 3902-57409243  
Nicola Iacovino  
nicola.iacovino@sirces.it

## Asia

**ITX Corporation**  
2-5, Kasumigaseki  
3-Chome  
Chiyoda-Ku  
Tokyo 100-6014 Japan  
81-3-4288-7073  
fax: 81-3-4288-7243  
Maekawa Ryosuke  
maekawa.ryosuke@  
itx-corp.co.jp

**Sea Union**  
9F-1, Building A, No 19-3  
San-Chung Road  
Nankang Software Park  
Taiwan, ROC  
Taipei 115  
02-2655-3989  
fax: 02-2655-3918  
Murphy Su  
murphy@seaunionweb.com.tw

## Worldwide Distribution

**Headquarters**  
Avnet-MCS  
6321 San Ignacio Drive  
San Jose, CA 95119  
408-360-4073  
fax: 408-281-8802  
Art Herbig  
art.herbig@avnet.com

**Belgium and Luxembourg**  
BFI Optilas  
Cipalstraat  
2440 GEEL  
Belgium  
32 14 570670  
fax: 32 14 570679  
sales.be@bfiptilas.avnet.com

**United Kingdom**  
BFI Optilas  
Burnt Ash Road  
Aylesford, Kent  
England  
ME207XB  
44 1622882467  
fax: 44 1622882469  
rfsales.uk@  
bfiptilas.avnet.com

**France**  
BFI Optilas  
4 Allee du Cantal  
Evrly, Cedex  
France  
33 16079 5900  
fax: 33 16079 8903  
sales.fr@  
bfiptilas.avnet.com

**Holland**  
BFI Optilas  
Chr. Huygensweg 17  
2400 AJ ALPHEN AAN DEN  
RIJN  
The Netherlands  
31 172 446060  
fax: 33 172 443414  
sales.nl@  
bfiptilas.avnet.com

**Spain**  
BFI Optilas  
C/Isobel Colbrand, 6 - 4a  
28050 Madrid  
Spain  
34 913588611  
fax: 34 913589271  
sales.es@  
bfiptilas.avnet.com

## Sales Office Headquarters

**United States (East Coast)**  
Raytheon  
362 Lowell Street  
Andover, MA 01810  
978-684-8628  
fax: 978-684-8646  
Walter Shelmet  
wshelmet@  
rrfc.raytheon.com

**United States (West Coast)**  
Raytheon  
362 Lowell Street  
Andover, MA 01810  
978-684-8919  
fax: 978-684-8646  
Rob Sinclair  
robert\_w\_sinclair@  
rrfc.raytheon.com

**Europe**  
Raytheon  
AM Teckenberg 53  
40883 Ratingen  
Germany  
49-2102-706-155  
fax: 49-2102-706-156  
Peter Hales  
peter\_j\_hales@  
raytheon.com

**Asia**  
Raytheon  
Room 601, Gook Je Ctr. Bldg  
191 Hangang Ro 2-GA  
Yongsan-Gu, Seoul,  
Korea 140-702  
82-2-796-5797  
fax: 82-2-796-5790  
T.G. Lee  
tg\_lee@  
rrfc.raytheon.com

## Customer Support

978-684-8900

fax: 978-684-5452

customer\_support@rrfc.raytheon.com