

RMPA39000

37-40 GHz GaAs MMIC Power Amplifier

PRODUCT INFORMATION

Description

The Raytheon RMPA39000 is a high efficiency power amplifier designed for use in point to point radio, point to multi point communications, LMDS and other millimeter-wave applications. The RMPA39000 is a 3-stage GaAs MMIC amplifier chip utilizing Raytheon's advanced 0.15 μ m gate length Power PHEMT process and can be used in conjunction with other driver or power amplifiers to achieve the required total power output.

Features

- ◆ 24 dB small signal gain (typ.)
- ◆ 29 dBm saturated power output (typ.)
- ◆ Circuit contains individual vias
- ◆ Chip size 4.28mm x 2.90 mm

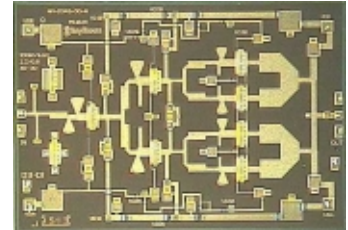

Absolute Maximum Ratings

Parameter	Symbol	Value	Units
Positive DC Voltage (5V Typical)	Vd	+ 6	Volts
Negative DC Voltage	Vg	- 2	Volts
Simultaneous (Vd-Vg)	Vdg	+ 8	Volts
Positive DC Current	Id	1092	mA
RF Input Power (from 50 ohm source)	PIN	+20	dBm
Operating Base plate Temperature	TC	-30 to +85	°C
Storage Temperature Range	TStg	-55 to +125	°C
Thermal Resistance (Channel to Backside)	Rjc	17	°C/W

Electrical Characteristics

50 ohm system,
Vd = +5V,
Quiescent current
(Idq) = 700 mA

Parameter	Min	Typ	Max	Unit
Frequency Range	37		40	GHz
Gate Supply Voltage (Vg) ¹		-0.15		V
Gain Small Signal at Pin=0dBm	20	24		dB
Gain Variation vs Freq		±1		dB
Power Output at 1 dB Compression		28		dBm
Power Output Saturated (Pin = + 13dBm)	27.5	29		dBm
Drain Current at Pin = 0 dBm		700		mA

Parameter	Min	Typ	Max	Unit
Drain Current at P1 dB Compression		730		mA
Drain Current at Psat (Pin= + 13dBm)		750		mA
Power Added Efficiency (PAE) at P1 dB		17		%
Input Return Loss (Pin = -10 dBm)		8		dB
Output Return Loss (Pin = -10 dBm)		7		dB

Note: 1. Typical range of the negative gate voltages is -0.5 to 0.0V to set typical Idq of 700 mA.

Characteristic performance data and specifications are subject to change without notice.

RMPA39000

37-40 GHz GaAs MMIC Power Amplifier

Application Information

CAUTION: THIS IS AN ESD SENSITIVE DEVICE.

Chip carrier material should be selected to have GaAs compatible thermal coefficient of expansion and high thermal conductivity such as copper molybdenum or copper tungsten. The chip carrier should be machined, finished flat, plated with gold over nickel and should be capable of withstanding 325°C for 15 minutes.

Die attachment for power devices should utilize Gold/Tin (80/20) eutectic alloy solder and should avoid hydrogen environment for PHEMT devices. Note that the backside of the chip is gold plated and is used as RF and DC Ground.

These GaAs devices should be handled with care and stored in dry nitrogen environment to prevent contamination of bonding surfaces. These are ESD sensitive devices and should be handled with appropriate precaution including the use of wrist-grounding straps. All die attach and wire/ribbon bond equipment must be well grounded to prevent static discharges through the device.

Recommended wire bonding uses 3 mils wide and 0.5 mil thick gold ribbon with lengths as short as practical allowing for appropriate stress relief. The RF input and output bonds should be typically 0.012" long corresponding to a typical 2 mil gap between the chip and the substrate material.

Figure 1
Functional Block Diagram

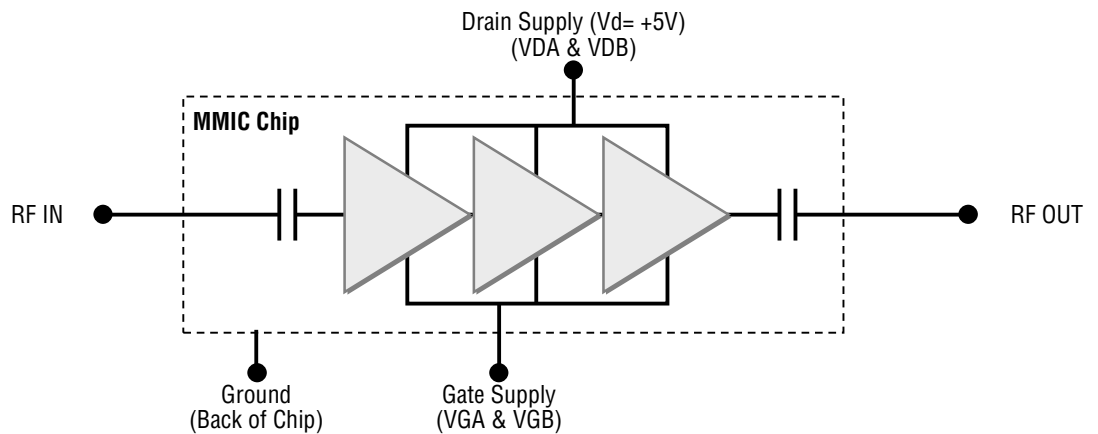
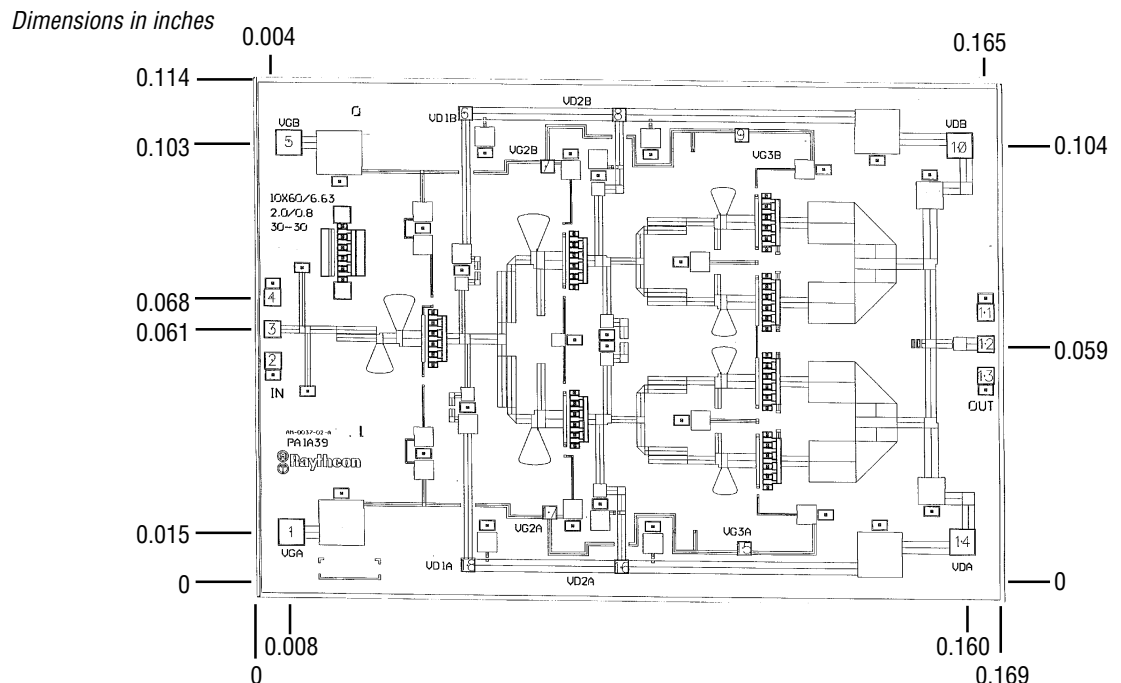

Figure 2
Chip Layout and Bond Pad Locations

(Chip Size = 0.169" x 0.114" x 0.002"
Back of Chip is RF and DC Ground)



Characteristic performance data and specifications are subject to change without notice.

RMPA39000

37-40 GHz GaAs MMIC Power Amplifier

Figure 3
Recommended
Application Schematic
Circuit Diagram

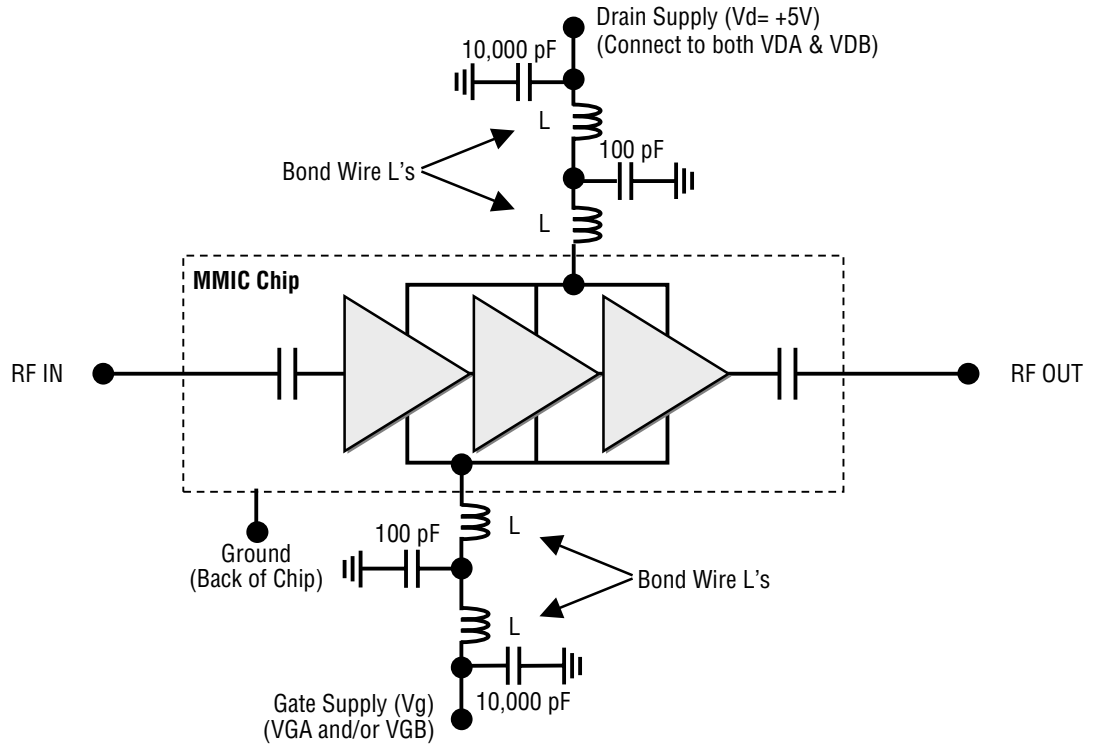
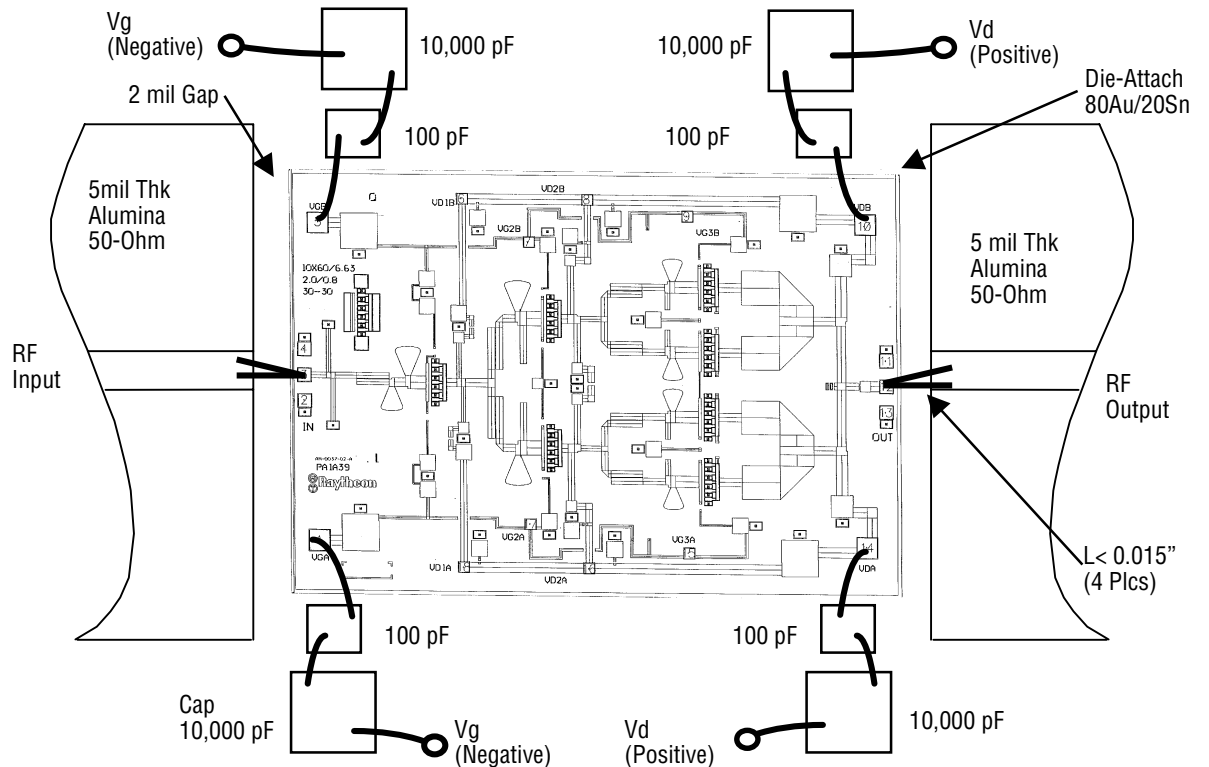

Figure 4
Recommended
Assembly and Bonding
Diagram



Note:
Use 0.003" x 0.0005" Gold Ribbon for bonding. RF input and output bonds should be less than 0.015" long with stress relief.

Characteristic performance data and specifications are subject to change without notice.

RMPA39000

37-40 GHz GaAs MMIC Power Amplifier

PRODUCT INFORMATION

Recommended Procedure

for biasing and operation

CAUTION: LOSS OF GATE VOLTAGE (V_g) WHILE DRAIN VOLTAGE (V_d) IS PRESENT MAY DAMAGE THE AMPLIFIER CHIP.

The following sequence of steps must be followed to properly test the amplifier:

Step 1: Turn off RF input power

Step 2: Connect the DC Supply grounds to the ground of the chip carrier. Slowly apply negative gate bias supply voltage of -1.5 V to V_g

Step 3: Slowly apply positive drain bias supply voltage of +5 V to V_d

Step 4: Adjust gate bias voltage to set the quiescent current of $I_{dq}=700$ mA

Step 5: After the bias condition is established, RF input signal may now be applied at the appropriate frequency band.

Step 6: Follow turn-off sequence of:

- (i) Turn off RF input power
- (ii) Turn down and off drain voltage (V_d)
- (iii) Turn down and off gate bias voltage (V_g)

Performance Data

RMPA39000 Gain Vs. Frequency $V_d=5V$, $I_d=700mA$

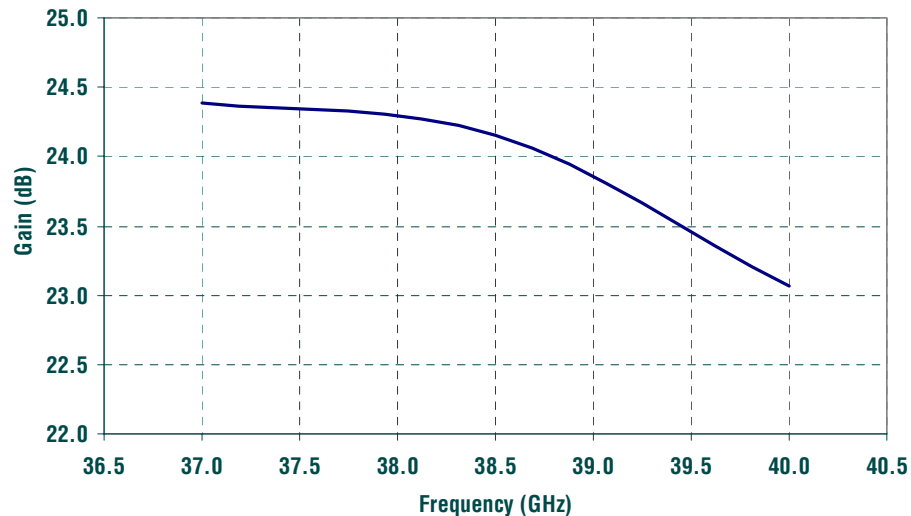

RMPA39000 Saturated Pout Vs. Frequency $V_d=5V$, $I_d=700mA$

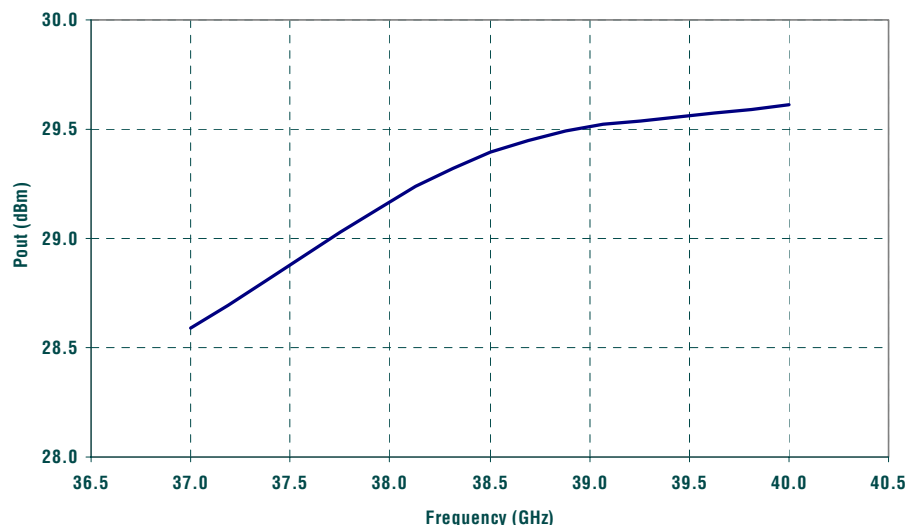

Characteristic performance data and specifications are subject to change without notice.

RMPA39000

37-40 GHz GaAs MMIC Power Amplifier

Performance Data

RMPA39000 S-Parameters Vs. Frequency Vd=5V, Idq=700mA

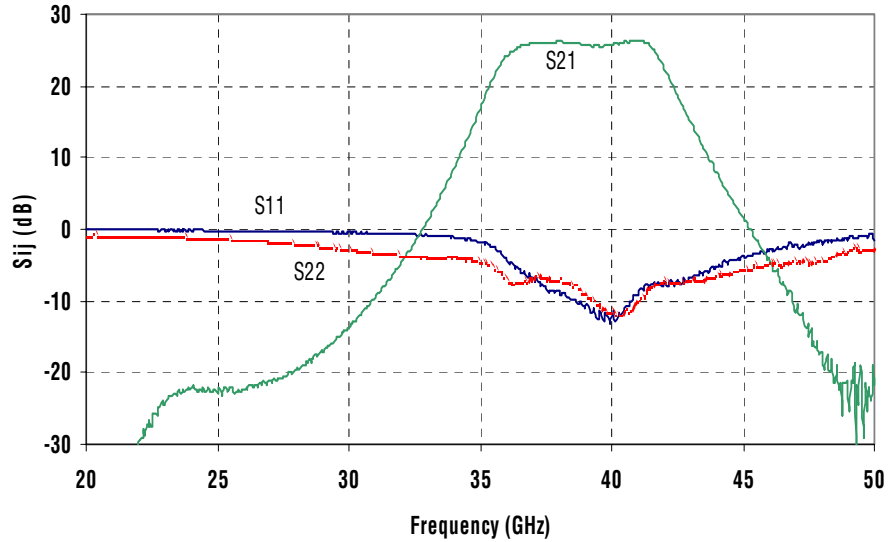

Output Power, Power Added Efficiency, Gain and Compression
Bias Conditions: Vd=5V Iq=700mA F=37 GHz

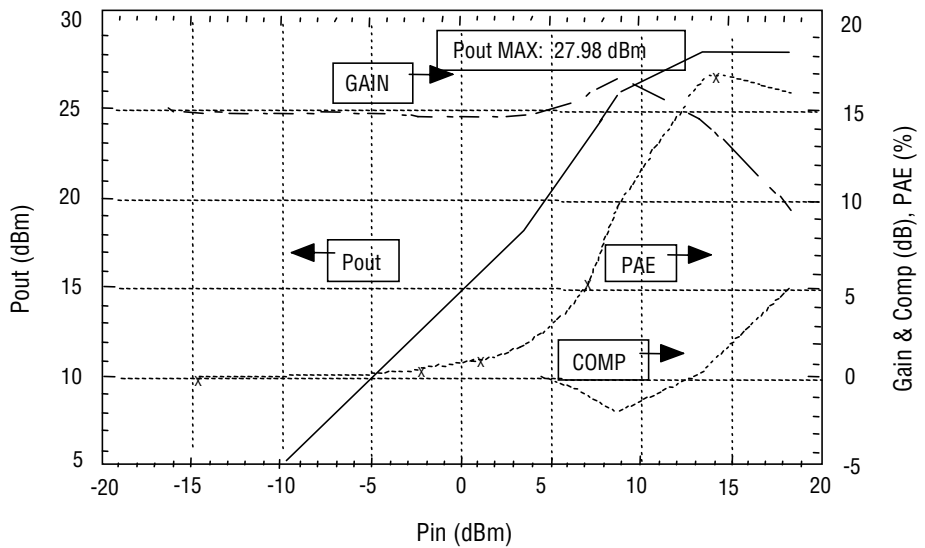

Characteristic performance data and specifications are subject to change without notice.