

# POWERLINE - DC/DC-Converter

# RECOM

E-Series, 40W, 1.6 kV Isolation, 2:1 Wide Input Range (Single, Dual & Triple Output)

## Features

- 40 Watts Output Power
- 2:1 Wide Input Voltage Range
- International Safety Standard Design
- Six-Sided Continuous Shield
- High Efficiency up to 90%
- Standard Package, 76.2 mm x 66.0 mm x 10.2 mm
- Fixed Switching Frequency

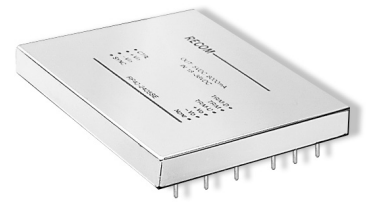

## Selection Guide 12V, 24V and 48V Input Types

Part Number	Input Voltage	Output Voltage	Output Current	Input Current (see note 6)	Efficiency (see note 7)	Capacitive Load max. $\mu$ F
	VDC	VDC	mA	mA	%	
RP40-123.3SE	9-18	3.3	10000	3530	83	25800
RP40-1205SE	9-18	5	8000	4170	84	13600
RP40-1212SE	9-18	12	3400	4100	87	2400
RP40-1215SE	9-18	15	2700	4100	87	1550
RP40-1205DE	9-18	$\pm$ 5	+7000 / -1000	4330	81	12000 / 1700
RP40-1212DE	9-18	$\pm$ 12	$\pm$ 1800	4550	83	$\pm$ 1200
RP40-1215DE	9-18	$\pm$ 15	$\pm$ 1400	4430	83	$\pm$ 750
RP40-123.305DE	9-18	3.3 / 5	4000 / 4000	3730	78	10300 / 6800
RP40-120512TE	9-18	5 / $\pm$ 12	4000 / $\pm$ 850	4490	79	6800 / $\pm$ 590
RP40-120515TE	9-18	5 / $\pm$ 15	4000 / $\pm$ 680	4430	80	6800 / $\pm$ 380
RP40-243.3SE	18-36	3.3	10000	1720	84	25800
RP40-2405SE	18-36	5	8000	2010	87	13600
RP40-2412SE	18-36	12	3400	1980	90	2400
RP40-2415SE	18-36	15	2700	2000	88	1550
RP40-2405DE	18-36	$\pm$ 5	+7000 / -1000	2130	82	12000 / 1700
RP40-2412DE	18-36	$\pm$ 12	$\pm$ 1800	2170	87	$\pm$ 1200
RP40-2415DE	18-36	$\pm$ 15	$\pm$ 1400	2140	86	$\pm$ 750
RP40-243.305DE	18-36	3.3 / 5	4000 / 4000	1840	79	10300 / 6800
RP40-240512TE	18-36	5 / $\pm$ 12	4000 / $\pm$ 850	2180	81	6800 / $\pm$ 590
RP40-240515TE	18-36	5 / $\pm$ 15	4000 / $\pm$ 680	2160	82	6800 / $\pm$ 380
RP40-483.3SE	36-75	3.3	10000	850	85	25800
RP40-4805SE	36-75	5	8000	980	89	13600
RP40-4812SE	36-75	12	3400	1000	89	2400
RP40-4815SE	36-75	15	2700	1000	88	1550
RP40-4805DE	36-75	$\pm$ 5	+7000 / -1000	1060	84	12000 / 1700
RP40-4812DE	36-75	$\pm$ 12	$\pm$ 1800	1100	86	$\pm$ 1200
RP40-4815DE	36-75	$\pm$ 15	$\pm$ 1400	1100	86	$\pm$ 750
RP40-483.305DE	36-75	3.3 / 5	4000 / 4000	910	80	10300 / 6800
RP40-480512TE	36-75	5 / $\pm$ 12	4000 / $\pm$ 850	1060	83	6800 / $\pm$ 590
RP40-480515TE	36-75	5 / $\pm$ 15	4000 / $\pm$ 680	1060	83	6800 / $\pm$ 380

# POWERLINE - DC/DC-Converter

# RECOM

E-Series, 40W, 1.6 kV Isolation, 2:1 Wide Input Range (Single, Dual & Triple Output)

## RP40-4805SE: Derating & Efficiency Curves

RP40-4805SE Derating Curve

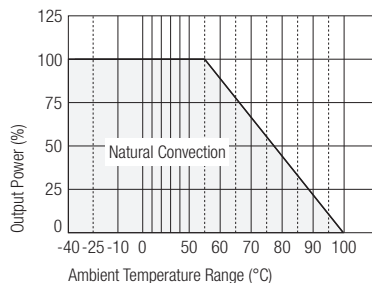

RP40-4805SE Efficiency vs Input Voltage

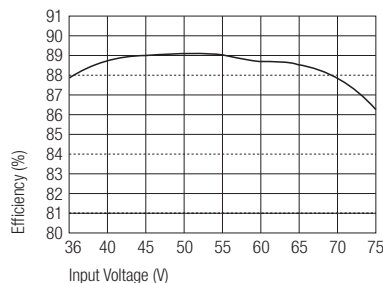

RP40-4805SE Efficiency vs Output Load

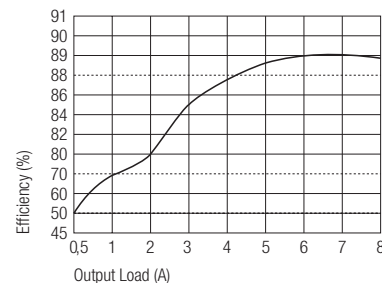

## Specifications (typical at nominal input and 25°C unless otherwise noted)

Output Power		40W max.
Voltage Accuracy (full Load and nominal Vin)	Single & Dual Triple 3.3V / 5V Auxiliary	±2% ±2% ±5%
Voltage Adjustability		± 10%
Minimum Load (see note 1)	RP40-xx3.305DE 3.3V output Others	20% min. 10% of full load
Line Regulation (LL-HL at FL)	Single (Dual) Triple 3.3V / 5V Auxiliary	±0.5% (±1%) ±2% ±5%
Load Regulation (10% to 100% FL)	Single Dual Triple 3.3V / 5V Auxiliary	±0.5% ±1% ±2% ±5%
Cross Regulation (see note 2)	Dual Triple 3.3V / 5V Auxiliary	±1% ±1% ±5%
Ripple and Noise (20MHz BW)		1% pk-pk of Vout
Temperature Coefficient		±0.02%/°C max.
Transient Response Recovery Time (25% load step change)		500µsec
Over Voltage (zener diode clamp)	3.3V output 5V output 12V output 15V output	3.9V 6.2V 15V 18V
Short Circuit Protection		Hiccup, Automatic Recovery
Input Voltage Range	12V types nominal input 24V types nominal input 48V types nominal input	9-18VDC 18-36VDC 36-75VDC
Input Filter		Pi Type
Input Surge Voltage (100 ms max.)	12V input 24V input 48V input	36VDC 50VDC 100VDC
Input Reflected Ripple (see note 3)	Nominal Vin	40mA <sub>p-p</sub>

continued on next page

# POWERLINE - DC/DC-Converter

# RECOM

E-Series, 40W, 1.6 kV Isolation, 2:1 Wide Input Range (Single, Dual & Triple Output)

## Specifications continued (typical at nominal input and 25°C unless otherwise noted)

Start Up Time (nominal Vin and constant resistor load)		25ms typ.
Remote ON/OFF (see note 4)	DC-DC ON DC-DC OFF	Open or $3.5V < V_r < 12V$ Short or $0V < V_r < 1.2V$
Remote Off Input Current		30mA
Efficiency		See „Selection Guide“ table“
Isolation Voltage		1600VDC
Isolation Resistance		$10^9 \Omega$
Isolation Capacitance		500pF
Switching Frequency		185kHz
Designed to Meet Safety Standard		UL 1950, EN60950
Case Material		Nickel-coated copper
Base Material		Non-conducted black FR4
Potting Material		Epoxy (UL94-V0)
Weight		125g
Dimensions		70.2 x 66.0 x 10.2 mm
MTBF (see note 5)		$1.590 \times 10^6$ Hours
Operating Temperature Range		-40°C to +85°C (with derating)
Maximum Case Temperature		+100°C
Storage Temperature Range		-55°C to +105°C
Thermal Impedance	Natural convection	5.7°C/Watt
Thermal Shock		MIL-STD-810D
Vibration		10-55Hz, 2G, 30 Min. along X, Y and Z
Relative Humidity		5% to 95% RH
Conducted Emissions	EN55022	Level A
Radiated Emissions	EN55022	Level A
Conducted Immunity	EN61000-4-6	Perf. Criteria 2
Radiated Immunity	EN61000-4-3	Perf. Criteria 2
Surge	EN61000-4-5	Perf. Criteria 2
Fast Transient	EN61000-4-4	Perf. Criteria 2
ESD	EN61000-4-2	Perf. Criteria 2

### Notes:

1. The RP40 E-series requires a minimum of 10% loading on the output to maintain specified regulation. Operation under no-load condition will not damage these devices, however they may not meet all listed specification.
2. Cross regulation: Dual output-Asymmetrical load 25% to 100% full load.  
Triple output - 3.3V/ 5V 100% load and one of auxiliary 100% load, other auxiliary load change from 25% to 100% load.
3. Simulated source impedance of 12uH. 12uH inductor in series with +Vin.
4. The ON-OFF control pin voltage is reference to negative input.
5. BELLCORE TR-NWT-000332. Case 1: 50% Stress, Temperature at 40 °C (ground fixed and controlled environment).
6. Maximum value at nominal input voltage and full load.
7. Typical value at nominal input voltage and full load.

# POWERLINE - DC/DC-Converter

E-Series, 40W, 1.6 kV Isolation, 2:1 Wide Input Range (Single, Dual & Triple Output)

**RECOM**

## Package Style and Pinning (mm)

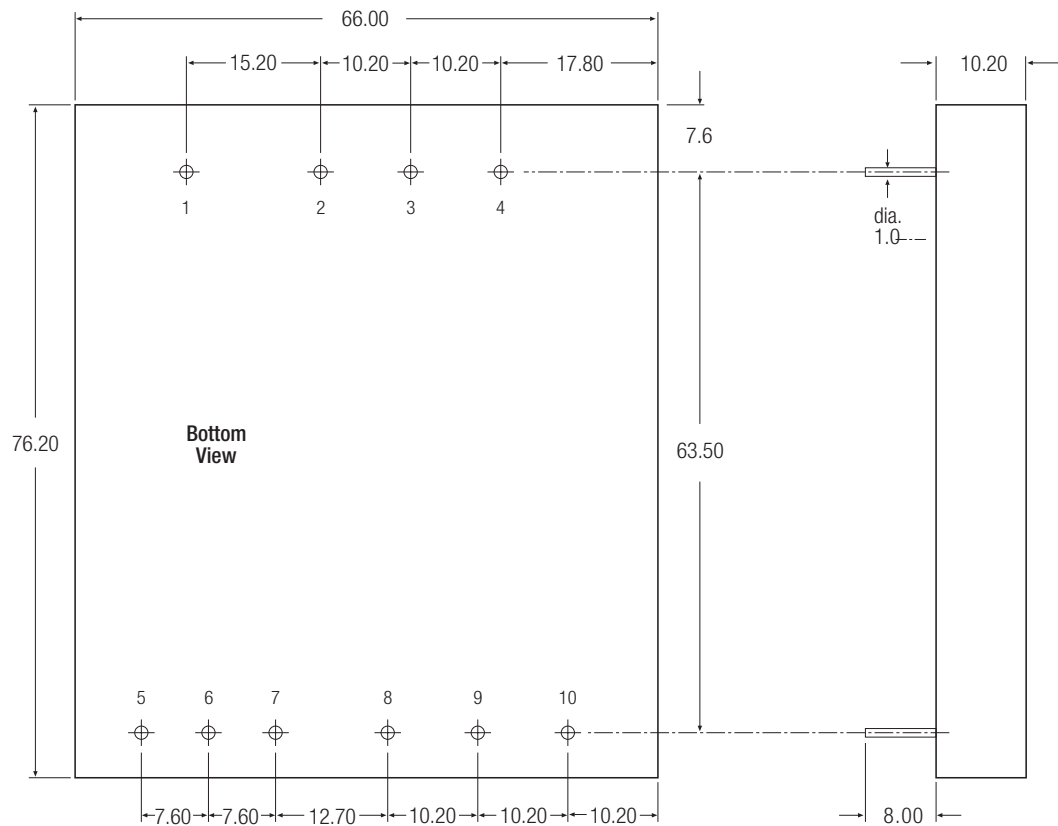

### Pin Connections

Pin #	Single	Dual	Triple	3.5V / 5V
1	Ctrl	Ctrl	Ctrl	Ctrl
2	+Vin	+Vin	+Vin	+Vin
3	-Vin	-Vin	-Vin	-Vin
4	Sync	Sync	Sync	Sync
5	Trim Down	+Vout	+Aux	+3.3V
6	Trim	Common	Common (Aux)	Common
7	Trim Up	-Vout	-Aux	+5V
8	+Vout	Trim	+Vout	Trim
9	-Vout	NC	-Vout	NC
10	No Pin	NC	Trim	NC

Pin Pitch Tolerance  $\pm 0.35$  mm

## External Output Trimming

Single	Dual	Triple	3.3V / 5V
7	7	9	6
6	8	10	8
5	5	8	5

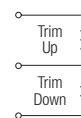

## Application of Synchronization

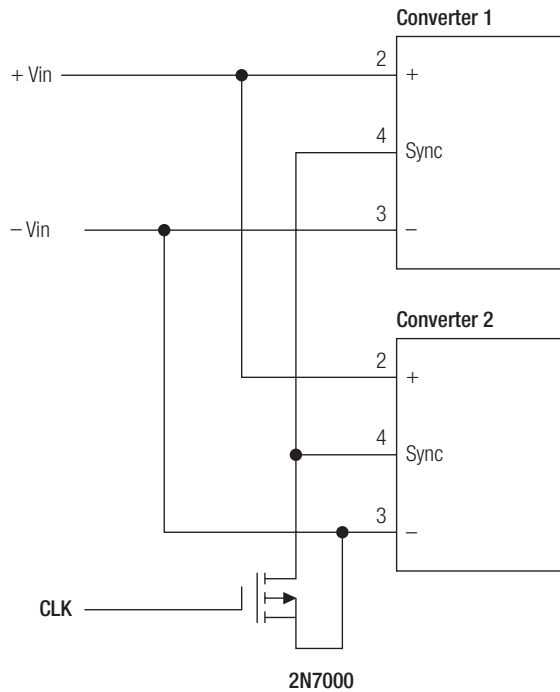

1. The unit is capable of external synchronization from an independent time base with a switching rate between 200kHz and 215 kHz.
2. The amplitude of the synchronizing pulse train is TTL compatible.
3. The duty cycle of the CLK should be 20% high and 80% low.
4. Synchronization is referenced to negative input (-Vin).

