

**FAST RECOVERY RECTIFIER**

**VOLTAGE RANGE 1000 to 1800 Volts CURRENT 1.0 Ampere**

**FEATURES**

- \* Fast switching
- \* Low leakage
- \* Low forward voltage drop
- \* High current capability
- \* High current surge
- \* High reliability

**MECHANICAL DATA**

- \* Case: Molded plastic
- \* Epoxy: UL 94V-O rate flame retardant
- \* Lead: MIL-STD-202E method 208C guaranteed
- \* Mounting position: Any
- \* Weight: 0.19 gram

**MAXIMUM RATINGS AND ELECTRICAL CHARACTERISTICS**

Ratings at 25 °C ambient temperature unless otherwise specified.  
 Single phase, half wave, 60 Hz, resistive or inductive load.  
 For capacitive load, derate current by 20%.

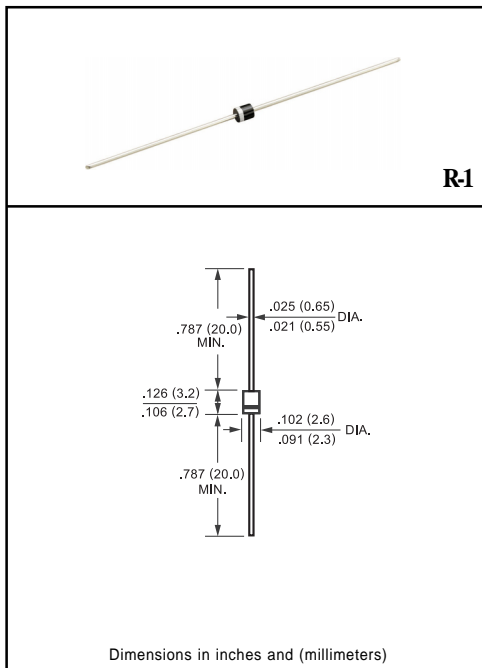

**MAXIMUM RATINGS** (At TA = 25°C unless otherwise noted)

RATINGS	SYMBOL	1F10	1F12	1F14	1F15	1F16	1F18	UNITS
Maximum Recurrent Peak Reverse Voltage	VRRM	1000	1200	1400	1500	1600	1800	Volts
Maximum RMS Voltage	VRMS	700	840	980	1050	1120	1260	Volts
Maximum DC Blocking Voltage	VDC	1000	1200	1400	1500	1600	1800	Volts
Maximum Average Forward Rectified Current at TA = 25°C	Io	0.5						Amps
Peak Forward Surge Current 8.3 ms single half sine-wave superimposed on rated load (JEDEC method)	IFSM	25						Amps
Typical Junction Capacitance (Note 2)	CJ	15						pF
Operating and Storage Temperature Range	TJ, TSTG	-65 to + 150						°C

**ELECTRICAL CHARACTERISTICS** (At TA = 25°C unless otherwise noted)

CHARACTERISTICS	SYMBOL	1F10	1F12	1F14	1F15	1F16	1F18	UNITS
Maximum Instantaneous Forward Voltage at 0.5A DC	VF	1.8						Volts
Maximum DC Reverse Current at Rated DC Blocking Voltage TA = 25°C	IR	5.0						uAmps
Maximum Full Load Reverse Current Full Cycle Average, .375" (9.5mm) lead length at TL = 55°C		100						uAmps
Maximum Reverse Recovery Time (Note 1)	trr	300						nSec

NOTES : 1. Reverse Recovery Test Conditions: IF = 0.5A, IR = 1.0A, IRR = 0.25A  
 2. Measured at 1 MHz and applied reverse voltage of 4.0 volts

# RATING AND CHARACTERISTIC CURVES ( 1F10 THRU 1F18 )

FIG. 1 - TYPICAL FORWARD CURRENT DERATING CURVE

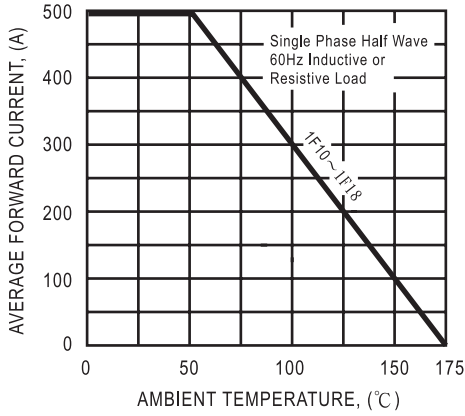

FIG. 2 - MAXIMUM NON-REPETITIVE FORWARD SURGE CURRENT

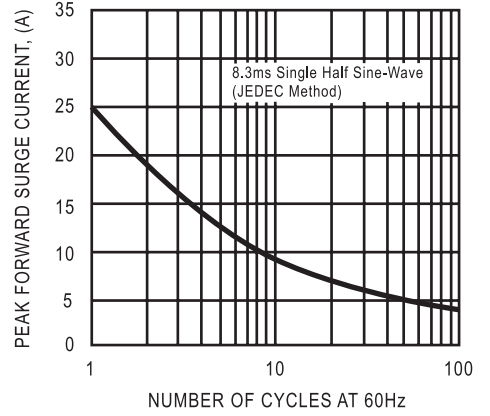
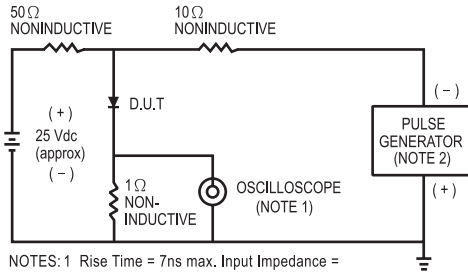

FIG. 3 - TEST CIRCUIT DIAGRAM AND REVERSE RECOVERY TIME CHARACTERISTIC



- NOTES: 1. Rise Time = 7ns max. Input Impedance = 1 megohm. 22 pF.  
 2. Rise Time = 10ns max. Source Impedance = 50 ohms.

