

**SINGLE-PHASE GLASS PASSIVATED
SILICON BRIDGE RECTIFIER**

VOLTAGE RANGE 50 to 1000 Volts CURRENT 15 Amperes

FEATURES

- * Superior thermal desing
- * 300 amperes surge rating
- * 1/4" universal faston terminal
- * Hole thru for # 10 screw

MECHANICAL DATA

- * UL listed the recognized component directory, file #E94233
- * Epoxy: Device has UL flammability classification 94V-O



MP-15



MP-15W

MAXIMUM RATINGS AND ELECTRICAL CHARACTERISTICS

Ratings at 25 °C ambient temperature unless otherwise specified.
Single phase, half wave, 60 Hz, resistive or inductive load.
For capacitive load, derate current by 20%.

MAXIMUM RATINGS (At TA = 25°C unless otherwise noted)

RATINGS	SYMBOL	MP1505	MP151	MP152	MP154	MP156	MP158	MP1510	UNITS
Maximum Recurrent Peak Reverse Voltage	VRRM	50	100	200	400	600	800	1000	Volts
Maximum RMS Bridge Input Voltage	VRMS	35	70	140	280	420	560	700	Volts
Maximum DC Blocking Voltage	VDC	50	100	200	400	600	800	1000	Volts
Maximum Average Forward Output Current at Tc = 55°C	Io	15.0							Amps
Peak Forward Surge Current 8.3 ms single half sine-wave superimposed on rated load (JEDEC method)	IFSM	300							Amps
Operating and Storage Temperature Range	TJ,TSTG	-55 to + 175							°C

ELECTRICAL CHARACTERISTICS (At TA = 25°C unless otherwise noted)

CHARACTERISTICS	SYMBOL	MP1505	MP151	MP152	MP154	MP156	MP158	MP1510	UNITS
Maximum Forward Voltage Drop per element at 7.5A DC	VF	1.1							Volts
Maximum Reverse Current at Rated	IR	10							uAmps
DC Blocking Voltage per element		0.5							mAmps

NOTE: Suffix "W" for wire type

RATING AND CHARACTERISTIC CURVES (MP1505 THRU MP1510)

FIG. 1 - MAXIMUM NON-REPETITIVE FORWARD SURGE CURRENT

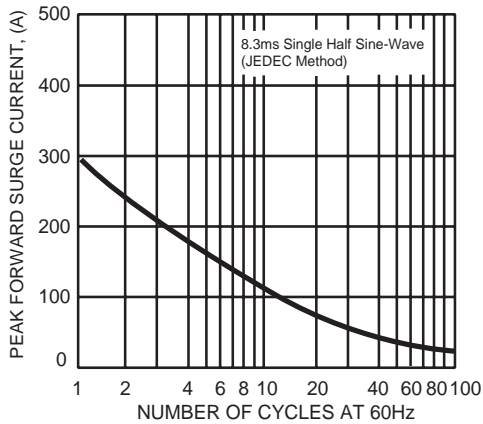

FIG. 2 - TYPICAL FORWARD CURRENT DERATING CURVE

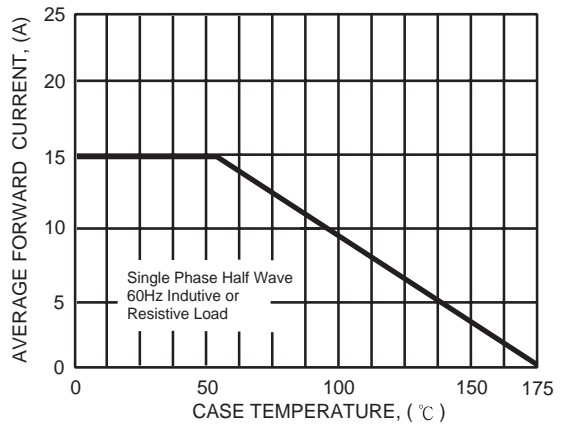

FIG. 3 - TYPICAL INSTANTANEOUS FORWARD CHARACTERISTICS

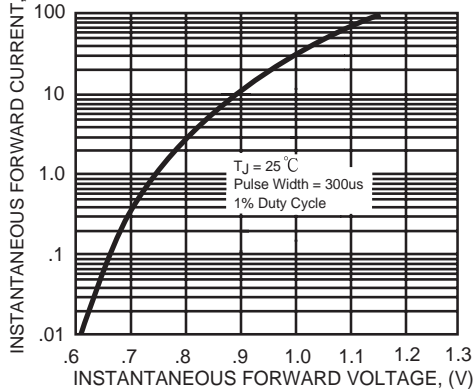
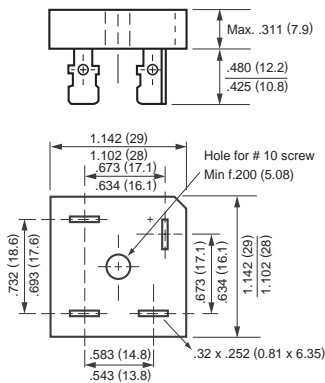
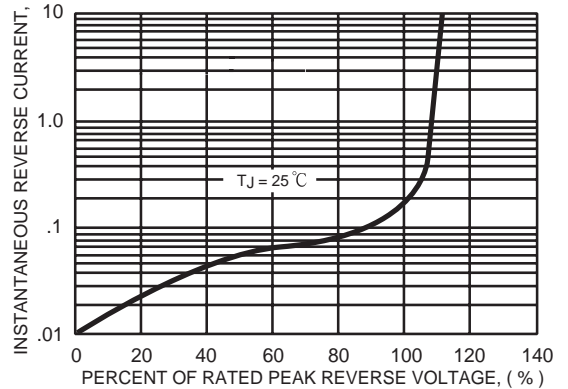
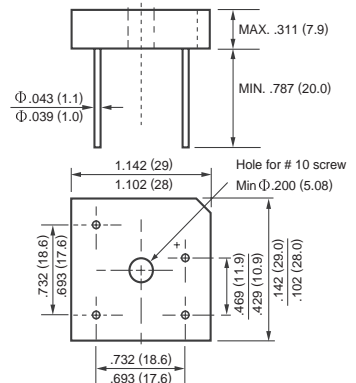

FIG. 4 - TYPICAL REVERSE CHARACTERISTICS



MP-15



MP-15W