

Typical Applications

- CDMA Cellular Handsets
- TDMA Cellular Handsets

Product Description

The RF2376 is a linear variable gain amplifier suitable for use in TDMA and CDMA systems in the cellular band. The features of this device include linear gain control, high gain, and low noise figure. The IC is manufactured on an advanced Gallium Arsenide Heterojunction Bipolar Transistor (GaAs HBT) process and is featured in an industry-standard miniature 6-lead plastic SOT package.

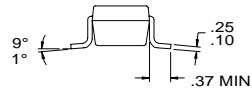
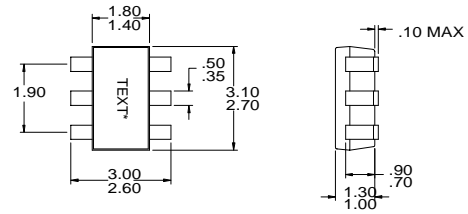

*When Pin 1 is in upper left, text reads downward (as shown).

All dimensions in mm.

Optimum Technology Matching® Applied

- | | | |
|-------------------------------------|--|--------------------------------------|
| <input type="checkbox"/> Si BJT | <input checked="" type="checkbox"/> GaAs HBT | <input type="checkbox"/> GaAs MESFET |
| <input type="checkbox"/> Si Bi-CMOS | <input type="checkbox"/> SiGe HBT | <input type="checkbox"/> Si CMOS |

Package Style: SOT23-6

- Features
- 50dB Linear Gain Control Range
 - 27dB Maximum Gain
 - Single 2.7V to 3.3V Supply
 - 30mA Supply Current
 - High Linearity
 - 7dB Noise Figure

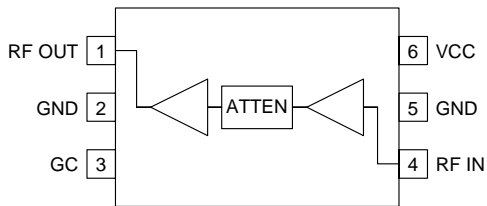

Functional Block Diagram

Ordering Information

RF2376	Cellular TDMA/CDMA Linear Variable Gain Amplifier
RF2376 PCBA	Fully Assembled Evaluation Board

RF Micro Devices, Inc.
7625 Thorndike Road
Greensboro, NC 27409, USA

Tel (336) 664 1233
Fax (336) 664 0454
<http://www.rfmd.com>

Absolute Maximum Ratings

Parameter	Rating	Unit
Supply Voltage	0 to +5.0	V _{DC}
DC Current	100	mA
Operating Ambient Temperature	-20 to +85	°C
Storage Temperature	-40 to +150	°C



Caution! ESD sensitive device.

RF Micro Devices believes the furnished information is correct and accurate at the time of this printing. However, RF Micro Devices reserves the right to make changes to its products without notice. RF Micro Devices does not assume responsibility for the use of the described product(s).

Parameter	Specification			Unit	Condition
	Min.	Typ.	Max.		
Overall					V _{CC} =2.8V, V _{GC} =2.0V, T=25°C
Operating Frequency		836		MHz	
Usable Frequency Range		800 to >1000		MHz	
Maximum Small Signal Gain	24	27	30	dB	
Linear Gain Control Range	50			dB	
Gain Control Slope		70		dB/V	Maximum gain.
Input VSWR		1.5:1	2.5:1		Over entire gain control range
Output IP3	+22	+25		dBm	
Noise Figure		7		dB	Maximum gain
Maximum Average Output Power		+8		dBm	TDMA modulation
Adjacent Channel Power Rejection		-33	-32	dBc	TDMA modulation; P _{OUT} =+8dBm
Alternate Channel Power Rejection		-61	-57	dBc	TDMA modulation; P _{OUT} =+8dBm
Maximum Average Output Power		+10		dBm	CDMA modulation; V _{CC} =3.0V, maximum gain setting, ACPR _≤ -52dBc.
Adjacent Channel Power Rejection		-53		dBc	CDMA modulation; V _{CC} =3.0V. For P _{IN} >-23dBm, adjustment of P _{IN} is required to maintain ACPR performance over gain control range. For P _{IN} ≤-23dBm, ACPR performance is maintained over entire gain control range.
Alternate Channel Power Rejection		-67		dBc	CDMA modulation; P _{OUT} =+10dBm, V _{CC} =3.0V.
Power Supply					T = 25°C
Supply Voltage		2.8		V	Specifications
		2.7 to 3.3		V	Operating range
Gain Control Voltage		0 to 2.0		V	
Supply Current	25	30	40	mA	V _{CC} =2.8V, V _{GC} =2.0V
		34		mA	V _{CC} =3.0V, V _{GC} =2.0V
			18	mA	V _{CC} =2.8V, V _{GC} =0.4V
V _{GC} Current			1.5	mA	

Pin	Function	Description	Interface Schematic
1	RF OUT	RF output pin. This pin is DC coupled and requires V_{CC} through a bias inductor sized accordingly to provide a high pass transformation with a series capacitor.	
2	GND	Ground connection. Keep traces physically short and connect immediately to ground plane for best performance.	
3	GC	Analog gain control pin. This pin controls the gain of the IC. Minimum gain occurs at $V_{GC} < 0.4V$ and maximum gain is achieved with $V_{GC} = 2.0V$. 50dB of linear gain control with little variation of input P_{1dB} is available.	
4	RF IN	RF input pin. This pin is AC coupled.	
5	GND	Ground connection. Keep traces physically short and connect immediately to ground plane for best performance.	
6	VCC	Power supply. This pin should be connected to a regulated supply and requires a bypass capacitor. Voltage is supplied through this pin to the first stage collector; this voltage also controls the bias. Gain may be tuned by adjusting the value of the feed inductor.	

Application Schematic

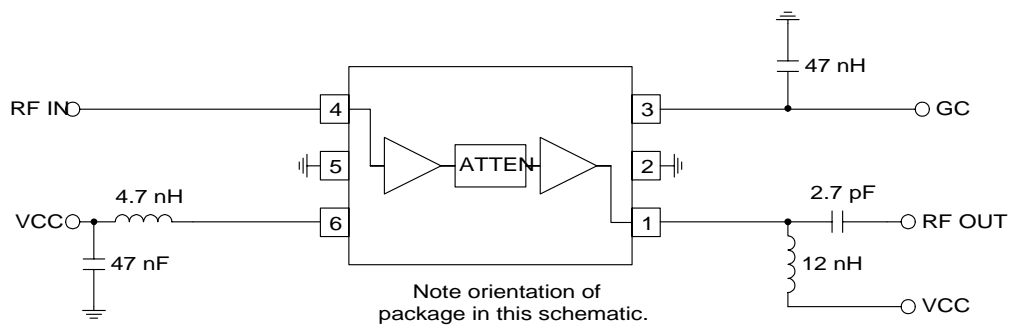

Evaluation Board Schematic

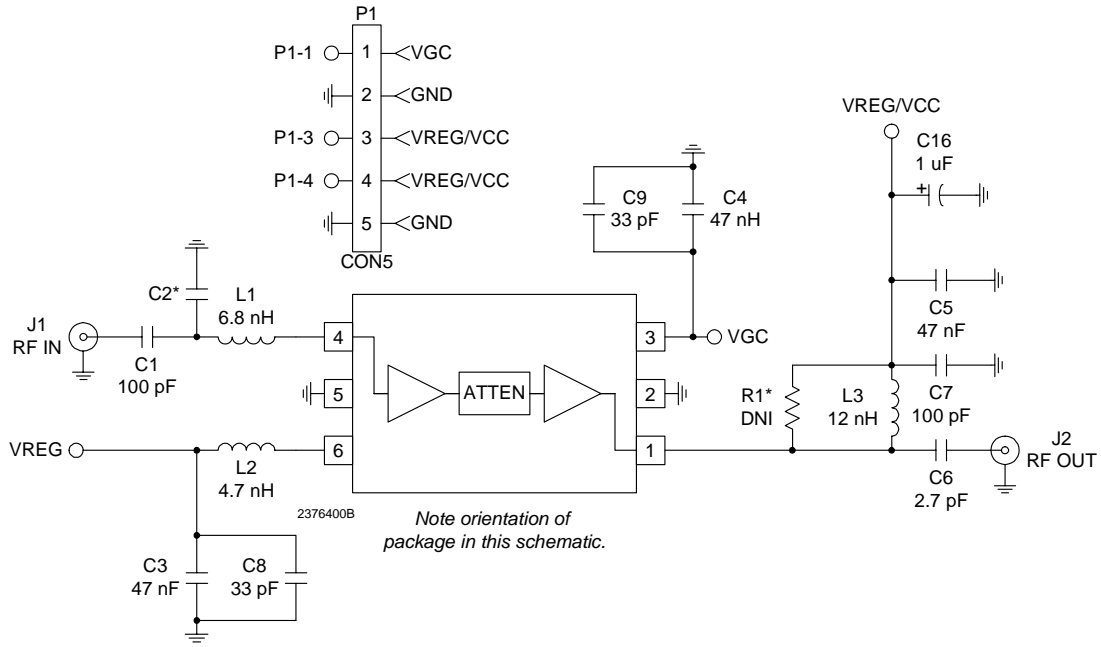

Evaluation Board Layout
Board Size 2.0" x 2.0"
Board Thickness 0.028"; Board Material FR-4

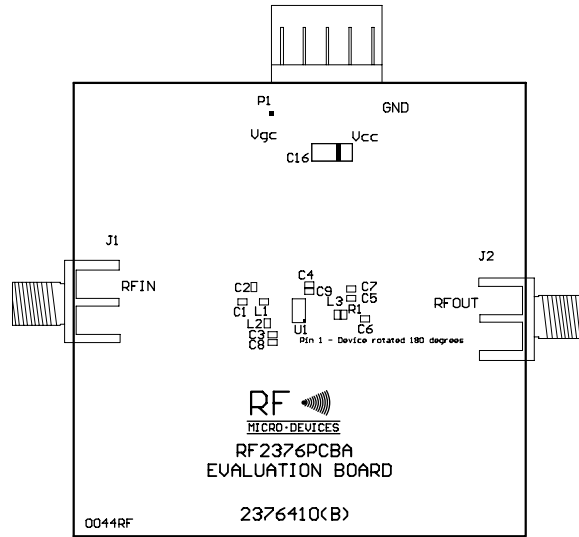

4
GENERAL PURPOSE
AMPLIFIERS

