

### Typical Applications

- Digital and Analog Communication Systems • GMSK, QPSK, DQPSK, QAM Modulation
- Spread-Spectrum Communication Systems • AM, SSB, DSB Modulation
- Portable Battery-Powered Equipment

### Product Description

The RF2423 is a monolithic integrated transmitter IC capable of universal direct modulation for UHF AM, PM, or compound carriers. The transmitter may be used stand-alone for applications requiring not more than 100mW output power, or may be used to drive a final power amplifier. The maximum output level is 100mW, and is adjustable over a 25dB range by a single positive voltage. This low-cost IC implements differential amplifiers for the modulation inputs, 90 degree carrier phase shift network, carrier limiting amplifiers, two matched doubly-balanced mixers, variable gain summing amplifier for level control, and 100mW linear (class AB) output amplifier.

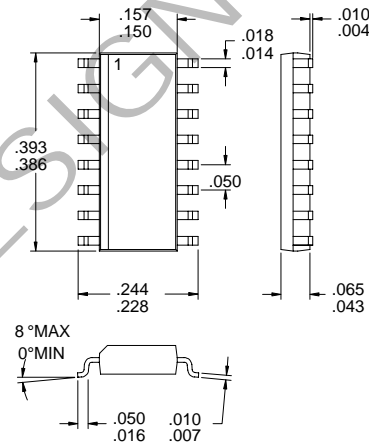

### Optimum Technology Matching® Applied

- |                                     |                                   |   |
|-------------------------------------|-----------------------------------|---|
| <input type="checkbox"/> Si BJT     | <input type="checkbox"/> GaAs HBT | <input checked="" type="checkbox"/> GaAs MESFET |
| <input type="checkbox"/> Si Bi-CMOS | <input type="checkbox"/> SiGe HBT | <input type="checkbox"/> Si CMOS                |

Package Style: SOP-16

### Features

- Single 5V Power Supply
- 100mW Output Power Into 50Ω
- 25dB Gain Control Range
- Excellent Phase & Amplitude Balance
- Digitally Controlled Stand-By Mode
- 800MHz to 1000MHz Operation

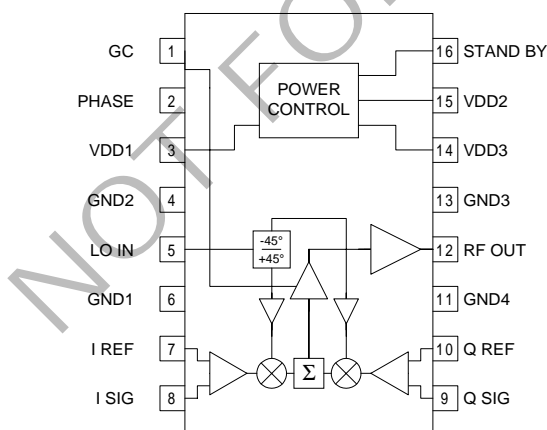

Functional Block Diagram

### Ordering Information

- |             |                                      |
|-------------|--------------------------------------|
| RF2423      | 100mW Spread-Spectrum Transmitter IC |
| RF2423 PCBA | Fully Assembled Evaluation Board     |

 RF Micro Devices, Inc.  
 7625 Thorndike Road  
 Greensboro, NC 27409, USA

 Tel (336) 664 1233  
 Fax (336) 664 0454  
<http://www.rfmd.com>

# RF2423

## Absolute Maximum Ratings

Parameter	Rating	Unit
Supply Voltage	-0.5 to +7.5	V <sub>DC</sub>
Power Down Voltage (V <sub>PD</sub> )	V <sub>DD</sub> +0.4	V <sub>DC</sub>
Input LO and RF Levels	+6	dBm
Operating Ambient Temperature	-40 to +85	°C
Storage Temperature	-40 to +150	°C



**Caution!** ESD sensitive device.

RF Micro Devices believes the furnished information is correct and accurate at the time of this printing. However, RF Micro Devices reserves the right to make changes to its products without notice. RF Micro Devices does not assume responsibility for the use of the described product(s).

Parameter	Specification			Unit	Condition
	Min.	Typ.	Max.		
<b>Carrier Input (LO IN)</b>					T=25 °C, V <sub>DD</sub> =5.3V, V <sub>GC</sub> =5.3V
Frequency Range		800 to 1000		MHz	
Power Level		0 to +6		dBm	
Input Impedance		55-j120		Ω	915MHz
<b>Modulation Input</b>					
Frequency Range		DC to 100		MHz	
Reference Voltage (V <sub>REF</sub> )		2.0 to 3.0		V	
Modulation for 100mW Output Power (I & Q)		V <sub>REF</sub> ±2		V	
Maximum Modulation (I & Q)		V <sub>REF</sub> ±2.5		V	
Quadrature Phase Error		±3		°	
Input Impedance		3000		Ω	
DC Offset (I & Q)		40	200	mV	
<b>RF Output</b>					V <sub>DD</sub> =5.3V, V <sub>GC</sub> =5.3V, LO power=0dBm, LO frequency=915MHz, SSB, I/Q=2.0V <sub>P</sub> sine wave, V <sub>REF</sub> =3V
Output Power	+22 -15	+22 -10	+5	dBm	
Output Impedance		50		Ω	V <sub>GAIN</sub> =0V
Output VSWR		2:1			
Second Harmonic Output		-45		dBc	
Other Harmonics Output		<-20		dBc	
Sideband Suppression	25	35		dB	
Carrier Suppression	22	30		dB	Modulation DC offset can be externally adjusted for optimum suppression. Carrier suppression is then typically better than 40dB.
<b>Output Level Control</b>					
Control Range		25		dB	
Control Voltage		1 to 4		V	
Control Input Current		<1.5		mA	
<b>Standby Mode</b>					
Turn On/Off Time		<100		ns	
STANDBY Input Impedance		>50		kΩ	
Power Down "ON"		V <sub>CC</sub>		V	Threshold voltage; Part is turned "ON"
Power Down "OFF"		0		V	Threshold voltage; Part is turned "OFF"
<b>Power Supply</b>					
Voltage		5		V	Specifications
		4.5 to 6.0		V	Operating limits
Current	60	110	170	mA	Total, 100mW output power
		50		mA	Total, minimum output power
		2	20	mA	Standby mode

Pin	Function	Description	Interface Schematic
1	GC	Gain control of the RF amplifier. This pin can be used to control the output power over a 25dB range. Output power is the lowest when the control voltage is 1V or lower, and the highest when set to 4V or higher. When a fixed maximum output level is needed, it is recommended to connect this pin to VDD.	
2	PHASE	This pin adjusts the phase of the I/Q signals. However, the control is very sensitive and hard to control. Control voltage change for a few degrees adjustment is in the order of 10mV. Device to device and temperature variation are not characterized. Therefore it is not recommended to use this pin; leave it not connected. Do NOT connect it to ground. For compensating large errors in the I/Q signals supplied to the device or in control loops, this pin may prove useful.	
3	VDD1	Power supply to all circuits except the RF output stages. It is recommended to put some RF decoupling on this pin, though it is not critical. An optional 0.1μF capacitor is required if no other low frequency bypass capacitor is nearby.	
4	GND2	Ground connection for the gain controlled RF amplifier. Keep traces physically short and connect immediately to ground plane for best performance.	
5	LO IN	Modulator LO input. A series 22nH inductor can be used for matching. This pin is NOT internally DC blocked. An external blocking capacitor must be provided if the pin is connected to a device with DC present. A DC path to ground (i.e. an inductor or resistor to ground) is, however, acceptable at this pin. If a blocking capacitor is required, a value of 33pF is recommended.	
6	GND1	Ground connection for the baseband, LO and mixer circuits. Keep traces physically short and connect immediately to ground plane for best performance.	
7	I REF	Reference voltage for the I mixer. This voltage should be the same as the DC voltage supplied to the I SIG pin. To obtain a carrier suppression of better than 25dB it may be tuned ±0.15V (relative to the I SIG DC voltage). Without tuning, it will typically be better than 25dB. Input impedance of this pin is about 3kΩ.	
8	I SIG	Baseband input to the I mixer. This pin is DC coupled. Maximum output power is obtained when the input signal has a peak to peak amplitude of 5V. The DC level supplied to this pin should be VDD2/2. Input impedance of this pin is about 3kΩ.	
9	Q SIG	Baseband input to the Q mixer. This pin is DC coupled. Maximum output power is obtained when the input signal has a peak to peak amplitude of 5V. The DC level supplied to this pin should be VDD2/2. Input impedance of this pin is about 3kΩ.	
10	Q REF	Reference voltage for the Q mixer. This voltage should be the same as the DC voltage supplied to the Q SIG pin. To obtain a carrier suppression of better than 25dB it may be tuned ±0.15V (relative to the Q SIG DC voltage). Without tuning it will typically be better than 25dB. Input impedance of this pin is about 3kΩ.	

# RF2423

Pin	Function	Description	Interface Schematic
11	<b>GND4</b>	Ground connection for the RF driver and output stage. Keep traces physically short and connect immediately to ground plane for best performance. Having a good ground connection on this pin is extremely important due to the high RF levels in the circuits connected to this pin.	
12	<b>RF OUT</b>	50Ω RF output. This pin is not internally DC blocked and an external blocking capacitor of 22pF is needed.	
13	<b>GND3</b>	Ground connection for the RF driver and output stage. Keep traces physically short and connect immediately to ground plane for best performance. Having a good ground connection on this pin is extremely important due to the high RF levels in the circuits connected to this pin.	
14	<b>VDD3</b>	Power supply for the RF output stage. A 33pF external bypass capacitor is required and an optional 0.1 μF will be required if no other low frequency bypass capacitors are nearby. The trace length between the pin and the bypass capacitors should be minimized. The ground side of the bypass capacitors should connect immediately to ground plane. Having good bypassing on this pin is especially important because of the high levels of RF signal on the circuits connected to this pin.	
15	<b>VDD2</b>	Power supply for the RF driver stage. A 33pF external bypass capacitor is required and an optional 0.1 μF will be required if no other low frequency bypass capacitors are near by. The trace length between the pin and the bypass capacitors should be minimized. The ground side of the bypass capacitors should connect immediately to ground plane. Having good bypassing on this pin is especially important because of the high levels of RF signal on the circuits connected to this pin.	
16	<b>STANDBY</b>	Standby mode control. When this pin is 0V all circuits are turned off, and when this pin is VDD all circuits are operating. This is a high impedance input, internally connected to the gate of a few transistors. To minimize current consumption in power down mode, this pin should be as close to 0 V as possible, or even a little negative. Turn-on voltage of some parts of the circuit may be as low as 0.0 V. In order to maximize output power this pin should be as close to VDD as possible during normal operation.	

## Application Schematic

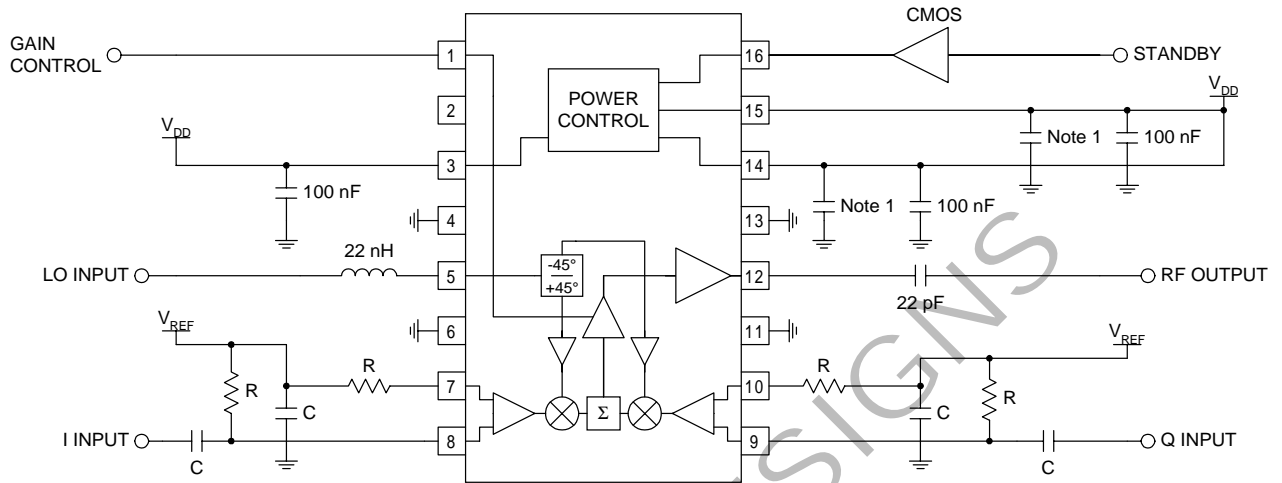

NOTE 1: 33 pF SMD capacitor mounted as close to the package pin as possible, grounded through via to the ground plane with minimum inductance.

NOTE 2: The values of R and C depend on the lowest frequency of the baseband signal.

# RF2423

## Evaluation Board Schematic (Download [Bill of Materials](http://www.rfmd.com) from [www.rfmd.com](http://www.rfmd.com).)

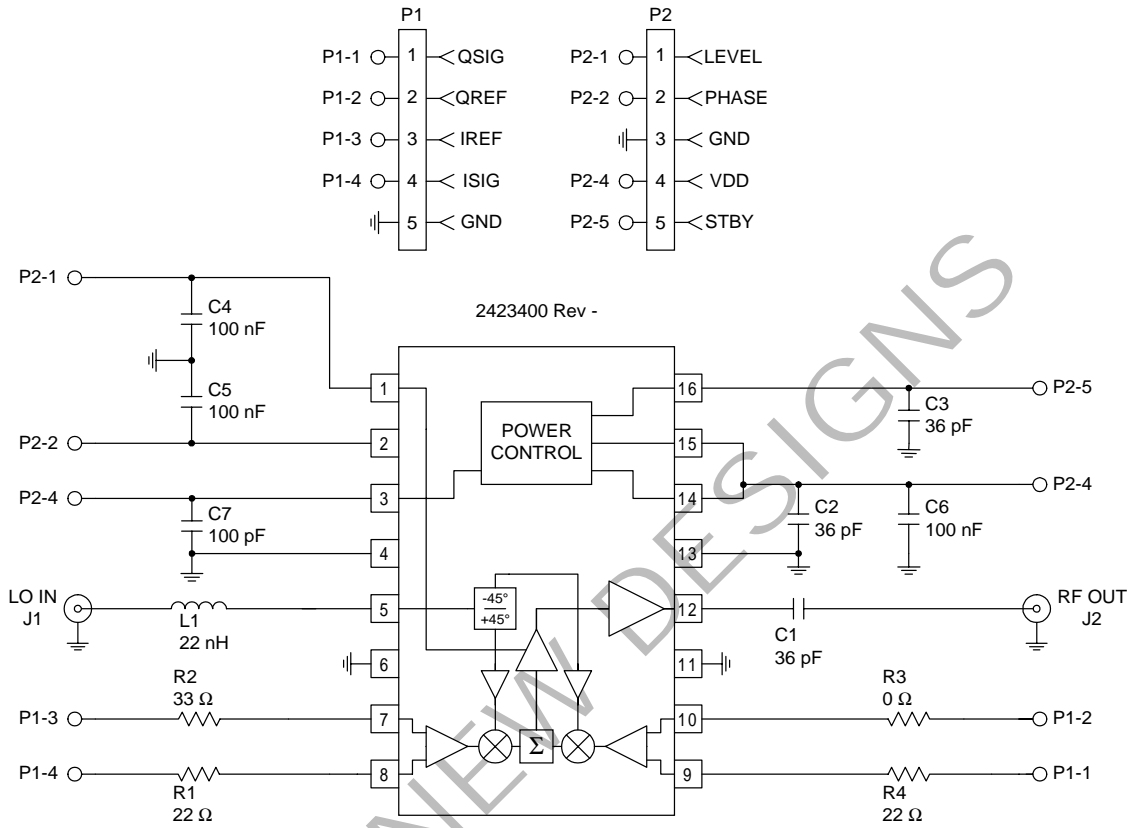

Evaluation Board Layout  
1.25" x 1.25"  
Board Thickness 0.031"; Board Material FR-4

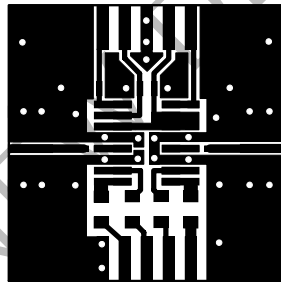
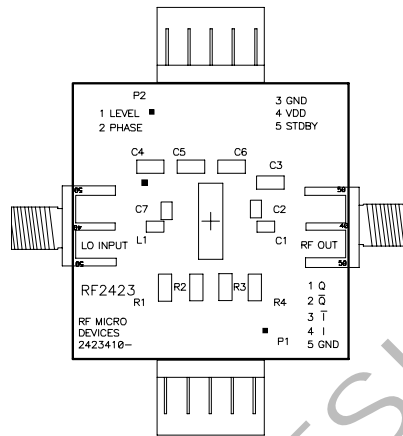

**RF2423**

**5**

**MODULATORS AND  
UPCONVERTERS**

NOT FOR NEW DESIGNS