

Typical Applications

- Digital Communications Systems
- Spread Spectrum Communication Systems
- GSM, QPSK, DQPSK, QAM Modulation
- GSM and D-AMPS Systems
- AM, SSB, DSB Modulation
- Image-Reject Upconverters

Product Description

The RF2424 is a monolithic integrated quadrature modulator IC capable of universal direct modulation for high-frequency AM, PM, or compound carriers. Maximum output power is +7.5dBm, which is achieved with low input I and Q signal levels. This low-cost IC implements differential amplifiers for the modulation inputs, 90° carrier phase shift network, carrier limiting amplifiers, two matched double-balanced mixers, summing amplifier, and an output RF amplifier which will drive 50Ω from 700MHz to 1000MHz.

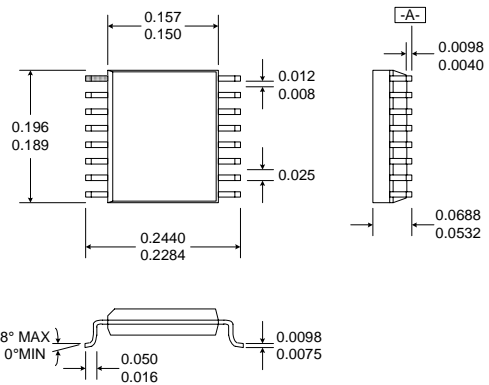

- NOTES:**
1. Shaded lead is Pin 1.
 2. All dimensions are excluding mold flash.
 3. Lead coplanarity - 0.005 with respect to datum "A".

5
MODULATORS AND UPCONVERTERS

Optimum Technology Matching® Applied

- Si BJT GaAs HBT GaAs MESFET
 Si Bi-CMOS SiGe HBT Si CMOS

Package Style: SSOP-16

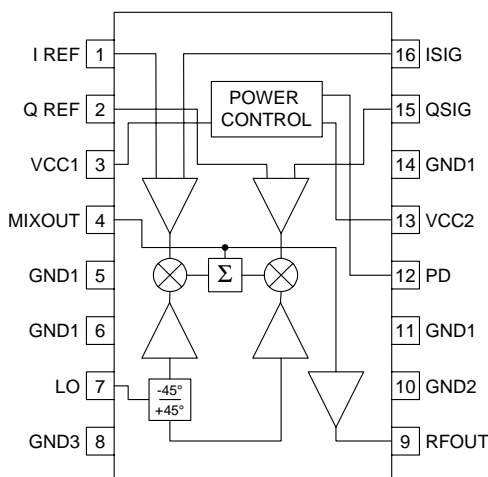

Functional Block Diagram

Features

- Single 2.7V to 5.5V Power Supply
- +7.5dBm Output Power
- No Tuning Required
- Low LO Input Level
- Digitally Controlled Power Down Mode
- 700MHz to 1000MHz Operation

Ordering Information

- RF2424 UHF Quadrature Modulator
 RF2424 PCBA Fully Assembled Evaluation Board

RF Micro Devices, Inc.
 7628 Thorndike Road
 Greensboro, NC 27409, USA

Tel (336) 664 1233
 Fax (336) 664 0454
<http://www.rfmd.com>

RF2424

Absolute Maximum Ratings

| Parameter | Rating | Unit |
|-------------------------------|-------------|-----------------|
| Supply Voltage | 5.5 | V _{DC} |
| Input LO and RF Levels | +6.0 | dBm |
| Operating Ambient Temperature | -40 to +85 | °C |
| Storage Temperature | -40 to +150 | °C |



Caution! ESD sensitive device.

RF Micro Devices believes the furnished information is correct and accurate at the time of this printing. However, RF Micro Devices reserves the right to make changes to its products without notice. RF Micro Devices does not assume responsibility for the use of the described product(s).

| Parameter | Specification | | | Unit | Condition |
|---------------------------------------|---------------|------------------------|------|--------|--|
| | Min. | Typ. | Max. | | |
| Carrier Input | | | | | T=25 °C, V _{CC} =3V |
| Frequency Range | 700 | | 1000 | MHz | |
| Power Level | -6 | | +6 | dBm | |
| Input impedance | | 43 + j1.8 | | Ω | At 900MHz |
| Modulation Input | | | | | |
| Frequency Range | DC | | 100 | MHz | |
| Reference Voltage (V _{REF}) | | 1.6 | | V | |
| Maximum Modulation (I&Q) | | V _{REF} ± 0.3 | | V | |
| Gain Asymmetry | | 0.2 | | dB | |
| Quadrature Phase Error | | 1 | | ° | |
| Input DC Resistance | | 40 | | kΩ | |
| Input Bias Current | | 40 | | μA | |
| RF Output | | | | | V _{CC} =3V, LO power=-3dBm, LO freq=900MHz, I/Q drive level=0.2V _p , SSB |
| Output Power | +5.0 | +7.5 | | dBm | |
| Output Impedance | | 50 | | Ω | |
| Broadband Noise Floor | | -140 | | dBm/Hz | |
| Sideband Suppression | 25 | 35 | | dB | |
| Carrier Suppression | 25 | 30 | | dB | |
| IM ₃ Suppression | 25 | 30 | | dB | DSB output (+9dBm total power) |
| Power Down | | | | | |
| Turn On/Off Time | | | 100 | ns | |
| PD Input Resistance | 10 | | | kΩ | |
| Power Down "ON" | | V _{CC} | | V | |
| Power Down "OFF" | 1.0 | 1.2 | | V | |
| Power Supply | | | | | |
| Voltage | 2.7 | | 5.5 | V | |
| Current | | 45 | 55 | mA | V _{CC} =3V |
| | | 53 | | mA | V _{CC} =5V |
| Power Down | | | 10 | μA | |

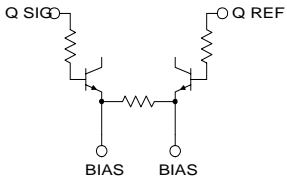
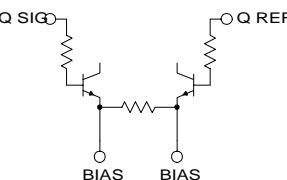
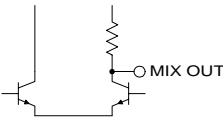
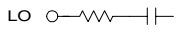
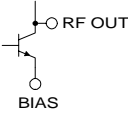
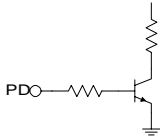
| Pin | Function | Description | Interface Schematic |
|-----|----------|--|---|
| 1 | I REF | Reference voltage for the I mixer. This voltage should be the same as the DC voltage supplied to the I SIG pin. A voltage of 1.6V is recommended. The SIG and REF inputs are inputs of a differential amplifier. Therefore the REF and SIG inputs are interchangeable. If swapping the I SIG and I REF pins, the Q SIG and Q REF also need to be swapped to maintain the correct phase. It is also possible to drive the SIG and REF inputs in a balanced mode. If single ended operation is desired then the input is applied to I SIG, pin 16. In that case, I REF and Q REF are tied together and AC coupled to ground. To obtain a carrier suppression of better than 40dB, I REF may be tuned $\pm 20\text{mV}$ relative to the I SIG. Without tuning, it will typically be better than 25dB. |  |
| 2 | Q REF | Reference voltage for the Q mixer. This voltage should be the same as the DC voltage supplied to the Q SIG pin. A voltage of 1.6V is recommended. The SIG and REF inputs are inputs of a differential amplifier. Therefore the REF and SIG inputs are interchangeable. If swapping the Q SIG and Q REF pins, the I SIG and I REF also need to be swapped to maintain the correct phase. It is also possible to drive the SIG and REF inputs in a balanced mode. If single ended operation is desired then the input is applied to Q SIG, pin 15. In that case, Q REF and Q REF are tied together and AC coupled to ground. To obtain a carrier suppression of better than 40dB, Q REF may be tuned $\pm 20\text{mV}$ relative to the Q SIG. Without tuning, it will typically be better than 25dB. |  |
| 3 | VCC1 | Power supply for the I mixer, Q mixer and the RF Output amplifier. | |
| 4 | MIX OUT | MIXOUT: Combined output of the I mixer and Q mixer. By changing the inductor value, maximum RF output is tuned to different frequency. If the inductor value is changed, the RF output match needs to be adjusted for 50Ω output impedance. |  |
| 5 | GND1 | Ground connection for the LO and baseband amplifiers and mixers. | |
| 6 | GND1 | Same as pin 5. | |
| 7 | LO IN | The input of the phase shifting network. |  |
| 8 | GND3 | Ground connection for the LO phase shift network. | |
| 9 | RF OUT | RF Output. An external LC matching network is needed for a 50Ω match. |  |
| 10 | GND2 | Ground connection for the RF output stage. | |
| 11 | GND1 | Same as pin 5. | |
| 12 | PD | Power Down control. When this pin is "low", all circuits are shut off. |  |
| 13 | VCC2 | Power supply for all circuits except mixers and output amplifier. | |
| 14 | GND1 | Same as pin 5. | |
| 15 | Q SIG | Baseband input to the Q mixer. Maximum output power is obtained when the input signal has a peak to peak amplitude of 400mV. The DC level for this pin is 1.6V, same as QREF. | See pin 2. |
| 16 | I SIG | Baseband input to the Q mixer. Maximum output power is obtained when the input signal has a peak to peak amplitude of 400mV. The DC level for this pin is 1.6V, same as QREF. | See pin 1. |

RF2424

Application Schematic

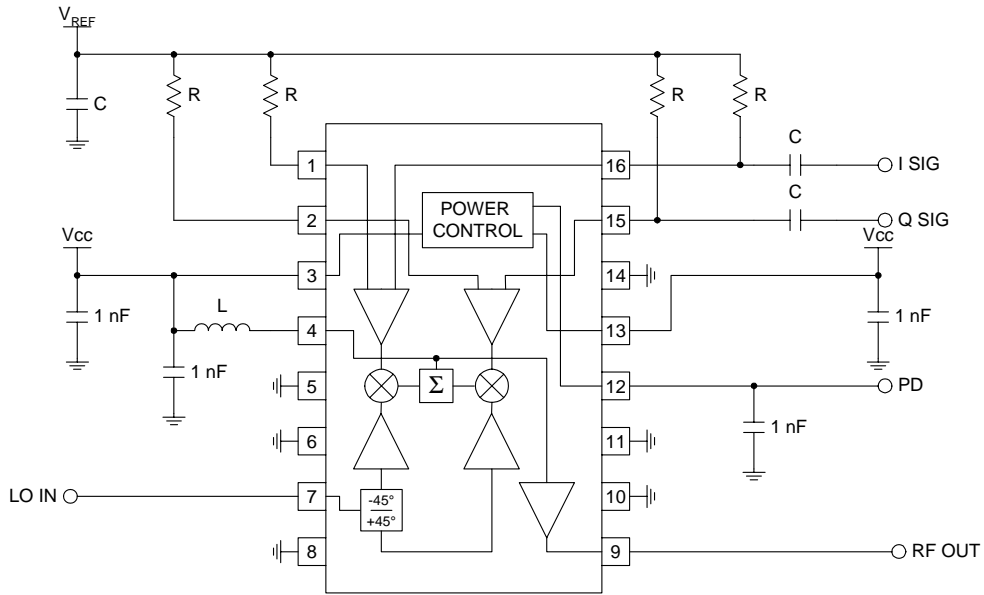

NOTE:
The values of R and C depend on the minimum baseband frequency (i.e., the cutoff frequency of this high pass filter should be lower than the lowest frequency component in the I/Q spectrum).

Evaluation Board Schematic (Download [Bill of Materials](http://www.rfmd.com) from www.rfmd.com.)

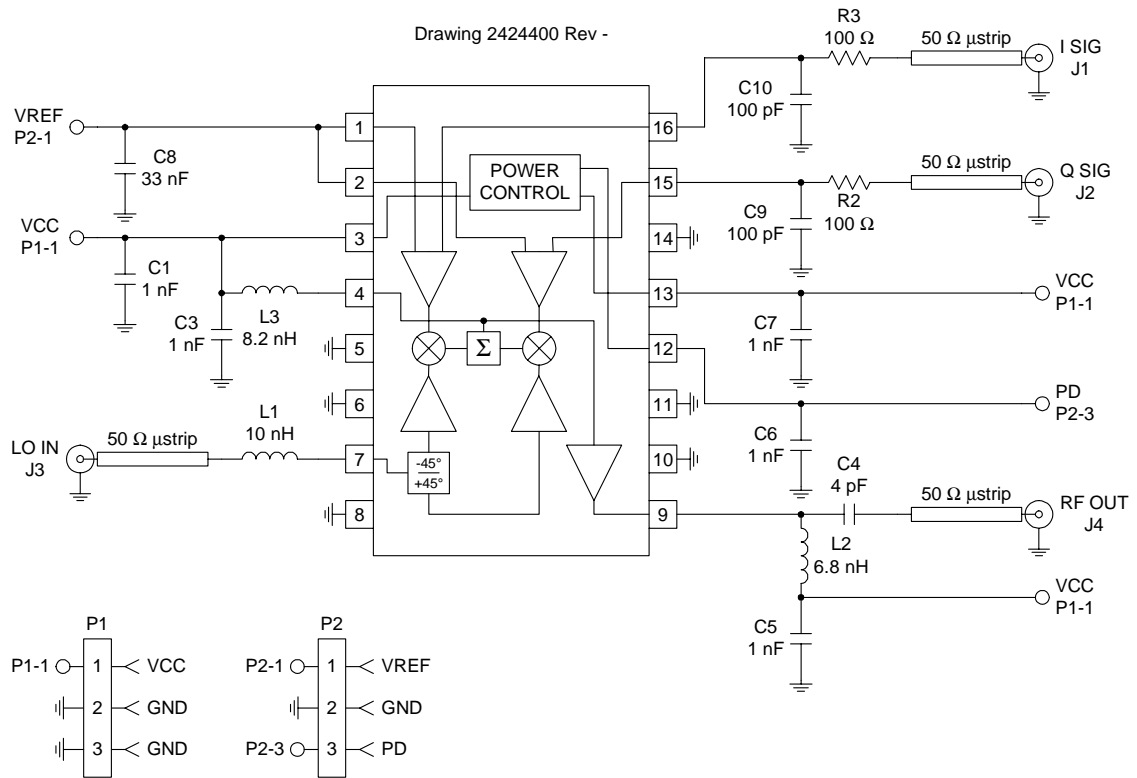

RF2424

Evaluation Board Layout 2" x 2"

