

Typical Applications

- CDMA/TDMA/DCS1900 PCS Systems
- PHS 1500/WLAN 2400 Systems
- General Purpose Downconverter
- Micro-Cell PCS Base Stations
- Portable Battery-Powered Equipment

Product Description

The RF2486 is a monolithic integrated receiver front-end for PCS, PHS, and WLAN applications. The IC contains all of the required components to implement the RF functions of the receiver front-end except for the passive filtering and LO generation. It contains an LNA (low-noise amplifiers), a double-balanced Gilbert cell mixer, a balanced IF output, an LO isolation buffer amplifier, and an LO output buffer amplifier for providing the buffered LO signal as an output. The IC is designed to operate from a single 3.6V power supply.

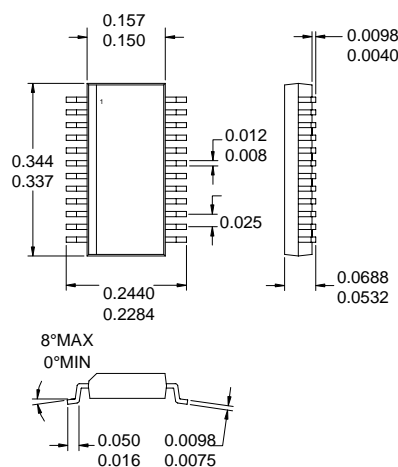

Optimum Technology Matching® Applied

- | | | |
|--|-----------------------------------|--------------------------------------|
| <input type="checkbox"/> Si BJT | <input type="checkbox"/> GaAs HBT | <input type="checkbox"/> GaAs MESFET |
| <input checked="" type="checkbox"/> Si Bi-CMOS | <input type="checkbox"/> SiGe HBT | <input type="checkbox"/> Si CMOS |

Package Style: SSOP-24

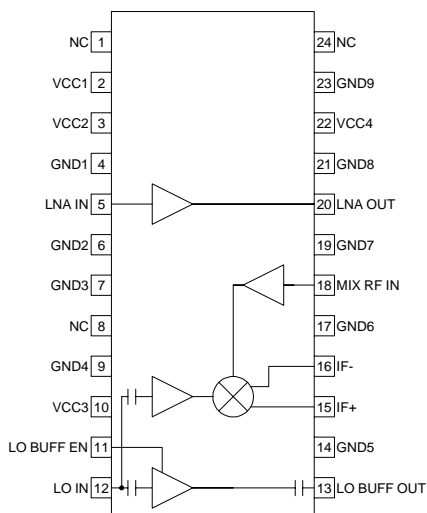

Functional Block Diagram

Features

- Complete Receiver Front-End
- High Dynamic Range
- Single 3.6V Power Supply
- External LNA IP3 Adjustment
- 1500MHz to 2500MHz Operation

Ordering Information

- | | |
|---------------|--|
| RF2486 | PCS Low Noise Amplifier/Mixer |
| RF2486 PCBA-L | Fully Assembled Evaluation Board 1.96GHz |
| RF2486 PCBA-H | Fully Assembled Evaluation Board 2.4GHz |

RF Micro Devices, Inc.
7628 Thorndike Road
Greensboro, NC 27409, USA

Tel (336) 664 1233
Fax (336) 664 0454
<http://www.rfmd.com>

RF2486

Absolute Maximum Ratings

Parameter	Rating	Unit
Supply Voltage	-0.5 to 5.5	V _{DC}
Input LO and RF Levels	+6	dBm
Ambient Operating Temperature	-40 to +85	°C
Storage Temperature	-40 to +150	°C



Caution! ESD sensitive device.

RF Micro Devices believes the furnished information is correct and accurate at the time of this printing. However, RF Micro Devices reserves the right to make changes to its products without notice. RF Micro Devices does not assume responsibility for the use of the described product(s).

Parameter	Specification			Unit	Condition
	Min.	Typ.	Max.		
Overall					T = 25°C, V _{CC} =3.6V, RF=1959MHz, LO=1749MHz @ +1 dBm
RF Frequency Range	1500		2500	MHz	
LO Frequency Range	1200		2500	MHz	
IF Frequency Range	DC		500	MHz	
Cascaded Performance					1 kΩ balanced load, 2.5 dB Image Filter Loss.
Cascade Conversion Gain	24	27	28	dB	
Cascade Input IP3	-17	-16		dBm	
Cascade Noise Figure		3.6		dB	Single Sideband
First Section (LNA)					The LNA section may be left unused. Power is not connected to pin 1. The performance is then as specified for the Second Section (Mixer).
Noise Figure		1.8		dB	
Input VSWR		1.5:1	2.0:1		Input is internally matched for optimum noise figure from a 50Ω source.
Input IP3		+4		dBm	IP3 may be increased 10 dB by connecting pin 22 to V _{CC} through the matching inductor. The LNA's current then increases by 10 mA. Other in-between IP3 versus I _{CC} trade-offs may be made. See pin description for pin 20.
		+8.5		dBm	R2=Open
Gain		13.5		dB	R2=Short
Reverse Isolation		23		dB	
Output VSWR		<1.5:1			
Second Section (Mixer)					With 1 kΩ balanced load.
Noise Figure		10		dB	Single Sideband
Input VSWR		1.5:1			
Input IP3		-5		dBm	
Conversion Gain		16		dB	
Output Impedance		1		kΩ	Balanced
LO Input					
LO Input Range	-3		+3	dBm	
LO Output Level	-7	-3	+1	dBm	Buffer On, +1 dBm input
		-22	-14	dBm	Buffer Off, +1 dBm input
LO to RF (Mix In) Rejection		30		dB	
LO to IF1, IF2 Rejection		20		dB	
LO Input VSWR		1.5:1			Single ended
Power Supply					
Voltage	2.7	3.6	5.0	V	
Current Consumption		7		mA	LNA only
		52		mA	LNA + Mixer, LO Buffer On
		48		mA	LNA + Mixer, LO Buffer Off

8

FRONT-ENDS

Pin	Function	Description	Interface Schematic
1	NC	No connection. This pin may be grounded (recommended) or left open.	
2	VCC1	Supply voltage for the mixer and RF buffer amplifier. External RF bypassing is required. The trace length between the pin and the bypass capacitor should be minimized. The ground side of the bypass capacitor should connect immediately to ground plane.	
3	VCC2	Supply voltage for the LNA. External RF bypassing is required. The trace length between the pin and the bypass capacitor should be minimized. The ground side of the bypass capacitor should connect immediately to ground plane.	
4	GND1	Ground connection for the LNA. For best performance, keep traces physically short and connect immediately to ground plane.	
5	LNA IN	RF input pin for the LNA. This pin is internally matched for minimum noise figure (NOT for minimum VSWR), given a 50Ω source impedance. This pin is not internally DC-blocked.	
6	GND2	Same as pin 4.	
7	GND3	Ground connection for the RF buffer amplifier. For best performance, keep traces physically short and connect immediately to ground plane.	
8	NC	No connection. This pin may be grounded (recommended) or left open.	
9	GND4	Same as pin 7.	
10	VCC3	Supply voltage for both LO buffer amplifiers. External RF bypassing is required. The trace length between the pin and the bypass capacitor should be minimized. The ground side of the bypass capacitor should connect immediately to ground plane.	
11	LO BUFF EN	Enable pin for the LO output buffer amplifier. This is a digitally controlled input. A logic "high" ($\geq 3.1V$) turns the buffer amplifier on, and the current consumption increases by 3mA (with -2dBm LO input). A logic "low" ($\leq 0.5V$) turns the buffer amplifier off.	
12	LO IN	Mixer LO input pin. This pin is internally DC-blocked and matched to 50Ω.	
13	LO BUFF OUT	Optional buffered LO output. This pin is internally DC-blocked and matched to 50Ω. The buffer amplifier is switched on or off by the voltage level at pin 11.	
14	GND5	Ground connection for both LO buffer amplifiers. For best performance, keep traces physically short and connect immediately to ground plane.	
15	IF+	Open-collector IF output pin. This is a balanced output. The output impedance is set by an internal 1000Ω resistor to pin 16. Thus the differential IF output impedance is 1000Ω. The resistor sets the operating impedance, but an external choke or matching inductor to V_{CC} must be supplied in order to bias this output. This inductor is typically incorporated in the matching network between the output and IF filter. Because this pin is biased to V_{CC} , a DC blocking capacitor must be used if the IF filter input has a DC path to ground.	
16	IF-	Same as pin 15, except complementary output.	See pin 15.
17	GND6	Ground connection for the mixer. For best performance, keep traces physically short and connect immediately to ground plane.	
18	MIX RF IN	Mixer RF input pin. This pin is internally DC-blocked and matched to 50Ω.	
19	GND7	Same as pin 17.	

RF2486

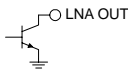
Pin	Function	Description	Interface Schematic
20	LNA OUT	LNA output pin. This is an open-collector output. This pin is typically connected to pin 22 through a bias/matching inductor. This inductor, in conjunction with a series blocking/matching capacitor, forms a matching network to the 50Ω image filter and provides bias (see application schematic). The LNA's IP3 may be increased 10dB by connecting pin 20 to V _{CC} through the inductor. The LNA's current then increases by 10mA. Other in-between IP3 versus I _{CC} trade-offs may be made by connecting resistance values between V _{CC} and the matching inductor. The two reference points for consideration are with 150Ω used, which is what connection to pin 22 achieves, the input IP3 is +5.5dBm and the LNA I _{CC} is 5mA. Using no resistance, the input IP3 is +15.5 dBm and the LNA I _{CC} is 15 mA. Desired operating points in between these values may be roughly interpolated.	
21	GND8	Same as pin 17.	
22	VCC4	Output supply voltage for the LNA output (pin 20). This pin is typically connected to pin 20 through a bias/matching inductor (see application schematic). External RF bypassing is required. The trace length between the pin and the bypass capacitor should be minimized. The ground side of the bypass capacitor should connect immediately to ground plane.	See pin 2.
23	GND9	Same as pin 17.	
24	NC	No connection. This pin may be grounded (recommended) or left open.	

Application Schematic 1.96GHz, 210MHz IF

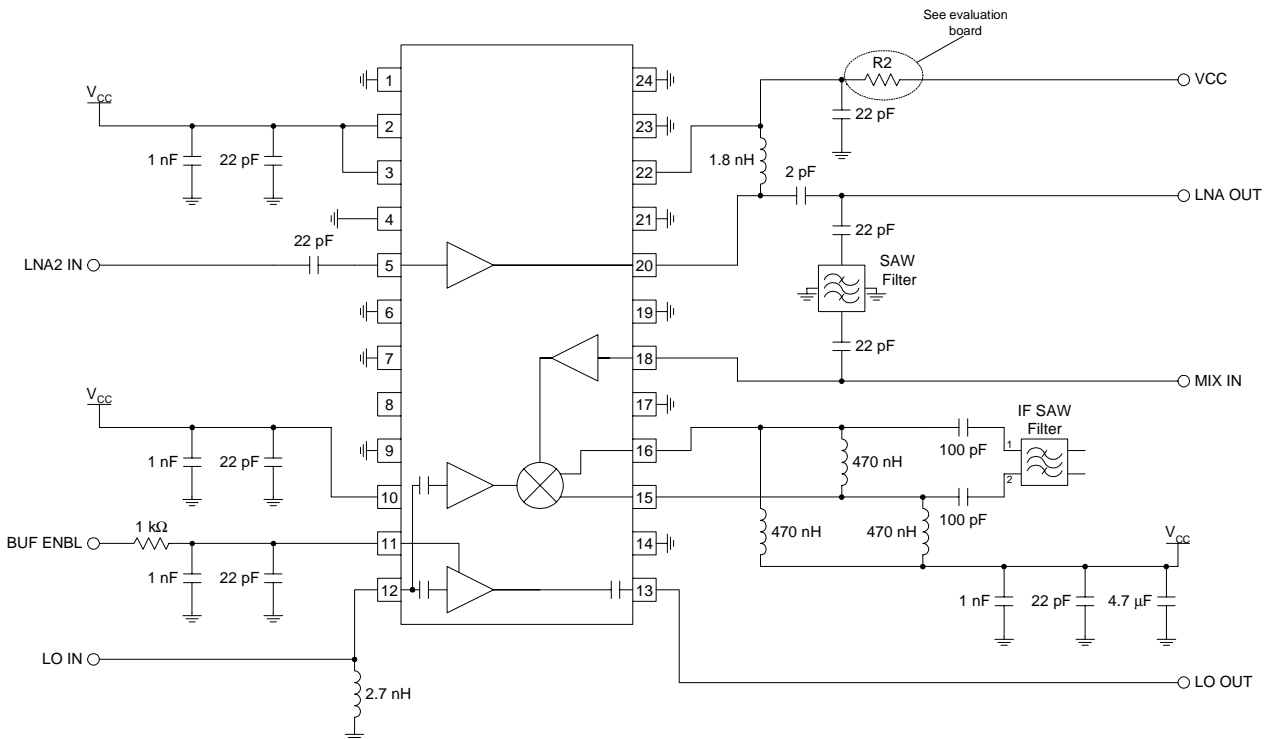

Evaluation Board Schematic 1.96GHz, 210MHz IF (Download [Bill of Materials](http://www.rfmd.com) from www.rfmd.com.)

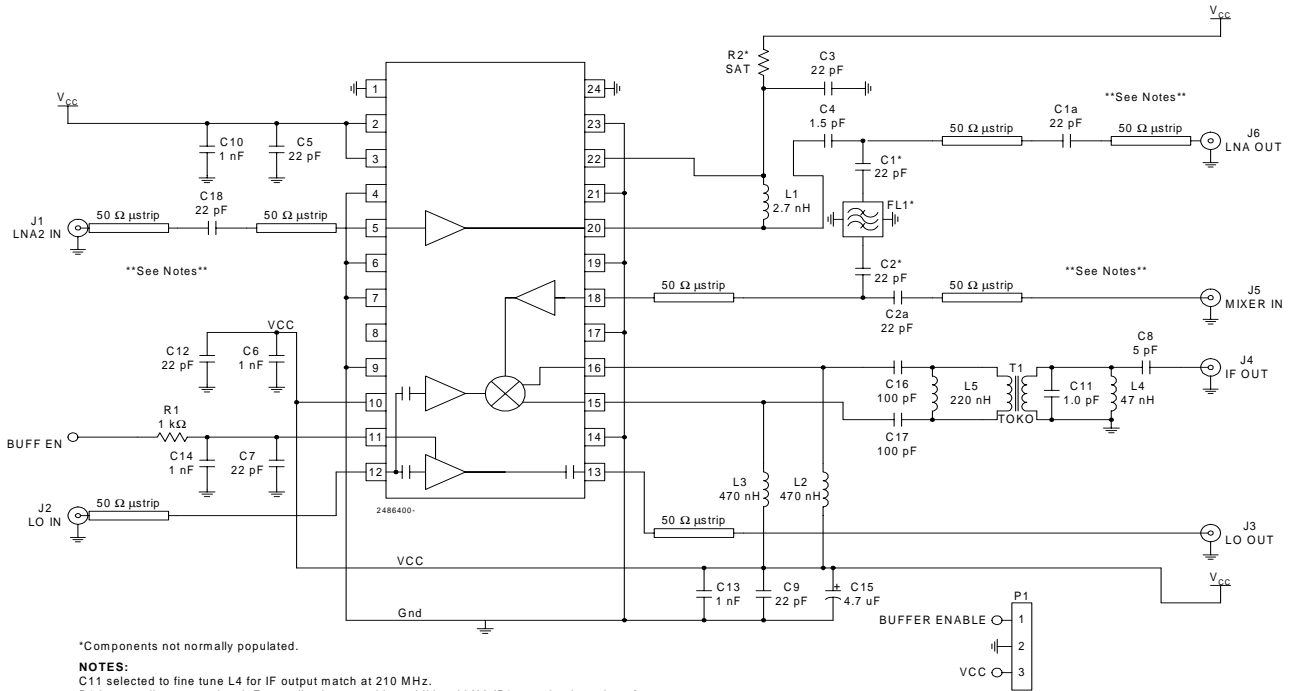

*Components not normally populated.

NOTES:

C11 selected to fine tune L4 for IF output match at 210 MHz.
R2 is normally not populated. For applications requiring additional LNA IP3, see the data sheet for recommended resistance values.
C1a and C2a are normally not populated. If C1a and C2a are populated, the LNA and mixer can be tested independently. In this case, C1 and C2 should be removed.
To use the part with onboard filter, do not populate C1a, and C2a.
Use C1 and C2 instead. This will allow cascaded operation only.

RF2486

Evaluation Board Schematic 2.4 GHz, 280MHz IF

(Download [Bill of Materials](http://www.rfmd.com) from www.rfmd.com.)

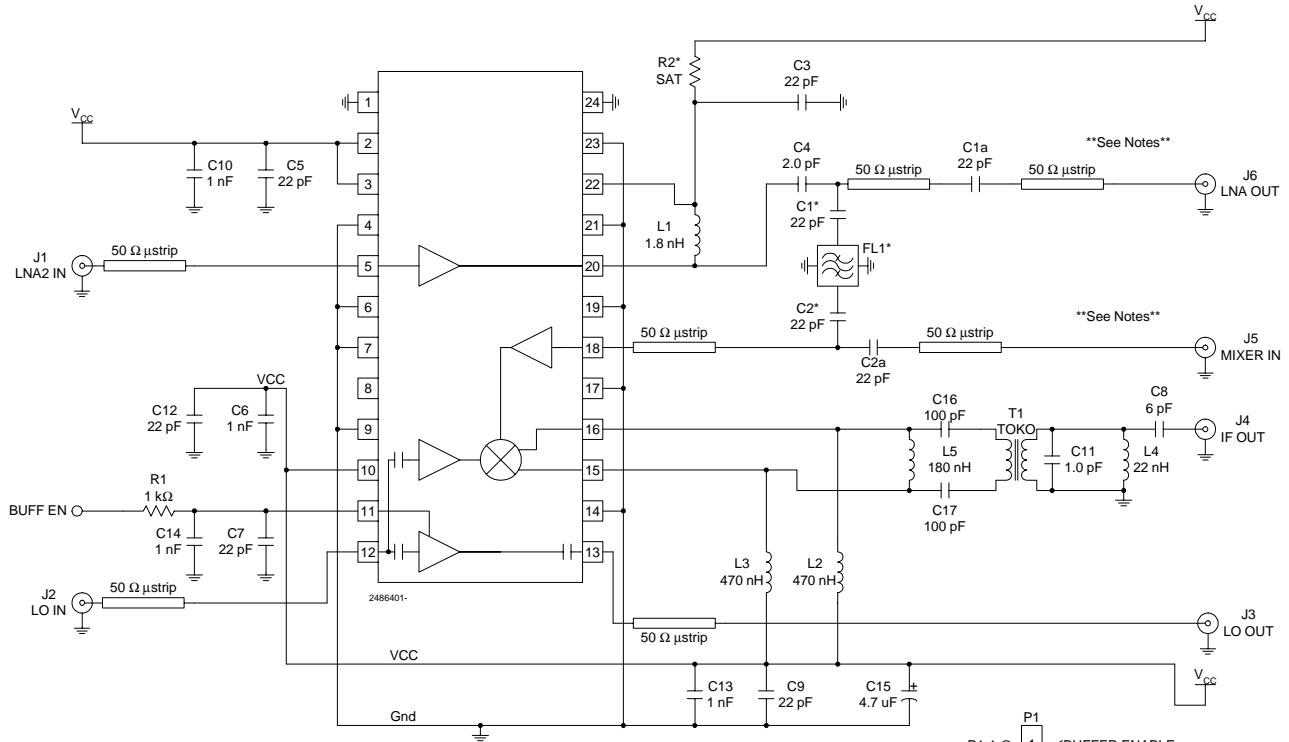

*Components not normally populated.

NOTES:

- C11 selected to Fine Tune L4 for IF Output Match at 280 MHz.
- R2 is normally not populated. For applications requiring additional LNA IP3, see the datasheet for recommended resistance values.
- C1a and C2a are normally not populated. If C1a and C2a are populated, the LNA and mixer can be tested independently.
- In this case, C1 and C2 should be removed.
- To use the part with onboard filter, do not populate C1a, and C2a.
- Use C1 and C2 instead. This will allow cascaded operation only.

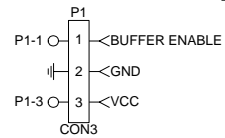

Evaluation Board Layout 1.96GHz
 Board Size 3.0" x 3.0"
 Board Thickness 0.075.6", Board Material FR-4, Multi-Layer
 (8 mils between Layers 1 and 2, 31 mils between Layers 2 and 3, 1 ounce copper all layers)

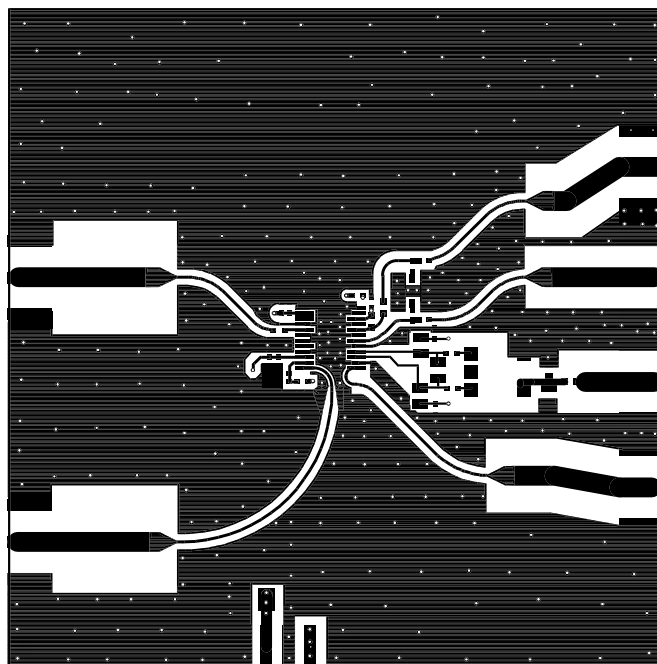
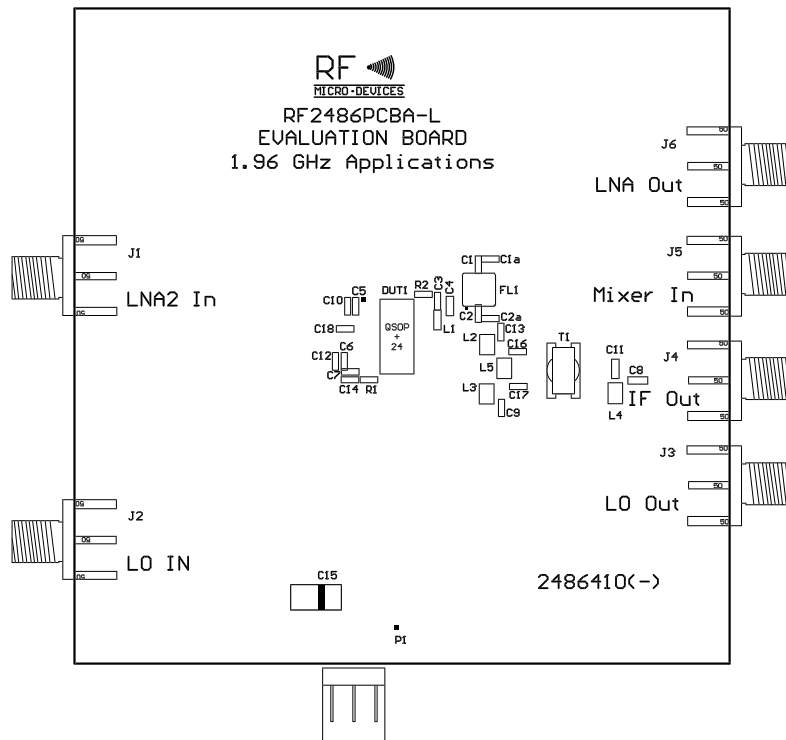

RF2486

Evaluation Board Layout 2.4 GHz Board Size 3.0" x 3.0"

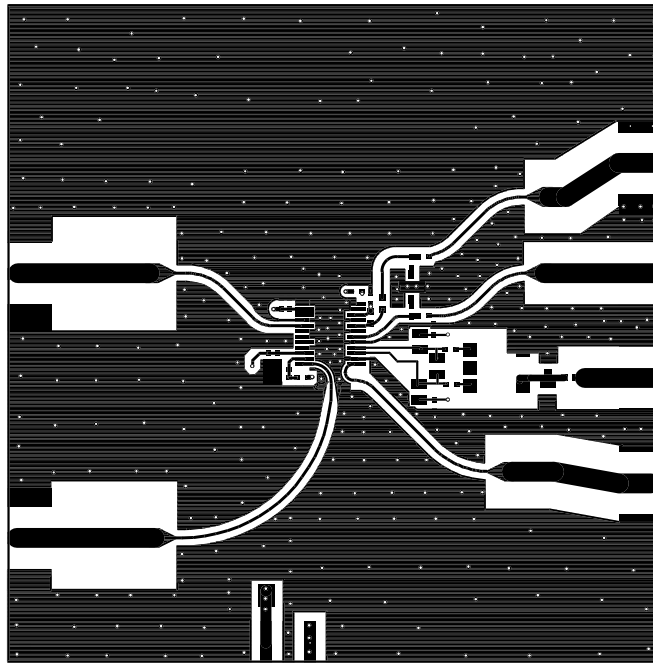
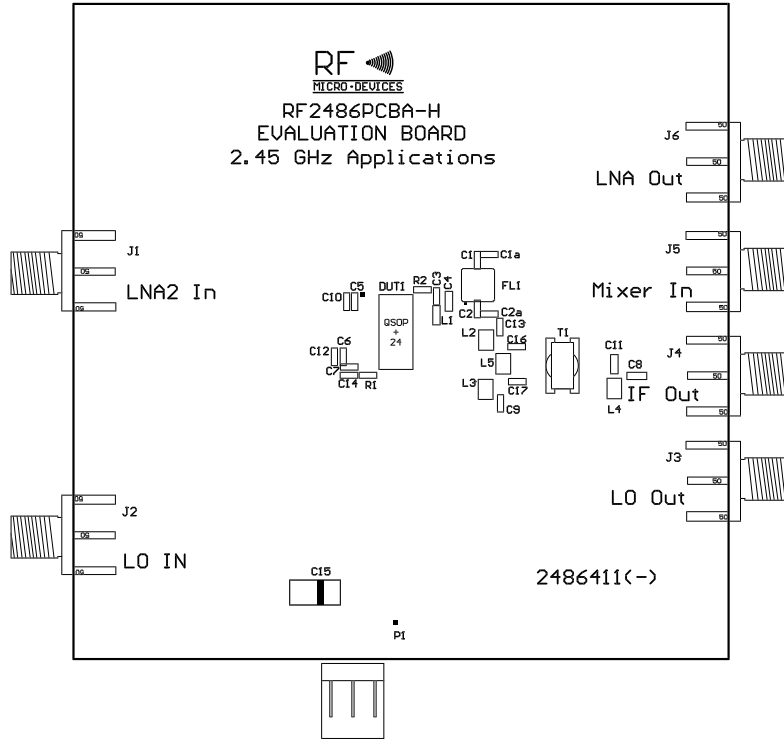

8

FRONT-ENDS