

Typical Applications

- Local Oscillator Source
- FM/FSK Transmitter
- Wireless Data Transmitters
- 433/868/915MHz ISM Band Systems
- Low-Cost Single Frequency LO Source
- Wireless Security Systems

Product Description

The RF2510 is a monolithic integrated circuit intended for use as a low-cost Frequency Synthesizer. The device is provided in a 16 pin SSOP package and is designed to provide a phased locked frequency source for use in local oscillator or transmitter applications. The chip can be used in FM or FSK applications in the U.S. 915MHz ISM band and European 433MHz and 868MHz ISM band. The integrated VCO, dual modulus/dual divide (128/129 or 64/65) pre-scaler, and reference oscillator require only the addition of an external crystal to provide a complete phase-locked oscillator.

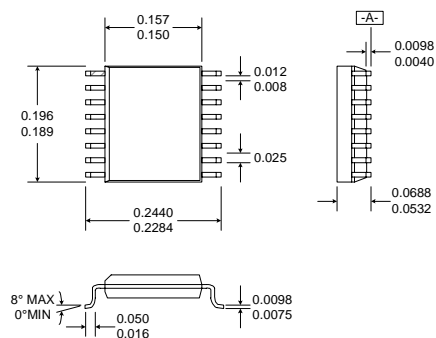

- NOTES:
1. Shaded lead is Pin 1.
  2. All dimensions are excluding mold flash.
  3. Lead coplanarity - 0.005 with respect to datum 'A'.

Optimum Technology Matching® Applied

- |  |                                   |                                      |
|--|-----------------------------------|--------------------------------------|
| <input checked="" type="checkbox"/> Si BJT | <input type="checkbox"/> GaAs HBT | <input type="checkbox"/> GaAs MESFET |
| <input type="checkbox"/> Si Bi-CMOS        | <input type="checkbox"/> SiGe HBT | <input type="checkbox"/> Si CMOS     |

Package Style: SSOP-16

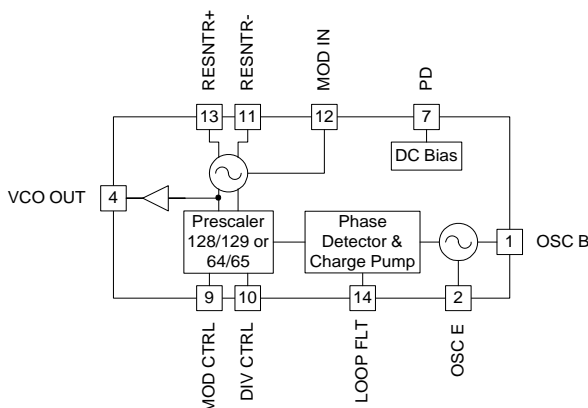

Functional Block Diagram

Features

- Fully Integrated PLL Circuit
- Integrated VCO and Reference Oscillator
- 2.4V to 5.0V Supply Voltage
- Low Current and Power Down Capability
- 300MHz to 1000MHz Frequency Range
- Narrowband and Wideband FM

Ordering Information

- |               |   |
|---------------|---|
| RF2510        | VHF/UHF Transmitter                     |
| RF2510 PCBA-L | Fully Assembled Evaluation Board 433MHz |
| RF2510 PCBA-M | Fully Assembled Evaluation Board 868MHz |
| RF2510 PCBA-H | Fully Assembled Evaluation Board 915MHz |

RF Micro Devices, Inc.  
7625 Thorndike Road  
Greensboro, NC 27409, USA

Tel (336) 664 1233  
Fax (336) 664 0454  
<http://www.rfmd.com>

### Absolute Maximum Ratings

Parameter	Rating	Unit
Supply Voltage	-0.5 to +5.5	V <sub>DC</sub>
Power Down Voltage (V <sub>PD</sub> )	-0.5 to V <sub>CC</sub>	V
Operating Ambient Temperature	-40 to +85	°C
Storage Temperature	-40 to +150	°C



**Caution!** ESD sensitive device.

RF Micro Devices believes the furnished information is correct and accurate at the time of this printing. However, RF Micro Devices reserves the right to make changes to its products without notice. RF Micro Devices does not assume responsibility for the use of the described product(s).

Parameter	Specification			Unit	Condition
	Min.	Typ.	Max.		
<b>Overall</b>					T=25 °C, V <sub>CC</sub> =3.6V, Freq=915MHz
Frequency Range		300 to 1000		MHz	
Modulation		FM/FSK			
Modulation Frequency			2	MHz	Modulation frequency and deviation dependent on VCO components L2, L3, C11, and D1.
Maximum FM Deviation	200			kHz	
Output Power		-2.5		dBm	50Ω load, no output attenuator
Output Load VSWR			2:1		To maintain PLL lock
Add 1 dB pad			3:1		
Add 2 dB pad			6:1		
Add 3 dB pad			20:1		
<b>PLL and Prescaler</b>					
Prescaler Divide Ratio		64/65 or 128/129			Dependent upon external components, Freq=915MHz, 868Mhz
VCO Gain, K <sub>VCO</sub>		70		MHz/V	
		25		MHz/V	Freq=433MHz
PLL Phase Noise		-72		dBc/Hz	10kHz Offset, 5kHz loop bandwidth
		-98		dBc/Hz	100kHz Offset, 5kHz loop bandwidth
Harmonics		-15		dBc	Without filtering.
Reference Frequency			17	MHz	
Crystal Frequency Spurs		-62		dBc	5kHz PLL loop bandwidth
Max Crystal R <sub>S</sub>		50	100	Ω	
Charge Pump Current	-40		+40	μA	
<b>Power Down Control</b>					
Power Down "ON"	2.0			V	Voltage supplied to the input; device is "ON"
Power Down "OFF"			1.0	V	Voltage supplied to the input; device is "OFF"
Control Input Impedance	25k			Ω	
Turn On Time		2	4	ms	Crystal start-up, 7.15MHz crystal. PLL lock time additional 4/(loop bandwidth) sec.
<b>Power Supply</b>					
Voltage	2.4	3.6	5	V	Specifications
	2.2			V	Operating limits over temp
	7	10.5	13.5	mA	T < +40°C
Current Consumption			1	μA	Sleep mode

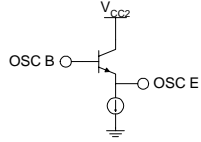
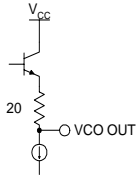
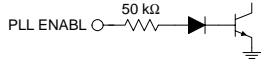
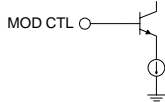
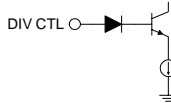
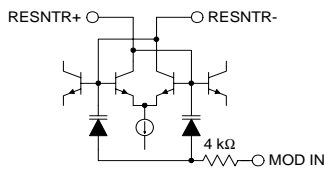
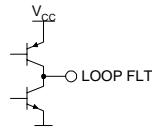
Pin	Function	Description	Interface Schematic
1	OSC B	This pin is connected directly to the reference oscillator transistor base. The intended reference oscillator configuration is a modified Colpitts. An appropriate capacitor as chosen by the customer should be connected between pin 1 and pin 2.	
2	OSC E	This pin is connected directly to the emitter of the reference oscillator transistor. An appropriate capacitor as chosen by the customer should be connected from this pin to ground.	See pin 1.
3	GND1	Ground connection for the VCO OUT buffer amp.	
4	VCO OUT	Buffered output of the VCO	
5	VCC	This pin is used to supply DC bias to the entire IC. ARF Bypass capacitor should be connected directly to ground.	
6	GND	Ground connection.	
7	PD	Power Down control for all circuitry. When this pin is a logic "low" all circuits are turned off.	
8	NC	Not internally connected.	
9	MOD CTRL	This pin is used to select the prescaler modulus. A logic "high" selects 64 or 128 for the prescaler divisor. A logic "low" selects 65 or 129 for the prescaler divisor.	
10	DIV CTRL	This pin is used to select the desired prescaler divisor. A logic "high" selects the 64/65 divisor. A logic low selects the 128/129 divisor.	
11	RESNTR-	The RESNTR pins are used to supply DC voltage to the VCO, as well as to tune the center frequency of the VCO. Equal value inductors should be connected to this pin and pin 13.	
12	MOD IN	FM analog or digital modulation can be imparted to the VCO through this pin. The VCO varies in accordance to the voltage level presented to this pin. To set the deviation to a desired level, a voltage divider referenced to Vcc is recommended. Because the modulation varactors are part of the resonator tank, the deviation is slightly dependent upon the components used in the external tank.	See pin 11.
13	RESNTR+	See pin 11.	See pin 11.
14	LOOP FLT	Output of the charge pump. An RC network from this pin to ground is used to establish the PLL bandwidth.	

Pin	Function	Description	Interface Schematic
15	VREF P	Bias voltage reference pin for bypassing the prescaler and phase detector. The bypass capacitor should be of appropriate size to provide filtering of the reference crystal frequency and be connected directly to this pin.	
16	NC	Not internally connected.	
	ESD	This diode structure is used to provide electrostatic discharge protection to 3kV using the human body model. the following pins are protected: 1, 2, 3, 5, 6, 7, 9, 10, 14, and 15.	<p>The schematic shows a vertical line with a circle labeled 'PIN' in the middle. Above the circle is a diode symbol pointing upwards towards a label 'V<sub>CC</sub>'. Below the circle is another diode symbol pointing downwards towards a ground symbol.</p>

Pin Out

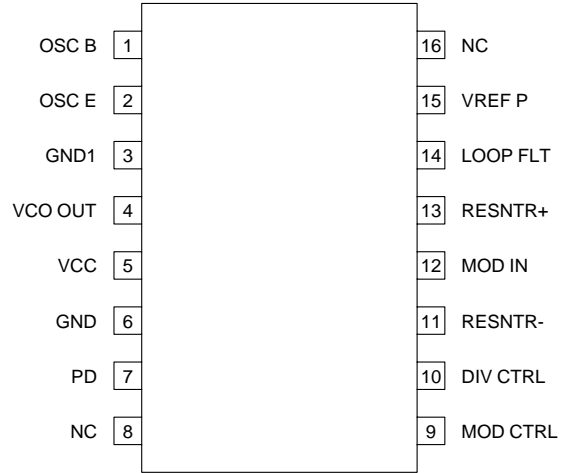

## Application Schematic (915MHz)

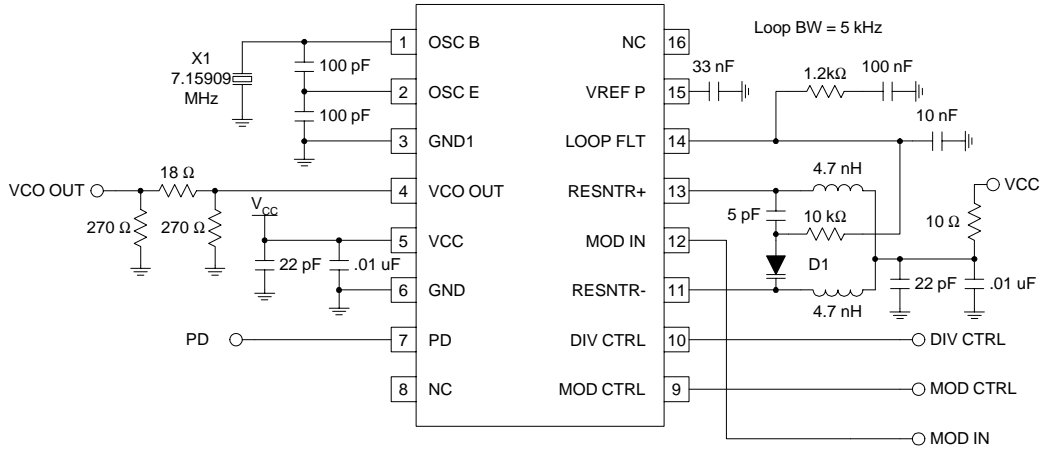

D1 : SMV1233-011

## Application Schematic (915MHz)

### RF2510 Audio Transmitter

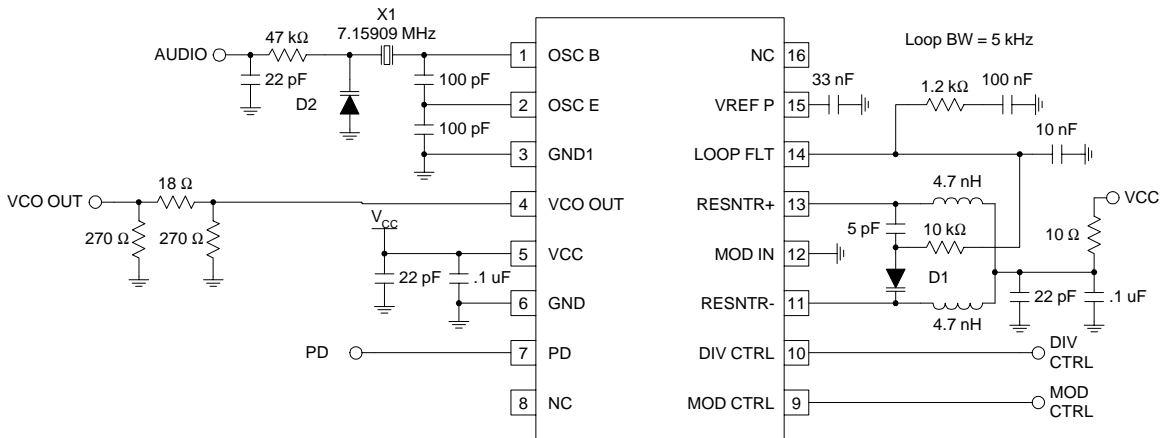

D1, D2 : SMV1233-011

### Evaluation Board Schematic 433 MHz

(Download [Bill of Materials](http://www.rfmd.com) from [www.rfmd.com](http://www.rfmd.com).)

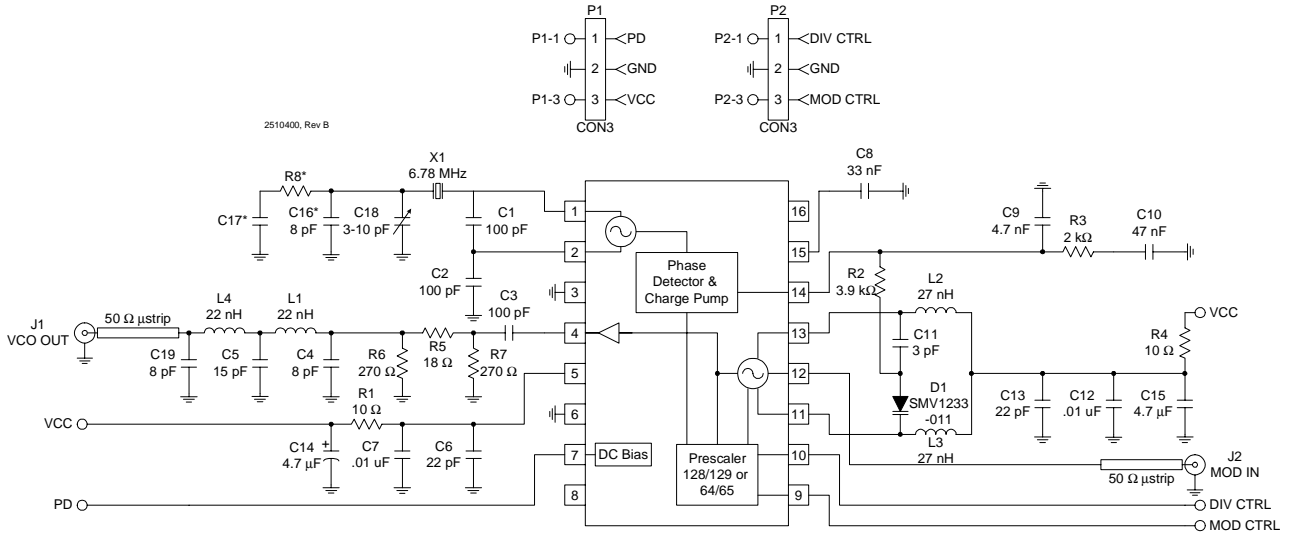

Evaluation Board Schematic  
868 MHz

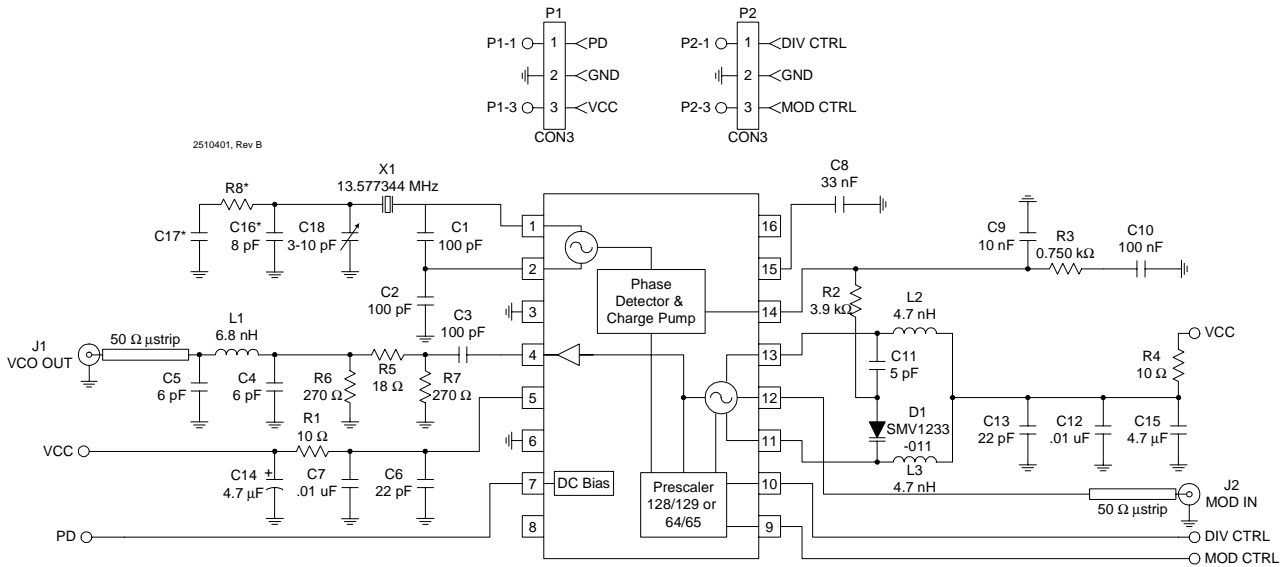

Evaluation Board Schematic  
915 MHz

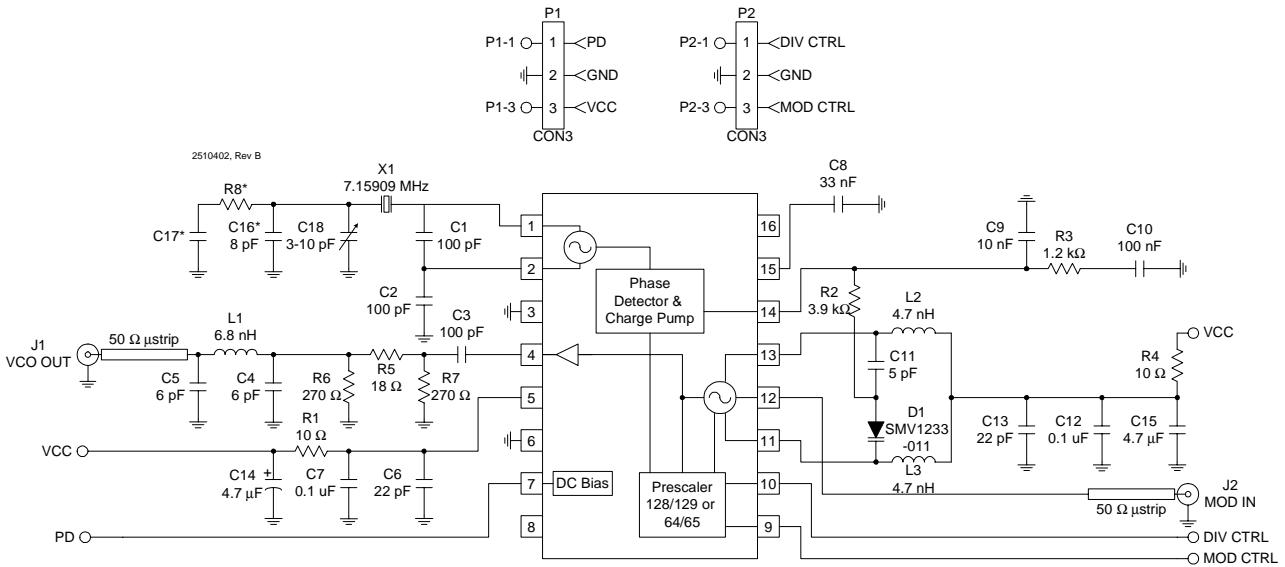



Evaluation Board Layout 433MHz  
Board Size 1.500" x 1.000"  
Board Thickness 0.031", Board Material FR4

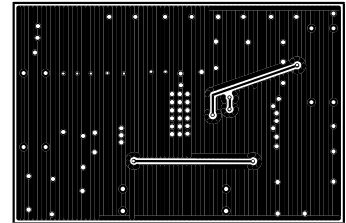
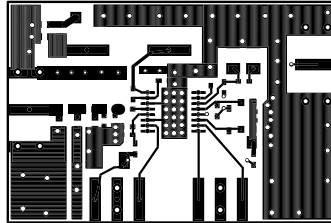
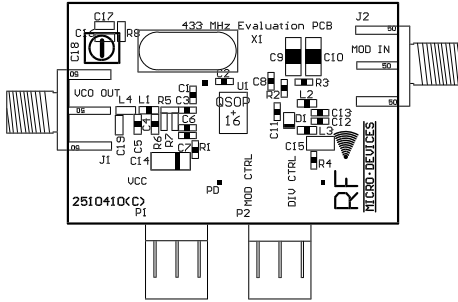

Evaluation Board Layout 868MHz  
Board Size 1.500" x 1.000"

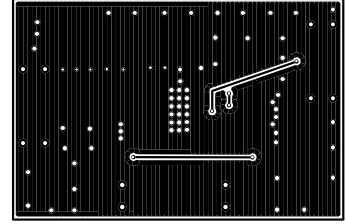
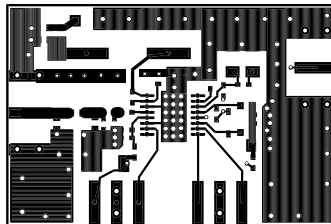
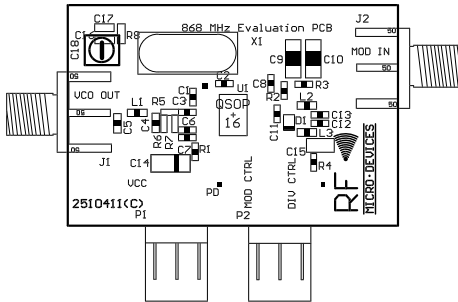

Evaluation Board Layout 915MHz  
Board Size 1.500" x 1.000"

