

Typical Applications

- 3V CDMA US-PCS Handsets
- 3V CDMA2000/1X PCS Handsets
- Spread-Spectrum Systems
- Designed for Compatibility with Qualcomm Chipsets

Product Description

The RF3100-3 is a high-power, high-efficiency linear amplifier IC targeting 3V hand-held systems. The device is manufactured on an advanced Gallium Arsenide Heterojunction Bipolar Transistor (HBT) process, and has been designed for use as the final RF amplifier in dual-mode 3V CDMA hand-held digital cellular equipment, spread-spectrum systems, and other applications in the 1850MHz to 1910MHz band. The RF3100-3 has a digital control line for low power application to reduce the current drain. The device is self-contained with 50Ω input and output that is matched to obtain optimum power, efficiency, and linearity characteristics. The module is an ultra-small 6mmx6mm land grid array with backside ground.

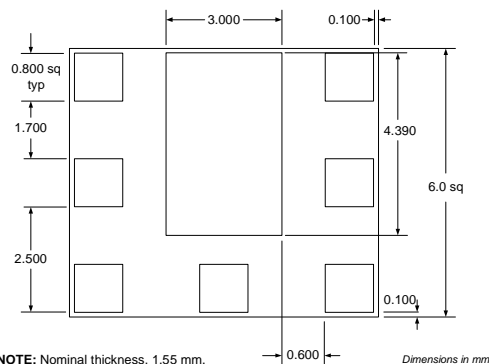

Optimum Technology Matching® Applied

- Si BJT       GaAs HBT       GaAs MESFET  
 Si Bi-CMOS       SiGe HBT       Si CMOS

Package Style: LGM (6mmx6mm)

Features

- Input/Output Internally Matched @ 50Ω
- Single 3V Supply
- 28dBm Linear Output Power
- -141 dBm/Hz Noise Power
- 35% Linear Efficiency
- 45mA Idle Current (Low Power Mode)

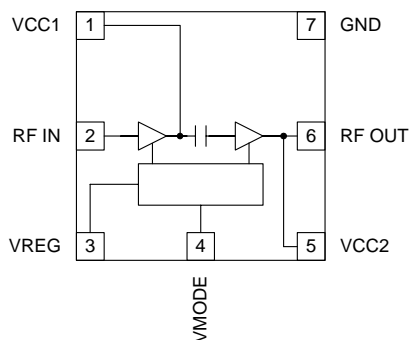

Functional Block Diagram

Ordering Information

RF3100-3      3V 1900MHz Linear Amplifier Module  
 RF3100-3 PCBA      Fully Assembled Evaluation Board

RF Micro Devices, Inc.  
 7628 Thorndike Road  
 Greensboro, NC 27409, USA

Tel (336) 664 1233  
 Fax (336) 664 0454  
<http://www.rfmd.com>

# RF3100-3

## Absolute Maximum Ratings

Parameter	Rating	Unit
Supply Voltage (RF off)	+8.0	V <sub>DC</sub>
Supply Voltage (P <sub>OUT</sub> ≤28dBm)	+5.2	V <sub>DC</sub>
Control Voltage (V <sub>REG</sub> )	+4.2	V <sub>DC</sub>
Mode Voltage (V <sub>MODE</sub> )	+3.5	V <sub>DC</sub>
Input RF Power	+10	dBm
Operating Case Temperature	-30 to +110	°C
Storage Temperature	-30 to +150	°C



**Caution!** ESD sensitive device.

RF Micro Devices believes the furnished information is correct and accurate at the time of this printing. However, RF Micro Devices reserves the right to make changes to its products without notice. RF Micro Devices does not assume responsibility for the use of the described product(s).

2

POWER AMPLIFIERS

Parameter	Specification			Unit	Condition
	Min.	Typ.	Max.		
<b>High Power State</b> (V <sub>MODE</sub> Low)					Typical Performance at V <sub>CC</sub> =3.2V, V <sub>REG</sub> =2.85V, T <sub>AMB</sub> =25°C, Frequency=1850MHz to 1910MHz (unless otherwise specified)
Frequency Range	1850		1910	MHz	
Linear Gain	24	26.5		dB	
Second Harmonic		-43		dBc	
Third Harmonic		-56		dBc	
Maximum Linear Output Power (CDMA Modulation)	28			dBm	
Total Linear Efficiency		35		%	P <sub>OUT</sub> =28dBm
Adjacent Channel Power Rejection		-48	-45	dBc	ACPR @ 1.25MHz, V <sub>CC</sub> =3.4V, P <sub>OUT</sub> =28dBm
		-62	-58	dBc	ACPR @ 2.25MHz, V <sub>CC</sub> =3.4V, P <sub>OUT</sub> =28dBm
Input VSWR		<2.5:1			
Output VSWR			10:1		No damage.
			6:1		No oscillations. >-70dBc
Noise Power		-141		dBm/Hz	At 80MHz offset.
<b>Low Power State</b> (V <sub>MODE</sub> High)					Typical Performance at V <sub>CC</sub> =3.2V, V <sub>REG</sub> =2.85V, T <sub>AMB</sub> =25°C, Frequency=1850MHz to 1910MHz (unless otherwise specified)
Frequency Range	1850		1910	MHz	
Linear Gain	14	19		dB	
Second Harmonic		-43		dBc	
Third Harmonic		-56		dBc	
Maximum Linear Output Power (CDMA Modulation)	16			dBm	
Adjacent Channel Power Rejection		-52	-46	dBc	ACPR @ 1.25MHz
		-66	-59	dBc	ACPR @ 2.25MHz
Input VSWR		<2.5:1			
Output VSWR			10:1		No damage.
			6:1		No oscillations. >-70dBc

# RF3100-3

Parameter	Specification			Unit	Condition
	Min.	Typ.	Max.		
<b>DC Supply</b>					$T_{AMB}=25^{\circ}C$
Supply Voltage	3.2	3.7	4.2	V	
Quiescent Current		170	240	mA	$V_{MODE}=Low, V_{REG}=2.85V$
		50	80	mA	$V_{MODE}=High, V_{REG}=2.85V$
$V_{REG}$ Current		6	10	mA	
$V_{MODE}$ Current			1.5	mA	
Turn On/Off Time			6	$\mu s$	
Total Current (Power Down)		5	10	$\mu A$	$V_{REG}=Low, V_{MODE}=Low$
$V_{REG}$ "Low" Voltage	0		0.5	V	
$V_{REG}$ "High" Voltage	2.8	2.85	2.9	V	
$V_{MODE}$ "Low" Voltage	0		0.5	V	
$V_{MODE}$ "High" Voltage	2.0		3.0	V	

# RF3100-3

2

POWER AMPLIFIERS

Pin	Function	Description	Interface Schematic
1	VCC1	First stage collector supply. A low frequency decoupling capacitor (e.g., 1 $\mu$ F) is required.	
2	RF IN	RF input internally matched to 50 $\Omega$ . This input is internally AC-coupled.	
3	VREG	Regulated voltage supply for amplifier bias. In Power Down mode, both V <sub>REG</sub> and V <sub>MODE</sub> need to be LOW (<0.5V).	
4	VMODE	For nominal operation (High Power Mode), V <sub>MODE</sub> is set LOW. When set HIGH, devices are turned off to improve efficiency.	
5	VCC2	Output stage collector supply. A low frequency decoupling capacitor (e.g., 1 $\mu$ F) is required.	
6	RF OUT	RF output internally matched to 50 $\Omega$ . This output is internally AC-coupled.	
7	GND	Ground connection. Connect to package base ground. For best performance, keep traces physically short and connect immediately to ground plane.	
Pkg Base	GND	Ground connection. The backside of the package should be soldered to a top side ground pad which is connected to the ground plane with multiple vias. The pad should have a short thermal path to the ground plane.	

## Evaluation Board Schematic (Download [Bill of Materials](http://www.rfmd.com) from [www.rfmd.com](http://www.rfmd.com).)

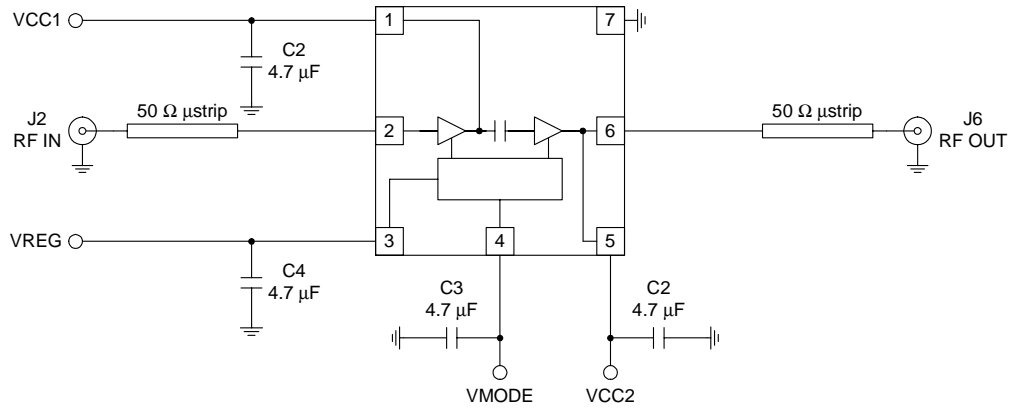

# RF3100-3

## Evaluation Board Layout Board Size 1.5" x 1.5"

Board Thickness 0.032", Board Material FR-4, Multi-Layer, Ground Plane at 0.014"

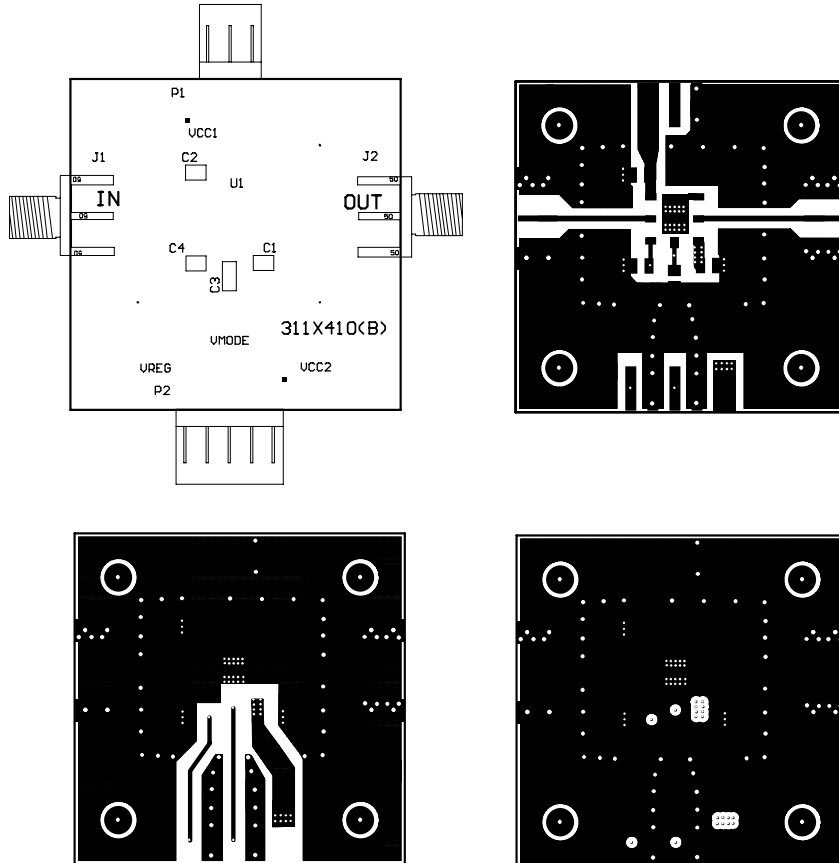

2

POWER AMPLIFIERS